

# BIPOLAR ANALOG INTEGRATED CIRCUIT

## $\mu$ PC1277H

### 4.2 W DUAL AUDIO POWER AMPLIFIER

#### DESCRIPTION

The  $\mu$ PC1277H is a dual audio power amplifier designed for a stereo radio cassette and in a 12-pin power single in line plastic package.

The  $\mu$ PC1277H has two audio power amplifiers and each of the two provides 4.2 W output power at 12 V/4 ohms.

#### FEATURES

- High output power.
 

4.2 W/ch (TYP.)	$V_{CC} = 12\text{ V}, R_L = 4\text{ ohms}$
5 W/ch (TYP.)	$V_{CC} = 12\text{ V}, R_L = 3\text{ ohms}$
2.2 W/ch (TYP.)	$V_{CC} = 9\text{ V}, R_L = 4\text{ ohms}$
3 W/ch (TYP.)	$V_{CC} = 9\text{ V}, R_L = 3\text{ ohms}$
- Wide operating voltage range.  $V_{CC} = 5\text{ to }16\text{ V}$
- No shock noise at power supply switch on and off.
- Soft clipping wave form.
- High ripple rejection ratio. R.R.R. = 50 dB (TYP.)
- Few external components. 12 parts
- Thermal shut'down circuit is built in.
- A 12-pin power SIP can easily be mounted on PCB and a external heat sink can easily be attached.

#### BLOCK DIAGRAM

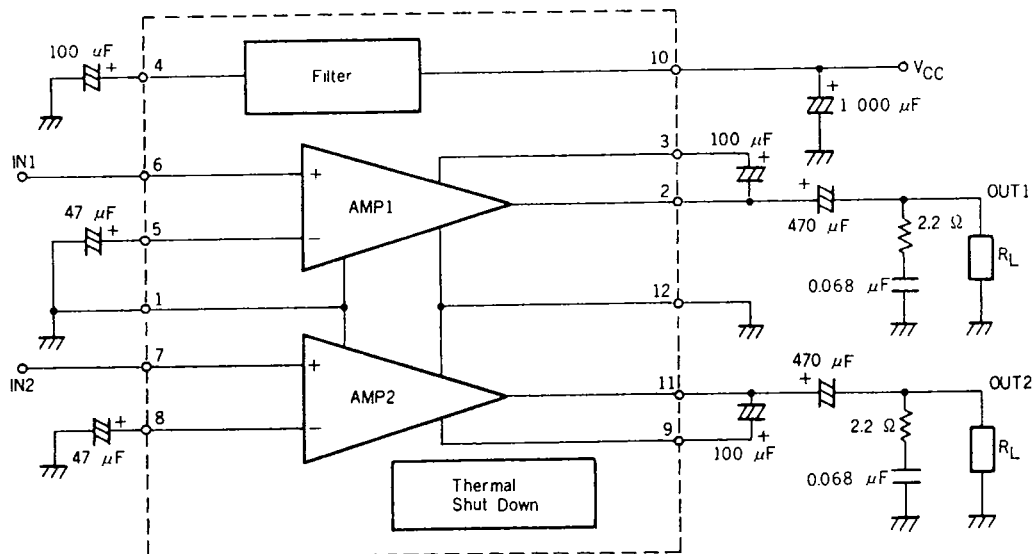

**μPC1277H**

6427525 N E C ELECTRONICS INC

72C 08667 D T-74-05-01

**PACKAGE DIMENSIONS** in millimeters (inches)

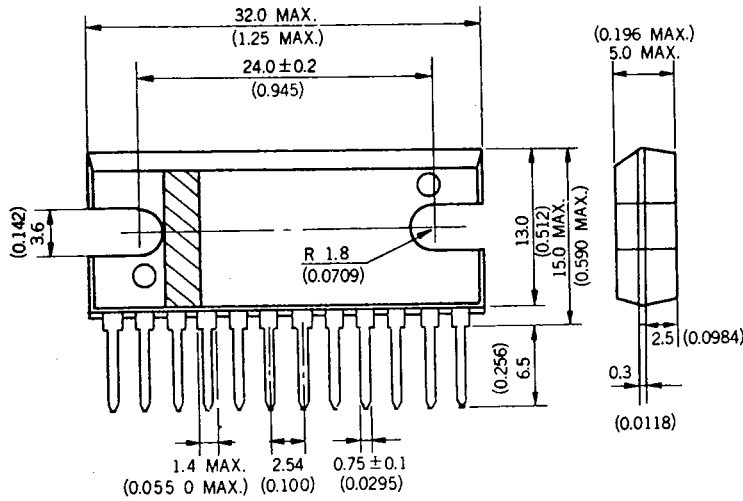

**CONNECTION DIAGRAM**

Pin No.	Connection
1	GND (Input)
2	Output 1
3	Boot Strap 1
4	Filter
5	NFB 1
6	Input 1
7	Input 2
8	NFB 2
9	Boot Strap 2
10	V <sub>CC</sub>
11	Output 2
12	GND (Output)

**ABSOLUTE MAXIMUM RATINGS** (T<sub>a</sub> = 25 °C)

Supply Voltage (No Signal)	V <sub>CC1</sub>	20	V
Supply Voltage (Operating)	V <sub>CC2</sub>	16	V
Allowable Power Dissipation	P <sub>D</sub>	13*	W
Operating Temperature	T <sub>opt</sub>	-20 to +75	°C
Storage Temperature	T <sub>stg</sub>	-40 to +150	°C

\* 100 x 100 x 2 mm<sup>3</sup> Al heat sink

**RECOMMENDED OPERATING CONDITIONS** (T<sub>a</sub> = 25 °C)

Supply Voltage	V <sub>CC</sub>	5 to 12 to 16	V
Load Impedance	R <sub>L</sub>	3 to 4 to 8	ohms

**ELECTRICAL CHARACTERISTICS**

(V<sub>CC</sub> = 12 V, R<sub>L</sub> = 4 ohm, f = 1 kHz, T<sub>a</sub> = 25 °C,  
100 x 100 x 2 mm Al Panel Heat Sink)

CHARACTERISTIC	SYMBOL	MIN.	TYP.	MAX.	UNIT	TEST CONDITION
Circuit Current	I <sub>CC</sub>	20	45	90	mA	No Signal
Voltage Gain	A <sub>v</sub>	42	45	48	dB	P <sub>O</sub> = 1 W
Output Power	P <sub>O1</sub>	1.8	2.2		W	T.H.D. = 10 % V <sub>CC</sub> = 9 V, R <sub>L</sub> = 4 ohm
	P <sub>O2</sub>	2.5	3		W	T.H.D. = 10 % V <sub>CC</sub> = 9 V, R <sub>L</sub> = 3 ohm
	P <sub>O3</sub>	3.2	4.2		W	T.H.D. = 10 % V <sub>CC</sub> = 12 V, R <sub>L</sub> = 4 ohm
	P <sub>O4</sub>	4	5		W	T.H.D. = 10 % V <sub>CC</sub> = 12 V, R <sub>L</sub> = 3 ohm
Total Harmonic Distortion	T.H.D.		0.2	1	%	P <sub>O</sub> = 1 W
Output Noise Voltage	NL		0.6	2	mVr.m.s.	R <sub>G</sub> = 10 kohm
Cross Talk	C.T.	45	55		dB	P <sub>O</sub> = 1 W other ch. R <sub>G</sub> = 10 kohm
Channel Balance	Ch. B.	-2	0	+2	dB	P <sub>O</sub> = 1 W
Ripple Rejection	R.R.	40	50		dB	R <sub>G</sub> = 0, f = 100 Hz v = 0.3 Vr.m.s.
Input Impedance	Z <sub>in</sub>	30	50		kohm	

TEST CIRCUIT

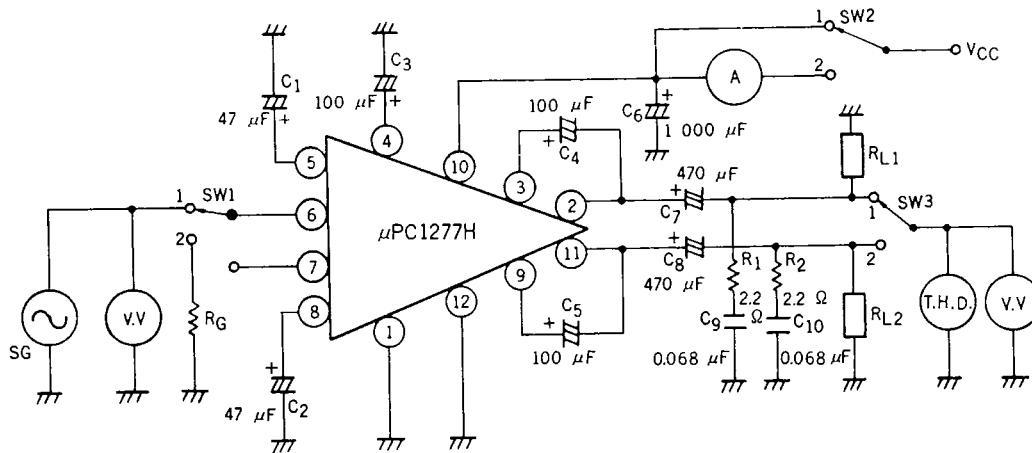

SWITCH POSITION  
(AMP 1 : TEST)

ITEM	SYMBOL	SW 1	SW 2	SW 3
Circuit Current	$I_{CC}$	2	2	1
Voltage Gain	$A_V$	1	1	1
Output Power	$P_O$	1	1	1
Total Harmonic Distortion	T.H.D.	1	1	1
Output Noise Voltage	NL	2	1	1

TYPICAL APPLICATION

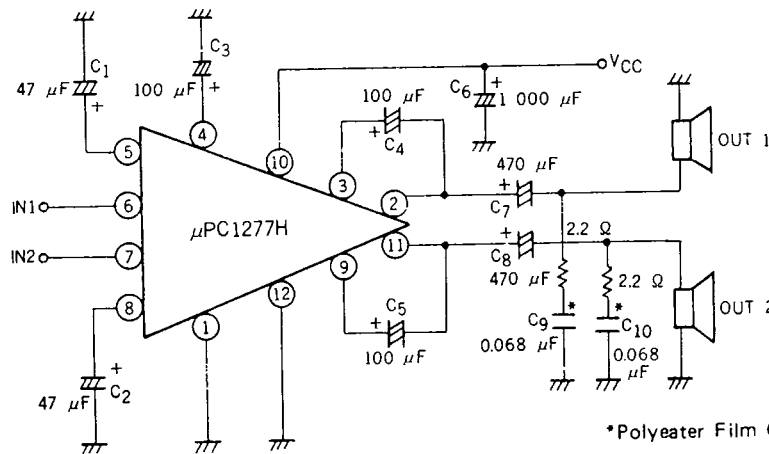

\*Polyester Film Capacitor

TYPICAL PCB  
(COPPER SIDE)

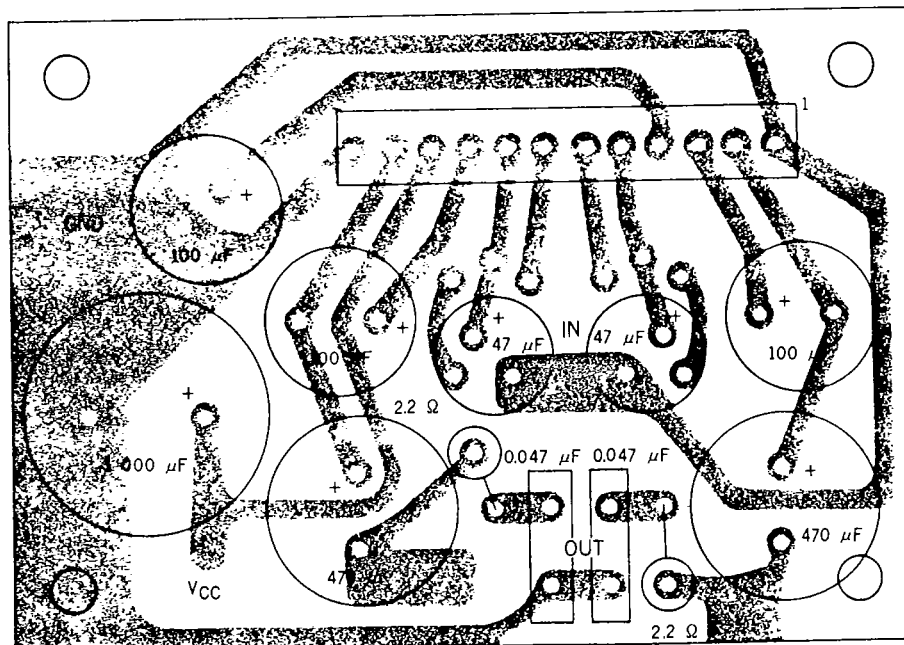

**μPC1277H**

6427525 N E C ELECTRONICS INC

72C 08669 DT-74-05-01

TYPICAL CHARACTERISTICS (Ta = 25 °C)

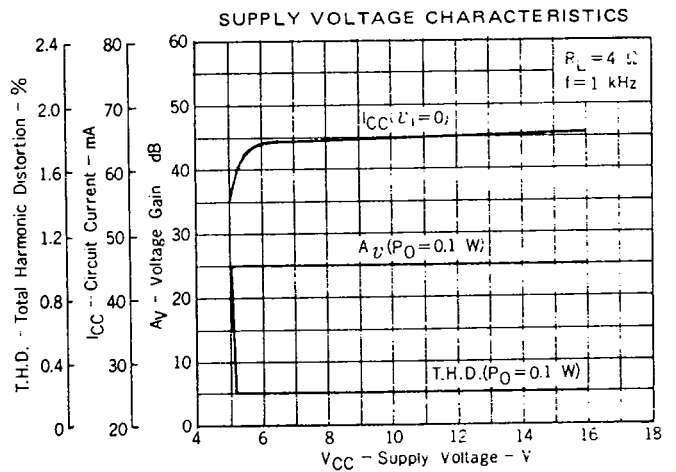
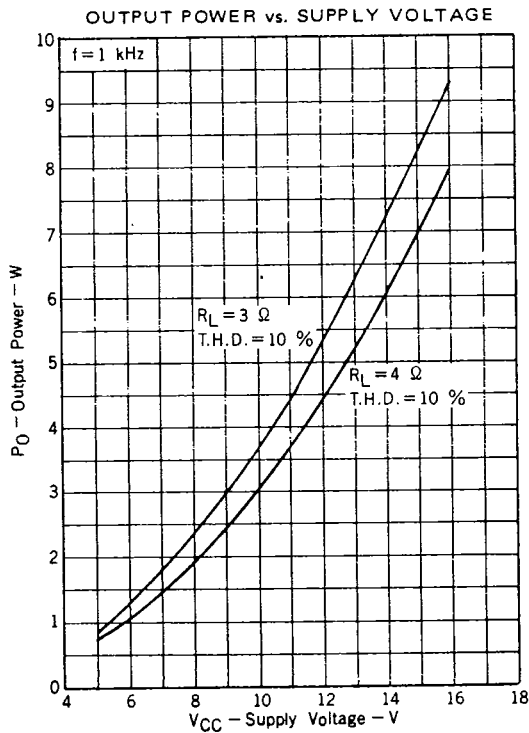
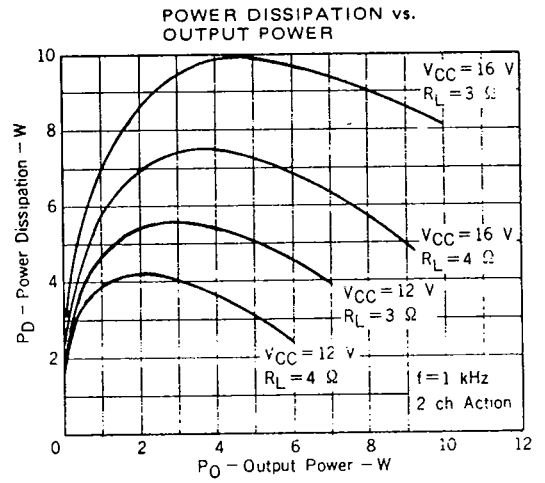
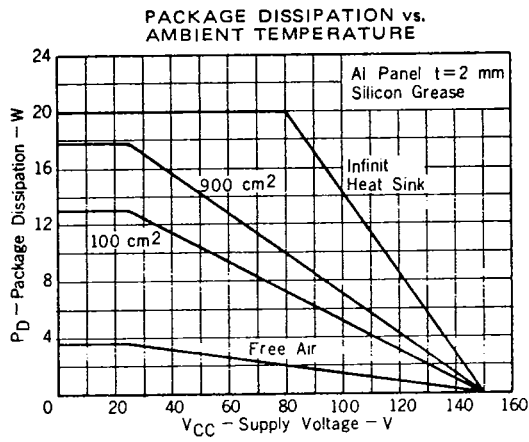

VOLTAGE GAIN, TOTAL HARMONIC DISTORTION vs. FREQUENCY

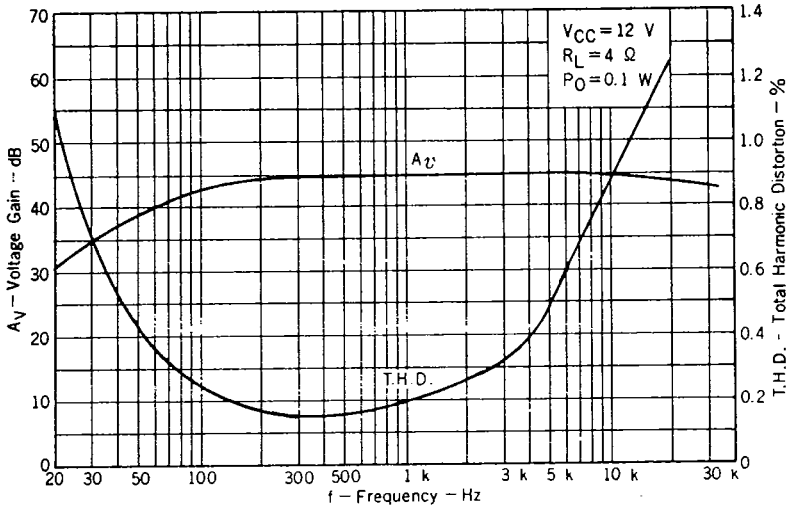

TOTAL HARMONIC DISTORTION vs. OUTPUT POWER

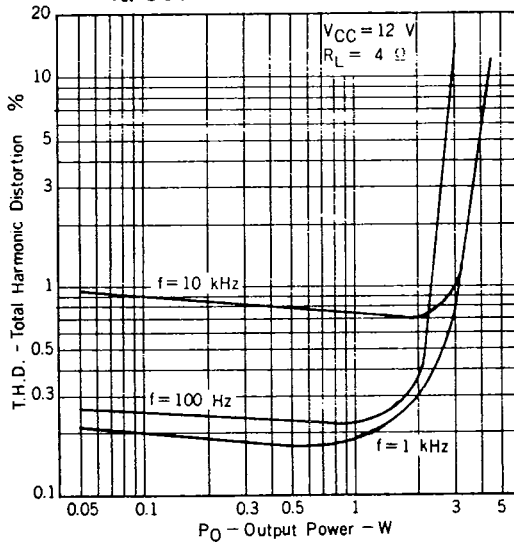

THERMAL CHARACTERISTICS

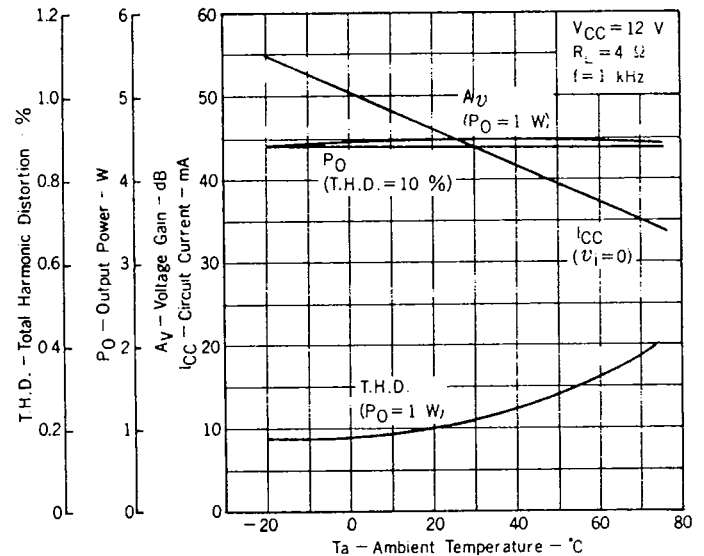

**Note 1)** An inverse connection of the supply voltage pin and the GND pin or a connection of the output pin and either the supply voltage line or GND sometimes causes  $\mu$ PC1277H to break down immediately. Handle it with care.

**Note 2)** GND pins #1 (input side GND) and #12 (output side GND) are separated inside of the IC, therefore connect them on a PCB. Make the input and output common impedance least when designing a PCB.

**Note 3)** Recommend a polyeter Film capacitor as a phase compasated capacitance (0.068  $\mu$ F). Choose larger capacity in case that a long power supply line on a PCB causes the IC a parasitic oscillation.

This datasheet has been downloaded from:

[www.DatasheetCatalog.com](http://www.DatasheetCatalog.com)

Datasheets for electronic components.