



## UM61256A Series

### 32K X 8 High Speed CMOS SRAM

#### Features

- Single +5V power supply
- Access times: 12/15 ns (max.)
- Current: Operating: 180mA (max.)/TAA: 12ns  
150mA (max.)/TAA: 15ns  
Standby: 12mA (max.)
- Full static operation, no clock or refreshing required
- Directly TTL compatible: All inputs and outputs
- Common I/O using three-state output
- Data retention voltage: 3V (min.)
- Available in 28-pin SOJ, SKINNY DIP packages

#### General Description

The UM61256A is a high-speed, low-power 262,144-bit static random access memory organized as 32,768 words by 8 bits and operates on a single 5V power supply. It is built using UMC's high performance CMOS process.

Inputs and three-state outputs are TTL compatible and allow for direct interfacing with common system bus structures.

Minimum standby power is drawn by this device when  $\overline{CE}$  is at a high level, independent of the other input levels.

Data retention is guaranteed at a power supply voltage as low as 3V.

#### Pin Configuration

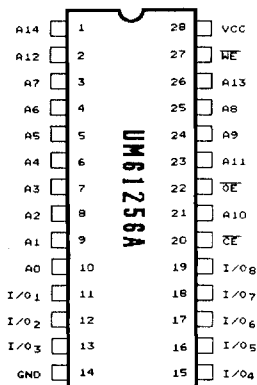

#### Block Diagram

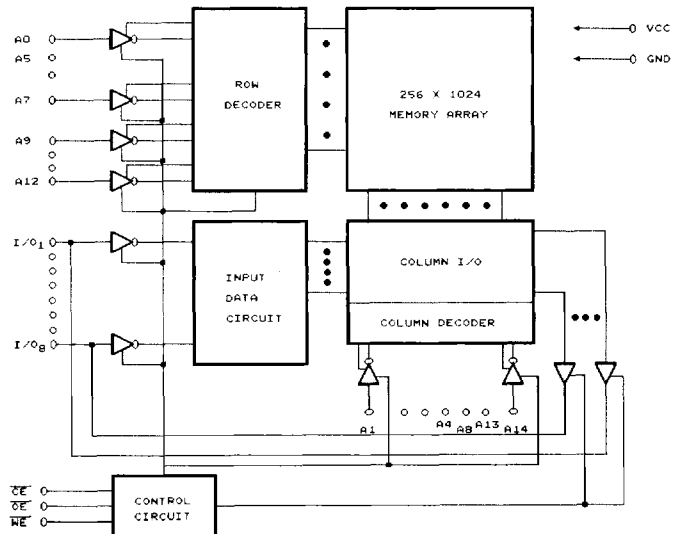

**Pin Description**

Pin No.	Symbol	Description
1-10, 21, 23-26	A0 - A14	Address Input
27	$\overline{WE}$	Write Enable
22	$\overline{OE}$	Output Enable
20	$\overline{CE}$	Chip Enable
11-13, 15-19	I/O <sub>1</sub> - I/O <sub>8</sub>	Data Input/Output
28	VCC	Power Supply
14	GND	Ground

**Recommended DC Operating Conditions**

 (T<sub>A</sub> = 0°C to + 70°C)

Symbol	Parameter	Min.	Typ.	Max.	Unit
VCC	Supply Voltage	4.5	5.0	5.5	V
GND	Ground	0	0	0	V
V <sub>IH</sub>	Input High Voltage	2.2	3.5	VCC + 0.5	V
V <sub>IL</sub>	Input Low (1) Voltage	-0.5	0	+0.8	V
C <sub>L</sub>	Output Load	-	-	30	pF
TTL	Output Load	-	-	1	-

**Absolute Maximum Ratings\***

VCC to GND . . . . . -0.5V to +7.0V  
 IN, IN/OUT Volt to GND . . . . . -0.5V to VCC +0.5V  
 Operating Temperature, T<sub>opr</sub> . . . . . 0°C to +70°C  
 Storage Temperature, T<sub>stg</sub> . . . . . -55°C to +125°C  
 Temperature Under Bias, T<sub>bias</sub> . . . . . -10°C to +85°C  
 Power Dissipation, P<sub>t</sub> . . . . . 1.0W

**\*Comments**

Stresses above those listed under "Absolute Maximum Ratings" may cause permanent damage to the device. These are stress ratings only. Functional operation of this device at these or any other conditions above those indicated in the operational sections of this specification is not implied and exposure to absolute maximum rating conditions for extended periods may affect device reliability.

**DC Electrical Characteristics** (T<sub>A</sub> = 0°C to + 70°C, VCC = 5V ± 10%, GND = 0V)

Symbol	Parameter	UM61256A-12		UM61256A-15		Unit	Conditions
		Min.	Max.	Min.	Max.		
I <sub>LI</sub>	Input Leakage	-	2	-	2	μA	V <sub>IN</sub> = GND to VCC
I <sub>LO</sub>	Output Leakage	-	2	-	2	μA	$\overline{CE} = V_{IH}$ or $\overline{OE} = V_{IH}$ V <sub>I/O</sub> = GND to VCC
I <sub>CC1</sub>	Dynamic Operating Current	-	180	-	150	mA	$\overline{CE} = V_{IL}$ , I <sub>I/O</sub> = 0mA
I <sub>SB</sub>	Standby Power Supply Current	-	35	-	35	mA	$\overline{CE} = V_{IH}$
I <sub>SB1</sub>		-	12	-	12	mA	$\overline{CE} \geq VCC - 0.2V$ V <sub>IN</sub> ≥ VCC - 0.2V or V <sub>IN</sub> ≤ 0.2V

**DC Electrical Characteristics (continued)**

Symbol	Parameter	UM61256A-12		UM61256A-15		Unit	Conditions
		Min.	Max.	Min.	Max.		
V <sub>OL</sub>	Output Low Voltage	-	0.4	-	0.4	V	I <sub>OL</sub> = 8 mA
V <sub>OH</sub>	Output High Voltage	2.4	-	2.4	-	V	I <sub>OH</sub> = -4 mA

Note: 1. V<sub>IL</sub> = -3.0V for pulses less than 20 ns.  
 2. I<sub>CC1</sub> is dependent on output loading, cycle rates, and Read/Write patterns.

**Truth Table**

Mode	$\overline{\text{CE}}$	$\overline{\text{OE}}$	$\overline{\text{WE}}$	I/O Operation	Supply Current
Standby	H	X	X	High Z	I <sub>SB</sub> , I <sub>SB1</sub>
Output Disable	L	H	H	High Z	I <sub>CC</sub> , I <sub>CC1</sub>
Read	L	L	H	DOUT	I <sub>CC</sub> , I <sub>CC1</sub>
Write	L	X	L	DIN	I <sub>CC</sub> , I <sub>CC1</sub>

Note: X: H or L

**Capacitance** (T<sub>A</sub> = 25°C, f = 1.0 MHz)

Symbol	Parameter	Min.	Max.	Unit	Conditions
C <sub>IN</sub> *	Input Capacitance		10	pF	V <sub>IN</sub> = 0V
C <sub>I/O</sub> *	Input/Output Capacitance		10	pF	V <sub>I/O</sub> = 0V

\* These parameters are sampled and not 100% tested.

**AC Characteristics** (TA = 0°C to +70°C, VCC = 5V ± 10%)

Symbol	Parameter	UM61256A-12		UM61256A-15		Unit
		Min.	Max.	Min.	Max.	
<b>Read Cycle</b>						
t <sub>RC</sub>	Read Cycle Time	12	–	15	–	ns
t <sub>AA</sub>	Address Access Time	–	12	–	15	ns
t <sub>ACE</sub>	Chip Enable Access Time	–	12	–	15	ns
t <sub>OE</sub>	Output Enable to Output Valid	–	7	–	9	ns
t <sub>CLZ</sub>	Chip Enable to Output in Low Z	2	–	3	–	ns
t <sub>OLZ</sub>	Output Enable to Output in Low Z	2	–	2	–	ns
t <sub>CHZ</sub>	Chip Disable to Output in High Z	0	7	0	8	ns
t <sub>OHZ</sub>	Output Disable to Output in High Z	2	6	2	7	ns
t <sub>OH</sub>	Output Hold from Address Change	2	–	3	–	ns
<b>Write Cycle</b>						
t <sub>WC</sub>	Write Cycle Time	12	–	15	–	ns
t <sub>CW</sub>	Chip Enable to End of Write	10	–	12	–	ns
t <sub>AS</sub>	Address Setup Time of Write	0	–	0	–	ns
t <sub>AW</sub>	Address Valid to End of Write	10	–	12	–	ns
t <sub>WP</sub>	Write Pulse Width	8	–	10	–	ns
t <sub>WR</sub>	Write Recovery Time	0	–	0	–	ns



**AC Characteristics (continued)**

Symbol	Parameter	UM61256A-12		UM61256A-15		Unit
		Min.	Max.	Min.	Max.	
$t_{WHZ}$	Write to Output in High Z	0	7	0	8	ns
$t_{DW}$	Data to Write Time Overlap	8	-	10	-	ns
$t_{DH}$	Data Hold from Write Time	0	-	0	-	ns
$t_{OW}$	Output Active from End of Write	5	-	5	-	ns

Notes:  $t_{CHZ}$ ,  $t_{OHZ}$  and  $t_{WHZ}$  are defined as the time at which the outputs achieve the open circuit condition and are not referred to output voltage levels.

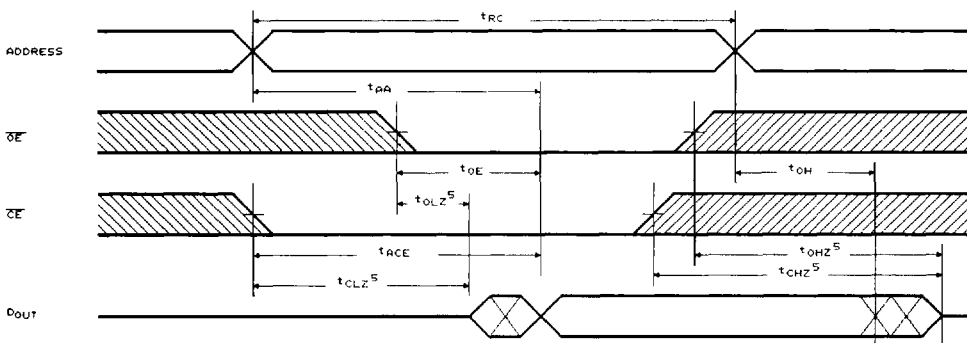
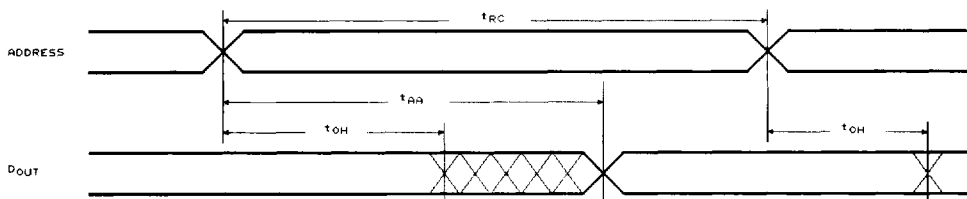
**Timing Waveforms**
**Read Cycle 1<sup>(1)</sup>**

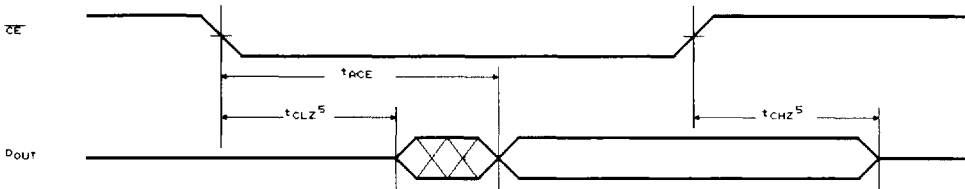
**Read Cycle 2<sup>(1, 2, 4)</sup>**

**Timing Waveforms (continued)**
**Read Cycle 3<sup>(1, 3, 4)</sup>**

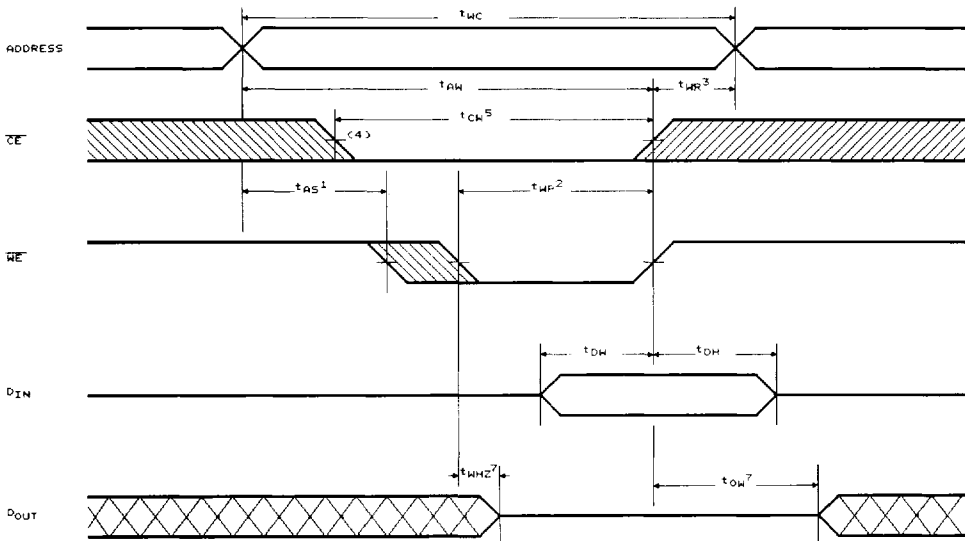
- Notes:
1.  $\overline{WE}$  is high for Read Cycle.
  2. Device is continuously enabled,  $\overline{CE} = V_{IL}$ .
  3. Address valid prior to or coincident with  $\overline{CE}$  transition low.
  4.  $\overline{OE} = V_{IL}$ .
  5. Transition is measured  $\pm 50\text{mV}$  from steady state. This parameter is sampled and not 100% tested.

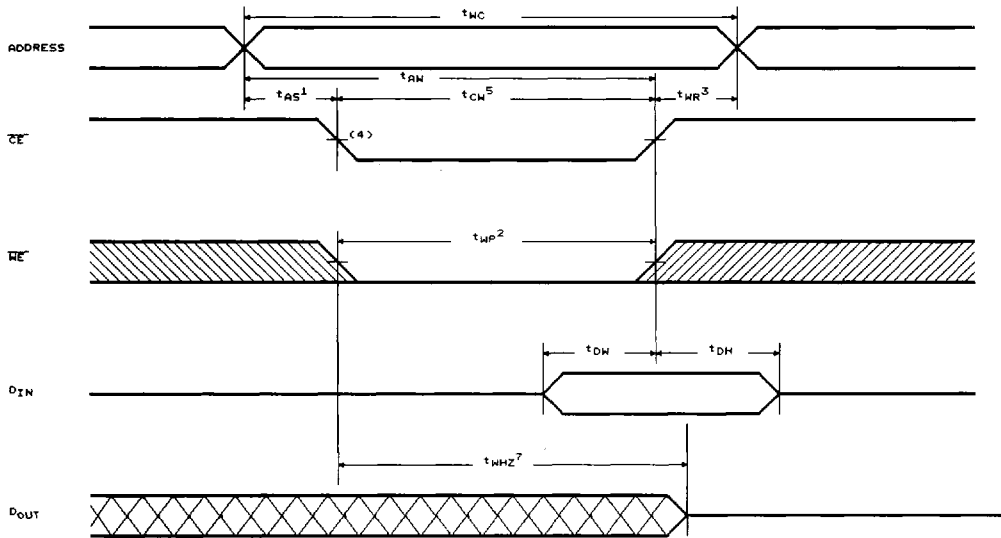
**Write Cycle 1<sup>(6)</sup>**  
**(Write Enable Controlled)**

**Timing Waveforms (continued)**
**Write Cycle 2  
(Chip Enable Controlled)**

- Notes:
1.  $t_{AS}$  is measured from the address valid to the beginning of Write.
  2. A Write occurs during the overlap ( $t_{WP}$ ) of a low  $\overline{CE}$  and a low  $\overline{WE}$ .
  3.  $t_{WR}$  is measured from the earliest of  $\overline{CE}$  or  $\overline{WE}$  going high to the end of the Write cycle.
  4. If the  $\overline{CE}$  low transition occurs simultaneously with the  $\overline{WE}$  low transition or after the  $\overline{WE}$  transition, outputs remain in a high impedance state.
  5.  $t_{CW}$  is measured from the later of  $\overline{CE}$  going low to the end of Write.
  6.  $\overline{OE}$  is continuously low ( $\overline{OE} = V_{IL}$ ).
  7. Transition is measured  $\pm 500\text{mV}$  from steady state. This parameter is sampled and not 100% tested.

**AC Test Conditions**

Input Pulse Levels	0V to 3.0V
Input Rise and Fall Time	5 ns
Input and Output Timing Reference Levels	1.5V
Output Load	See Fig. 1, 2

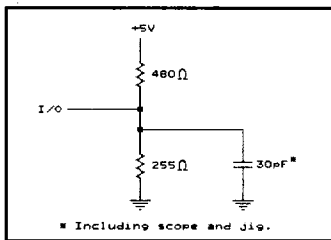
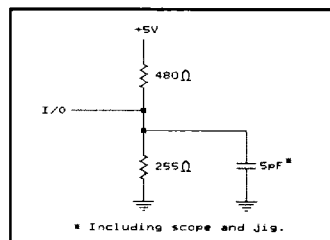
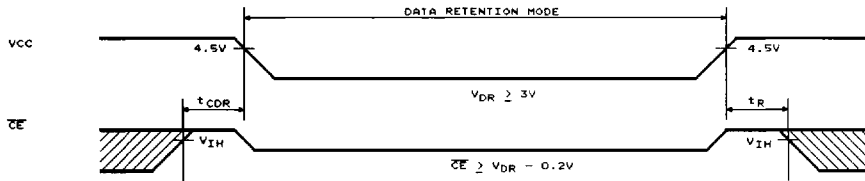

**Figure 1. Output Load**

**Figure 2. Output Load for tCLZ, toLZ, tCHZ, toHZ, tWHZ, and toW**
**Data Retention Characteristics** (TA = 0°C to 70°C)

Symbol	Parameter	Min.	Max.	Unit	Conditions
VDR	VCC for Data Retention	3	5.5	V	$\overline{CE} \geq VCC - 0.2V$
ICCDR	Data Retention Current	-	12	mA	VCC = 3.0V, $\overline{CE} \geq VCC - 0.2V$ $V_{IN} \geq VCC - 0.2V$ or $V_{IN} \leq 0.2V$
t <sub>CDR</sub>	Chip Disable to Data Retention Time	0	-	ns	See Retention Waveform
t <sub>R</sub>	Operation Recovery Time	t <sub>RC</sub> *	-	ns	

\* t<sub>RC</sub> = Read Cycle Time

High Speed SRAM



**Low VCC Data Retention Waveform**

**Ordering Information**

Part No.	Access Time (ns)	Operating Current Max. (mA)	Standby Current Max. (mA)	Package
UM61256AK-12	12	180	12	28L SKINNY
UM61256AS-12	12	180	12	28L SOJ
UM61256AK-15	15	150	12	28L SKINNY
UM61256AS-15	15	150	12	28L SOJ