

ABSOLUTE MAXIMUM RATINGS

STP, VDD, DRV Voltage	-0.3V to 25V
All Other Pins Voltage	-0.3V to 6V
Storage Temperature	-55°C to 150°C
Junction Temperature (Tj)	150°C

Recommended operating conditions

Supply voltage	7.2V to 18V
Operating Temperature	-40°C to 105°C

Thermal resistance^①

Junction to case (R _{θJC})	128°C/W
--------------------------------------	---------

Note:

- ① R_{θJC} is measured in the natural convection at TA = 25°C on a low effective single layer thermal conductivity test board of JEDEC 51-3 thermal measurement standard. Test condition: Device mounted on 2" X 2" FR-4 substrate PCB, 2oz copper, with minimum recommended pad on top layer and thermal vias to bottom layer ground plane.

PIN CONFIGURATIONS

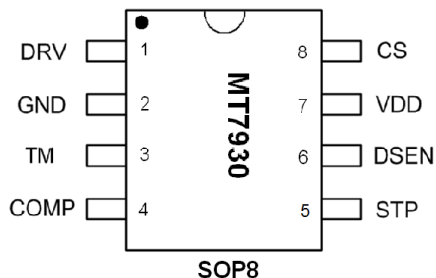

Chip Mark

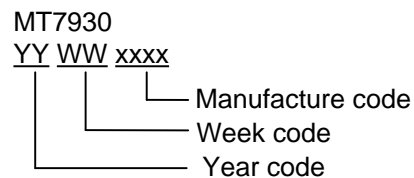

PIN DESCRIPTION

Name	Pin No.	Description
DRV	1	Gate drive output for power N-MOSFET.
GND	2	Ground.
TM	3	Test pin. Always tie to ground.
COMP	4	Internal EA's output. Connect a capacitor to ground for frequency compensation.
STP	5	Start-up Pin. The MT7930 is softly started through STP Pin.
DSEN	6	The voltage feedback from auxiliary winding. Connected to a resistor divider from auxiliary winding reflecting output voltage.
VDD	7	Power Supply.
CS	8	Current Sense pin.

ELECTRICAL CHARACTERISTICS
(Test conditions: $V_{DD}=12V$, $T_A=25^{\circ}C$ unless otherwise stated.)

Symbol	Parameter	Conditions	Min	Typ	Max	Unit
Start-up (STP Pin, VDD Pin)						
I_{START}	Start up Current			25	50	μA
UVLO	Lower Threshold Voltage of V_{DD}	V_{DD} Pin ramp down	6.0	7.2	8.5	V
V_{START}	Start-up Voltage	V_{DD} Pin ramp up	15.5	18.5	20	V
Supply Current						
I_q	Quiescent Current	No switching		1.2		mA
I_{cc}	Operating Current ^②	$F_s=70kHz$ / 500pF Gate capacitor of power N-MOSFET		3		mA
Control Loop						
V_{FB}	Primary Current Sense Voltage		392	400	408	mV
V_{COMP}	Upper Limit of COMP		2.1	2.2	2.4	V
T_{OFF}	Off Time of DRV		10	11	12	μS
SCP	Short Circuit Protection Threshold at DSEN pin		190	200	210	mV
OVP1	Over Voltage Protection Threshold at DSEN		3.04	3.2	3.36	V
OVP2	Over Voltage Protection Threshold at VDD pin		18.2	19.2	23.5	V
Current Sense (CS Pin)						
LEB	Leading Edge Blanking of CS			300		nS
OCP	Over Current Protection at CS pin			2.2	2.4	V
Thermal Protection						
OTP	Over temperature protection			150		$^{\circ}C$
	Over temperature release hysteresis			15		$^{\circ}C$
Drive Stage (DRV Pin)						
T_R	Rising Time	$C_L=1nF$, DRV Pin Falls from V_{DD} to 0V		50 ^③		nS
T_F	Falling Time	$C_L=1nF$, DRV Pin Rises from 0V to V_{DD}		30 ^③		nS

Note:

②sensitive with the frequency of system operating and capacitance on the Gate of external power MOSFET

③Guaranteed by design.

BLOCK DIAGRAM

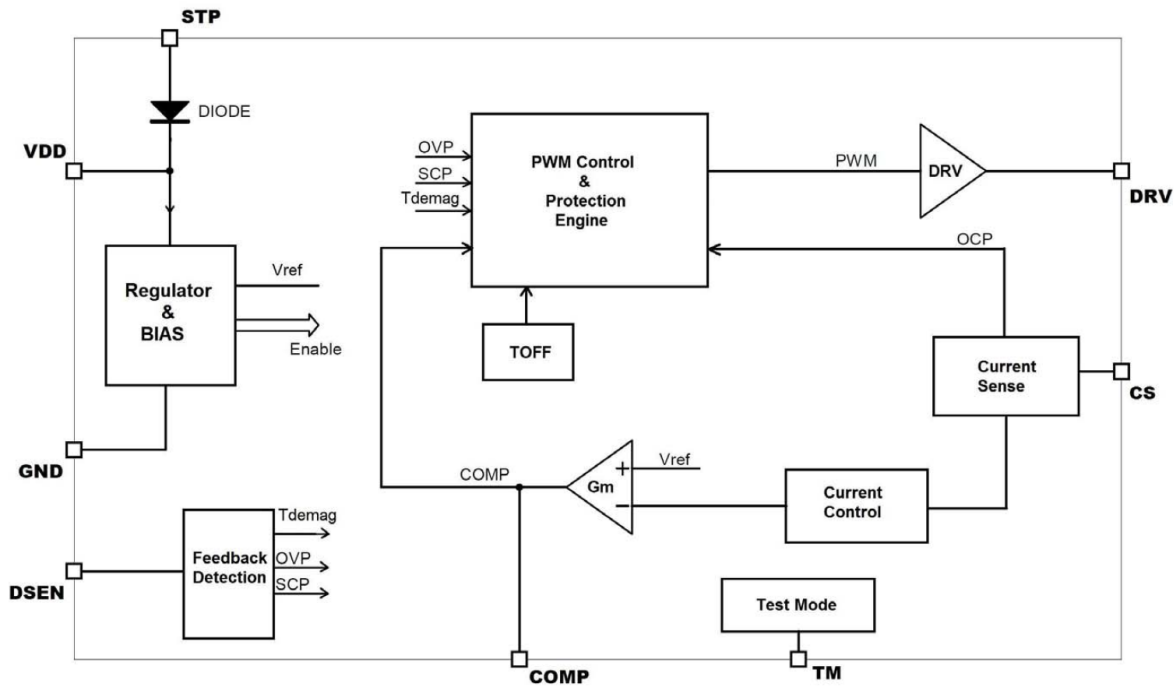

APPLICATION INFORMATION

MT7930 is a primary-side controller for AC-DC LED driver. The LED current can be accurately regulated through sensing the primary side information to realize real current control. MT7930 integrates power factor correction function to eliminate pollution to the AC line and works in DCM and constant OFF time mode.

Real Current Control

With MAXIC proprietary technique, MT7930 accurately regulate LED current through sensing the primary side information. The LED current can be easily set as following (refer to the application circuit in page 1):

$$I_{LED} = 0.94 \times \frac{1}{2} \times \frac{N_P}{N_S} \times \frac{V_{FB}}{R_S}$$

Where N_P is primary winding, N_S is secondary winding; V_{FB} (=400mV) is the internal voltage reference and R_S is an external current sensing resistor (R_S is R_4 in page1 application circuit).

Start Up

During start-up process, VDD is charged through a start-up resistor. As VDD reaches 18.5V, the control logic starts to work, and the gate drive begins to switch. A soft-start function is implemented to prevent the transformer from entering into CCM (continuous current mode) as show in Fig.1.

The power supply is taken over by the auxiliary winding once the voltage of this winding is high enough.

After MT7930 control logic starts to work, STP pin is clamped to lower than VDD voltage about 0.2V.

MT7930 will shut down if VDD goes below 7.2V (UVLO threshold voltage).

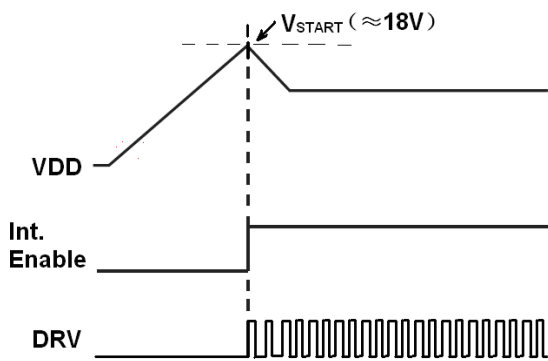

Fig.1 Start up sequence

Power Factor Correction

The primary side current increases linearly from zero to peak value, as sensed by the current sensing pin CS, during the external MOSFET on-time. When the primary current reaches the threshold, MT7930 turns off the power MOSFET immediately. After a constant OFF time, T_{OFF}, MT7930 turns on the power MOSFET again. The peak current threshold is regulated by MAXIC proprietary technique and follows the rectified sinusoidal-shape of input voltage. As a result, the envelope of the inductor current is sinusoidal-shaped, high power factor is therefore achieved in this way.

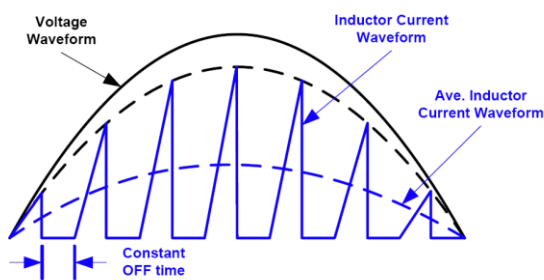

Fig.2 Power Factor Correction

Auxiliary Sensing

MT7930 features over-voltage protection (OVP), short-circuit protection (SCP), and over-current protection (OCP) functions. Those protections are triggered by sensing the auxiliary winding waveform information, as the auxiliary winding voltage is proportional to the output voltage

(secondary winding voltage) during the OFF time period. The auxiliary winding voltage is sampled by DSEN pin, one LEB (Leading Edge Blanking) time right after DRV signal is turned off.

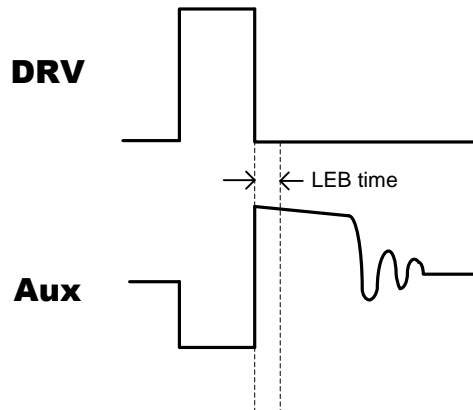

Fig.3 Auxiliary Signal Sensing

Over-voltage Protection

MT7930 is implemented with two over-voltage protection schemes: (1) If DSEN pin's voltage is detected above 3.2V for three times (refer to **Auxiliary Sensing** section), MT7930 turns off the PWM switching signal, and VDD voltage gradually drops to UVLO threshold, and the system will be re-started. The threshold voltage of over-voltage protection V_{OUT_OV}, can be easily defined as (refer to the application circuit in page 1):

$$V_{OUT_OV} = 3.2 \times \left(1 + \frac{R5}{R6}\right) \times \frac{N_s}{N_a} - V_{D8}$$

Where N_s is the secondary winding, N_a is auxiliary winding, V_{D8} is the forward bias of the secondary side rectifier diode.

(2) If VDD pin's voltage exceeds 19.2V three times, MT7930 turns off the PWM switching signal, and VDD gradually drops to UVLO threshold, and then the system will be re-started. It is highly recommended to set up the VDD voltage between 12V and 16V by designed a proper N_a to N_s ratio of the transformer.



Maximizing IC Performance

MT7930

Single Stage, High PFC, AC-DC LED Driver

Short-circuit Protection

The short-circuit protection is triggered if the DSEN pin voltage is detected below 200mV for a continuous time of 10ms. The gate drive switching will be turned off, and a restart process will be kicked off when the VDD voltage drops below the UVLO threshold.

This re-start process will repeat if the short-circuit condition continues to exist.

Over-current Protection

MT7930 immediately turns off the power MOSFET once the voltage at CS pin exceeds 2.2V. This cycle by cycle current limitation scheme prevents the relevant components, such as power MOSFET, transformer, etc. from damage.

PACKAGE INFORMATION

SOP-8 PACKAGE OUTLINE AND DIMENSIONS

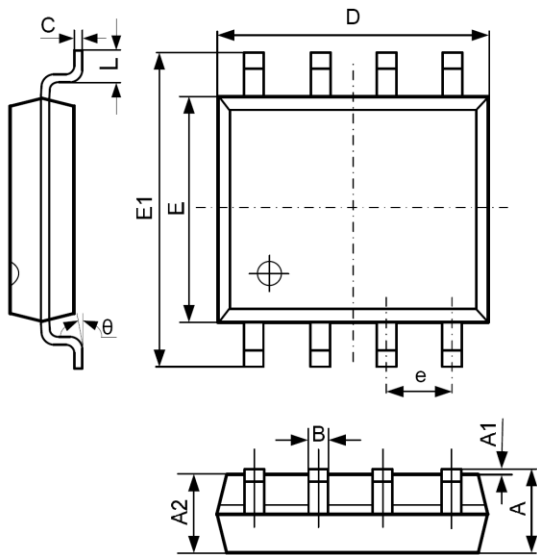

SYMBOL	DIMENSION IN MILLIMETERS		DIMENSION IN INCHES	
	MIN	MAX	MIN	MAX
A	1.350	1.750	0.053	0.069
A1	0.100	0.250	0.004	0.010
A2	1.350	1.550	0.053	0.061
B	0.330	0.510	0.013	0.020
C	0.190	0.250	0.007	0.010
D	4.700	5.100	0.185	0.201
E	3.800	4.000	0.150	0.157
E1	5.800	6.300	0.228	0.248
e	1.270 TYP		0.050 TYP	
L	0.400	1.270	0.016	0.050
θ	0°	8°	0°	8°

Important Notice

- Maxic Technology Corporation (Maxic) reserve the right to make correction, modifications, enhancements, improvements and other changes to its products and services at any time and to discontinue any product or service without notice. Customers should obtain the latest relevant information before placing orders and should verify that such information is current and complete. All products are sold subject to Maxic’s terms and conditions of sale supplied at the time of order acknowledgement.
- Reproduction, copying, transferring, reprinting this paper without Maxic’s written permission is prohibited.
- Maxic is not responsible or liable for customer product design by using Maxic components. To minimize the risks and associated with customer products and applications, customers should provide adequate design and operating safeguards and consult Maxic’s sales department.