

NINGBO TIANBO GANGLIAN ELECTRONICS CO., LTD

HJQ-15F SPECIFICATION

FILE NUMBER: T810S-G006A

DATE: 2004/06/25

■ CONTACT DATA

Contact Form	1A,1B,1C	
Contact Material	Silver Alloy	
Contact Ratings	1A: 25A 240VAC/20A 28VDC 30A240VAC 1B: 15A 240VAC/10A 28VDC 20A240VAC 1C:20/10A 240VAC/28VDC	
Max Switching Voltage	250VAC/30VDC	
Max Switching Current	30A	
Max Switching Power	6000VA/560W	
Contact Resistance	100m Ω Max	at 6VDC 1A
Life Expectancy Electrical	100, 000	Operations(at30Operations/minute)
Mechanical	10, 000, 000	Operations

■ GENERAL DATA

Insulation Resistance	100M Ω Min at 500VDC	
Dielectric Strength Between Open Contacts	1500VAC (1min 1mA)	
Between Contacts and coil	1500VAC (1min 1mA)	
Operate Time	15ms	
Release Time	10ms	
Temperature Range	-40°C to +70°C	
Shock Resistance	Operating Extremes	10G
	Damage Limits	100G
Vibration Resistance	10-55Hz, 1.5mm	
Humidity	40-85%	
Weight	Approx. 36g	
Safety Standard	CCEE:CH0064848-2001 ;UL,TUV	

■ COIL DATA

Nominal Voltage (VDC)	Coil Resistance at 20°C \pm 10% (Ω)			Max Operate Voltage VDC	Min Release Voltage VDC	Max Applicable Voltage VDC
			0.93W			
5			26.9	3.75	0.5	6.5
6			38.8	4.5	0.6	7.8
9			87.1	6.75	0.9	11.7
12			154.9	9	1.2	15.6
18			348.0	13.5	1.8	23.4
24			619.4	18	2.4	31.2
48			2477.5	36	4.8	62.4

ORDERING CODE

HJQ-15F — 12VDC — S — Z

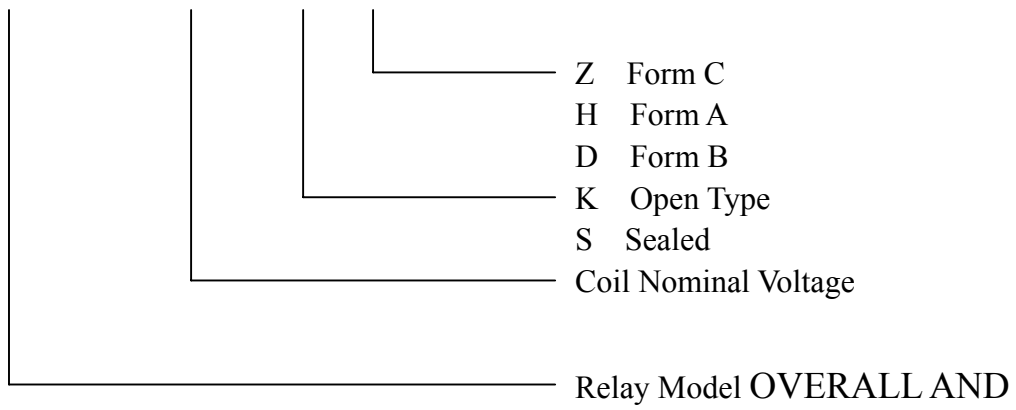

MOUNTING DIMENSIONS

HJQ-15F

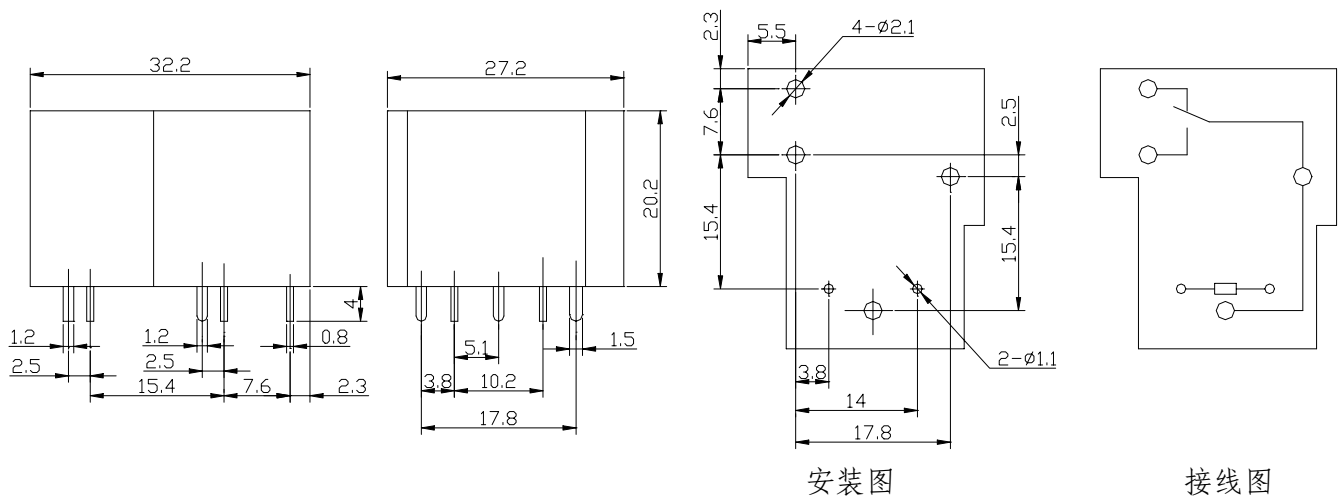

HJQ-15F(Open Type)

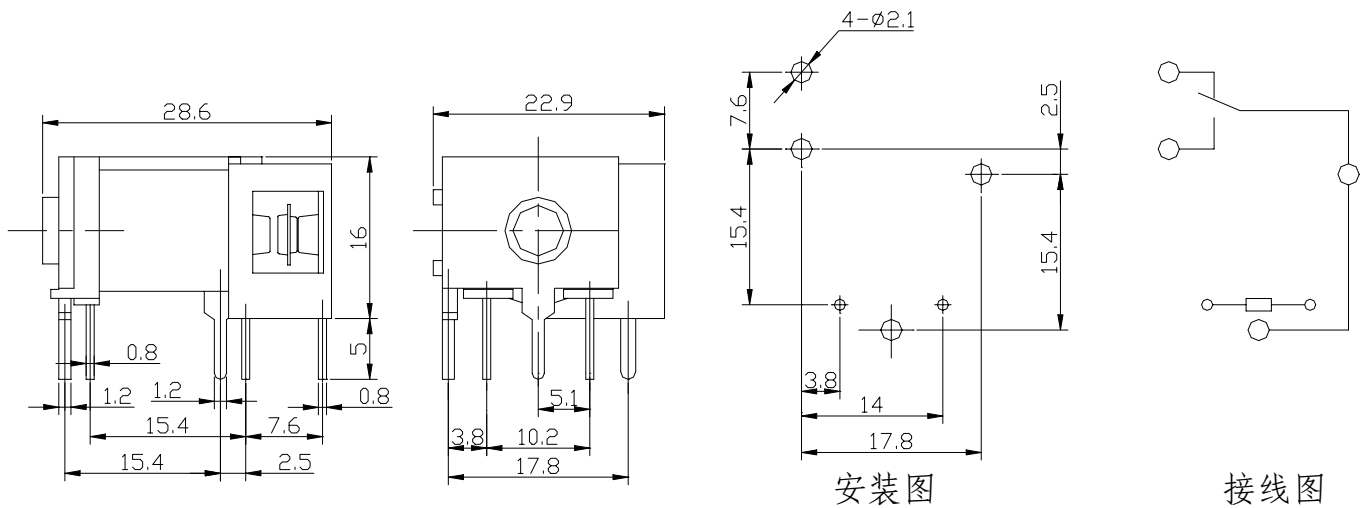

HJQ-15F(H)

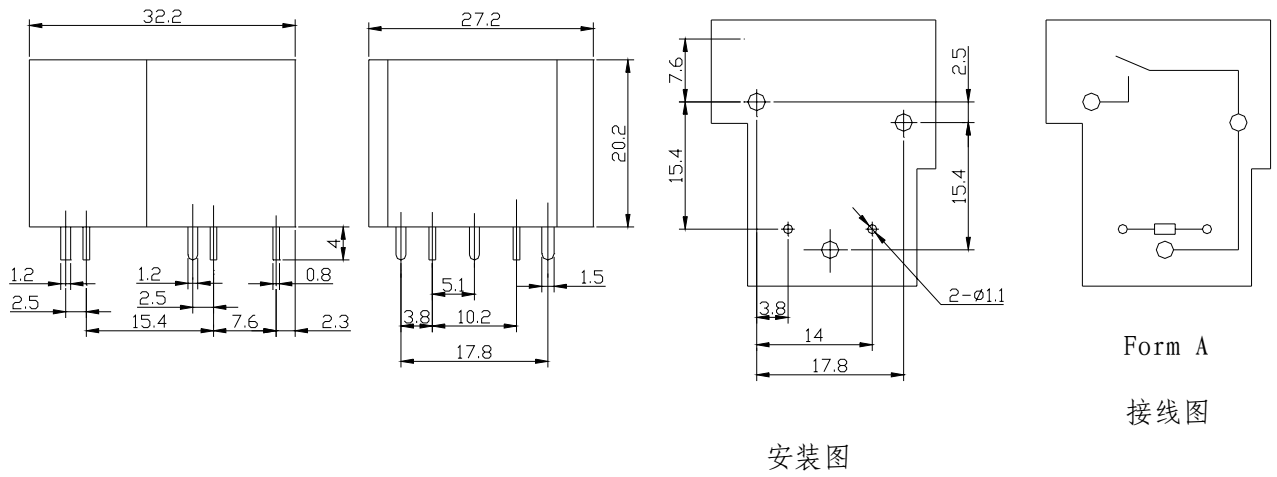

HJQ-15F(Open Type)

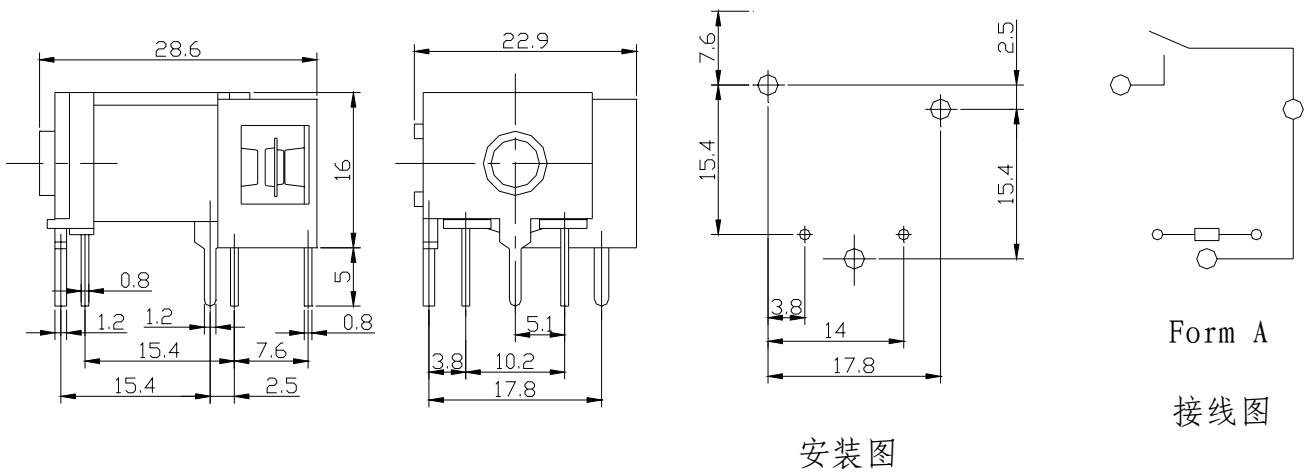

HJQ-15F(N)

