

General Description

SDC606 is a high-performance current mode control IC designed for AC/DC convertor, which supplies about continuous 12W output power at the universal AC input range from 85V to 265V.

Features

- Built-in oscillator
- Built-in high voltage power transistor of 700V
- High voltage start-up
- Very low start-up and operating current
- Low standby power consumption
- Protections: OVP, UVLO, SCP, OLP and OTP
- Built-in high precise current limit with temperature compensation
- 12W and peak 15W output power at the universal AC input range
- 15W and peak 18W output power at AC input 220V
- Very few external components
- Package: DIP-8

Applications

- Portable rechargeable power supply
- Appliance controller power supply
- Adaptor/charger for cell and other portable apparatus
- DVD/DVB power supply, ATX standby power supply

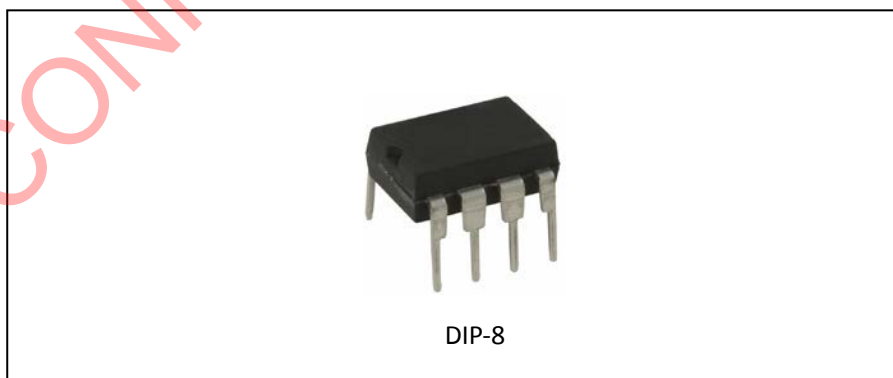

Figure 1. Package Type

Pin Configuration

Figure 2. Pin Configuration

Pin Number	Pin Name	Function
1	OB	Startup current input, connecting to startup resistor
2	VCC	Supply voltage pin
3	GND	Ground
4	NC	NC
5	FB	Feedback pin
6	IS	Cycle-by-cycle current limit, connecting a resistor to GND
7,8	OC	Output of HV transistor, connecting to primary wind of transformer

Table 1. Pin Description

Functional Block Diagram

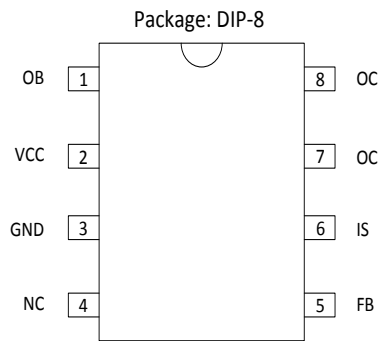
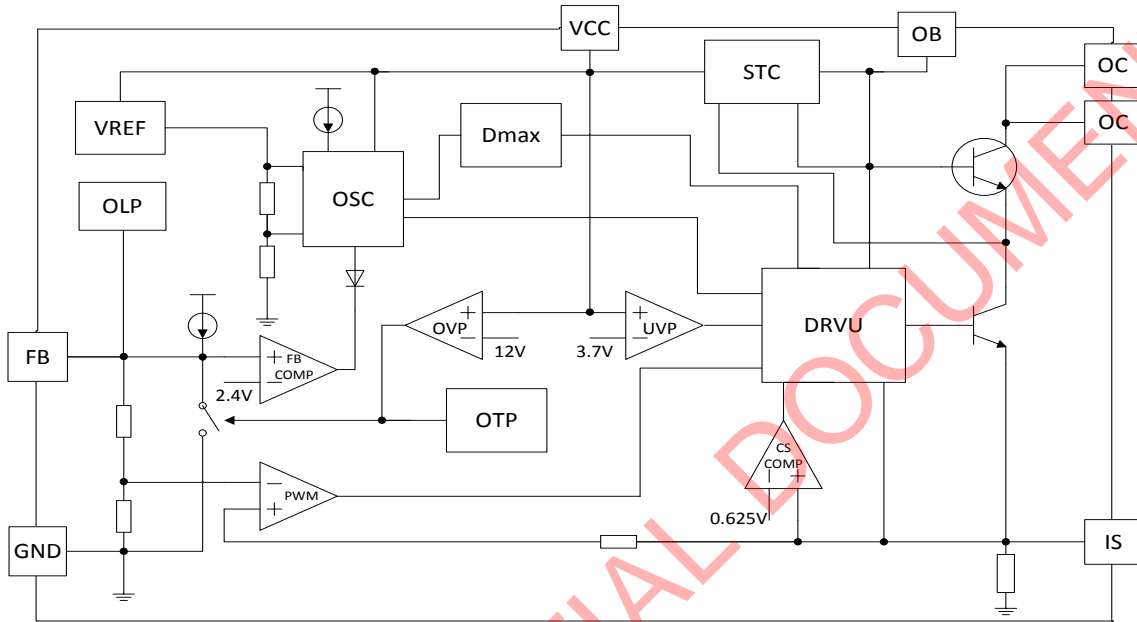
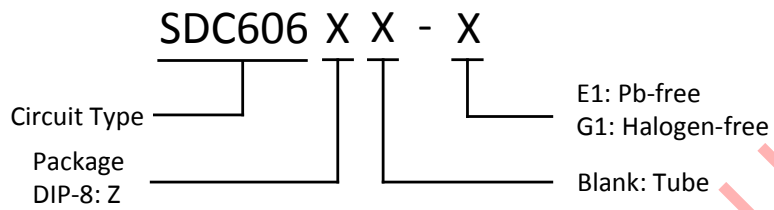

Figure 3. Functional Block Diagram

Ordering Information

Package	Temperature	Part Number		Marking ID		Packing Type
		Pb-free	Halogen-free	Pb-free	Halogen-free	
DIP-8	-40°C~85°C	SDC606Z-E1	SDC606Z-G1	SDC606	SDC606G	Tube

SDC CONFIDENTIAL DOCUMENT

Absolute Maximum Ratings (NOTE: Stresses greater than those listed under Absolute Maximum Ratings may cause permanent damage to the device.)

Parameter	Symbol	Value	Unit
Power supply voltage VCC	V_{CC}	18	V
Endurance voltage of OC collector	V_{CB}	-0.3~700	V
Peak value of switching current	I_p	1000	mA
Total dissipation power	P_D	1000	mW
Collector current	I_c	1.8	A
Operating Junction Temperature	T_J	-40~150	°C
Storage temperature range	T_{STG}	-55~150	°C
Lead temperature (soldering, 10sec)	T_{LEAD}	260	°C
Latch-up test per JEDEC 78	-	200	mA
ESD, HBM model per Mil-Std-883, Method 3015	HBM	2000	V
ESD,MM model per JEDEC EIA/JESD22-A115	MM	200	V

Table 2. Absolute Maximum Ratings

Recommended Operating Conditions

Parameter	Symbol	Min	Max	Unit
Power supply voltage, VCC	V_{CC}	4.5	11.0	V
Operating temperature	T_a	-40	85	°C

Table 3. Recommended Operating Conditions

Electrical Characteristics($T_a=25^{\circ}\text{C}$, $V_{CC}=7.0\text{V}$, $R_{IS}=1\Omega$, unless otherwise specified)

Parameter	Symbol	Conditions	Min	Typ	Max	Unit
Output Section						
On-state saturation voltage drop	V_{SAT}	$I_{OC}=600\text{mA}$	-	-	1	V
Output rise time	T_r	$C_L=1\text{nF}$	-	-	75	ns
Output fall time	T_f	$C_L=1\text{nF}$	-	-	75	ns
HV start-up current	I_{STC}	-	1	-	2.6	mA
Oscillator Section						
Oscillating frequency	f_{osc}	-	55	61	70	kHz
Temperature Stability	ΔF_v	$V_{CC}=4.5\text{V}\sim 11\text{V}$	-	-	1	%
Temperature Stability	ΔF_T	$T_a=0^{\circ}\text{C}\sim 85^{\circ}\text{C}$	-	-	1	%
Feedback Section						
Pull-up current	I_{FB}	$V_{FB}=2.5\text{V}$	0.40	0.50	0.70	mA
Pull-down resistance	R_{FB}	-	10	15	20	k Ω
PSRR	-	$V_{CC}=4.5\text{V}\sim 11\text{V}$	-	60	70	dB
Current Sampling Section						
Over current threshold voltage	$V_{TH,OC}$	-	0.60	0.625	0.65	V
IS-GND resistance	$I_{TH,OC}$	-	15	20	25	Ω
PSRR	PSRR	-	-	60	70	dB
Over current detection and control delay	T_d	-	-	150	250	ns
PWM Section						
Maximum duty cycle	D_{MAX}	$V_{FB}=4.0\text{V}$	52	57	62	%
Minimum duty cycle	D_{MIN}	-	-	1.5	-	%
Power Current Section						
Start-up current	I_{ST}	-	-	15	50	μA
Operating current	I_{OP}	$V_{FB}=0\text{V}$, $V_{CC}=8\text{V}$	2.0	2.8	4.0	mA
Start-up Voltage	V_{ST}	-	8.8	9.2	9.6	V
Under-voltage lockout threshold	V_{UV}	-	3.3	3.7	4.0	V
Restart Voltage	V_{RST}	-	1.7	2.0	2.4	V
Over voltage protection	V_{OV}	-	11	12	13	V
OTP Section						
Thermal shutdown temperature	T_{OTP}	-	-	150	-	$^{\circ}\text{C}$
BJT Section						
Collector cutoff current	I_{CBO}	$V_{CB}=700\text{V}$, $I_E=0$	-	-	0.1	mA
Collector-emitter cutoff current	I_{CEO}	$V_{CE}=450\text{V}$, $I_B=0$	-	-	0.1	mA
Collector-base cutoff current	I_{EBO}	$V_{EB}=9\text{V}$, $I_C=0$	-	-	0.1	mA
Collector-base breakdown voltage	V_{CBO}	$I_C=0.1\text{mA}$	700	-	-	V
Collector-emitter sustain voltage	V_{CEO}	$I_C=1\text{mA}$	450	-	-	V

Parameter	Symbol	Conditions	Min	Typ	Max	Unit
Collector-base sustain voltage	V_{EBO}	$I_E=0.1mA$	9	-	-	V
DC current gain	h_{FE}	$V_{CE}=5V, I_C=0.5A$	15	-	50	-
Collector-emitter saturation voltage	V_{CE_STA}	$I_C=1A, I_B=0.25A$		0.3	0.8	V
Base-emitter saturation voltage	V_{BE_STA}	$I_C=1A, I_B=0.25A$		0.8	1.2	V

Table 4. Electrical Characteristics

SDC CONFIDENTIAL DOCUMENT

Function Description

Startup control

Startup current of SDC606 is designed to be very low so that VCC could be charged up above UVLO threshold level and device starts up quickly. A large startup resistor can therefore be used to minimize the power loss yet achieve a reliable startup in application.

PWM control

The peak current (sensed on the IS pin) is set by the voltage on FB pin. By comparing the voltage on FB pin and the IS ramp voltage, the duty-cycle of the PWM modulator is thus adjusted to provide the necessary load current at the desired output voltage. FB can be controlled by internal control circuit and external feedback circuit.

VCC over voltage protection

VCC over voltage protection circuit is integrated into IC. When VCC voltage reaches 12V(TYP), FB voltage is pulled down via internal control circuit, then the PWM switching is shut off. When VCC voltage goes down below 12V(TYP), the switching is reactivated. The VCC over voltage protection ensures IC to operate reliably.

Current limit

The output is shut off to limit the power when voltage of IS Pin exceeds Current sense threshold voltage.

Green mode control

Under no-load and light-load condition, the switching

frequency internally decreases to lower the switching power loss and improve the conversion efficiency. If FB is less than 2.4V(Typ), the cycle of the oscillator will increase with it, the less FB is, the wider the cycle of the oscillator is, until the oscillation stop.

Power transistor drive

During the ON cycle, OB pin supplies base current for the power transistor, OE pulls down the emitter of the power transistor to IS, and OB is adaptive to the IS current. If the current of IS exceeds the specified current of FB, SDC606 will turn into the OFF cycle. During the OFF cycle, OB is pulled down, the power transistor will shut off.

Over temperature protection

When IC's internal temperature reaches 150°C, FB voltage will be pulled down by internal control circuit, the switching frequency decreases or shut off. This protection protects the IC from over temperature.

Cooling requirements

Layout is important for all switching regulators. To achieve high efficiency, good regulation, and stability, a well designed printed circuit board layout is required. The main power loss inside IC is produced by the internal transistor, an extra copper plane at the pin7 and pin8 help dissipate the heat generated by losses in transistor. For a typical application (AC input from 85V to 265V, 12W output), and 200mm² copper plane is necessary.

Typical Application

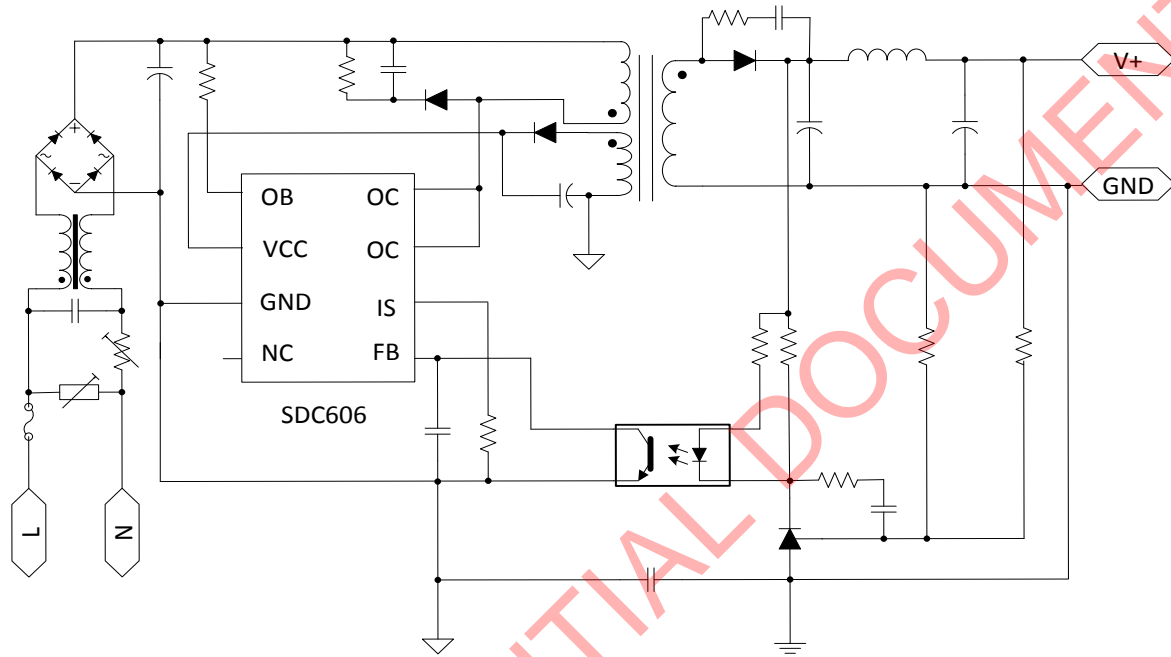
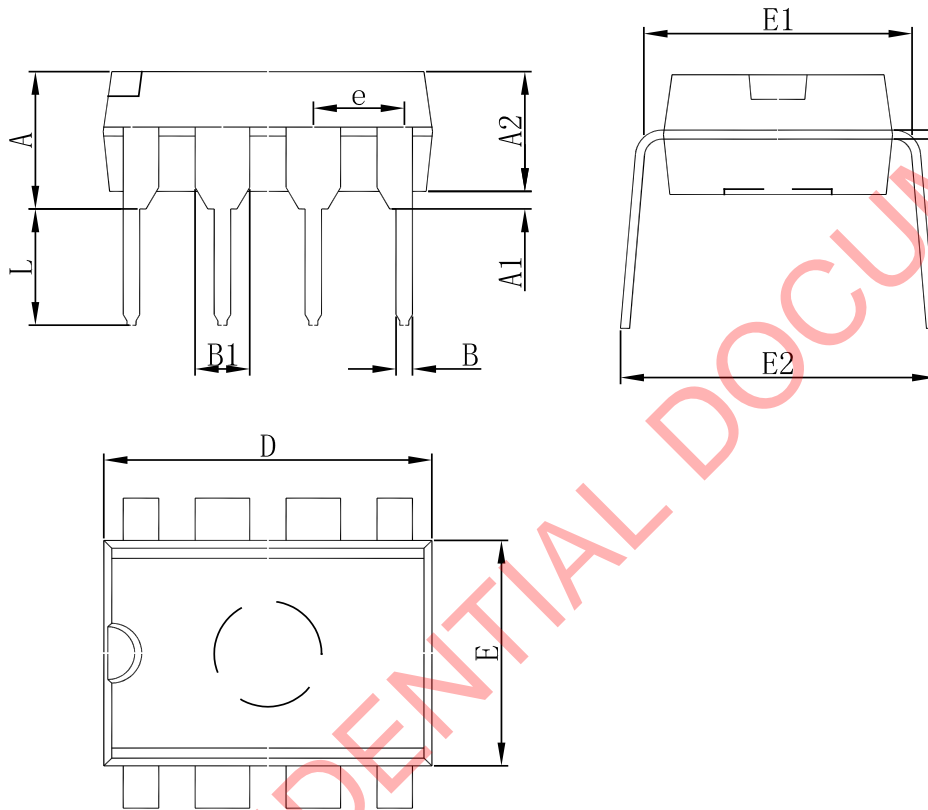

Figure 4. Typical Application

Package Dimension
DIP-8

Symbol	Dimensions In Millimeters		Dimensions In Inches	
	Min	Max	Min	Max
A	3.710	4.310	0.146	0.170
A1	0.510		0.020	
A2	3.200	3.600	0.126	0.142
B	0.380	0.570	0.015	0.022
B1	1.524(BSC)		0.060(BSC)	
C	0.204	0.360	0.008	0.014
D	9.000	9.400	0.354	0.370
E	6.200	6.600	0.244	0.260
E1	7.320	7.920	0.288	0.312
e	2.540(BSC)		0.100(BSC)	
L	3.000	3.600	0.118	0.142
E2	8.400	9.000	0.331	0.354



Shaoxing Devechip Microelectronics Co., Ltd.

<http://www.sdc-semi.com/>

IMPORTANT NOTICE

Information in this document is provided solely in connection with Shaoxing Devechip Microelectronics Co., Ltd. (abbr. SDC) products. SDC reserves the right to make changes, corrections, modifications or improvements, to this document, and the products and services described herein at anytime, without notice. SDC does not assume any responsibility for use of any its products for any particular purpose, nor does SDC assume any liability arising out of the application or use of any its products or circuits. SDC does not convey any license under its patent rights or other rights nor the rights of others.

© 2013 Devechip Microelectronics - All rights reserved

Contact us:

Headquarters of Shaoxing

Address: Tian Mu Road, No13,
Shaoxing city, Zhejiang province, China
Zip code: 312000
Tel: (86) 0575-8861 6750
Fax: (86) 0575-8862 2882

Shenzhen Branch

Address: 22A, Shangbu building, Nan Yuan Road, No.68,
Futian District, Shenzhen city, Guangdong province, China
Zip code: 518031
Tel: (86) 0755-8366 1155
Fax: (86) 0755-8301 8528