

## 2A SWITCHING REGULATOR

### 1 Features

- 2A OUTPUT CURRENT
- 5.1V TO 40V OUTPUT VOLTAGE RANGE
- 0 TO 90% DUTY CYCLE RANGE
- INTERNAL FEED-FORWARD LINE REG.
- INTERNAL CURRENT LIMITING
- PRECISE 5.1V  $\pm$  2% ON CHIP REFERENCE
- RESET AND POWER FAIL FUNCTIONS
- INPUT/OUTPUT SYNC PIN
- UNDER VOLTAGE LOCK OUT WITH HYSTERETIC TURN-ON
- PWM LATCH FOR SINGLE PULSE PER PERIOD
- VERY HIGH EFFICIENCY
- SWITCHING FREQUENCY UP TO 200KHz
- THERMAL SHUTDOWN
- CONTINUOUS MODE OPERATION

### 2 Description

The L4972A is a stepdown monolithic power switching regulator delivering 2A at a voltage variable from 5.1 to 40V.

Realized with BCD mixed technology, the device

Figure 1. Packages

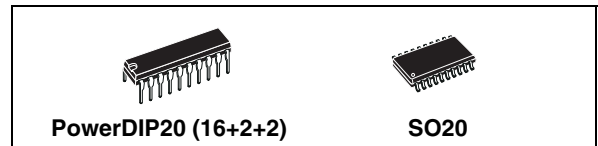

Table 1. Order Codes

Part Number	Package
L4972A	DIP20 (16+2+20)
L4972AD	SO20
L4972AD013TR	SO20 in Tape & Reel

uses a DMOS output transistor to obtain very high efficiency and very fast switching times. Features of the L4972 include reset and power fail for microprocessors, feed forward line regulation, soft start, limiting current and thermal protection. The device is mounted in a Powerdip 16 + 2 + 2 and SO20 large plastic packages and requires few external components. Efficient operation at switching frequencies up to 200KHz allows reduction in the size and cost of external filter component.

Figure 2. Block Diagram

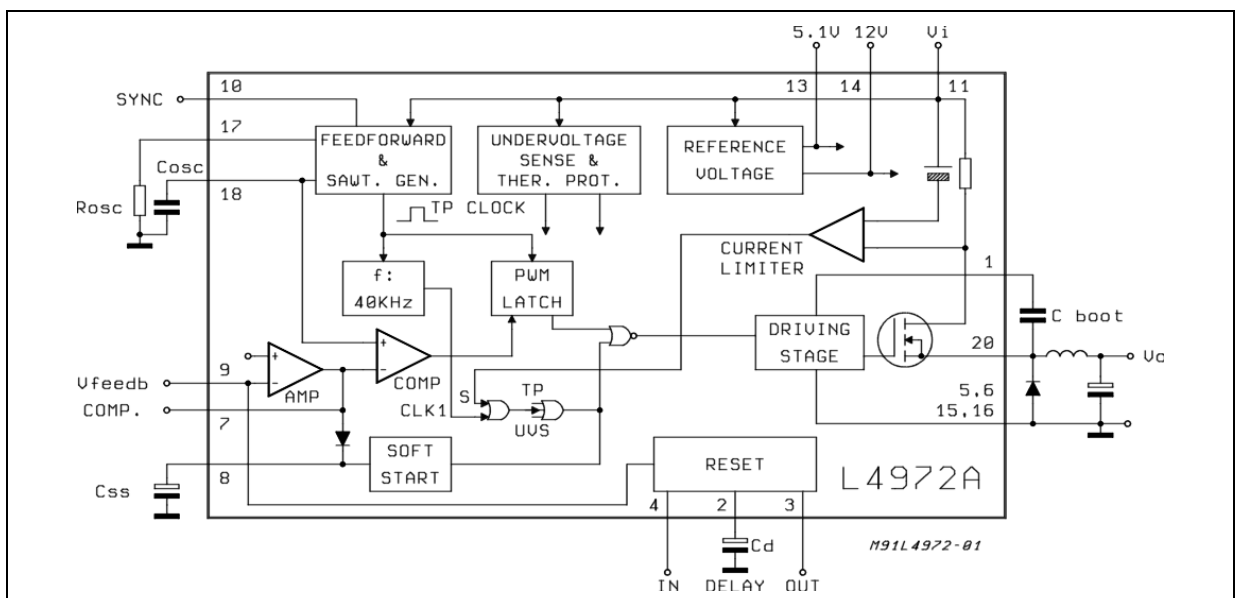
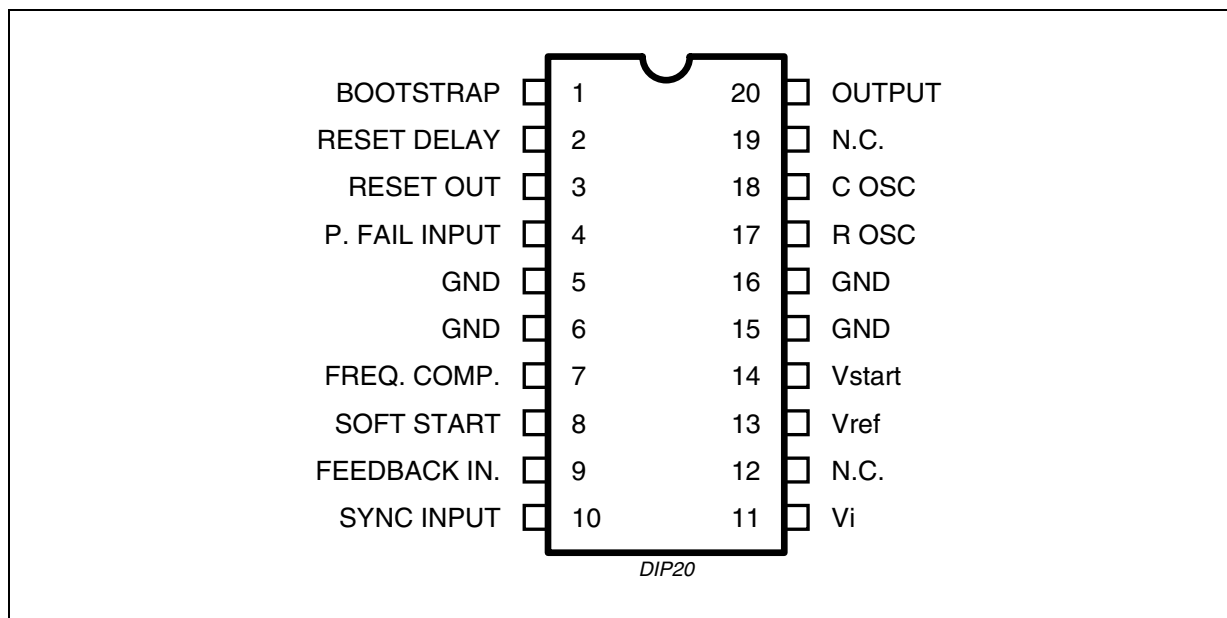

Table 2. Pin Description

N°	Pin	Function
1	BOOTSTRAP	A $C_{boot}$ capacitor connected between this terminal and the output allows to drive properly the internal D-MOS transistor.
2	RESET DELAY	A $C_d$ capacitor connected between this terminal and ground determines the reset signal delay time.
3	RESET OUT	Open Collector Reset/power Fail and the output voltages are safe. Signal Output. This output is high when the supply
4	RESET INPUT	Input of Power Fail Circuit. The threshold is 5.1V. It may be connected via a divider to the input for power fail function. It must be connected to the pin 14 an external 30K $\Omega$ resistor when power fail signal not required.
5, 6 15, 16	GROUND	Common Ground Terminal
7	FREQUENCY COMPENSATION	A series RC network connected between this terminal and ground determines the regulation loop gain characteristics.
8	SOFT START	Soft Start Time Constant. A capacitor is connected between the sterminal and ground to define the soft start time constant.
9	FEEDBACK INPUT	The Feedback Terminal of the Regulation Loop. The output is connected directly to this terminal for 5.1V operation; It is connected via a divider for higher voltages.
10	SYNC INPUT	Multiple L4972A's are synchronized by connecting pin 10 inputs together or via an external syncr. pulse.
11	SUPPLY VOLTAGE	Unregulated Input Voltage.
12, 19	N.C.	Not Connected.
13	$V_{ref}$	5.1V $V_{ref}$ Device Reference Voltage.
14	$V_{start}$	Internal Start-up Circuit to Drive the Power Stage.
17	OSCILLATOR	$R_{osc}$ . External resistor connected to ground determines the constant charging current of $C_{osc}$ .
18	OSCILLATOR	$C_{osc}$ . External capacitor connected to ground determines (with $R_{osc}$ ) the switching frequency.
20	OUTPUT	Regulator Output.

Figure 3. Pin Connection (Top view)



**Table 3. Absolute Maximum Ratings**

Symbol	Parameter	Value	Unit
V <sub>11</sub>	Input Voltage	55	V
V <sub>11</sub>	Input Operating Voltage	50	V
V <sub>20</sub>	Output DC Voltage Output Peak Voltage at t = 0.1μs f = 200kHz	-1 -5	V V
I <sub>20</sub>	Maximum Output Current	Internally Limited	
V <sub>1</sub>	Bootstrap Voltage Bootstrap Operating Voltage	65 V <sub>11</sub> + 15	V V
V <sub>4</sub> , V <sub>8</sub>	Input Voltage at Pins 4, 12	12	V
V <sub>3</sub>	Reset Output Voltage	50	V
I <sub>3</sub>	Reset Output Sink Current	50	mA
V <sub>2</sub> , V <sub>7</sub> , V <sub>9</sub> , V <sub>10</sub>	Input Voltage at Pin 2, 7, 9, 10	7	V
I <sub>2</sub>	Reset Delay Sink Current	30	mA
I <sub>7</sub>	Error Amplifier Output Sink Current	1	A
I <sub>8</sub>	Soft Start Sink Current	30	mA
P <sub>tot</sub>	Total Power Dissipation at T <sub>PINS</sub> ≤ 90°C at Tamb = 70°C (No copper area on PCB)	5 / 3.75(*) 1.3/1 (*)	W W
T <sub>J</sub> , T <sub>stg</sub>	Junction and Storage Temperature	-40 to 150	°C

(\*) SO-20

**Table 4. Thermal Data**

Symbol	Parameter	PowerDIP	SO20	Unit
R <sub>th j-pins</sub>	Thermal Resistance Junction-Pins	max, 12	16	°C/W
R <sub>th j-amb</sub>	Thermal Resistance Junction-ambient	max, 60	80	°C/W

### 3 Circuit Operation

The L4972A is a 2A monolithic stepdown switching regulator working in continuous mode realized in the new BCD Technology. This technology allows the integration of isolated vertical DMOS power transistors plus mixed CMOS/Bipolar transistors.

The device can deliver 2A at an output voltage adjustable from 5.1V to 40V and contains diagnostic and control functions that make it particularly suitable for microprocessor based systems.

#### 3.1 BLOCK DIAGRAM

The block diagram shows the DMOS power transistors and the PWM control loop. Integrated functions include a reference voltage trimmed to 5.1V ± 2%, soft start, undervoltage lockout, oscillator with feedforward control, pulse by pulse current limit, thermal shutdown and finally the reset and power fail circuit. The reset and power fail circuit provides an output signal for a microprocessor indicating the status of the system.

Device turn on is around 11V with a typical 1V hysteresis, this threshold provides a correct voltage for the driving stage of the DMOS gate and the hysteresis prevents instabilities.

An external bootstrap capacitor charge to 12V by an internal voltage reference is needed to provide correct gate drive to the power DMOS. The driving circuit is able to source and sink peak currents of around 0.5A to the gate of the DMOS transistor. A typical switching time of the current in the DMOS transistor is 50ns. Due to the fast commutation switching frequencies up to 200kHz are possible.

The PWM control loop consists of a sawtooth oscillator, error amplifier, comparator, latch and the output

stage. An error signal is produced by comparing the output voltage with the precise  $5.1V \pm 2\%$  on chip reference. This error signal is then compared with the sawtooth oscillator in order to generate fixed frequency pulse width modulated drive for the output stage. A PWM latch is included to eliminate multiple pulsing within a period even in noisy environments.

The gain and stability of the loop can be adjusted by an external RC network connected to the output of the error amplifier. A voltage feedforward control has been added to the oscillator, this maintains superior line regulation over a wide input voltage range. Closing the loop directly gives an output voltage of 5.1V, higher voltages are obtained by inserting a voltage divider.

At turn on, output overcurrents are prevented by the soft start function (fig. 5). The error amplifier is initially clamped by an external capacitor,  $C_{ss}$ , and allowed to rise linearly under the charge of an internal constant current source.

Output overload protection is provided by a current limit circuit. The load current is sensed by an internal metal resistor connected to a comparator. When the load current exceeds a preset threshold, the output of the comparator sets a flip flop which turns off the power DMOS. The next clock pulse, from an internal 40kHz oscillator, will reset the flip flop and the power DMOS will again conduct. This current protection method, ensures a constant current output when the system is overloaded or short circuited and limits the switching frequency, in this condition, to 40kHz. The Reset and Power fail diagram (fig. 7), generates an output signal when the supply voltage exceeds a threshold programmed by an external voltage divider. The reset signal, is generated with a delay time programmed by an external capacitor on the delay pin. When the supply voltage falls below the threshold or the output voltage goes below 5V, the reset output goes low immediately. The reset output is an open drain.

Fig. 7A shows the case when the supply voltage is higher than the threshold, but the output voltage is not yet 5V.

Fig. 7B shows the case when the output is 5.1V, but the supply voltage is not yet higher than the fixed threshold. The thermal protection disables circuit operation when the junction temperature reaches about  $150^{\circ}C$  and has a hysteresis to prevent unstable conditions.

Figure 4. Feedforward Waveform.

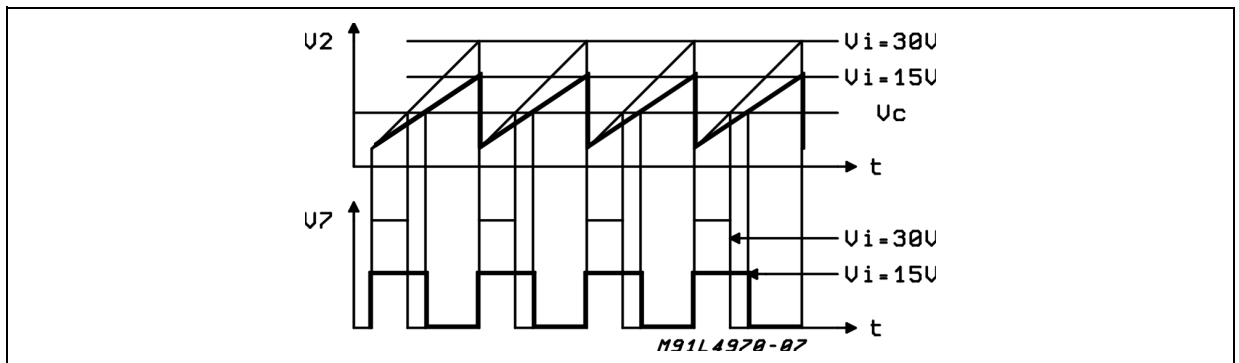

Figure 5. Soft Start Function.

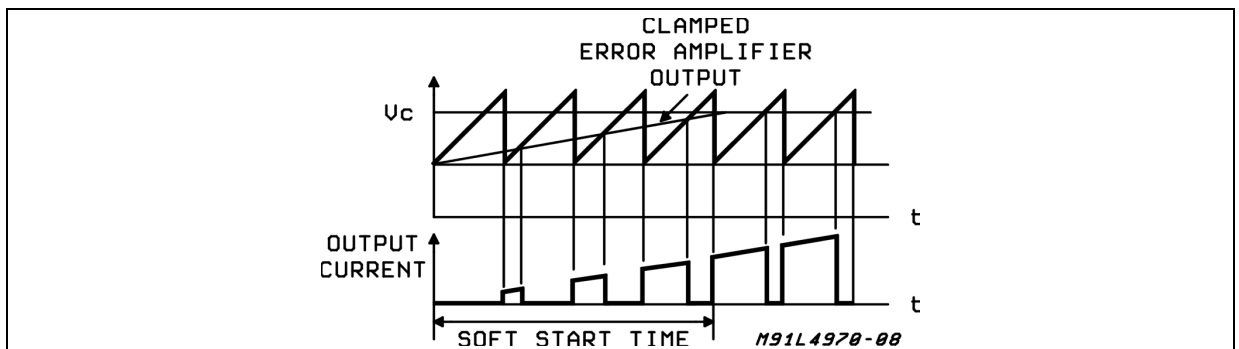

Figure 6. Limiting Current Function.

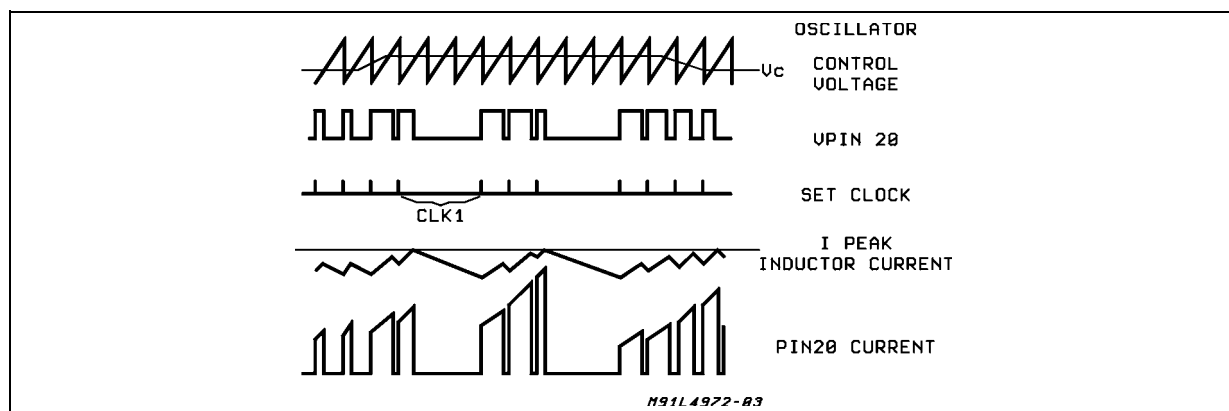
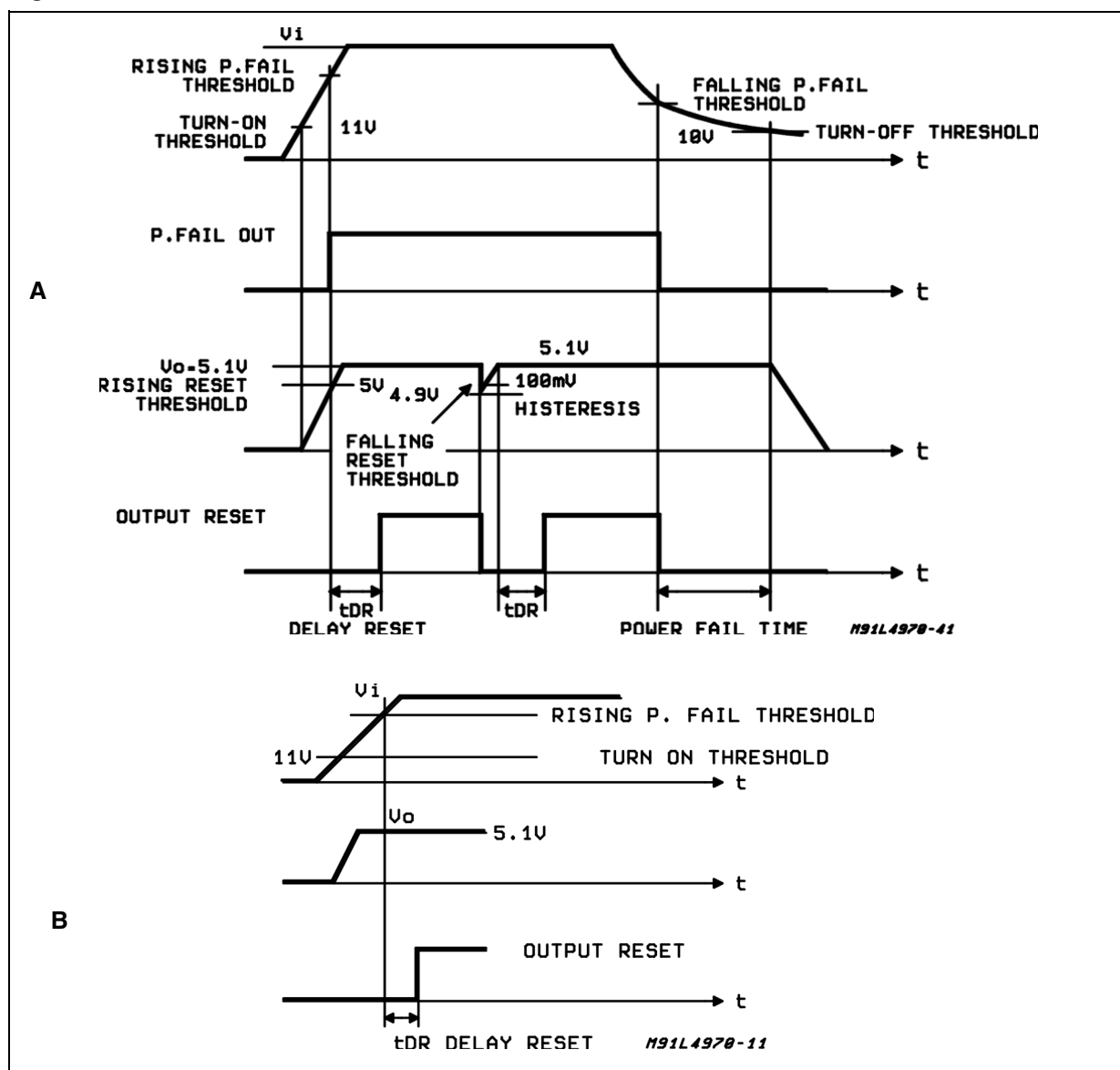

Figure 7. Reset and Power Fail Functions



## 4 Electrical Characteristics

**Table 5. Electrical Characteristics**

Refer to the test circuit,  $T_J = 25^\circ\text{C}$ ,  $V_i = 35\text{V}$ ,  $R_4 = 30\text{K}\Omega$ ,  $C_9 = 2.7\text{nF}$ ,  $f_{\text{SW}} = 100\text{KHz}$  typ, unless otherwise specified.

Symbol	Parameter	Test Condition	Min.	Typ.	Max.	Unit	Fig.
<b>DYNAMIC CHARACTERISTICS</b>							
$V_i$	Input Volt. Range (pin 11)	$V_o = V_{\text{ref}}$ to 40V $I_o = 2\text{A}$ (**)	15		50	V	8
$V_o$	Output Voltage	$V_i = 15\text{V}$ to 50V $I_o = 1\text{A}$ ; $V_o = V_{\text{ref}}$	5	5.1	5.2	V	8
$\Delta V_o$	Line Regulation	$V_i = 15\text{V}$ to 50V $I_o = 0.5\text{A}$ ; $V_o = V_{\text{ref}}$		12	30	mV	
$\Delta V_o$	Load Regulation	$V_o = V_{\text{ref}}$ $I_o = 0.5\text{A}$ to 2A		7	20	mV	
$V_d$	Dropout Voltage between Pin 11 and 20	$I_o = 2\text{A}$		0.25	0.4	V	
$I_{20L}$	Max Limiting Current	$V_i = 15\text{V}$ to 50V $V_o = V_{\text{ref}}$ to 40V	2.5	2.8	3.5	A	
$\eta$	Efficiency (*)	$I_o = 2\text{A}$ , $f = 100\text{KHz}$ $V_o = V_{\text{ref}}$ $V_o = 12\text{V}$	75	85 90		% %	
SVR	Supply Voltage Ripple Rejection	$V_i = 2V_{\text{RMS}}$ ; $I_o = 1\text{A}$ $f = 100\text{Hz}$ ; $V_o = V_{\text{ref}}$	56	60		dB	8
f	Switching Frequency		90	100	110	KHz	8
$\Delta f/\Delta V_i$	Voltage Stability of Switching Frequency	$V_i = 15\text{V}$ to 45V		2	6	%	8
$\Delta f/T_j$	Temperature Stability of Switching Frequency	$T_j = 0$ to $125^\circ\text{C}$		1		%	8
$f_{\text{max}}$	Maximum Operating Switching Frequency	$V_o = V_{\text{ref}}$ $R_4 = 15\text{K}\Omega$ $I_o = 2\text{A}$ $C_9 = 2.2\text{nF}$	200			KHz	8

(\*) Only for DIP version (\*\*) Pulse testing with a low duty cycle

<b>Vref SECTION (pin 13)</b>							
$V_{13}$	Reference Voltage		5	5.1	5.2	V	10
$\Delta V_{13}$	Line Regulation	$V_i = 15\text{V}$ to 50V		10	25	mV	10
$\Delta V_{13}$	Load Regulation	$I_{13} = 0$ to 1mA		20	40	mV	10
$\Delta V_{13}/\Delta T$	Average Temperature Coefficient Reference Voltage	$T_j = 0^\circ\text{C}$ to $125^\circ\text{C}$		0.4		mV/ $^\circ\text{C}$	10
$I_{13 \text{ short}}$	Short Circuit Current Limit	$V_{13} = 0$		70		mA	10
<b>VSTART SECTION (pin 15)</b>							
$V_{14}$	Reference Voltage		11.4	12	12.6	V	10
$\Delta V_{14}$	Line Regulation	$V_i = 15$ to 50V		0.6	1.4	V	10
$\Delta V_{14}$	Load Regulation	$I_{14} = 0$ to 1mA		50	200	mV	10
$I_{14 \text{ short}}$	Short Circuit Current Limit	$V_{15} = 0\text{V}$		80		mA	10
<b>DC CHARACTERISTICS</b>							
$V_{11\text{on}}$	Turn-on Threshold		10	11	12	V	12
$V_{11 \text{ Hyst}}$	Turn-off Hysteresys			1		V	12
$I_{11Q}$	Quiescent Current	$V_8 = 0$ ; $S_1 = D$		13	19	mA	12
$I_{110Q}$	Operating Supply Current	$V_8 = 0$ ; $S_1 = B$ ; $S_2 = B$		16	23	mA	12

**Table 5. Electrical Characteristics** (continued)

Refer to the test circuit,  $T_J = 25^\circ\text{C}$ ,  $V_i = 35\text{V}$ ,  $R_4 = 30\text{K}\Omega$ ,  $C_9 = 2.7\text{nF}$ ,  $f_{\text{SW}} = 100\text{KHz}$  typ, unless otherwise specified.

Symbol	Parameter	Test Condition	Min.	Typ.	Max.	Unit	Fig.
$I_{20L}$	Out Leak Current	$V_i = 55\text{V}$ ; $S_3 = A$ ; $V_8 = 0$			2	mA	12
<b>SOFT START (pin 8)</b>							
$I_8$	Soft Start Source Current	$V_8 = 3\text{V}$ ; $V_9 = 0\text{V}$	80	115	150	$\mu\text{A}$	13
$V_8$	Output Saturation Voltage	$I_8 = 20\text{mA}$ ; $V_{11} = 10\text{V}$ $I_8 = 200\mu\text{A}$ ; $V_{11} = 10\text{V}$			1 0.7	V V	13 13
<b>ERROR AMPLIFIER</b>							
$V_{7H}$	High Level Out Voltage	$I_7 = 100\mu\text{A}$ ; $S_1 = C$ ; $V_9 = 4.7\text{V}$	6			V	14
$V_{7L}$	Low Level Out Voltage	$I_7 = 100\mu\text{A}$ ; $S_1 = C$ ; $V_9 = 5.3\text{V}$			1.2	V	14
$I_{7H}$	Source Output Current	$V_7 = 1\text{V}$ ; $V_7 = 4.7\text{V}$	100	150		$\mu\text{A}$	14
$-I_{7L}$	Sink Output Current	$V_7 = 6\text{V}$ ; $V_9 = 5.3\text{V}$	100	150		$\mu\text{A}$	14
$I_9$	Input Bias Current	$S_1 = B$ ; $R_S = 10\text{K}\Omega$		0.4	3	$\mu\text{A}$	14
$G_V$	DC Open Loop Gain	$S_1 = A$ ; $R_S = 10\Omega$	60			dB	14
SVR	Supply Voltage Rejection	$15 < V_i < 50\text{V}$	60	80		dB	14
$V_{OS}$	Input Offset Voltage	$R_S = 50\Omega$ $S_1 = A$		2	10	mV	14
<b>RAMP GENERATOR (pin 18)</b>							
$V_{18}$	Ramp Valley	$S_1 = B$ ; $S_2 = B$	1.2	1.5		V	12
$V_{18}$	Ramp Peak	$S_1 = B$ ; $S_2 = B$ $V_i = 15\text{V}$ $V_i = 45\text{V}$		2.5 5.5		V V	12 12
$I_{18}$	Min. Ramp Current	$S_1 = A$ ; $I_{17} = 100\mu\text{A}$		270	300	$\mu\text{A}$	12
$I_{18}$	Max. Ramp Current	$S_1 = A$ ; $I_{17} = 1\text{mA}$	2.4	2.7		mA	12
<b>SYNC FUNCTION (pin 10)</b>							
$V_{10}$	Low Input Voltage	$V_i = 15\text{V}$ to $50\text{V}$ ; $V_8 = 0$ ; $S_1 = B$ ; $S_2 = B$ ; $S_4 = B$	-0.3		0.9	V	12
$V_{10}$	High Input voltage	$V_8 = 0$ ; $S_1 = B$ ; $S_2 = B$ ; $S_4 = B$	2.5		5.5	V	12
$I_{10L}$	Sync Input Current with Low Input Voltage	$V_{10} = V_{18} = 0.9\text{V}$ ; $S_4 = B$ ; $S_1 = B$ ; $S_2 = B$			0.4	mA	12
$I_{10H}$	Input Current with High Input Voltage	$V_{10} = 2.5\text{V}$			1.5	mA	12
$V_{10}$	Output Amplitude		4	5		V	-
$t_w$	Output Pulse Width	$V_{\text{thr}} = 2.5\text{V}$	0.3	0.5	0.8	$\mu\text{s}$	-
<b>RESET AND POWER FAIL FUNCTIONS</b>							
$V_{9R}$	Rising Thershold Voltage (pin 9)	$V_i = 15$ to $50\text{V}$ $V_4 = 5.3\text{V}$	$V_{\text{ref}}$ -130	$V_{\text{ref}}$ -100	$V_{\text{ref}}$ -80	V mV	15
$V_{9F}$	Falling Thershold Voltage (pin 9)	$V_i = 15$ to $50\text{V}$ $V_4 = 5.3\text{V}$	4.77	$V_{\text{ref}}$ -200	$V_{\text{ref}}$ -160	V mV	15
$V_{2H}$	Delay High Threshold Volt.	$V_i = 15$ to $50\text{V}$ $V_4 = 5.3\text{V}$ ; $V_9 = V_{13}$	4.95	5.1	5.25	V	15
$V_{2L}$	Delay Low Threshold Volt.	$V_i = 15$ to $50\text{V}$ ; $V_4 = 4.7\text{V}$ ; $V_9 = V_{13}$	1	1.1	1.2	V	15
$I_{2SO}$	Delay Source Current	$V_4 = 5.3\text{V}$ ; $V_2 = 3\text{V}$	30	60	80	$\mu\text{A}$	15
$I_{2SI}$	Delay Source Sink Current	$V_4 = 4.7\text{V}$ ; $V_2 = 3\text{V}$	10			mA	15
$V_{3S}$	Output Saturation Voltage	$I_3 = 15\text{mA}$ ; $S_1 = B$ $V_4 = 4.7\text{V}$			0.4	V	15
$I_3$	Output Leak Current	$V_3 = 50\text{V}$ ; $S_1 = A$			100	$\mu\text{A}$	15

**Table 5. Electrical Characteristics** (continued)

Refer to the test circuit,  $T_J = 25^\circ\text{C}$ ,  $V_i = 35\text{V}$ ,  $R_4 = 30\text{K}\Omega$ ,  $C_9 = 2.7\text{nF}$ ,  $f_{\text{sw}} = 100\text{KHz}$  typ, unless otherwise specified.

Symbol	Parameter	Test Condition	Min.	Typ.	Max.	Unit	Fig.
$V_{4R}$	Rising Threshold Voltage	$V_9 = V_{13}$	4.95	5.1	5.25	V	15
$V_{4H}$	Hysteresis		0.4	0.5	0.6	V	15
$I_4$	Input Bias Current			1	3	$\mu\text{A}$	15

**Figure 8.**

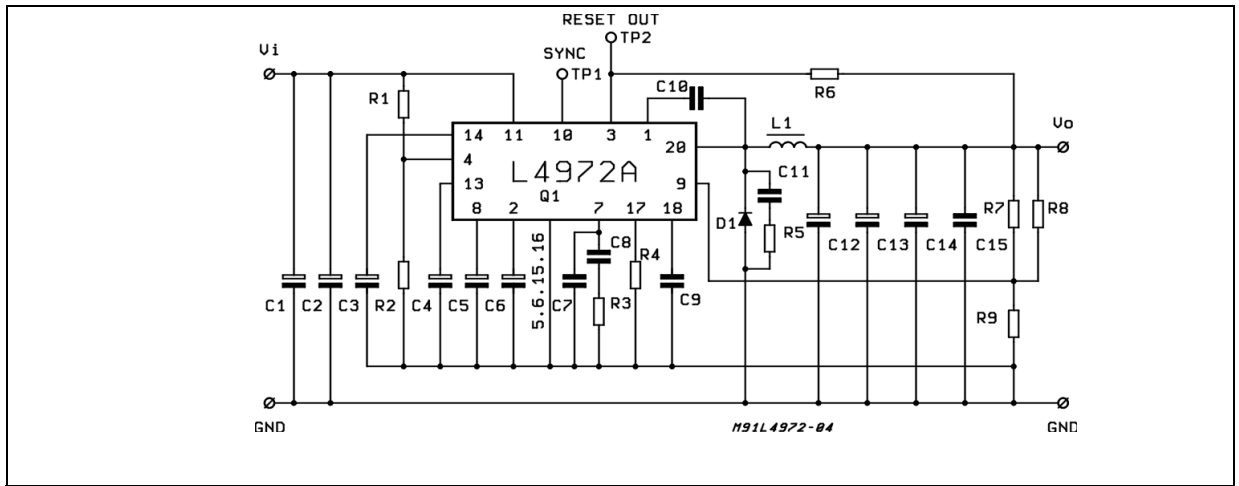

**TYPICAL PERFORMANCES (using evaluation board) :**

$\eta = 83\%$  ( $V_i = 35\text{V}$  ;  $V_o = V_{\text{REF}}$  ;  $I_o = 2\text{A}$  ;  $f_{\text{sw}} = 100\text{KHz}$ )

$V_o$  RIPPLE = 30mV (at 1A)

Line regulation = 12mV ( $V_i = 15$  to 50V)

Load regulation = 7mV ( $I_o = 0.5$  to 2A)

for component values Refer to the fig. 8 (Part list).

**Figure 9. Component Layout of fig. 8. Evaluation Board Available (only for DIP version)**

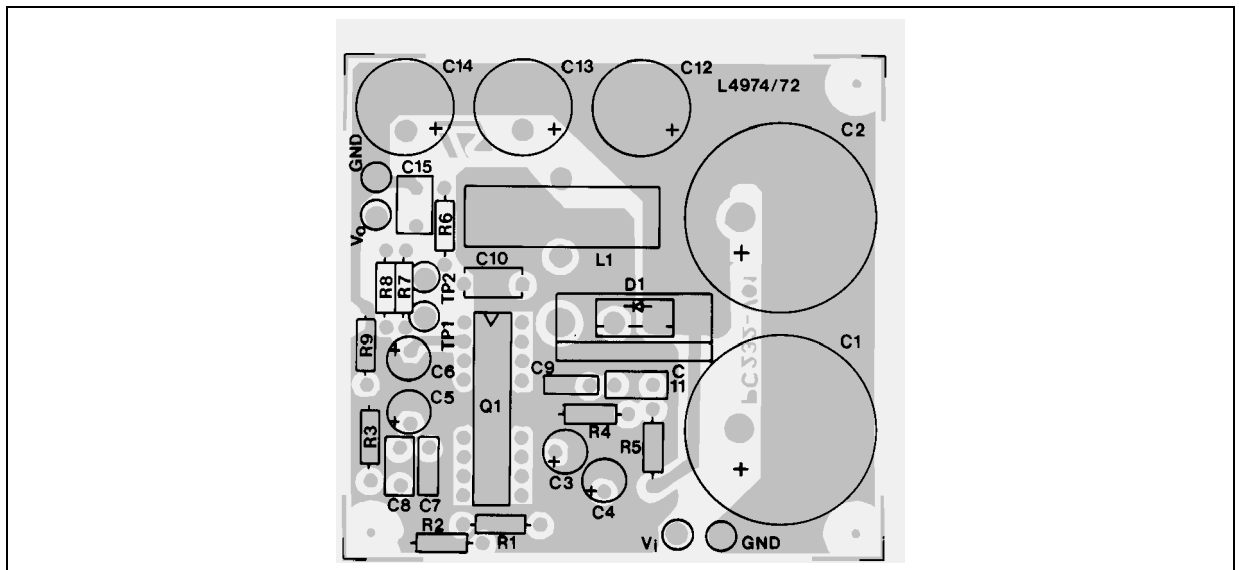



**PART LIST**R1 = 30K $\Omega$ R2 = 10K $\Omega$ R3 = 15K $\Omega$ R4 = 30K $\Omega$ R5 = 22 $\Omega$ R6 = 4.7K $\Omega$ 

R7 = see table 6

R8 = OPTION

R9 = 4.7K $\Omega$ 

\* C1 = C2 = 1000mF 63V EYF (ROE)

C3 = C4 = C5 = C6 = 2,2 $\mu$ F 50V

C7 = 390pF Film

C8 = 22nF MKT 1837 (ERO)

C9 = 2.7nF KP 1830 (ERO)

C10 = 0.33 $\mu$ F Film

C11 = 1nF

\*\* C12 = C13 = C14 = 100 $\mu$ F 40V EKR (ROE)C15 = 1 $\mu$ F Film

D1 = STPS5L60

L1 = 150 $\mu$ H

core 58310 MAGNETICS

45 TURNS 0.91mm (AWG 19)

COGEMA 949181

\* 2 capacitors in parallel to increase input RMS current capability.

\*\* 3 capacitors in parallel to reduce total output ESR.

**Table 6.**

<b>V<sub>0</sub></b>	<b>R<sub>9</sub></b>	<b>R<sub>7</sub></b>
12V	4.7k $\Omega$	6.2k $\Omega$
15V	4.7k $\Omega$	9.1k $\Omega$
18V	4.7k $\Omega$	12 $\Omega$
24V	4.7k $\Omega$	18 $\Omega$

Note:

In the Test and Application Circuit for L4972D are not mounted C2, C14 and R8.

**Table 7. Suggested Bootstrap Capacitors**

<b>Operating Frequency</b>	<b>Bootstrap Cap.c10</b>
f = 20KHz	$\geq$ 680nF
f = 50KHz	$\geq$ 470nF
f = 100KHz	$\geq$ 330nF
f = 200KHz	$\geq$ 220nF
f = 500KHz	$\geq$ 100nF

Figure 10. P.C. Board and Component Layout of the Circuit of Fig. 8.

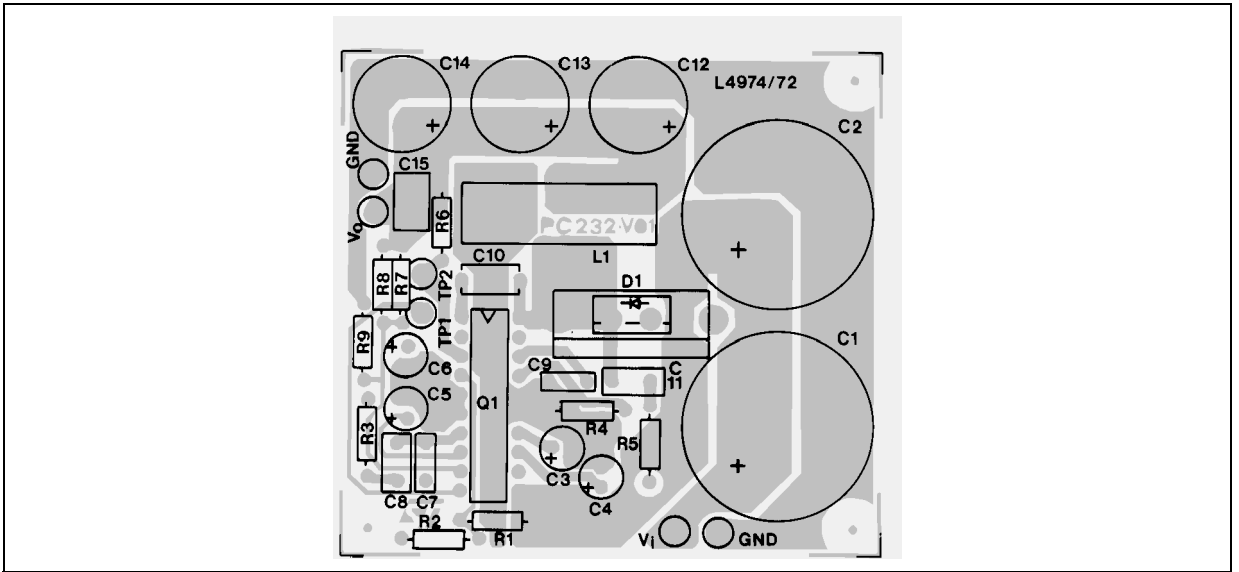

Figure 11. DC Test Circuits

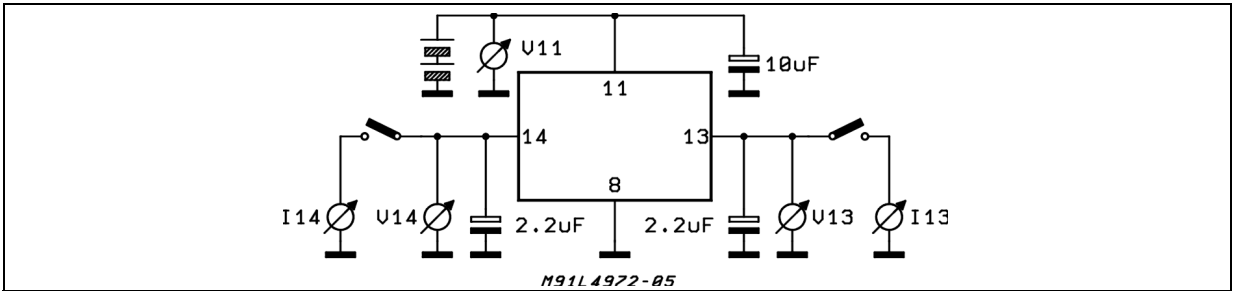

Figure 12.

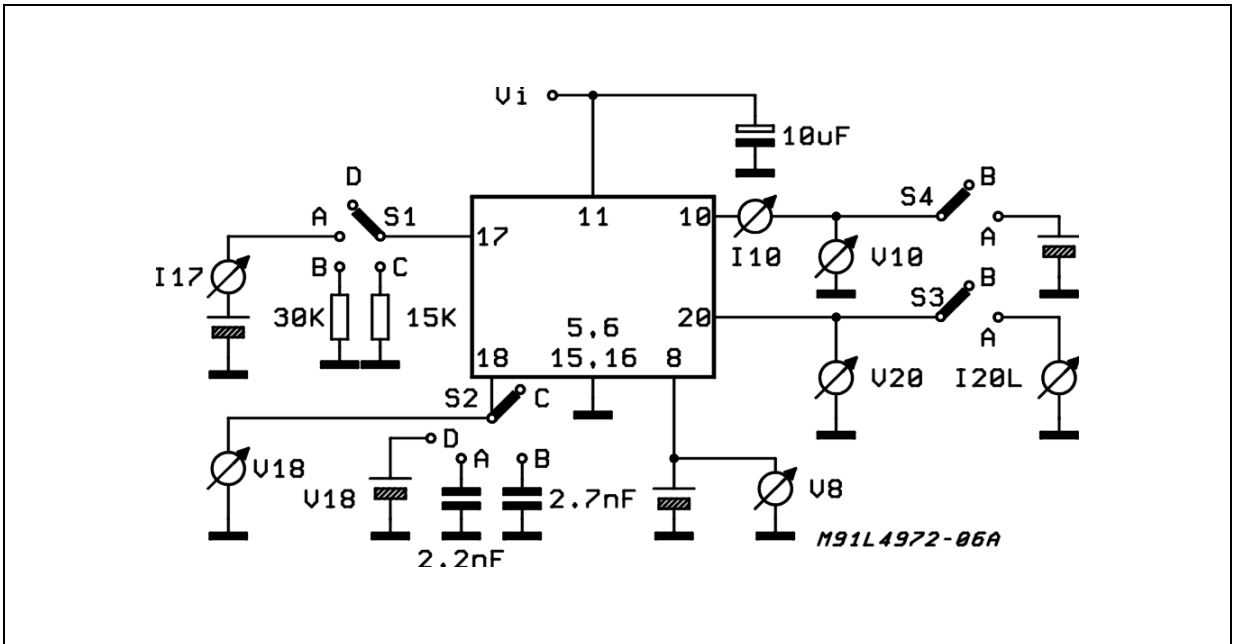

Figure 13.

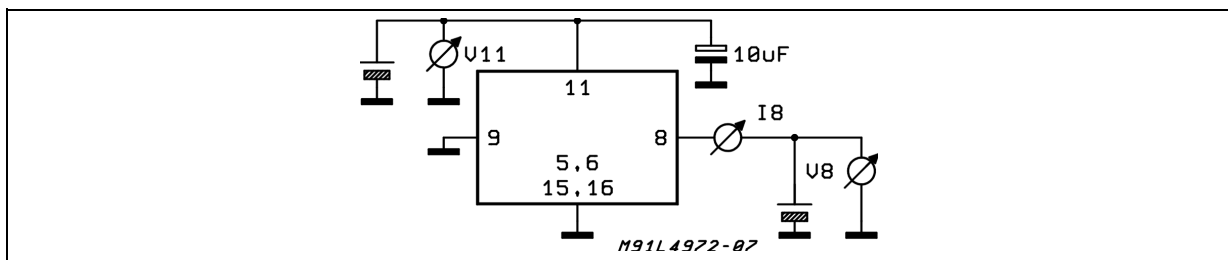

Figure 14.

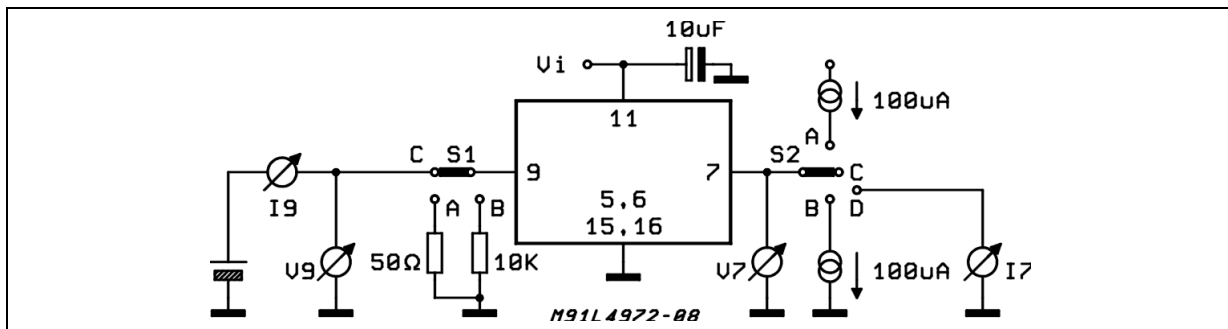

Figure 15.

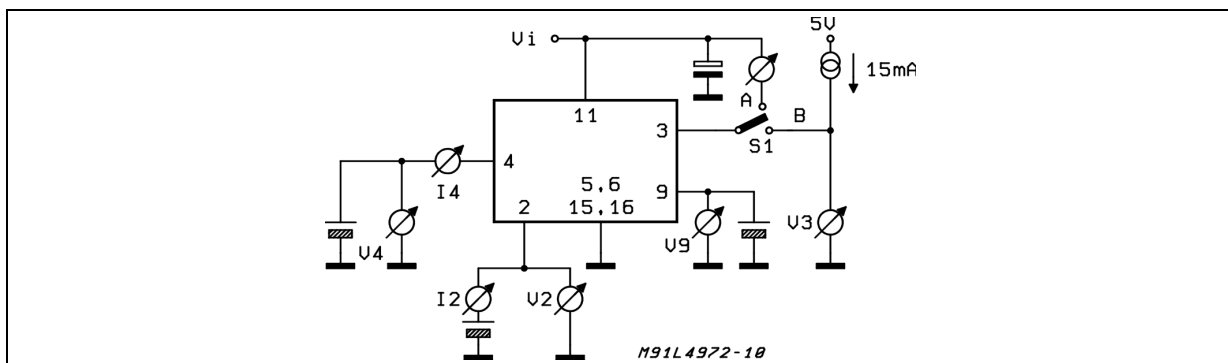

Figure 16. Quiescent Drain Current vs. Supply Voltage (0% duty cycle - see fig. 12).

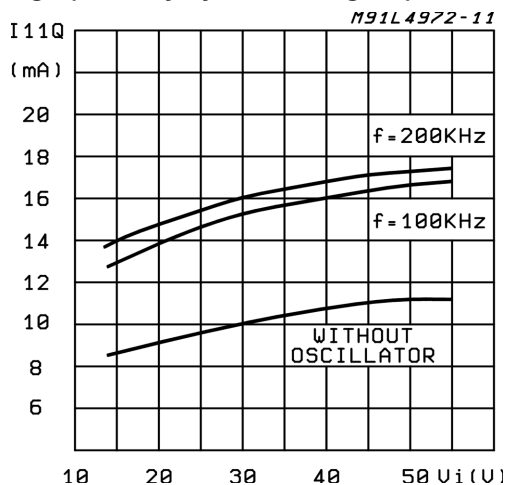

Figure 17. Quiescent Drain Current vs. Junction Temperature (0% duty cycle).

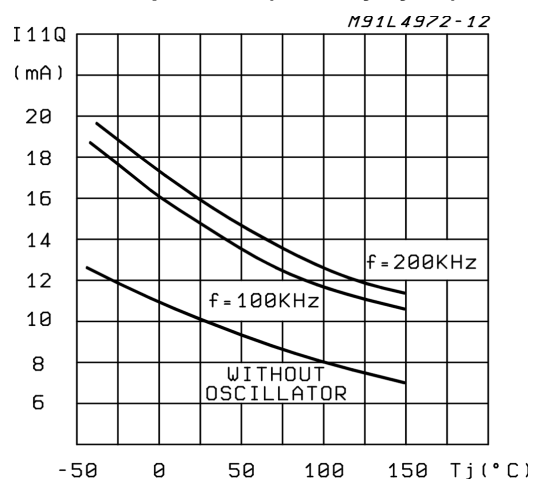

Figure 18. Quiescent Drain Current vs. Duty Cycle.

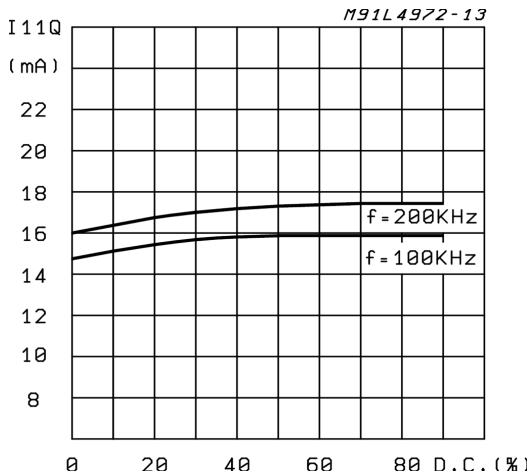

Figure 21. Reference Voltage (pin 14) vs. Vi (see fig. 11).

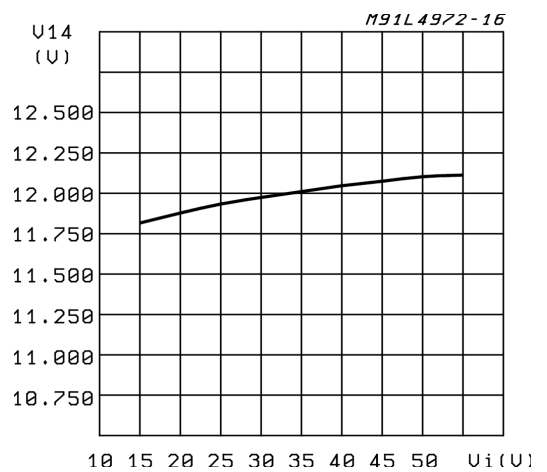

Figure 19. Reference Voltage (pin 13) vs. Vi (see fig. 11).

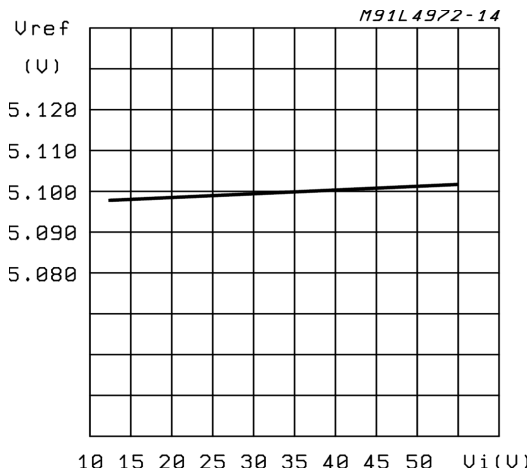

Figure 22. Reference Voltage (pin 14) vs. Junction Temperature (see fig. 11).

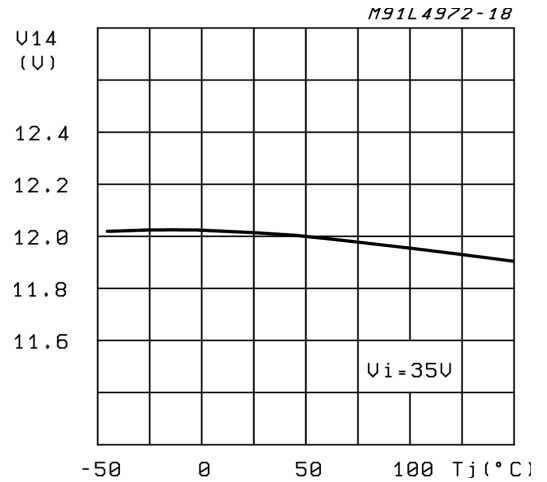

Figure 20. Reference Voltage (pin 13) vs. Junction Temperature (see fig. 11).

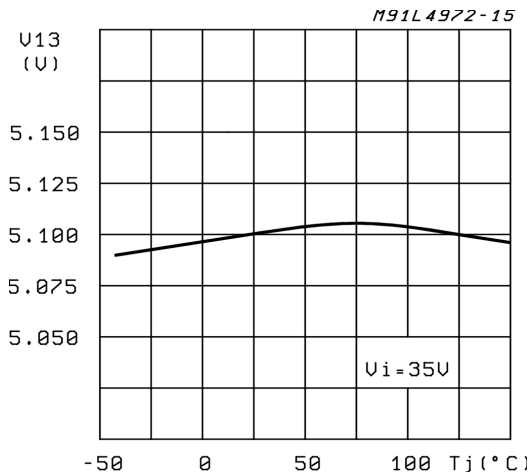

Figure 23. : Ref. Voltage 5.1V (pin 13) Supply Voltage Ripple Rejection vs. Frequency

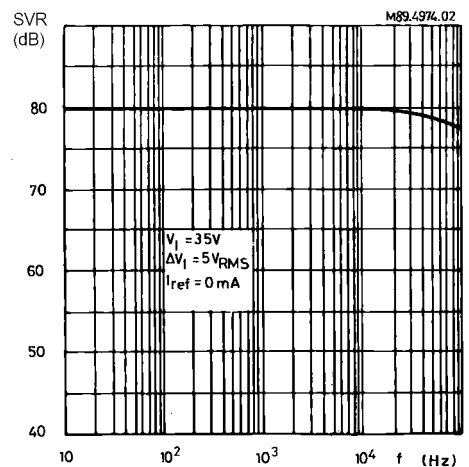

Figure 24. Switching Frequency vs. Input Voltage (see fig. 8).

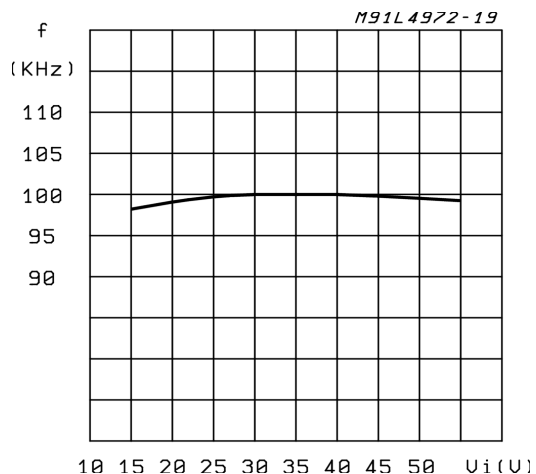

Figure 27. Maximum Duty Cycle vs. Frequency.

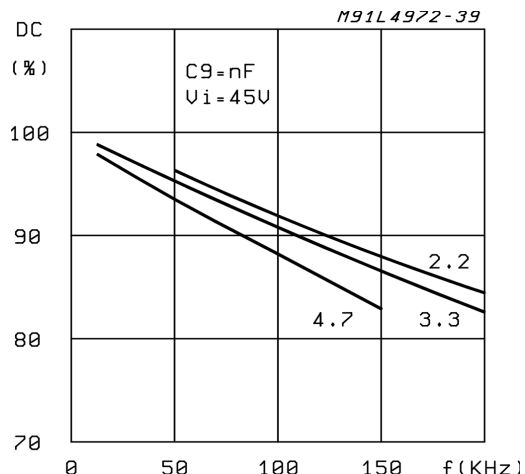

Figure 25. Switching Frequency vs. Junction Temperature (see fig. 8).

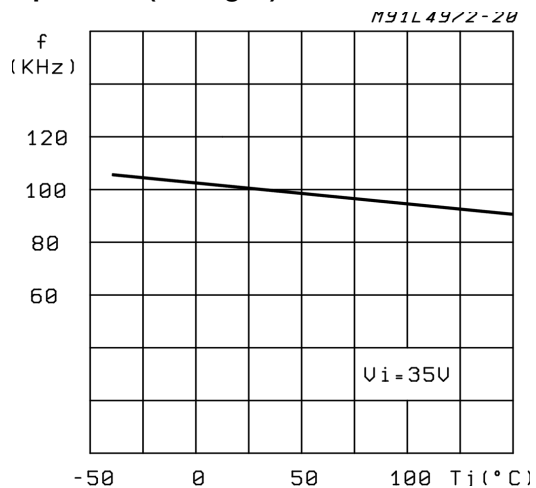

Figure 28. Supply Voltage Ripple Rejection vs. Frequency (see fig. 8).

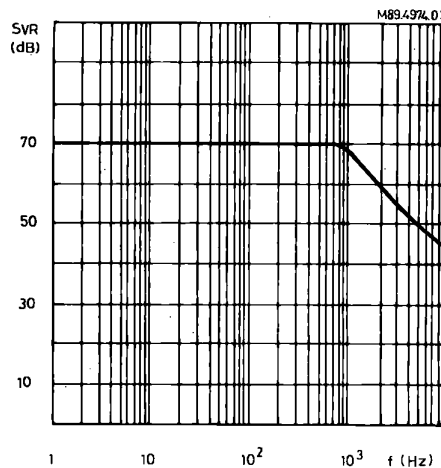

Figure 26. Switching Frequency vs. R4 (see fig.8).

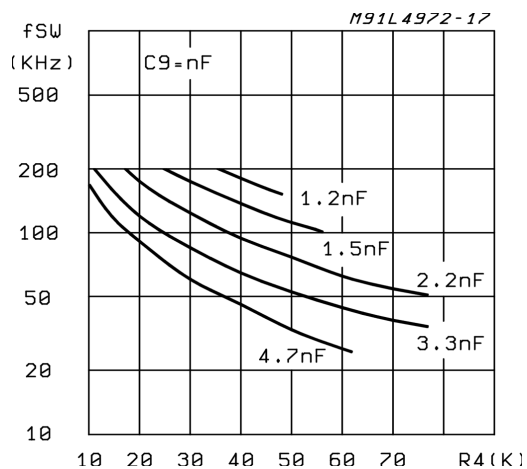

Figure 29. Efficiency vs. Output Voltage.

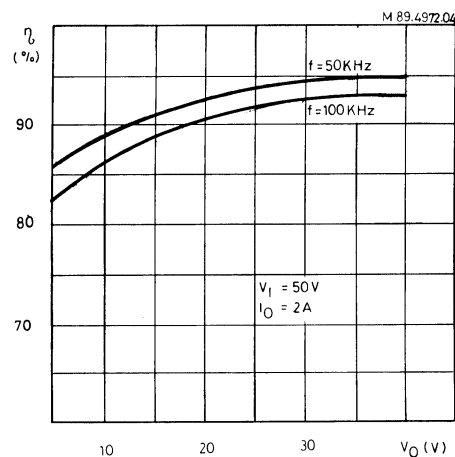

Figure 30. Line Transient Response (see fig. 8).

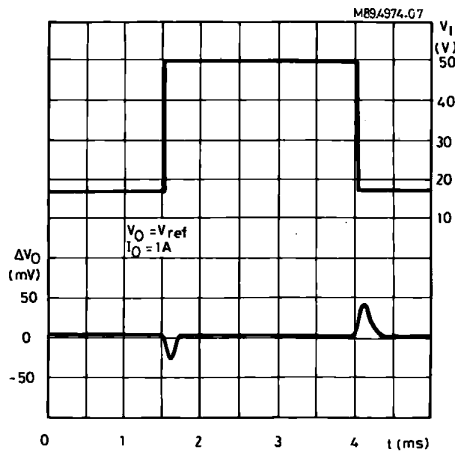

Figure 31. Line Transient Response (see fig. 8).

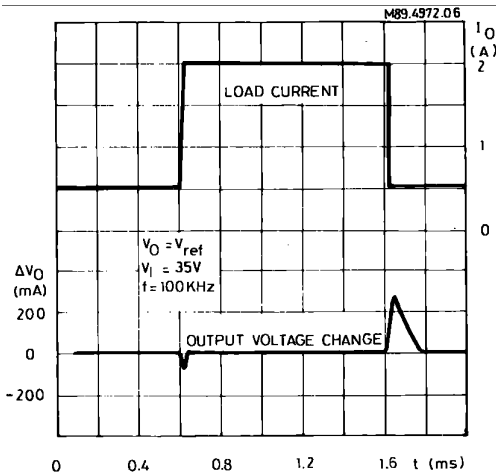

Figure 32. Dropout Voltage between Pin 11 and Pin 20 vs. Current at Pin 20.

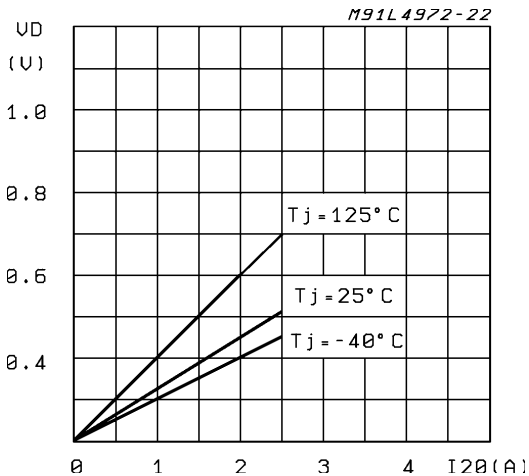

Figure 33. Dropout Voltage between Pin 11 and Pin 20 vs. Junction Temperature.

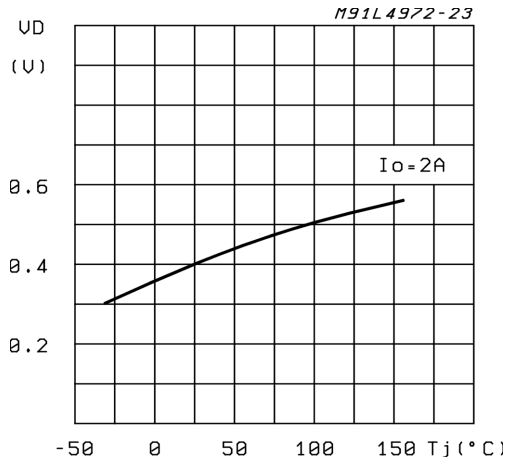

Figure 34. Power Dissipation (device only) vs. Input Voltage.

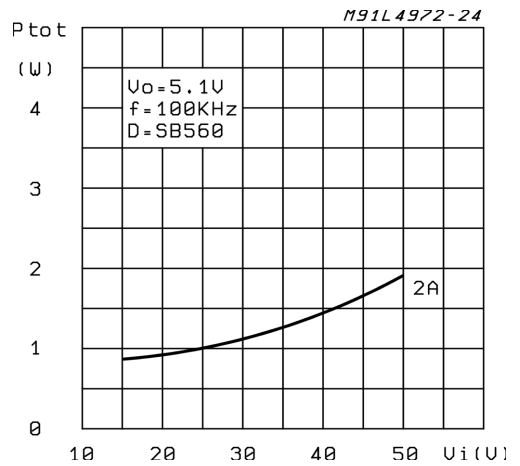

Figure 35. Power Dissipation (device only) vs. Input Voltage.

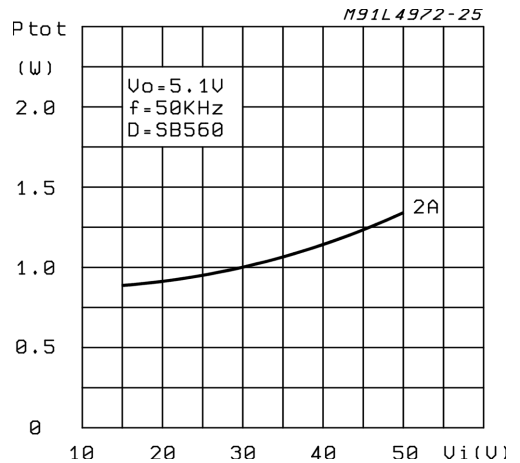

Figure 36. Power Dissipation (device only) vs. Output Voltage.

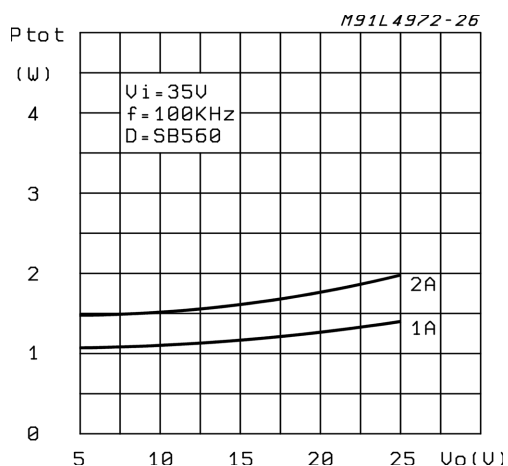

Figure 39. Power Dissipation (device only) vs. Output Current

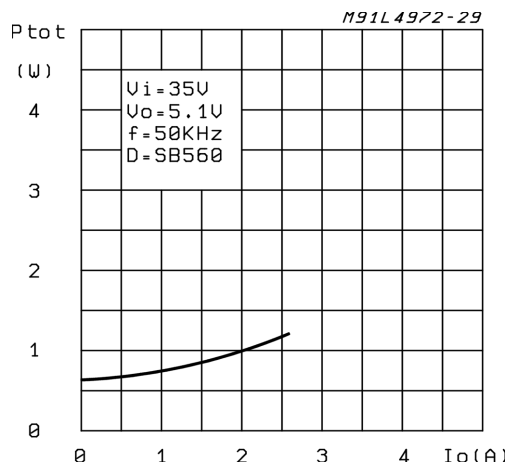

Figure 37. Power Dissipation (device only) vs. Output Voltage

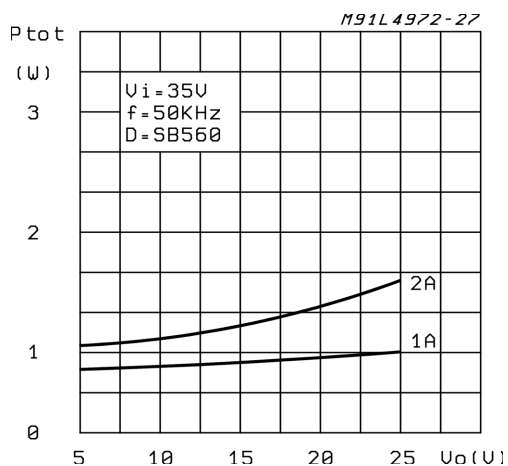

Figure 40. Efficiency vs. Output Current

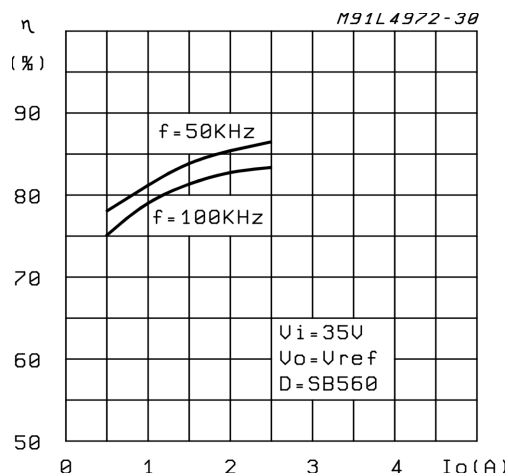

Figure 38. Power Dissipation (device only) vs. Output Current

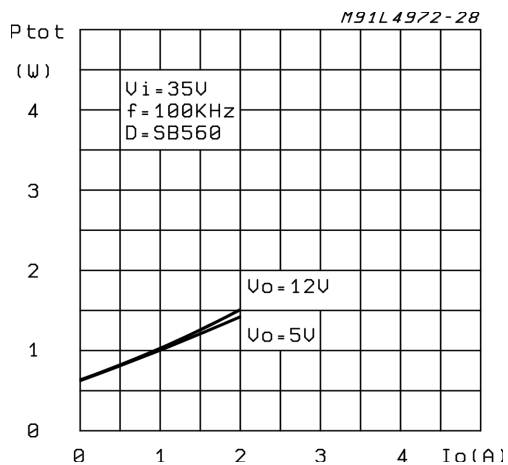

Figure 41. Test PCB Thermal Characteristic.

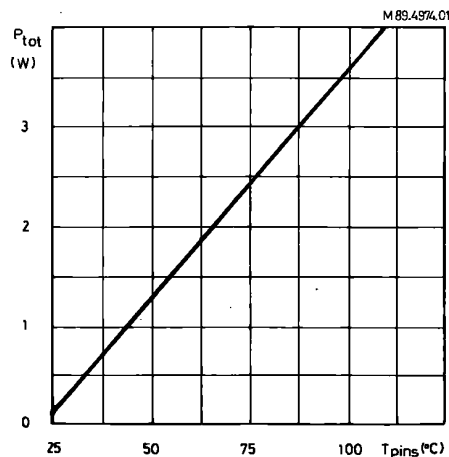

Figure 42. Rth j-amb vs. Area on Board Heatsink (DIP 16+2+2)

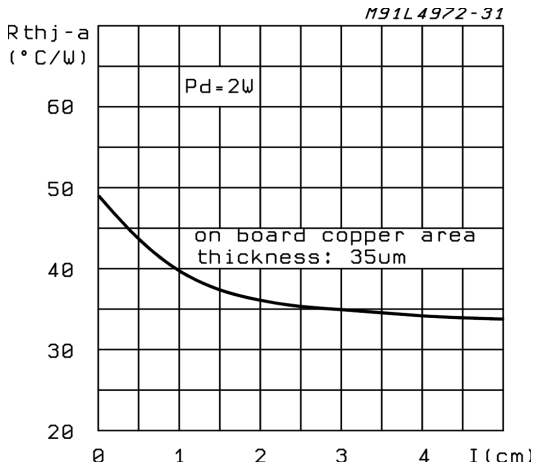

Figure 45. Maximum Allowable Power Dissipation vs. Ambient Temperature (SO20)

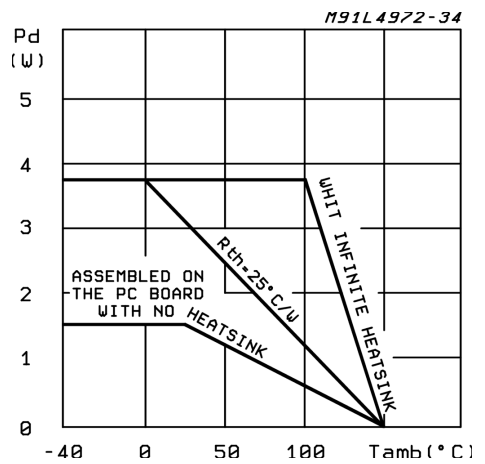

Figure 43. Rth j-amb vs. Area on Board Heatsink (SO20)

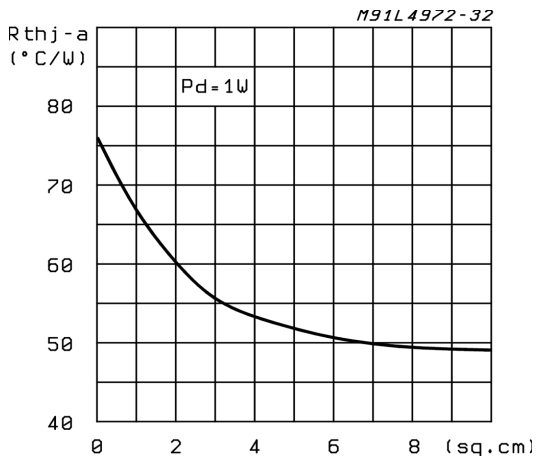

Figure 46. Open Loop Frequency and Phase of Error Amplifier (see fig. 14).

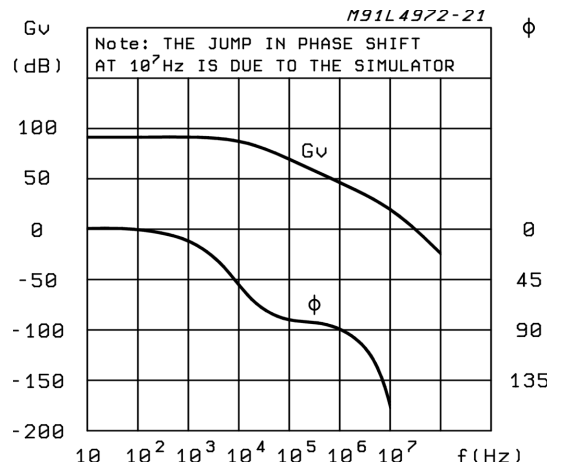

Figure 44. Maximum Allowable Power Dissipation vs. Tamb (Powerdip)

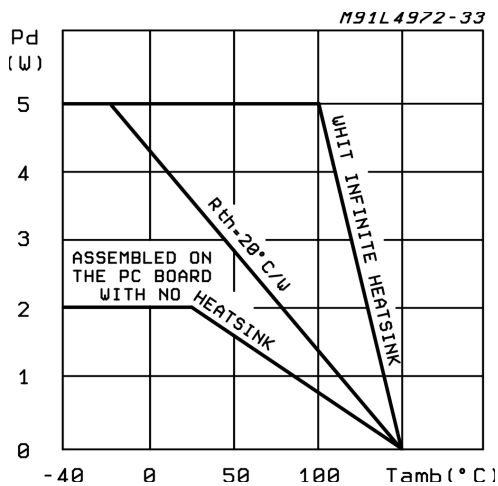



Figure 47. 2A – 5.1V Low Cost Application Circuit.

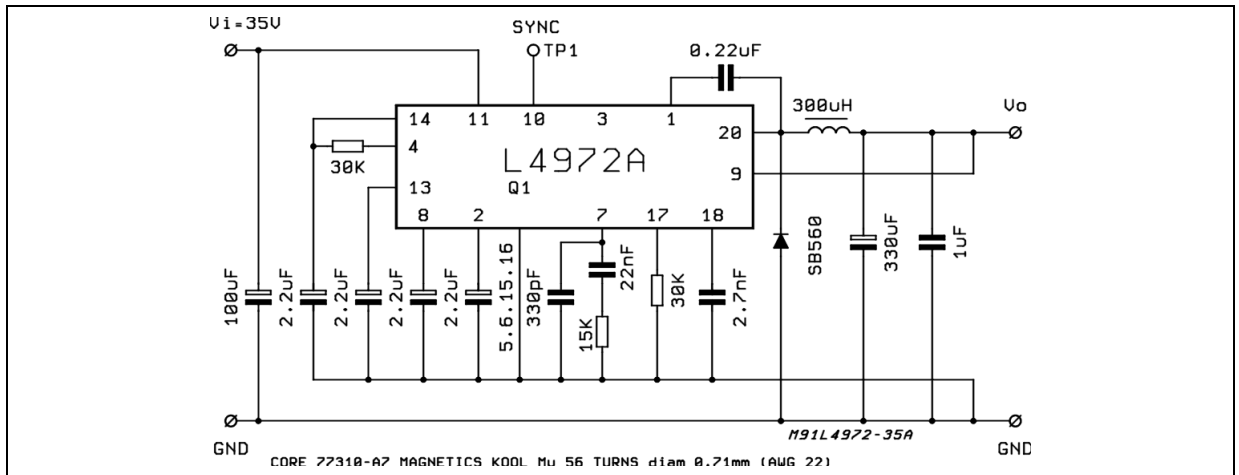

Figure 48. A 5.1V/12V Multiple Supply. Note the Synchronization between the L4972A and L4970A.

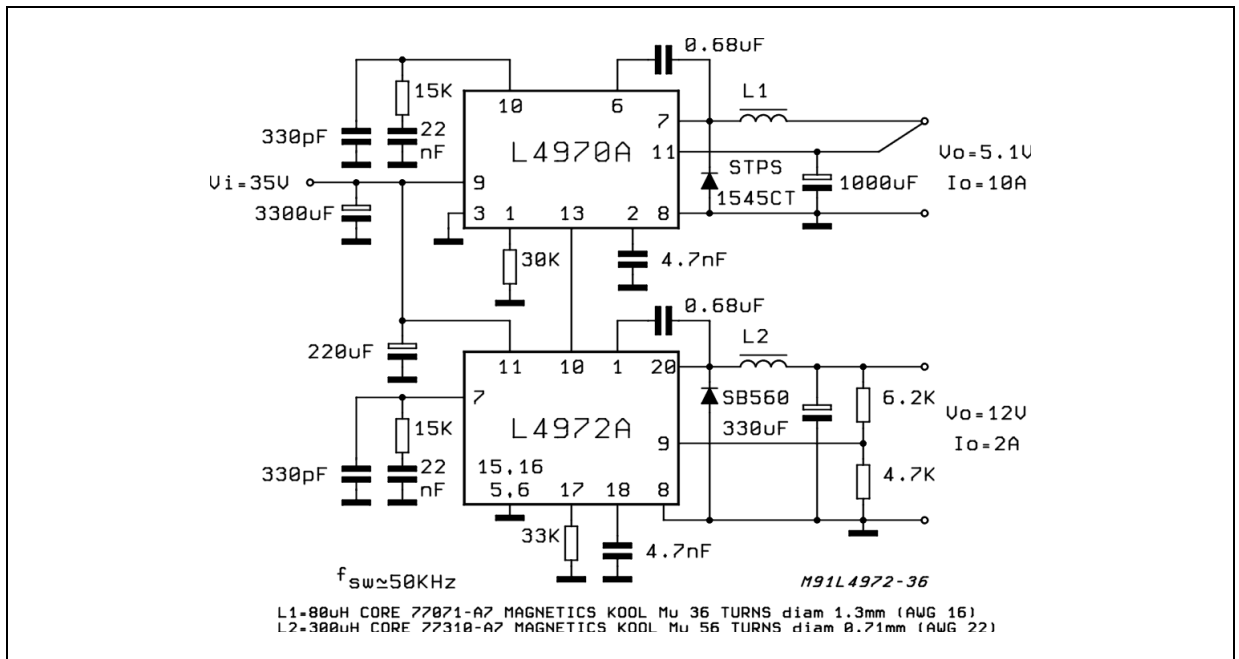

Figure 49. L4972A's Sync. Example.

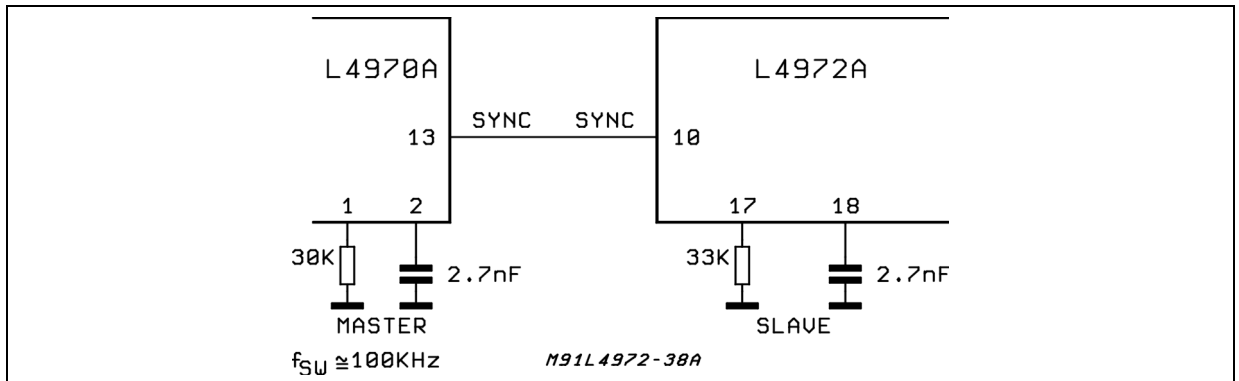
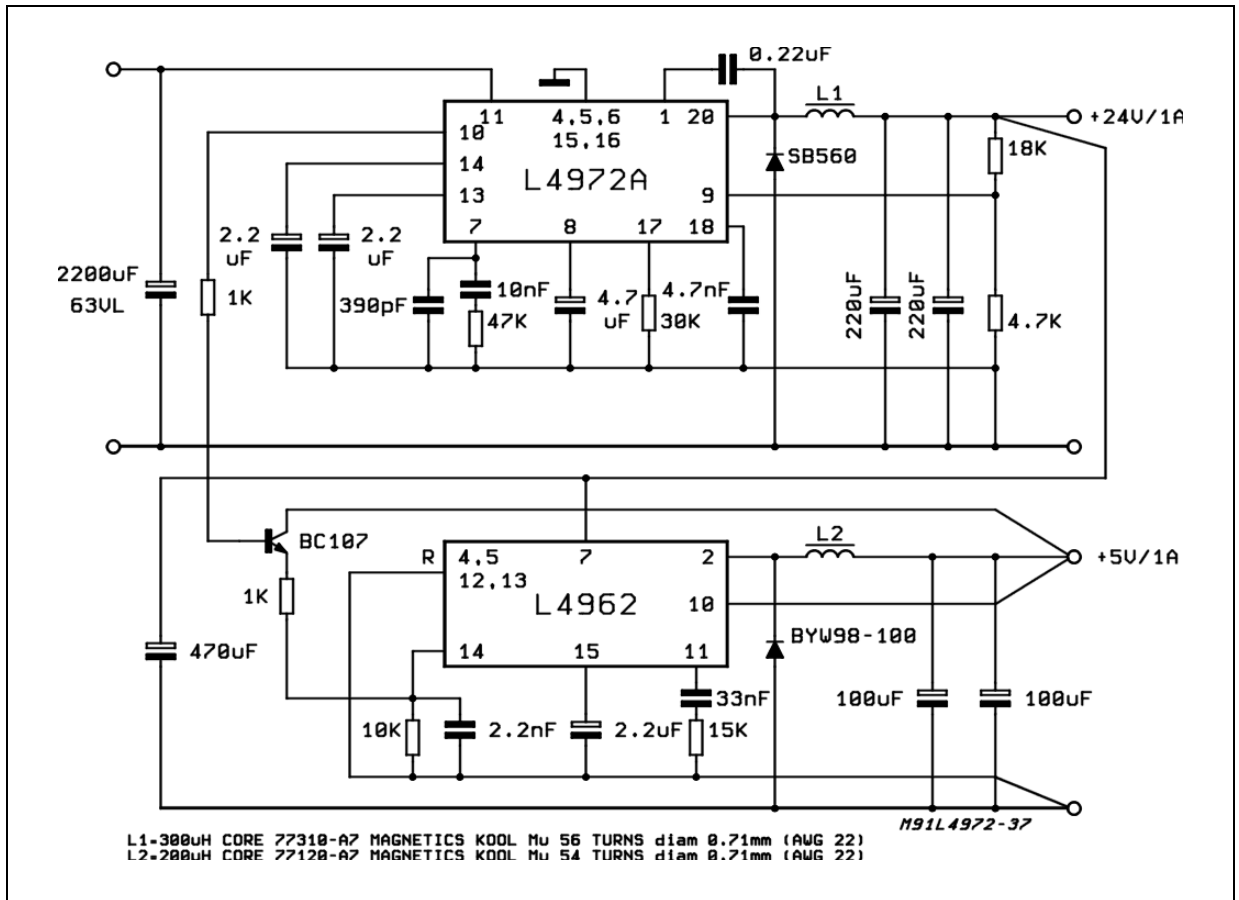

Figure 50. 1A/24V Multiple Supply. Note the synchronization between the L4972A and L4962



## 5 Package Information

Figure 51. PowerDIP20 Mechanical Data & Package Dimensions

DIM.	mm			inch		
	MIN.	TYP.	MAX.	MIN.	TYP.	MAX.
a1	0.51			0.020		
B	0.85		1.40	0.033		0.055
b		0.50			0.020	
b1	0.38		0.50	0.015		0.020
D			24.80			0.976
E		8.80			0.346	
e		2.54			0.100	
e3		22.86			0.900	
F			7.10			0.280
I			5.10			0.201
L		3.30			0.130	
Z			1.27			0.050

### OUTLINE AND MECHANICAL DATA

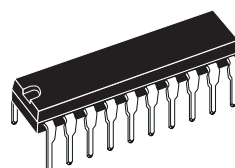

### Powerdip 20

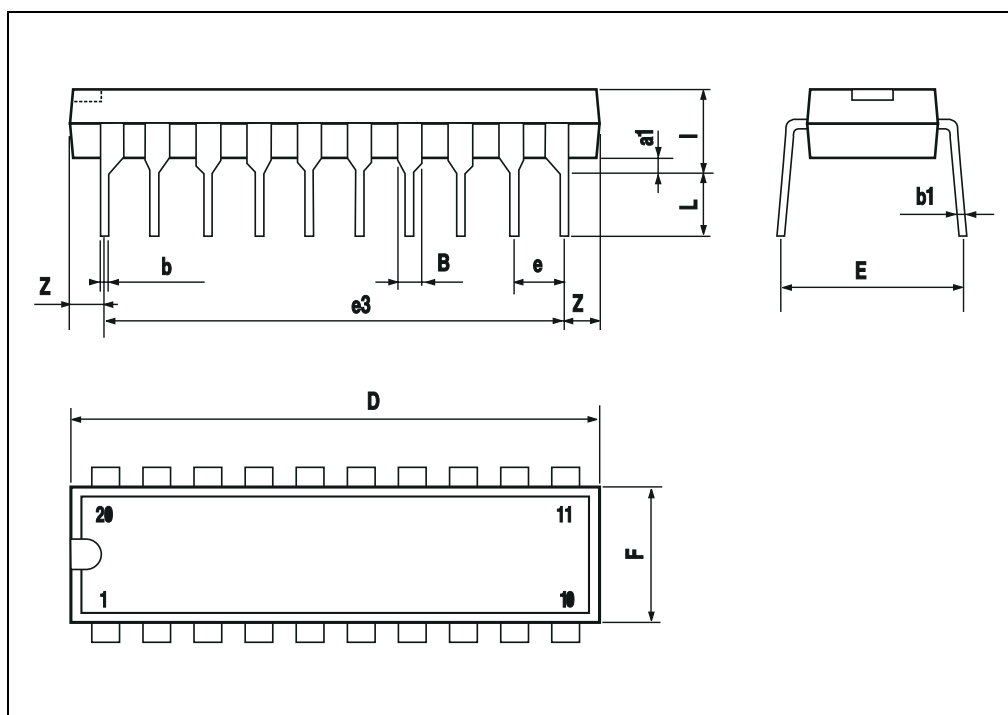
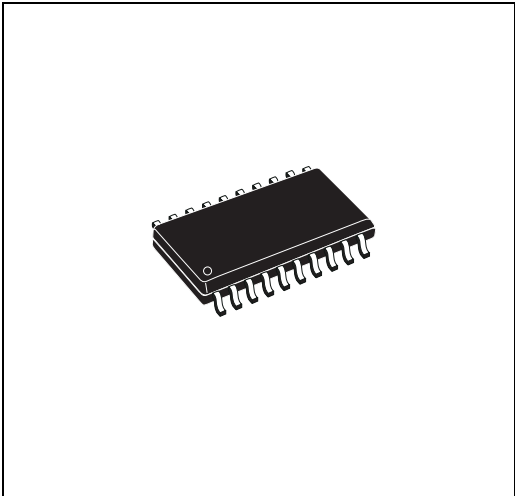

Figure 52. SO20 Mechanical Data & Package Dimensions

DIM.	mm			inch		
	MIN.	TYP.	MAX.	MIN.	TYP.	MAX.
A	2.35		2.65	0.093		0.104
A1	0.10		0.30	0.004		0.012
B	0.33		0.51	0.013		0.200
C	0.23		0.32	0.009		0.013
D (1)	12.60		13.00	0.496		0.512
E	7.40		7.60	0.291		0.299
e		1.27			0.050	
H	10.0		10.65	0.394		0.419
h	0.25		0.75	0.010		0.030
L	0.40		1.27	0.016		0.050
k	0° (min.), 8° (max.)					
ddd			0.10			0.004

(1) "D" dimension does not include mold flash, protusions or gate burrs. Mold flash, protusions or gate burrs shall not exceed 0.15mm per side.

**OUTLINE AND MECHANICAL DATA**



**SO20**

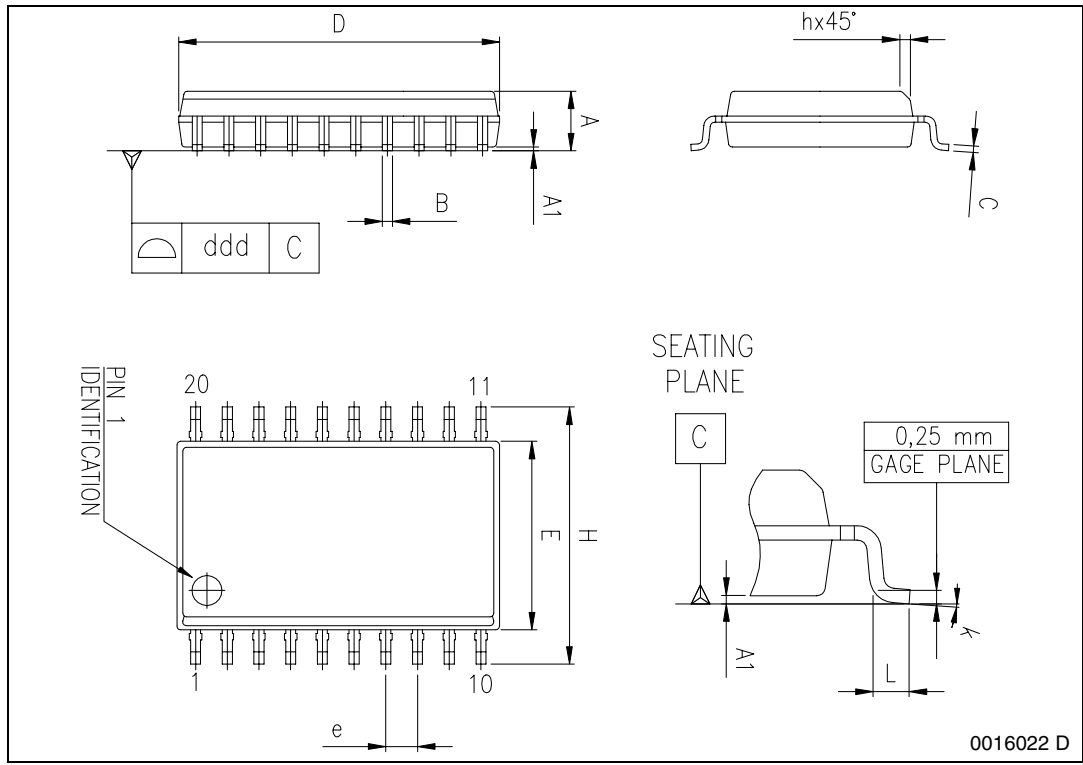

0016022 D

## 6 Revision History

**Table 8. Revision History**

Date	Revision	Description of Changes
June 2000	2	First Issue
May 2005	3	Modified look & feel layout. Changed the name of D1 in the Part list to page 9/22.

Information furnished is believed to be accurate and reliable. However, STMicroelectronics assumes no responsibility for the consequences of use of such information nor for any infringement of patents or other rights of third parties which may result from its use. No license is granted by implication or otherwise under any patent or patent rights of STMicroelectronics. Specifications mentioned in this publication are subject to change without notice. This publication supersedes and replaces all information previously supplied. STMicroelectronics products are not authorized for use as critical components in life support devices or systems without express written approval of STMicroelectronics.

The ST logo is a registered trademark of STMicroelectronics.  
All other names are the property of their respective owners

© 2005 STMicroelectronics - All rights reserved

STMicroelectronics group of companies

Australia - Belgium - Brazil - Canada - China - Czech Republic - Finland - France - Germany - Hong Kong - India - Israel - Italy - Japan -  
Malaysia - Malta - Morocco - Singapore - Spain - Sweden - Switzerland - United Kingdom - United States of America

[www.st.com](http://www.st.com)