

3A Switching Charger, 2.4A Boost and 3 LED-indicators for battery level, charge/discharge status in One ESOP8 with Single Inductor

DESCRIPTION

ETA9742 is a switching Li-Ion battery charger capable of delivering up to 3A of charging current to the battery and also capable of delivering up to 5V/2.4A in boost operation, with high efficiency in both charging mode and boost mode. It also includes a fuel gauge system for power indication. For charging, it uses a proprietary control scheme that eliminates the current sense resistor for conventional constant current control, maximizing efficiency, reducing charging time and reducing costs. It can also output a 5V voltage in the reversed direction by boosting from the battery. It only needs a single inductor to provide power bi-directionally with a proprietary automatic mode detect and switch scheme. ETA9742 is an ideal all-in-one solution for battery charging and discharge applications, such as power banks, smart phones, and tablets with only one USB port that can be used for charging battery function.

ETA9742 is suitable for charging a 4.2V Li-ion battery. And ETA9742 is in ESOP8 package.

FEATURES

- ◆ Bi-Directional Power conversion with Single Inductor
- ◆ Automatic Mode Switching
- ◆ Switching Charger
- ◆ 5V Synchronous Boost
- ◆ Up to 96% Efficiency
- ◆ Up to 3A Max charging current and 2.4A discharging
- ◆ No-Battery detection
- ◆ No External Sense resistor
- ◆ LEDs for battery level indication and charge/discharge status indication

APPLICATIONS

- ◆ Tablet, MID
- ◆ Smart Phone
- ◆ Power Bank

TYPICAL APPLICATION

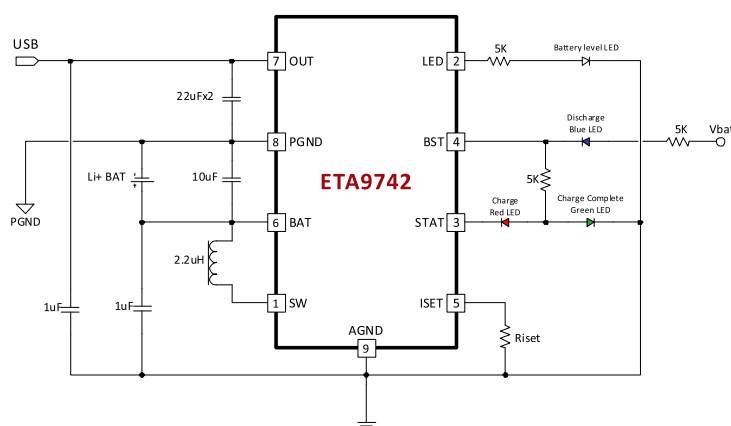

ORDERING INFORMATION

PART No.	PACKAGE	TOP MARK	Pcs/Reel
ETA9742E8A	ESOP8	ETA9742	2500

ETA9742

PIN CONFIGURATION

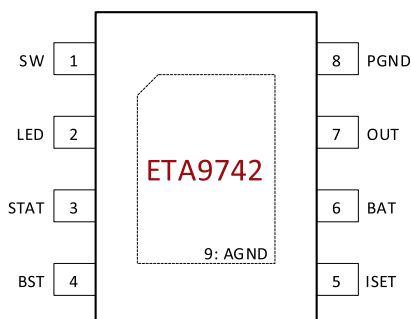

ABSOLUTE MAXIMUM RATINGS

(Note: Exceeding these limits may damage the device. Exposure to absolute maximum rating conditions for long periods may affect device reliability.)

OUT, SW Voltage	-0.3V to 6V
All Other Pin Voltage	-0.3V to 6V
SW to ground current.....	Internally limited
Operating Temperature Range	-40°C to 85°C
Storage Temperature Range	-55°C to 150°C
Thermal Resistance	θ_{JA} θ_{JC}
ESDP8	10 50 °C/W
Lead Temperature (Soldering, 10ssec)	260°C
ESD HBM (Human Body Mode)	2KV
ESD MM (Machine Mode)	200V

ELECTRICAL CHARACTERISTICS

(V_{IN} = 5V, unless otherwise specified. Typical values are at T_A = 25°C.)

PARAMETER	CONDITIONS	MIN	TYP	MAX	UNITS
BUCK MODE					
USB Range		4.5		5.5	V
USB UVLO Voltage	Rising, Hys=500mV		4.5		V
USB Operating Current as BUCK	Switcher Enable, Switching		5		mA
	Switcher Enable, No Switching		800		μ A
BATTERY CHARGER					
Battery CV Voltage	I_{BAT} = 0mA, default	4.17	4.21	4.25	V
Charger Restart Threshold	From DONE to Fast Charge		-160		mV
Battery Pre-Condition Voltage	V_{BAT} Rising Hys=250mV		2.8		V
Pre-Condition Charge Current			200		mA
Fast Charge Current	Riset=56K		3		A
	Riset=91K		2		A
Charge Termination Current			200		mA
Charge Termination Blanking time			16		S
BOOST MODE					
BATT Ok Threshold	Rising, HYS=0.4 V		3.2		V
Output Voltage Range	I_{out} =0	5.05	5.1	5.15	V
Quiescent Current At BATT	V_{bat} =3.6V		80		μ A
Switching Frequency	V_{IN} <4.3V	550	650	750	KHz
Inductor Peak Current Limit			5.0		A
Maximum Duty Cycle			90		%
High side Pmos R_{dson}	I_{SW} = 500mA		75		m Ω



ETA9742

PARAMETER	CONDITIONS	MIN	TYP	MAX	UNITS
Low side Nmos Rdson	I _{sw} =500mA		70		mΩ
Short Circuit Hiccup Current			3.8		A
Short Circuit Hiccup Timer	On Time		45		ms
	Off Time		2000		
Charging Thermal Regulation threshold			85		°C
Thermal Shutdown	Rising, Hys=20°C		150		°C

PIN DESCRIPTION

PIN #	NAME	DESCRIPTION
1	SW	Inductor Connection. Connect an inductor Between SW and the regulator output
2	LED	Battery level indication LED connection pin.
3	STAT	Charge status indication. When charging, the STAT is pulled low. When charge is completed the STAT is in high impedance state.
4	BST	Boost status indication. BST is pulled low when boost, pulled high when charging, and in high impedance if entering into no load condition.
5	ISET	Buck Charging current setting pin. Connect a resistor between this pin and analog ground to set the current level.
6	BAT	Battery pin. Connect a Battery to this pin, and with a bypass capacitor 10uF.
7	OUT	Output pin. Bypass with a 22uF or larger ceramic capacitor closely between this pin and GND
8	PGND	Power Ground Pin
9 / Exposed Pad	AGND	Analog Ground Pin

TYPICAL CHARACTERISTICS

(Vin=5V, T_A=25°C, unless otherwise specified)

In CHARGE MODE, Efficiency Vs Vbat at 2.1A and 3A charge current

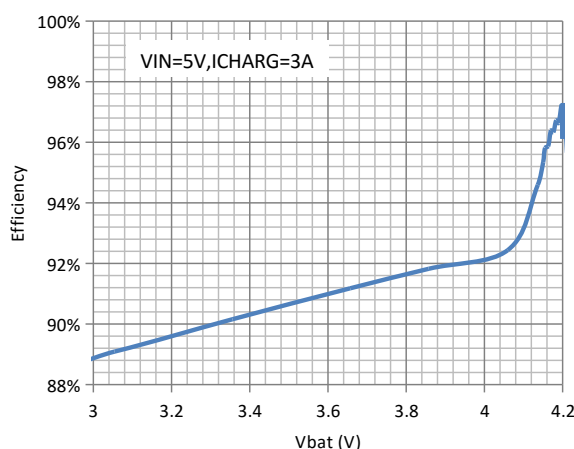
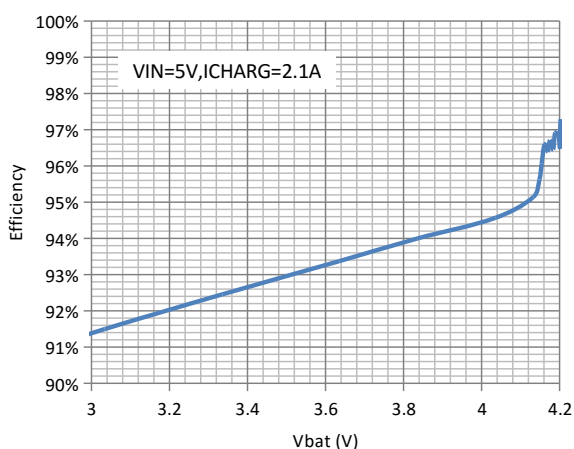

ETA9742

In BOOST MODE

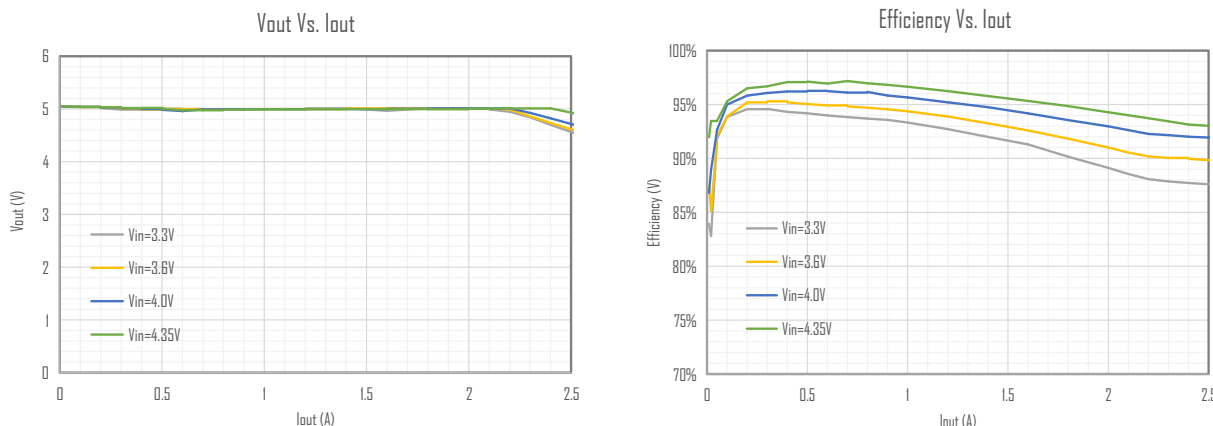

APPLICATION SUPPORT

Please contact local distributor or ETA sales representatives for technical support.

PCB GUIDELINES

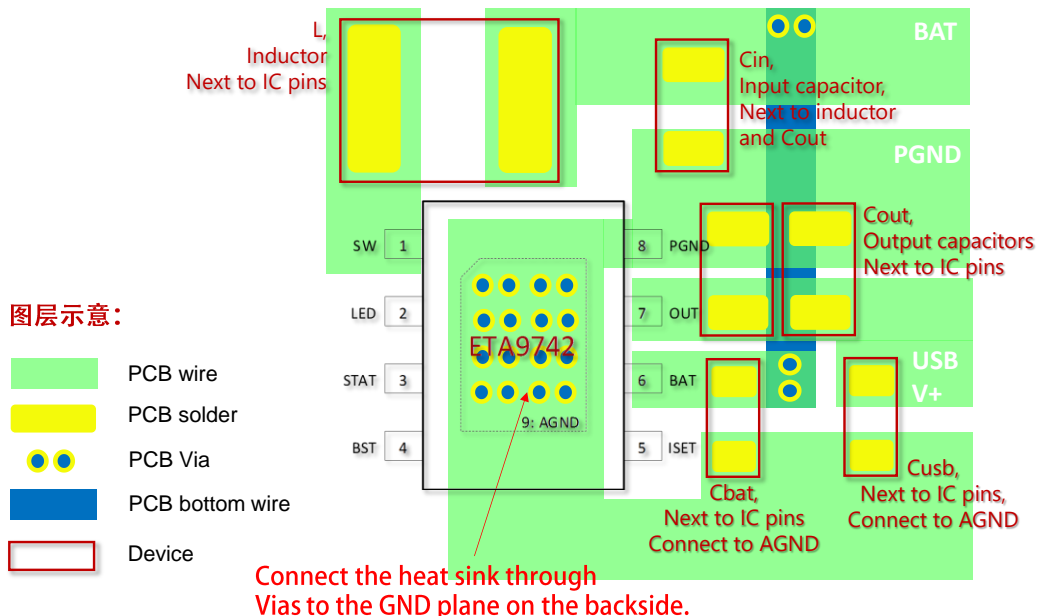

Please have C_{IN} , C_{OUT} , and L placed just next to the IC pins so that the power traces are kept to the shortest to achieve a good performance of ETA9742 and good EMI.

Have C_{BAT} and C_{USB} placed close to the IC pins and connected to AGND to ensure a clean AGND.

ETA9742

PACKAGE OUTLINE

Package: ESOP-8

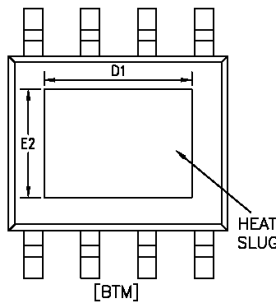
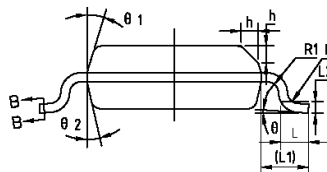
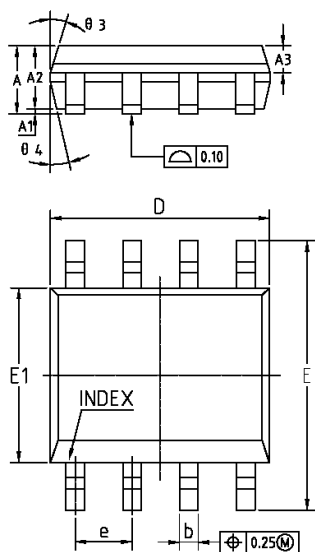

COMMON DIMENSIONS
(UNITS OF MEASURE=MILLIMETER)

SYMBOL	MIN	NOM	MAX
A	1.35	1.55	1.75
A1	0	0.10	0.15
A2	1.25	1.40	1.65
A3	0.50	0.60	0.70
b	0.38	-	0.51
b1	0.37	0.42	0.47
c	0.17	-	0.25
c1	0.17	0.20	0.23
D	4.80	4.90	5.00
D1	3.10	3.30	3.50
E	5.80	6.00	6.20
E1	3.80	3.90	4.00
E2	2.20	2.40	2.60
e	1.27BSC		
L	0.45	0.60	0.80
L1	1.04REF		
L2	0.25BSC		
R	0.07	-	-
R1	0.07	-	-
h	0.30	0.40	0.50
theta	0°	-	8°
theta 1	15°	17°	19°
theta 2	11°	13°	15°
theta 3	15°	17°	19°
theta 4	11°	13°	15°

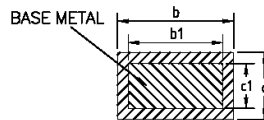

NOTES:
ALL DIMENSIONS REFER TO JEDEC STANDARD MS-012 AA
DO NOT INCLUDE MOLD FLASH OR PROTRUSIONS.