

Typical Applications

- Digital Communication Systems
- Spread-Spectrum Communication Systems
- Driver for Higher Power Linear Applications
- Portable Battery-Powered Equipment
- Commercial and Consumer Systems
- Base Station Equipment

Product Description

The RF2114 is a medium to high power linear amplifier IC. The device is manufactured on an advanced Gallium Arsenide Heterojunction Bipolar Transistor (HBT) process, and has been designed for use as the final linear RF amplifier in UHF radio transmitters operating between 1MHz and 600MHz. It may also be used as a driver amplifier in higher power applications. The device is self-contained with the exception of the output matching network, power supply feed line, and bypass capacitors. The device can be used in 3-cell battery applications. The maximum CW output at 3V is 125mW. The unit has a total gain of 35dB, depending upon the output matching network.

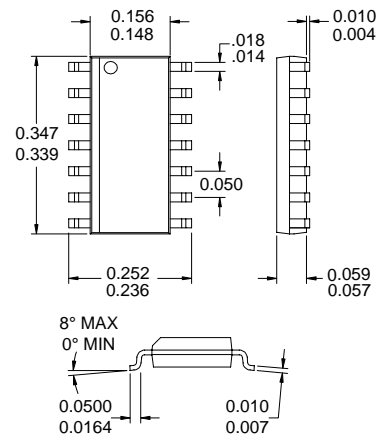

Optimum Technology Matching® Applied

- Si BJT GaAs HBT GaAs MESFET
 Si Bi-CMOS SiGe HBT Si CMOS

Package Style: SOIC-14

- Features
- 1 MHz to 600MHz Operation
 - Over 800mW CW Output Power
 - 35dB Small Signal Gain
 - Single 2.7V to 6.5V Supply
 - 45% Efficiency
 - Digitally Controlled Power Down Mode

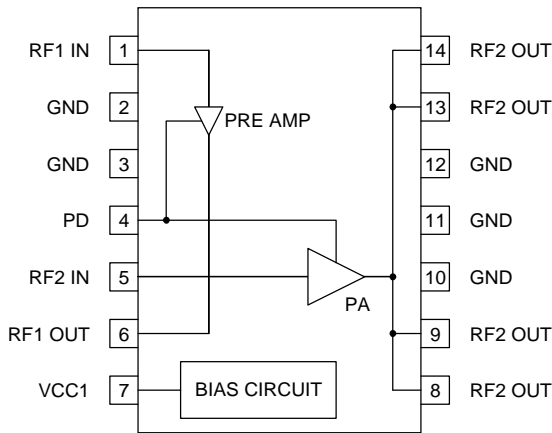

Functional Block Diagram

Ordering Information

RF2114	Medium Power Linear Amplifier
RF2114 PCBA	Fully Assembled Evaluation Board

RF Micro Devices, Inc.
7625 Thorndike Road
Greensboro, NC 27409, USA

Tel (336) 664 1233
Fax (336) 664 0454
<http://www.rfmd.com>

RF2114

Absolute Maximum Ratings

Parameter	Rating	Unit
Supply Voltage	-0.5 to +8.5	V _{DC}
Power Down Voltage (V _{PD})	-0.5 to +5.0	V
DC Supply Current	500	mA
Input RF Power	+12	dBm
Output Load VSWR	20:1	
Operating Ambient Temperature	-40 to +85	°C
Storage Temperature	-40 to +150	°C



Caution! ESD sensitive device.

RF Micro Devices believes the furnished information is correct and accurate at the time of this printing. However, RF Micro Devices reserves the right to make changes to its products without notice. RF Micro Devices does not assume responsibility for the use of the described product(s).

Parameter	Specification			Unit	Condition
	Min.	Typ.	Max.		
Overall					T=25°C, V _{CC} =5.8V, V _{PD} =4.0V, Z _{LOAD} =18Ω, P _{IN} =6dBm, Freq=150MHz
Frequency Range		1 to 600		MHz	
Saturated Output Power	+28	+29	+31	dBm	
Output Power		>+27		dBm	Frequency > 450MHz
Power Gain	30	36	40	dB	
CW Total Efficiency		45		%	
Two Tone Total Efficiency		26		%	P _{OUT} = +19dBm/tone
IM ₃	-50	-40	-25	dBc	P _{OUT} = +19dBm/tone
IM ₅	-70	-43	-30	dBc	P _{OUT} = +19dBm/tone
Second Harmonic		-24		dBc	Without external second harmonic trap
Third Harmonic		-30		dBc	
Output Noise Power		<-125		dBm/Hz	
Input VSWR		<3:1			With external matching network; see application schematic
Input Impedance		50		Ω	With external matching network; see application schematic
Load Impedance		18+j0		Ω	Load impedance for optimal match
Power Down Control					
Power Down "ON"		V _{CC}		V	Voltage supplied to the input; Part is "ON"
Power Down "OFF"	0		0.2	V	Voltage supplied to the input; Part is "OFF"
Power Supply					
Power Supply Voltage		2.7 to 6.5		V	
Power Supply Idle Current		45	90	mA	
Supply Current	150	300	500	mA	Total of pins 5 and 6
V _{PD} Current		<3.5		mA	Into pin 4
Total "OFF" Current Drain			10	μA	V _{PD} < 0.1V _{DC}
Turn-on Time		<100		ns	V _{PD} =0 to V _{PD} =+4V _{DC}

Pin	Function	Description	Interface Schematic
1	RF1 IN	RF input pin. This pin is internally connected to the bias circuits. An external DC blocking capacitor is required. The value of this capacitor depends on the actual operating frequency.	
2	GND	Ground connection. Keep the connection to the backside ground plane as short as possible, by placing the vias close to the pin.	
3	GND	Same as pin 2.	
4	PD	Power down control voltage. When this pin is at 0V, the device will be in power down mode, dissipating minimum DC power. When this pin is at V_{CC} (but not higher than 5.0V max), the device will be in full power mode delivering maximum gain and output power capability. This pin may also be used to perform some degree of gain control or power control when set to voltages between 0V and V_{CC} or 5.0V, whichever is the lowest. It is not optimized for this function so the transfer function is not linear over a wide range as with other devices specifically designed for analog gain control. However, it may be usable for coarse adjustment or in some closed loop AGC systems. This pin should not, in any circumstance, be higher in voltage than V_{CC} . This pin should also have an external bypassing capacitor.	
5	RF2 IN	RF input of the power stage. This pin is internally connected to the bias circuits. An external DC blocking capacitor is required. This same capacitor can also be used for interstage matching. Typically this capacitor is between RF2 IN (pin 5) and RF1 OUT (pin 6); see the application schematics for details.	
6	RF1 OUT	RF output of the pre-amplifier. Power supply needs to be supplied to this pin through an inductor to V_{CC} . Together with the series capacitor between pin 5 and 6 the interstage matching circuit is formed. See the application schematics for values for different frequencies.	
7	VCC1	Positive supply for the active bias circuits. This needs to be bypassed with a single capacitor, placed as close as possible to the package. Additional bypassing of 1 μ F is also recommended, but proximity to the package is not as critical.	
8	RF2 OUT	Amplifier RF output. This is an unmatched collector output of the final amplifier transistor. Pins 8, 9, 13, and 14 are connected internally. Bias for the final power amplifier output transistor must also be provided through one of these two pins. Typically, pins 8 and 9 are connected to a network that provides the DC bias and also creates a second harmonic trap. A capacitor series resonates with internal bond wires and some additional series inductance, and acts as a trap at two times the operating frequency, effectively shorting out the second harmonic. Shorting out this harmonic serves to increase the amplifier's maximum output power and efficiency, as well as to lower the level of the second harmonic output. Typically, pins 13 and 14 are externally connected very close to the package and used as the RF output with a matching network that presents the optimum load impedance to the PA for maximum power and efficiency, as well as providing DC blocking at the output.	
9	RF2 OUT	Same as pin 8.	
10	GND	Same as pin 2.	
11	GND	Same as pin 2.	
12	GND	Same as pin 2.	
13	RF2 OUT	Same as pin 8.	
14	RF2 OUT	Same as pin 8.	

RF2114

Application Schematic for 150MHz Operation

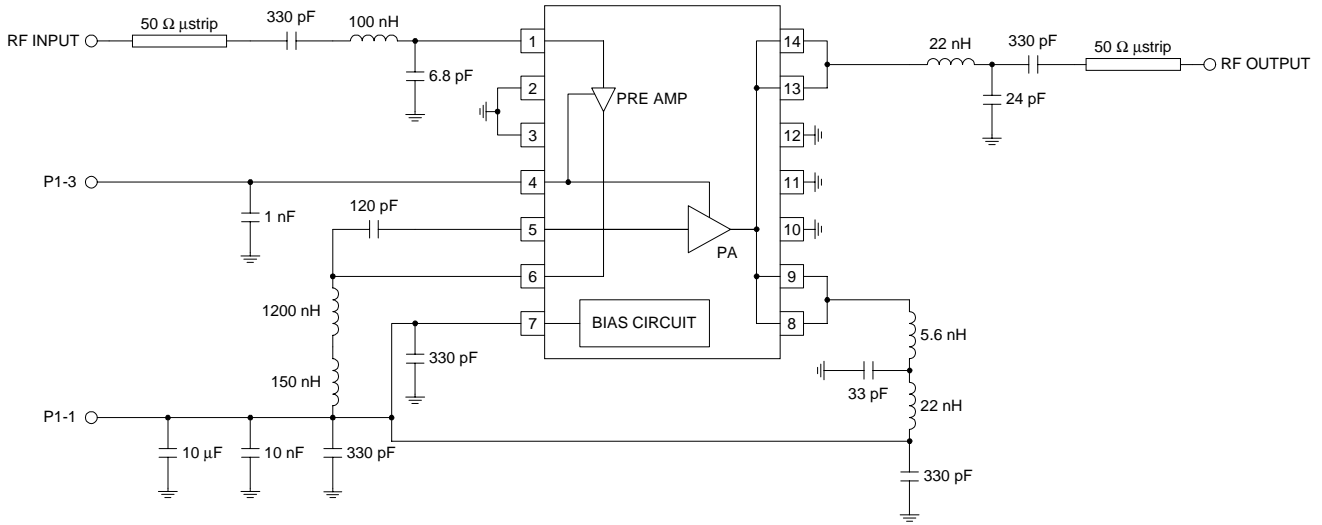

Application Schematic for 450MHz Operation

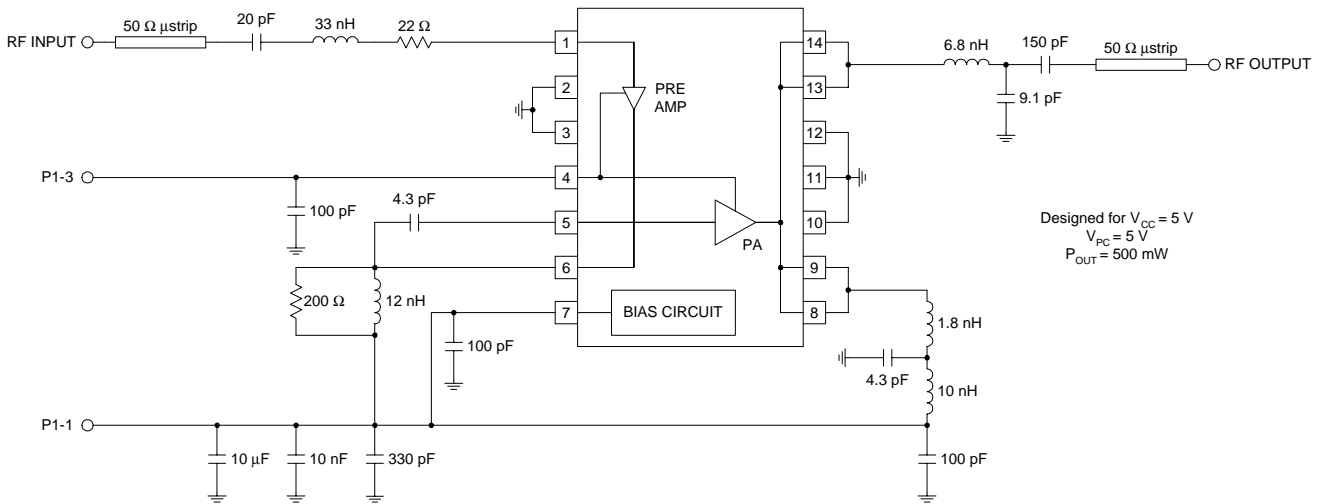

Evaluation Board Schematic (150MHz)

(Download [Bill of Materials](http://www.rfmd.com) from www.rfmd.com.)

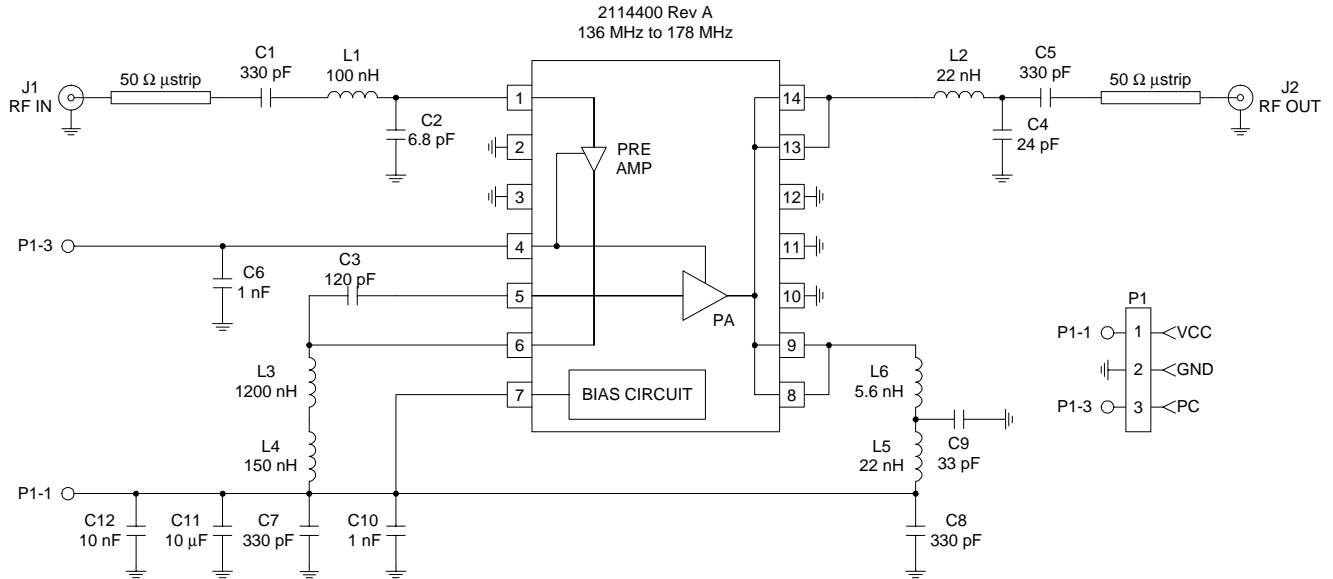

Evaluation Board Layout 2" x 3"

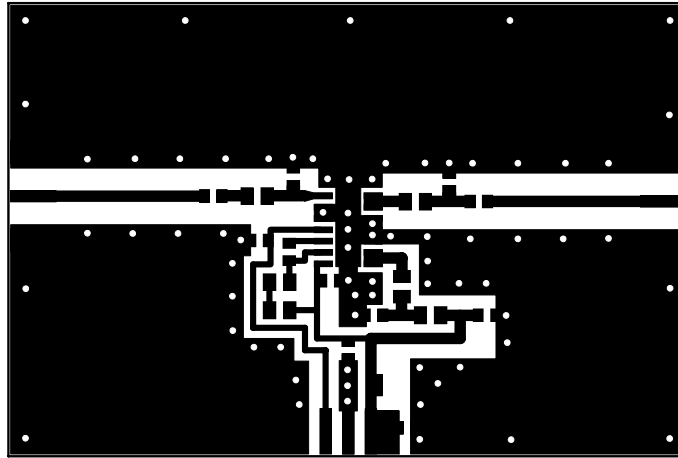
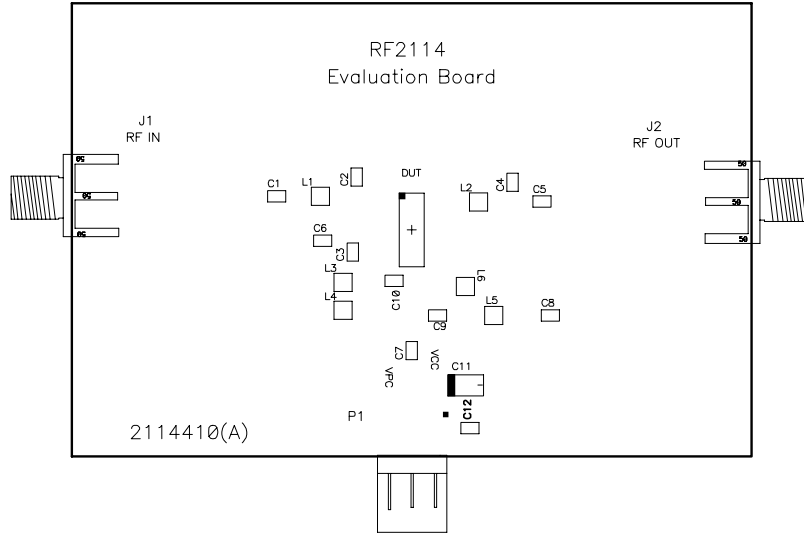

This datasheet has been download from:

www.datasheetcatalog.com

Datasheets for electronics components.