

TA8435H/HQ

PWM CHOPPER-TYPE BIPOLAR STEPPING MOTOR DRIVER.

The TA8435H/HQ is a PWM chopper-type sinusoidal micro-step bipolar stepping motor driver.

Sinusoidal micro-step operation is achieved using only a clock signal input by means of built-in hardware.

FEATURES

- Single-chip bipolar sinusoidal micro-step stepping motor driver
- Output current up to 1.5 A (AVE.) and 2.5 A (PEAK)
- PWM chopper-type
- Structured by high voltage Bi-CMOS process technology
- Forward and reverse rotation are available
- 2-, 1-2-, W1-2-, and 2W1-2-phase modes, and one- or two-clock drives can be selected.
- Package: HZIP25-P
- Input pull-up resistor equipped with $\overline{\text{RESET}}$ pin: $R = 100 \text{ k}\Omega$ (typ.)
- Output monitor available with MO I_0 ($\overline{\text{MO}}$) = $\pm 2 \text{ mA}$ (MAX.)
- Equipped with $\overline{\text{RESET}}$ and $\overline{\text{ENABLE}}$ pins.

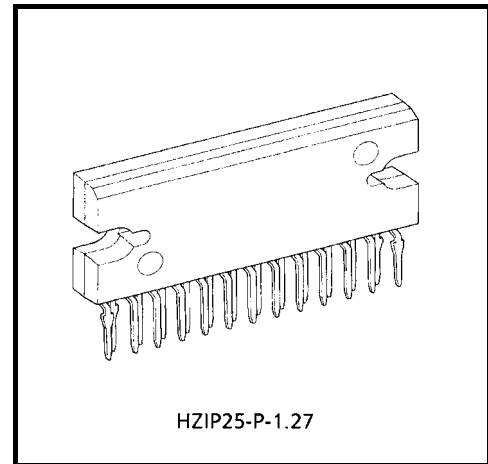

HZIP25-P-1.27

Weight: 9.86 g (typ.)

TA8435HQ:

The TA8435HQ is an Sn-plated product that includes Pb.

The following conditions apply to solderability:

*Solderability

1. Use of Sn-63 Pb solder bath
 - *solder bath temperature = 230°C
 - *dipping time = 5 seconds
 - *number of times = once
 - *use of R-type flux
2. Use of Sn-3.0Ag-0.5Cu solder bath
 - *solder bath temperature = 245°C
 - *dipping time = 5 seconds
 - *number of times = once
 - *use of R-type flux

BLOCK DIAGRAM

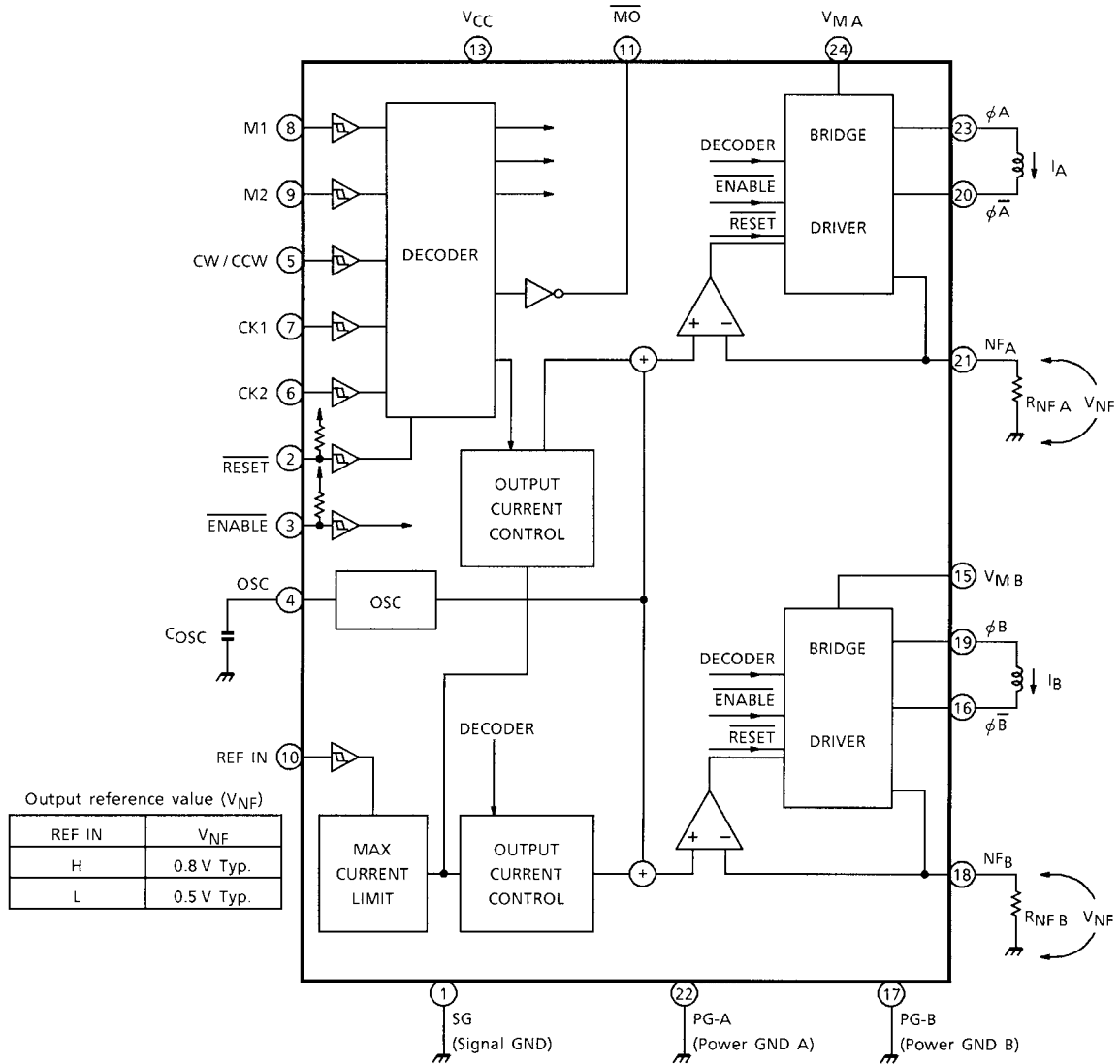

Pull-up resistance : 100 k Ω (Typ.)

Pin 12、14、25 : Non-connection

PIN CONNECTION (top view)

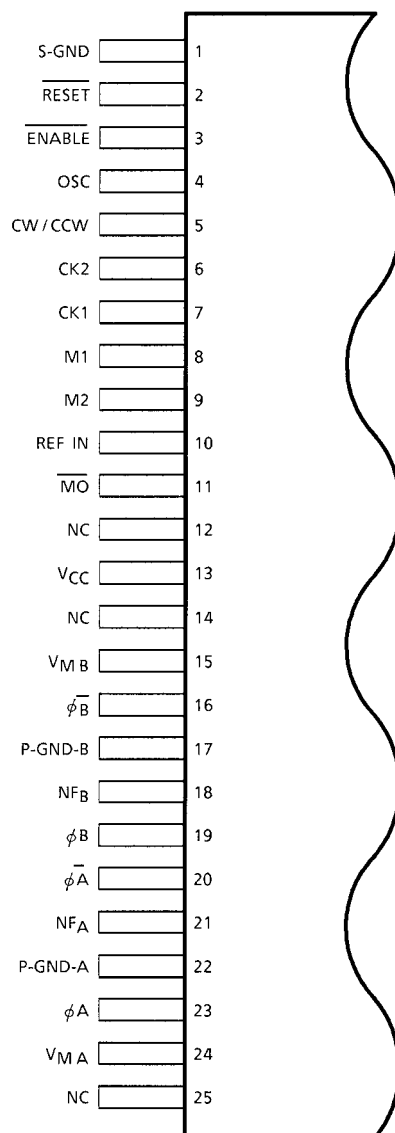

Note: NC: No connection

PIN FUNCTION

PIN No	SYMBOL	FUNCTIONAL DESCRIPTION
1	SG	Signal GND
2	$\overline{\text{RESET}}$	L : RESET
3	$\overline{\text{ENABLE}}$	L : ENABLE, H: OFF
4	OSC	Chopping oscillation is determined by the external capacitor
5	CW / CCW	Forward / Reverse switching terminal.
6	CK2	Clock input terminal.
7	CK1	Clock input terminal.
8	M1	Excitation control input
9	M2	Excitation control input
10	REF IN	V_{NF} control input
11	$\overline{\text{MO}}$	Monitor output
12	NC	No connection.
13	V_{CC}	Voltage supply for logic.
14	NC	No connection.
15	V_{MB}	Output power supply terminal.
16	$\phi \overline{\text{B}}$	Output $\phi \overline{\text{B}}$
17	PG-B	Power GND.
18	NF_{B}	B-ch output current detection terminal.
19	ϕB	Output ϕB
20	$\phi \overline{\text{A}}$	Output $\phi \overline{\text{A}}$
21	NF_{A}	A-ch output current detection terminal.
22	PG-A	Power GND
23	ϕA	Output ϕA
24	V_{MA}	Output power supply terminal.
25	NC	No connection

OUTPUT CIRCUIT

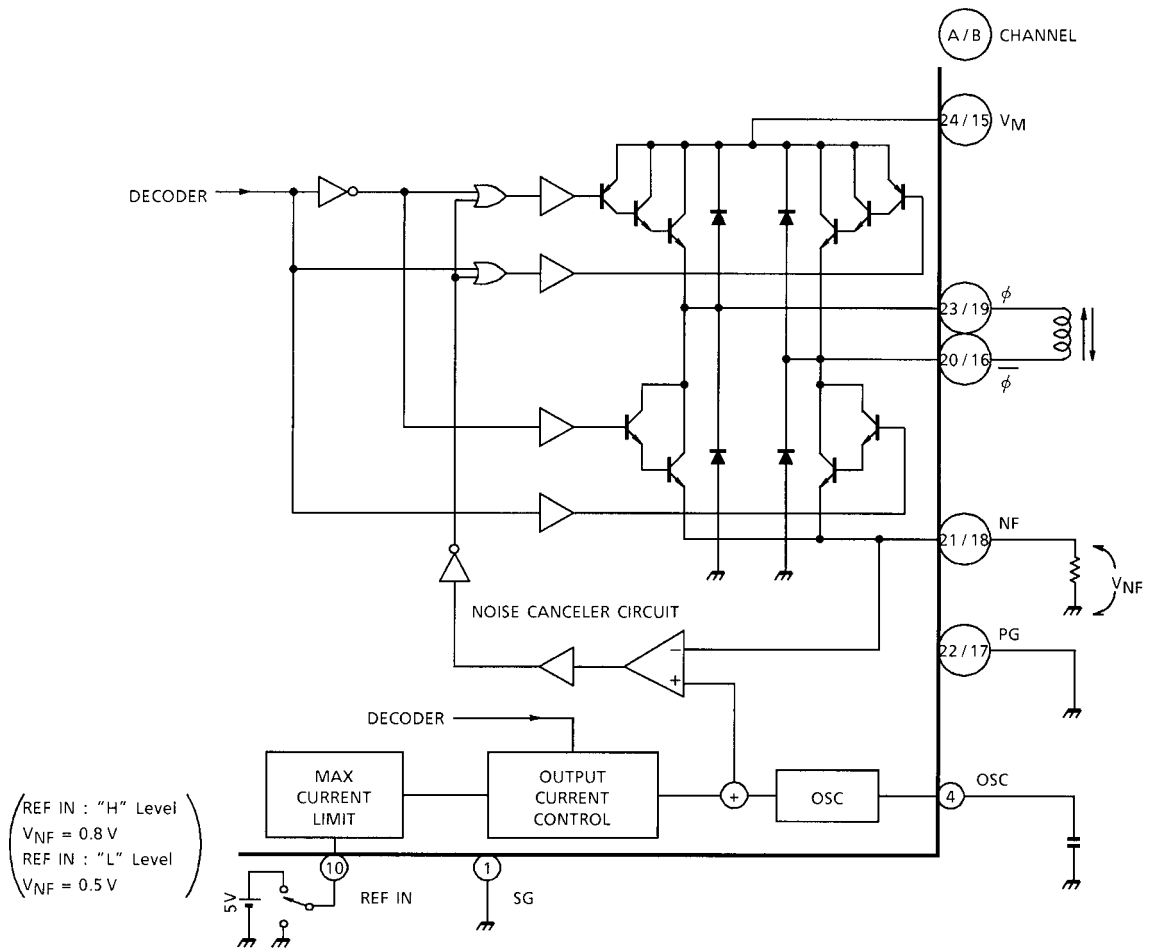

INPUT CIRCUIT

- CK1, CK2, CW / CCW, M1, M2, REF IN: Terminals
- $\overline{\text{RESET}}$, $\overline{\text{ENABLE}}$: Terminals
- OSC: Terminal

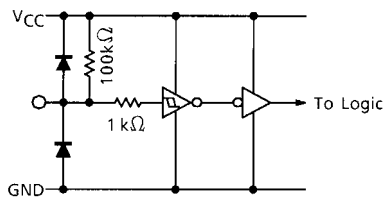
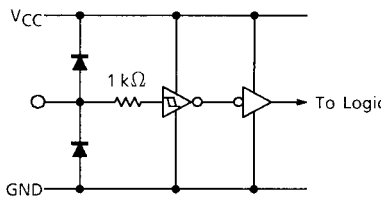

Equipped with 100 kΩ of pull-up resistance.

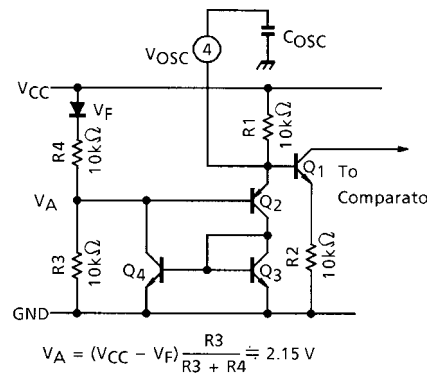

OSCILLATOR FREQUENCY CALCULATION

The sawtooth oscillator (OSC) circuit consists of Q₁ through Q₄ and R₁ through R₄. Q₂ is turned off when V_{OSC} is less than the voltage of 2.5 V + V_{BE} (Q₂), a value that is approximately equal to 2.85 V. V_{OSC} is increased by C_{OSC} charging through R₁. Q₃ and Q₄ are turned on when V_{OSC} becomes 2.85 V (High level.) The Low level of V (4) pin is equal to V_{BE}(Q₂) + V_(SAT)(Q₄), which is approximately equal to 1.4 V. V_{OSC} is calculated by following equation:

$$V_{OSC} = 5 \cdot \left[1 - \exp\left(-\frac{1}{C_{OSC} \cdot R_1}\right) \right] \dots\dots\dots (1).$$

Assuming that V_{OSC} = 1.4 V (t = t₁) and = 2.85 V (t = t₂), and given that C_{OSC} is the external capacitance connected to pin (4) and R₁ is an on-chip 10 kΩ resistor, the OSC frequency is calculated as follows:

$$t_1 = -C_{OSC} \cdot R_1 \cdot \ln \left(1 - \frac{1.4}{5} \right) \dots\dots\dots (2),$$

$$t_2 = -C_{OSC} \cdot R_1 \cdot \ln \left(1 - \frac{2.85}{5} \right) \dots\dots\dots (3),$$

$$f_{OSC} = \frac{1}{t_2 - t_1} = \frac{1}{C_{OSC} \left(R_1 \cdot \ln \left(1 - \frac{1.4}{5} \right) - R_1 \cdot \ln \left(1 - \frac{2.85}{5} \right) \right)}$$

$$= \frac{1}{5.15 \cdot C_{OSC}} \text{ (kHz) } (C_{OSC} : \mu\text{F}).$$

ENABLE AND RESET FUNCTION AND \overline{MO} SIGNAL

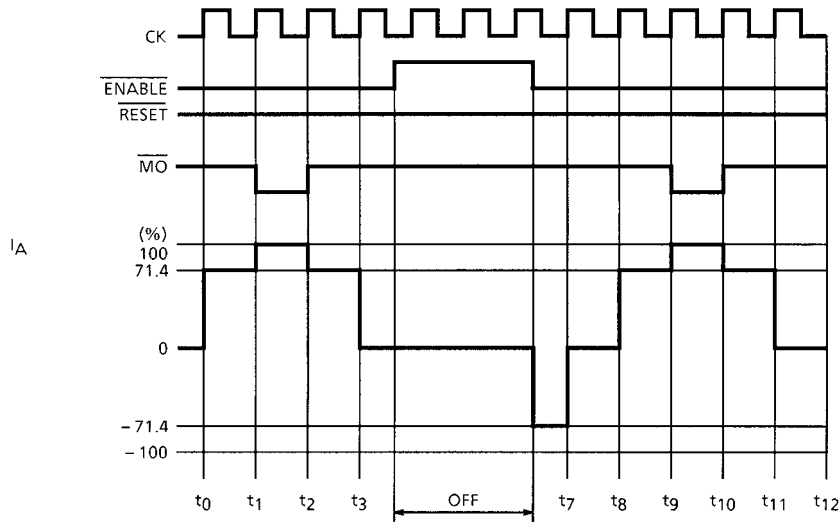

Figure 1: 1-2 phase drive mode (M1: H, M2: L)

The \overline{ENABLE} signal at High level disables only the output signals. Internal logic functions proceed in accordance with input clock signals and without regard to the \overline{ENABLE} signal. Therefore output current is initiated by the timing of the internal logic circuit after release of disable mode. Figure 1 shows the \overline{ENABLE} functions for when 1-2 phase drive is selected for the system.

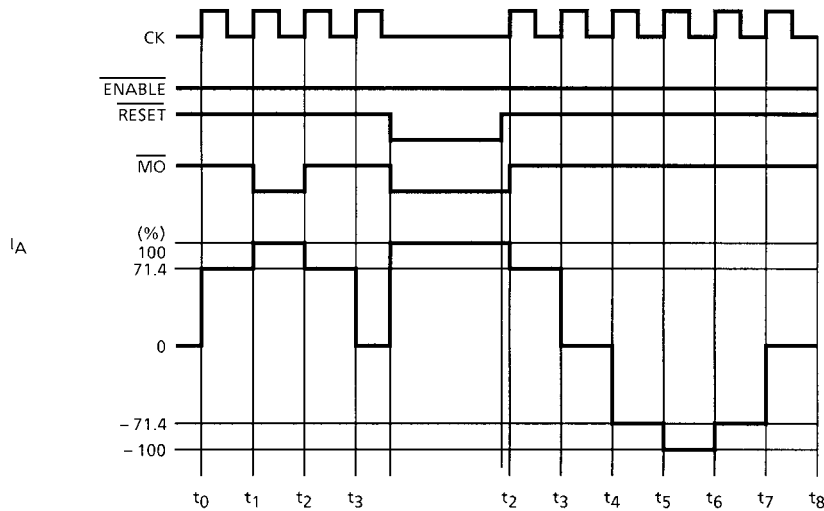

Figure 2: 1-2 phase drive mode (M1: H, M2: L)

The \overline{RESET} signal at Low level not only turns off the output signals but also stops the internal clock functions, while \overline{MO} (Monitor Output) signals are set to low. Output signals are initiated from the initial point after release of \overline{RESET} (High), as shown in Figure 2. \overline{MO} signals can be used as rotation and initial signals for stable rotation checking.

FUNCTION

INPUT					MODE
CK1	CK2	CW / CCW	RESET	ENABLE	
	H	L	H	L	CW
	L	L	H	L	INHIBIT (Note)
H		L	H	L	CCW
L		L	H	L	INHIBIT (Note)
	H	H	H	L	CCW
	L	H	H	L	INHIBIT (Note)
H		H	H	L	CW
L		H	H	L	INHIBIT (Note)
X	X	X	L	L	RESET
X	X	X	X	H	Z

INITIAL MODE

EXCITATION MODE	A PHASE CURRENT	B PHASE CURRENT
2-Phase	100%	-100%
1-2-Phase	100%	0%
W1-2-Phase	100%	0%
2W1-2-Phase	100%	0%

Z: High Impedance

X: Don't Care

INPUT		MODE (EXCITATION)
M1	M2	
L	L	2-Phase
H	L	1-2-Phase
L	H	W1-2-Phase
H	H	2W1-2-Phase

2-PHASE EXCITATION (M1: L, M2: L, CW MODE)

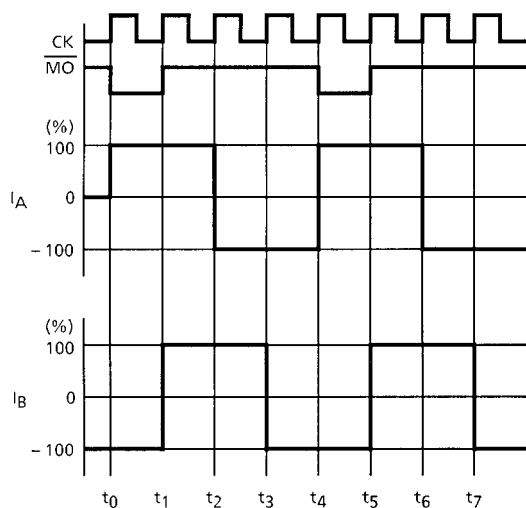

1-2-PHASE EXCITATION (M1: H, M2: L, CW MODE)

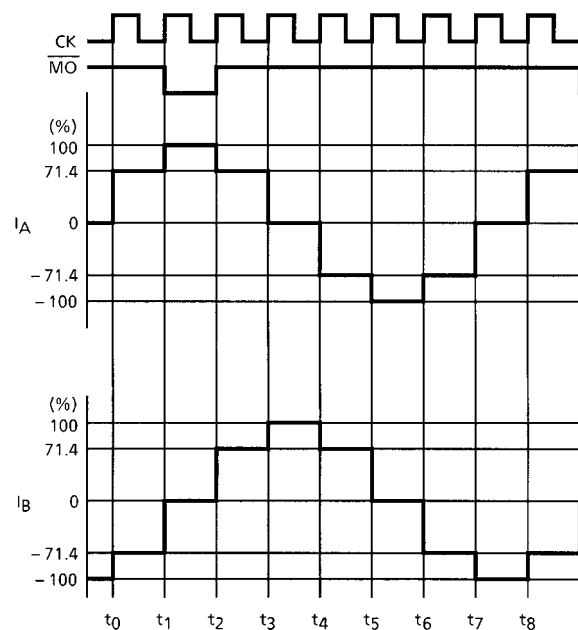

W1-2-PHASE EXCITATION (M1: L, M2: H, CW MODE)

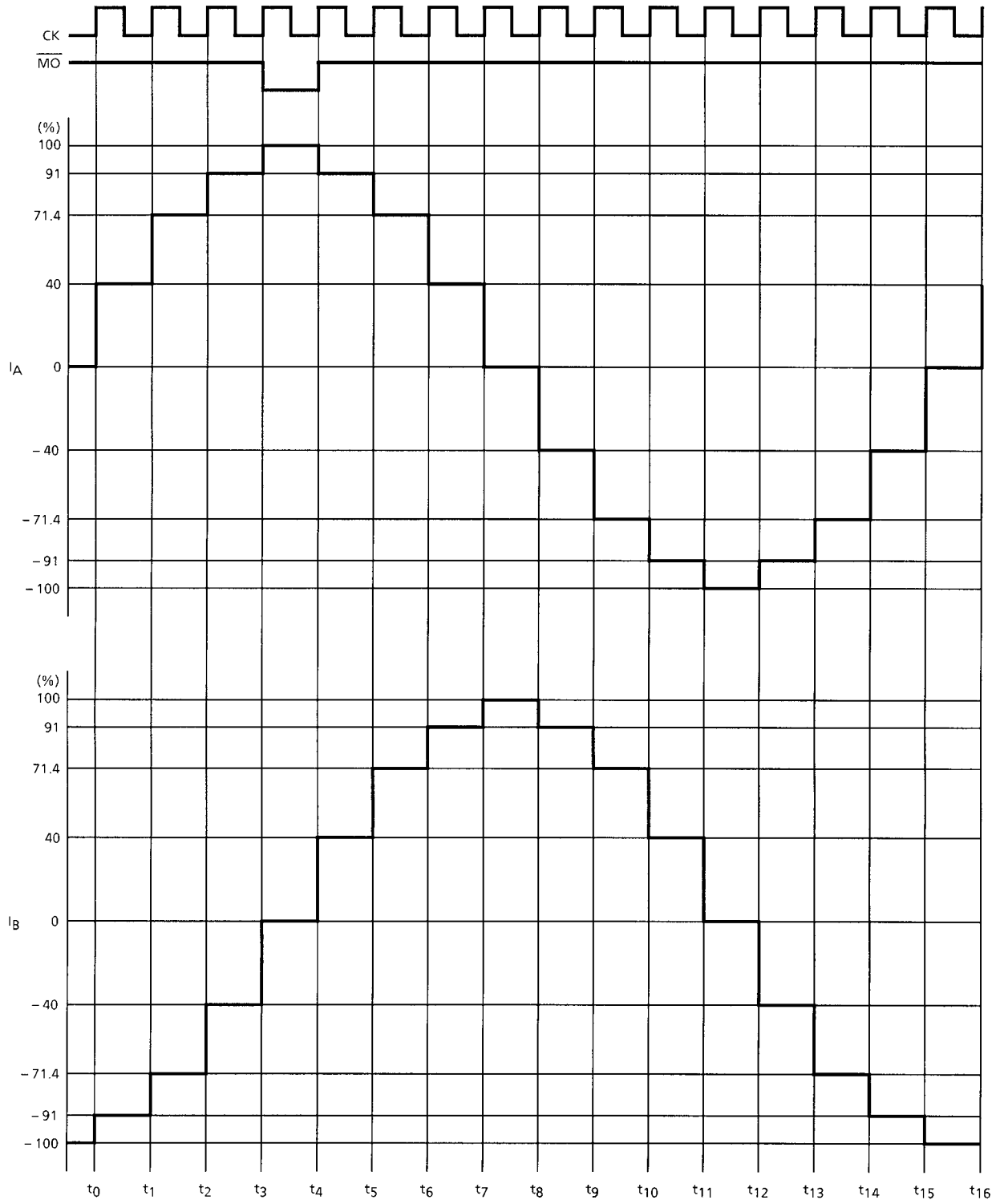

2W1-2-PHASE EXCITATION (M1: H, M2: H, CW MODE)

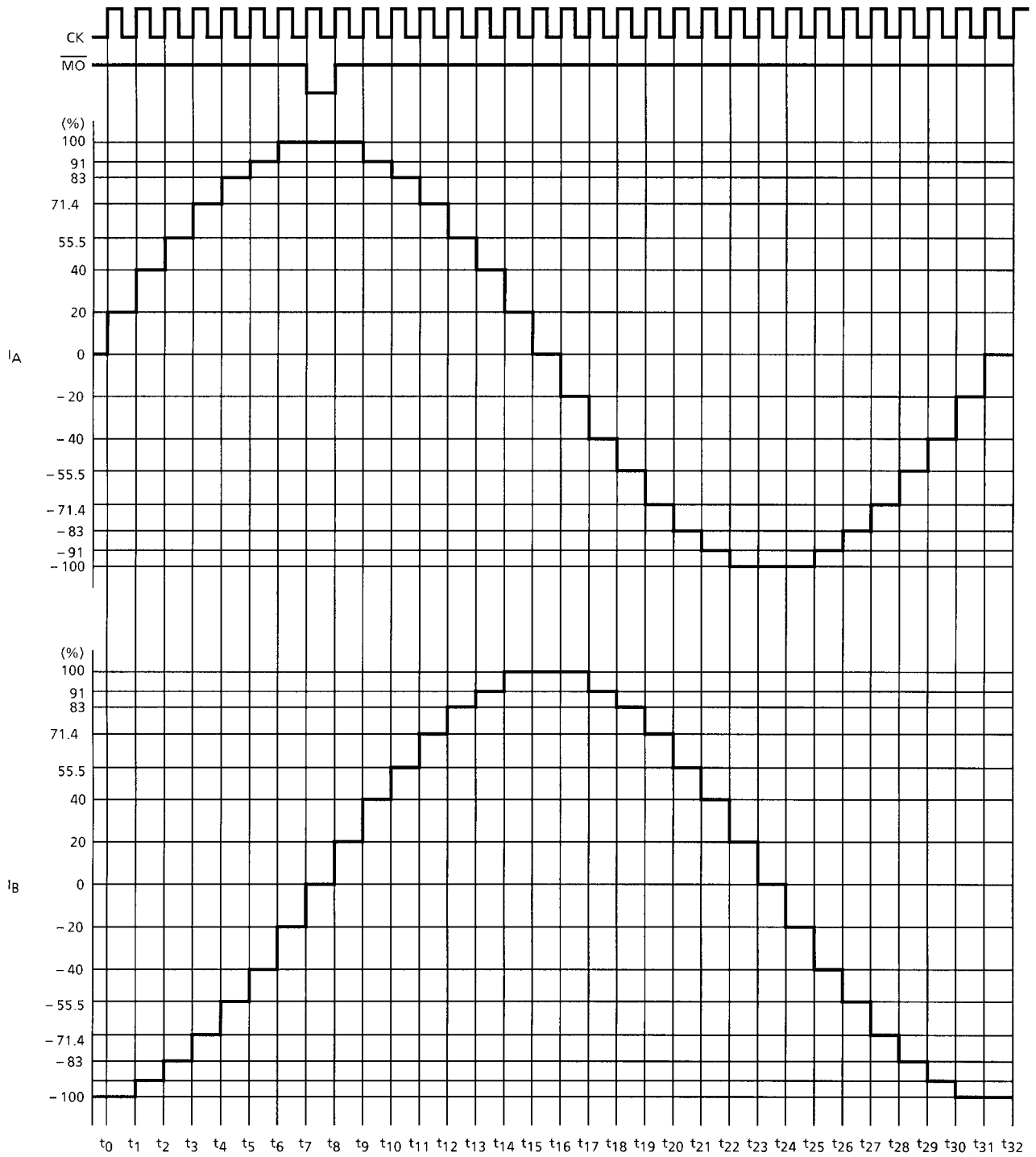

MAXIMUM RATINGS (Ta = 25°C)

CHARACTERISTIC		SYMBOL	RATING	UNIT
Supply Voltage		V _{CC}	5.5	V
Output Voltage		V _M	40	V
Output Current	PEAK	I _O (PEAK)	2.5	A
	AVE	I _O (AVE.)	1.5	
\overline{MO} Output Current		I _O (\overline{MO})	±2	mA
Input Voltage		V _{IN}	~V _{CC}	V
Power Dissipation		P _D	5 (Note 1)	W
			43 (Note 2)	
Operating Temperature		T _{opr}	-40~85	°C
Storage Temperature		T _{stg}	-55~150	°C
Feed Back Voltage		V _{NF}	1.0	V

Note 1: No heat sink

Note 2: T_c = 85°C

RECOMMENDED OPERATING CONDITIONS (Ta = -20~75°C)

CHARACTERISTIC	SYMBOL	TEST CONDITION	MIN	TYP.	MAX	UNIT
Supply Voltage	V _{CC}	—	4.5	5.0	5.5	V
Output Voltage	V _M	—	21.6	24	26.4	V
Output Current	I _{OUT}	—	—	—	1.5	A
Input Voltage	V _{IN}	—	—	—	V _{CC}	V
Clock Frequency	f _{CK}	—	—	—	5	kHz
OSC Frequency	f _{OSC}	—	15	—	80	kHz

ELECTRICAL CHARACTERISTICS (Ta = 25°C, VCC = 5 V, VM = 24 V)

CHARACTERISTIC		SYMBOL	TEST CIR-CUIT	TEST CONDITION	MIN	TYP.	MAX	UNIT	
Input Voltage	High	$V_{IN(H)}$	1	M1, M2, CW / CCW, REF IN \overline{ENABLE} , CK1, CK2 RESET	3.5	—	$V_{CC} + 0.4$	V	
	Low	$V_{IN(L)}$			GND - 0.4	—	1.5		
Input Hysteresis Voltage		V_H			—	600	—	mV	
Input Current		$I_{IN-1(H)}$	1	M1, M2, REF IN, $V_{IN} = 5.0$ V	—	—	100	nA	
		$I_{IN-1(L)}$		\overline{RESET} , \overline{ENABLE} , $V_{IN} = 0$ V INTERNAL PULL-UP RESISTOR	10	50	100	μ A	
		$I_{IN-2(L)}$		SOURCE TYPE, $V_{IN} = 0$ V	—	—	100	nA	
Quiescent Current VCC Terminal		I_{CC1}	1	Output Open, $\overline{RESET} : H$ $\overline{ENABLE} : L$ (2, 1-2 phase excitation)	—	10	18	mA	
		I_{CC2}		Output Open, $\overline{RESET} : H$ $\overline{ENABLE} : L$ (W1-2, 2W1-2 phase excitation)	—	10	18		
		I_{CC3}		$\overline{RESET} : L$, $\overline{ENABLE} : H$	—	5	—		
		I_{CC4}		$\overline{RESET} : H$, $\overline{ENABLE} : H$	—	5	—		
Comparator Reference Voltage	High	$V_{NF(H)}$	3	REF IN H Output Open	(Note)	0.72	0.8	0.88	V
	Low	$V_{NF(L)}$		REF IN L Output Open		0.45	0.5	0.55	
Output Differential		ΔV_O	—	B / A, $C_{OSC} = 0.0033 \mu F$, $R_{NF} = 0.8 \Omega$	-10	—	10	%	
$V_{NF(H)} - V_{NF(L)}$		ΔV_{NF}	—	$V_{NF(L)} / V_{NF(H)}$ $C_{OSC} = 0.0033 \mu F$, $R_{NF} = 0.8 \Omega$	56	63	70	%	
NF Terminal Current		I_{NF}	—	SOURCE TYPE	—	170	—	μ A	
Maximum OSC Frequency		$f_{OSC(MAX.)}$	—	—	100	—	—	kHz	
Minimum OSC Frequency		$f_{OSC(MIN.)}$	—	—	—	—	10	kHz	
OSC Frequency		f_{OSC}	—	$C_{OSC} = 0.0033 \mu F$	25	44	62	kHz	
Minimum Clock Pulse Width		$t_W(CK)$	—	—	—	1.0	—	μ s	
Output Voltage		$V_{OH(MO)}$	—	$I_{OH} = -40 \mu A$	4.5	4.9	V_{CC}	V	
		$V_{OL(MO)}$		$I_{OL} = 40 \mu A$	GND	0.1	0.5		

Note: 2-phase excitation, $R_{NF} = 0.7 \Omega$, $C_{OSC} = 0.0033 \mu F$

OUTPUT BLOCK

CHARACTERISTIC				SYMBOL	TEST CIR-CUIT	TEST CONDITION	MIN	TYP.	MAX	UNIT		
Output Saturation Voltage	Upper Side			$V_{SAT\ U1}$	4	$I_{OUT} = 1.5\ A$	—	2.1	2.8	V		
	Lower Side			$V_{SAT\ L1}$			—	1.3	2.0			
	Upper Side			$V_{SAT\ U2}$		$I_{OUT} = 0.8\ A$	—	1.8	2.2			
	Lower Side			$V_{SAT\ L2}$			—	1.1	1.5			
	Upper Side			$V_{SAT\ U3}$		$I_{OUT} = 2.5\ A$ Pulse width 30 ms	—	2.5	3.0			
	Lower Side			$V_{SAT\ L3}$			—	1.8	2.2			
Diode Forward Voltage	Upper Side			$V_{F\ U1}$	5	$I_{OUT} = 1.5\ A$	—	2.0	3.0	V		
	Lower Side			$V_{F\ L1}$			—	1.5	2.1			
	Upper Side			$V_{F\ U2}$		$I_{OUT} = 2.5\ A$ Pulse width 30 ms	—	2.5	3.3			
	Lower Side			$V_{F\ L2}$			—	1.8	2.5			
Output Dark Current (A + B Channels)				I_{M1}	2	ENABLE : "H" Level, Output Open RESET : "L" Level	—	—	50	μA		
				I_{M2}		ENABLE : "L" Level Output Open RESET : "H" Level	—	8	15	mA		
A-B Chopping Current (Note)	2W1-2 ϕ	W1-2 ϕ	1-2 ϕ	VECTOR	—	$\theta = 0$	REF IN : H $R_{NF} = 0.8\ \Omega$ $C_{OSC} = 0.0033\ \mu F$	—	100	—	%	
	2W1-2 ϕ	—	—			$\theta = 1 / 8$		—	100	—		
	2W1-2 ϕ	W1-2 ϕ	—			$\theta = 2 / 8$		86	91	96		
	2W1-2 ϕ	—	—			$\theta = 3 / 8$		78	83	88		
	2W1-2 ϕ	W1-2 ϕ	1-2 ϕ			$\theta = 4 / 8$		66.4	71.4	76.4		
	2W1-2 ϕ	—	—			$\theta = 5 / 8$		50.5	55.5	60.5		
	2W1-2 ϕ	W1-2 ϕ	—			$\theta = 6 / 8$		35	40	45		
	2W1-2 ϕ	—	—			$\theta = 7 / 8$		15	20	25		
	2 Phase Excitation Mode VECTOR					—		—	—	100		—

Note: Maximum current ($\theta = 0$): 100%
 2W1-2 ϕ : 2W1-2-phase excitation mode
 W1-2 ϕ : W1-2-phase excitation mode
 1-2 ϕ : 1-2-phase excitation mode

CHARACTERISTIC			SYMBOL	TEST CIR-CUIT	TEST CONDITION	MIN	TYP.	MAX	UNIT							
A-B Chopping Current (Note)	2W1-2φ	W1-2φ	1-2φ	VECTOR	—	REF IN : H R _{NF} = 0.8 Ω C _{OSC} = 0.0033 μF			%							
	2W1-2φ	—	—							θ = 0	—	100	—			
	2W1-2φ	—	—							θ = 1 / 8	—	100	—			
	2W1-2φ	W1-2φ	—							θ = 2 / 8	86	91	96			
	2W1-2φ	—	—							θ = 3 / 8	78	83	88			
	2W1-2φ	W1-2φ	1-2φ							θ = 4 / 8	66.4	71.4	76.4			
	2W1-2φ	—	—							θ = 5 / 8	50.5	55.5	60.5			
	2W1-2φ	W1-2φ	—							θ = 6 / 8	35	40	45			
	2W1-2φ	—	—							θ = 7 / 8	15	20	25			
2 Phase Excitation Mode VECTOR					—	100	—									
Feed Back Voltage Step			ΔV _{NF}	—	Δθ = 0 / 8 - 1 / 8	REF IN : H R _{NF} = 0.8 Ω C _{OSC} = 0.0033 μF			mV							
					Δθ = 1 / 8 - 2 / 8					—	0	—				
					Δθ = 2 / 8 - 3 / 8					32	72	112				
					Δθ = 3 / 8 - 4 / 8					24	64	104				
					Δθ = 4 / 8 - 5 / 8					53	93	133				
					Δθ = 5 / 8 - 6 / 8					87	127	167				
					Δθ = 6 / 8 - 7 / 8					84	124	164				
Output T _r Switching Characteristics				7	R _L = 2 Ω, V _{NF} = 0 V, C _L = 15 pF				μs							
										t _r	—	0.3	—			
										t _f	—	2.2	—			
										t _{pLH}	CK~Output			—	1.5	—
										t _{pHL}	CK~Output			—	2.7	—
										t _{pLH}	OSC~Output			—	5.4	—
										t _{pHL}	OSC~Output			—	6.3	—
										t _{pLH}	RESET ~Output			—	2.0	—
										t _{pHL}	RESET ~Output			—	2.5	—
t _{pLH}	ENABLE ~Output			—	5.0	—										
t _{pHL}	ENABLE ~Output			—	6.0	—										
Output Leakage Current	Upper Side		I _{OH}	6	V _M = 30 V				μA							
	Lower Side									I _{OL}	—	—	50			

Note: Maximum current (θ = 0): 100%
 2W1-2φ: 2W1-2-phase excitation mode
 W1-2φ : W1-2-phase excitation mode
 1-2φ : 1-2-phase excitation mode

TEST CIRCUIT 1

V_{IN} (H), (L), I_{IN} (H), (L)

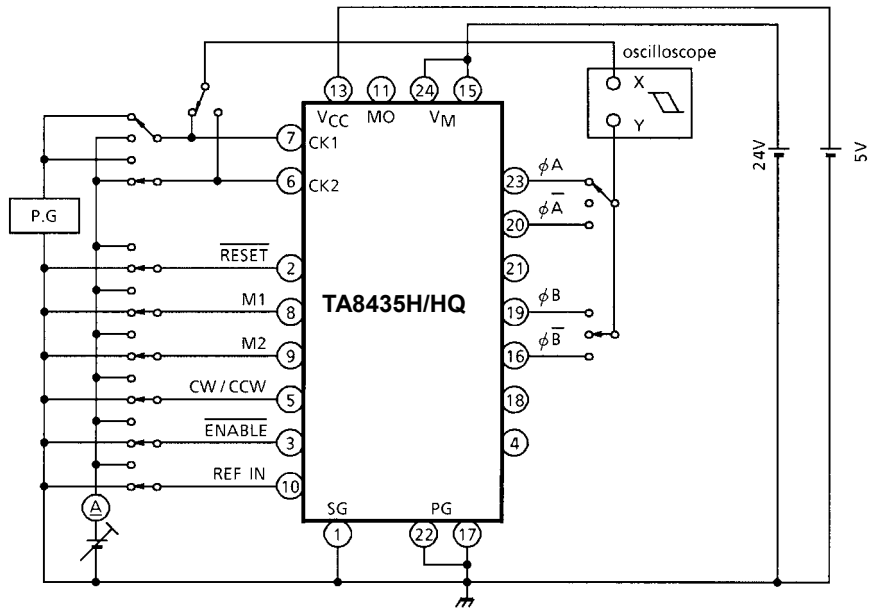

TEST CIRCUIT 2

I_{CC} , I_M

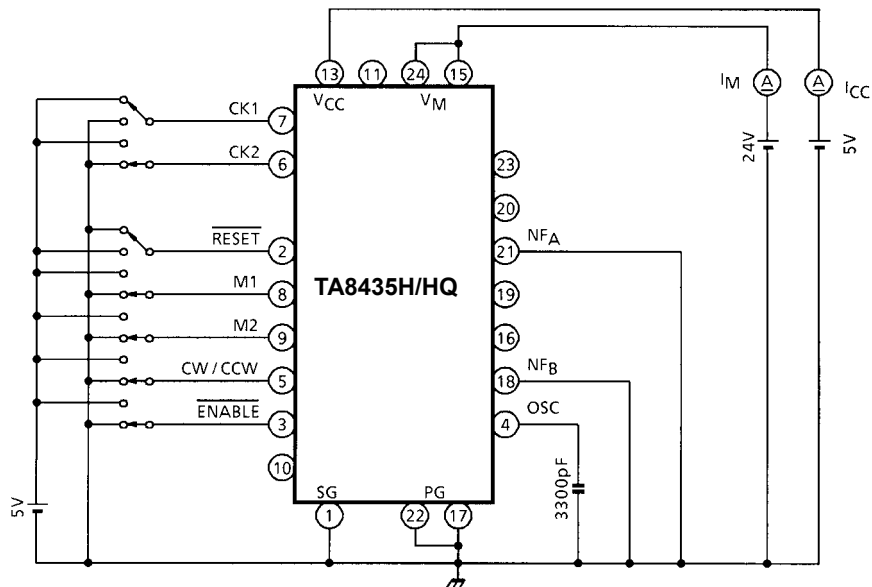

TEST CIRCUIT 3

$V_{NF}(H), (L)$

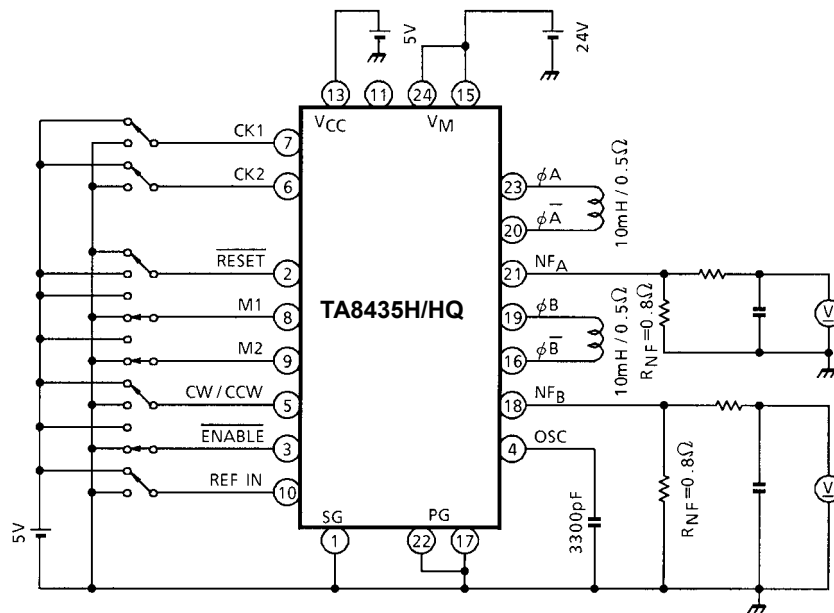

TEST CIRCUIT 4

$V_{CE(SAT)}$ UPPER SIDE, LOWER SIDE

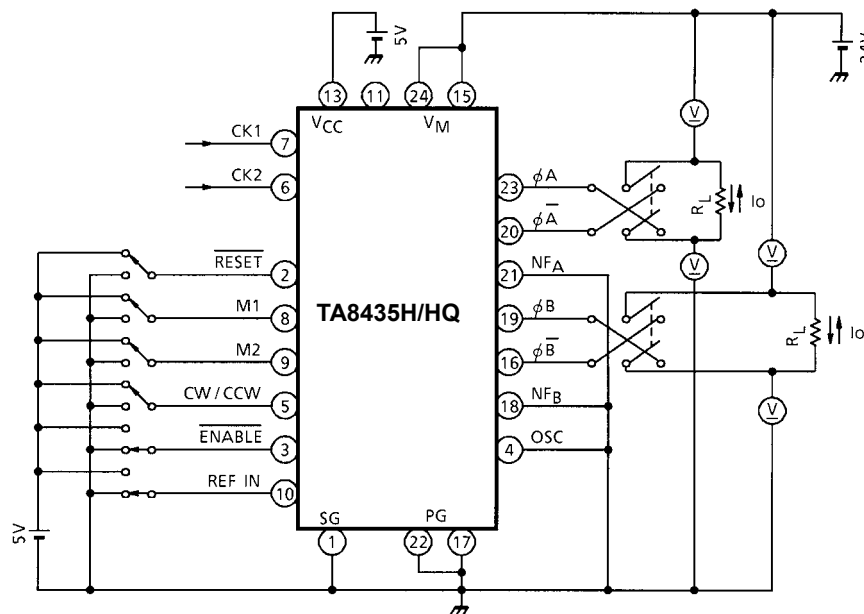

Note: Calibrate I_o to 1.5 A / 0.8 A by R_L

TEST CIRCUIT 5
 V_{FU} , V_{FL}

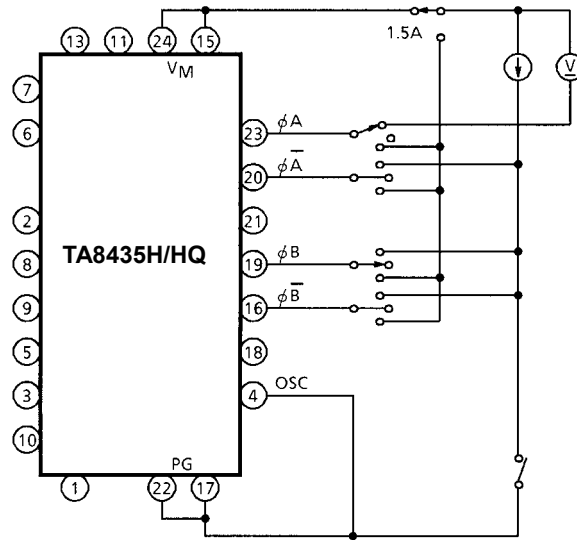

TEST CIRCUIT 6
 I_{OH} , I_{OL}

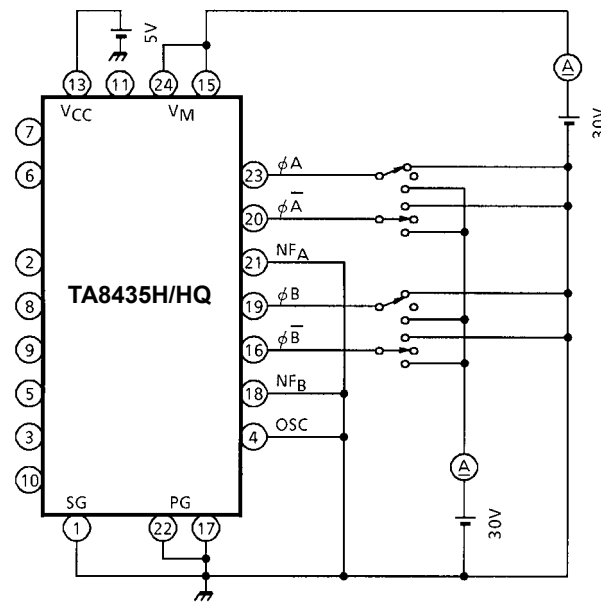

AC ELECTRICAL CHARACTERISTICS, MEASUREMENT WAVE CK (OSC)-OUT

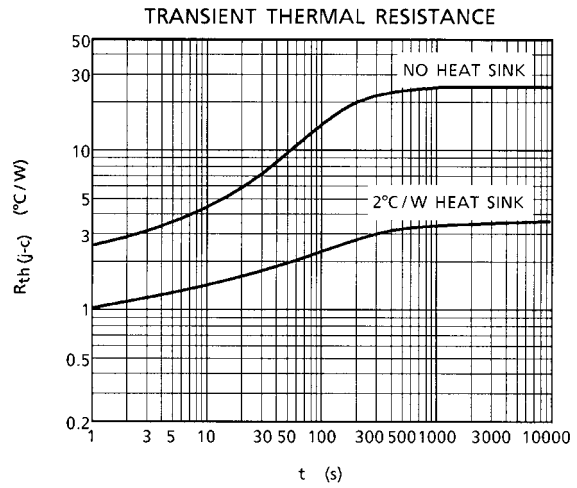
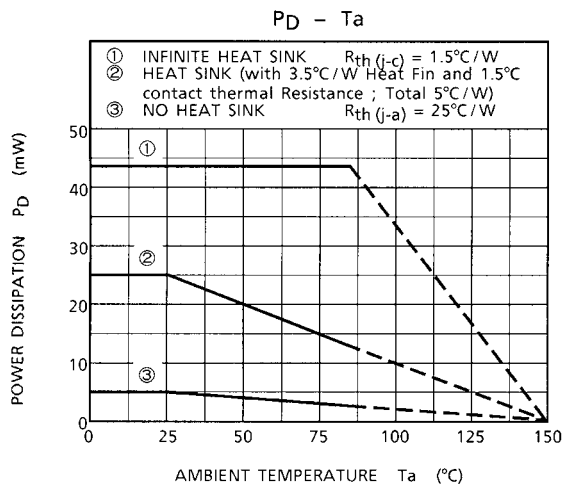
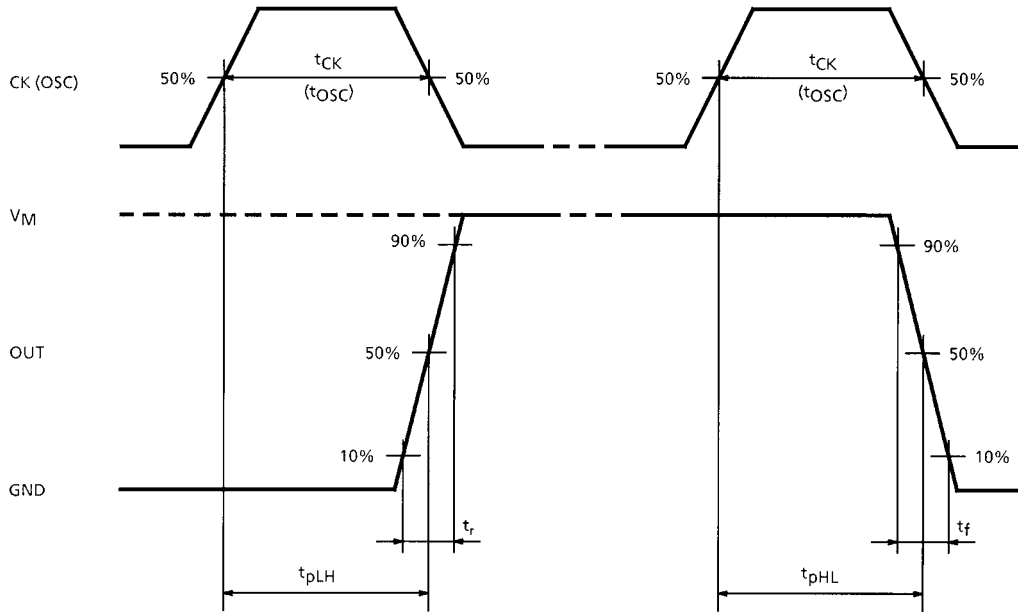

OUTPUT CURRENT VECTOR ORBIT (normalized to 90° per step)

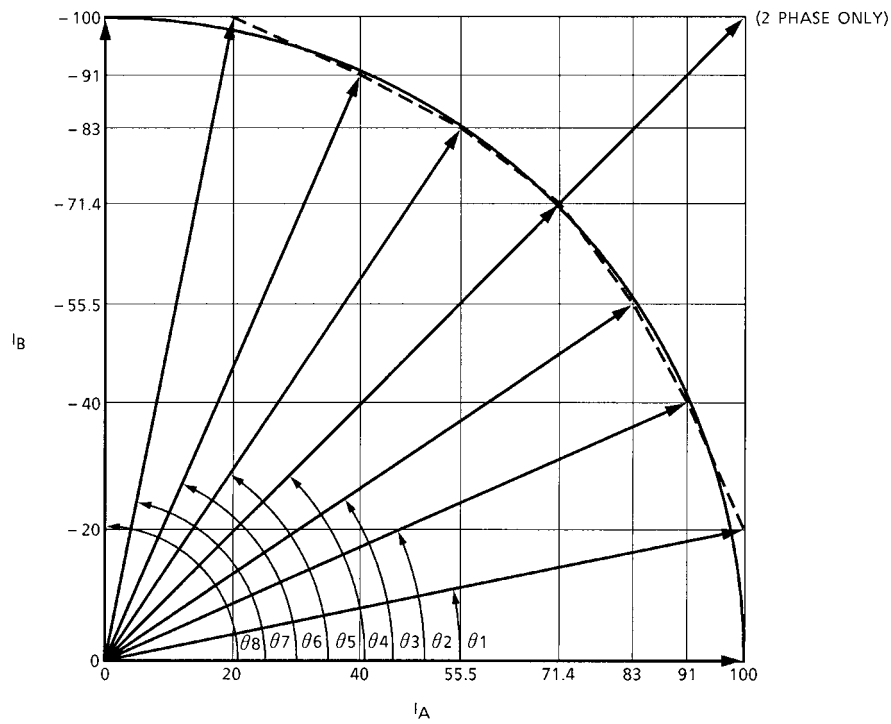

θ	ROTATION ANGLE		VECTOR LENGTH		
	IDEAL	TA8435H/HQ	IDEAL	TA8435H/HQ	
θ0	0°	0°	100	100.00	—
θ1	11.25°	11.31°	100	101.98	—
θ2	22.5°	23.73°	100	99.40	—
θ3	33.75°	33.77°	100	99.85	—
θ4	45°	45°	100	100.97	141.42
θ5	56.25°	56.23°	100	99.85	—
θ6	67.5°	66.27°	100	99.40	—
θ7	78.75°	78.69°	100	101.98	—
θ8	90°	90°	100	100.00	—
				1-2 / W1-2 / 2W1-2-Phase	2-Phase

APPLICATION CIRCUIT

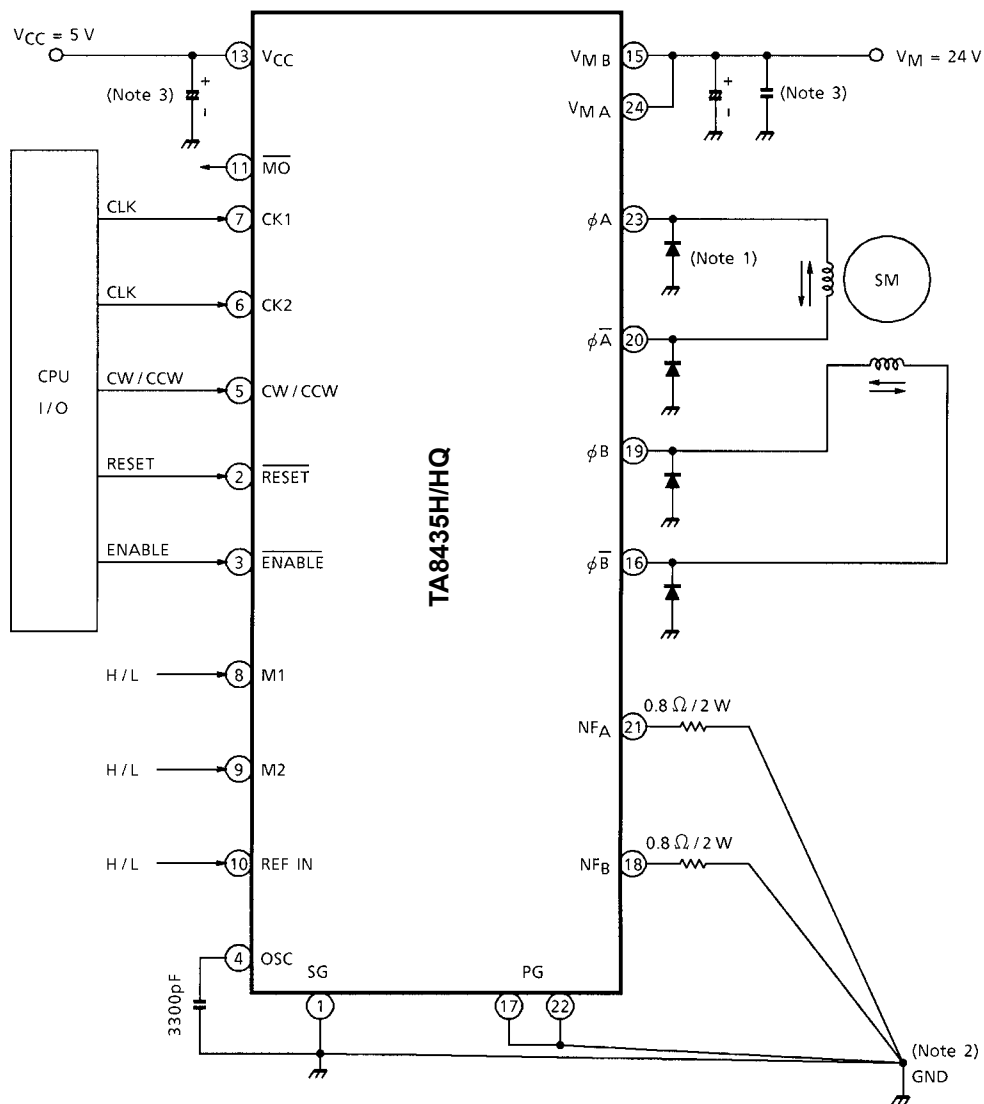

Note 1: A Schottky diode (3GWJ42) for preventing punch-through current should also be connected between each output (pin 16 / 19 / 20 / 23).

Note 2: The GND pattern should be laid out at one point to prevent common impedance.

Note 3: A capacitor for noise suppression should be connected between the power supply (V_{CC} , V_M) and GND to stabilize operation.

Note 4: Utmost care is necessary in the design of the output, V_M and GND lines since the IC may be destroyed by short-circuiting between outputs, air contamination faults, or faults due to improper grounding.

When using TA8435H/HQ

0. Introduction

The TA8435H/HQ controls the PWM to set the stepping motor winding current to a constant current. The device is a micro-step driver IC used to drive the stepping motor efficiently at low vibration.

1. Micro-step drive

The TA8435H/HQ drives the stepping motor in micro steps with a maximum resolution of 1/8 of the 2-phase stepping angle (in 2W1-2-phase mode).

In micro step operation, A-phase and B-phase current levels are set inside the IC so that the composite vector size and the rotation angle are even. Just inputting clock signals rotates the stepping motor in micro steps.

2. PWM control and output current setting

(1) Output current path (PWM control)

The TA8435H/HQ controls the PWM by turning the upper power transistor on and off. Here, current flows as shown in the figure below.

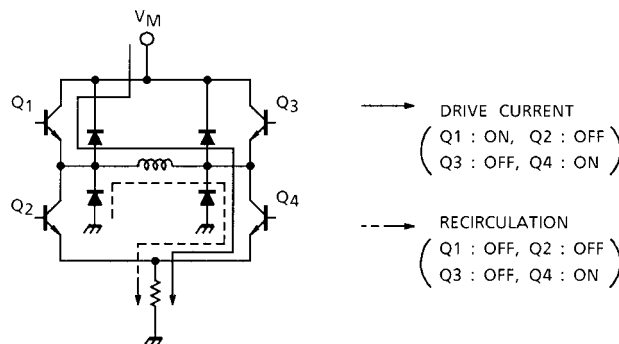

(2) Setting of output current by REF-IN input and current detection resistor

The motor current (maximum current for micro-step drive) I_O is set as shown in the following equation, using REF-IN input and the external current detection resistor R_{NF} .

$$I_O = V_{REF} / R_{NF}$$

where,

$$\text{REF-IN} = \text{High}, \quad V_{REF} = 0.8 \text{ V}$$

$$\text{REF-IN} = \text{Low}, \quad V_{REF} = 0.5 \text{ V}$$

3. Logic control

(1) Clock input for rotation direction control

To switch rotation between forward and reverse, there are two types of clock input: one-clock input and two-clock input.

(a) One-clock input

One clock pin, CK1 or CK2, is used for clock input. In this case, rotation is switched between forward or reverse using a CW or CCW signal.

<Input signal example: 1-2-phase mode>

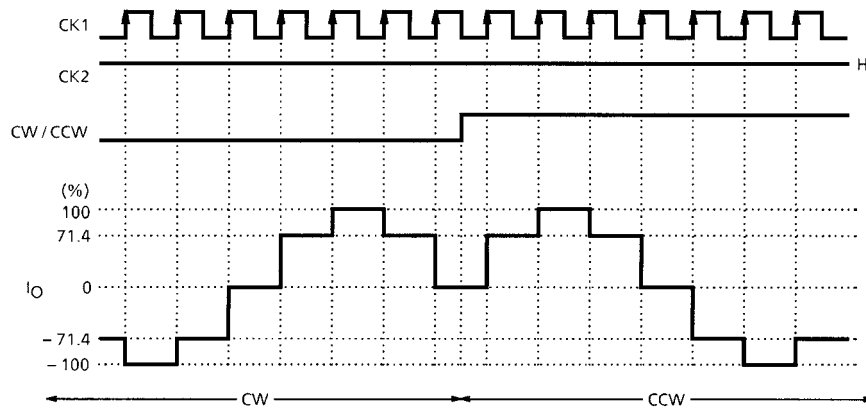

(b) Two-clock input

Both clock pins, CK1 and CK2, are used for clock input. Switching between CK1 and CK2 controls forward and reverse rotation.

<Input signal example: 1-2-phase mode>

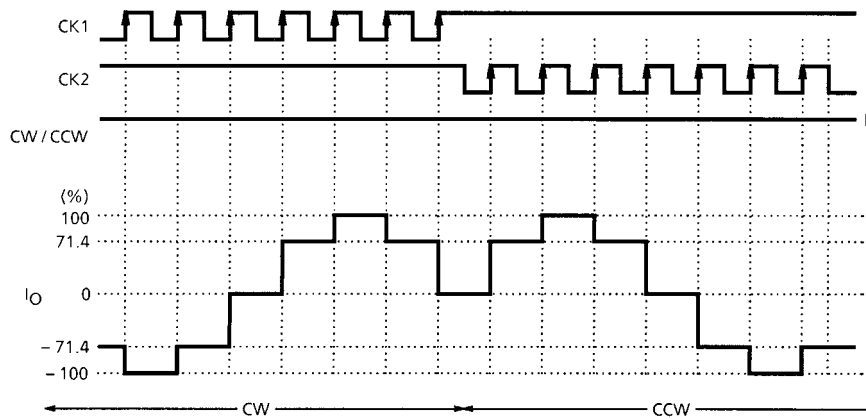

- (2) Mode setting
Setting M1 and M2 selects one of the following modes: 2-phase, 1-2-phase, W1-2-phase, and 2W1-2-phase modes.
- (3) Monitor (\overline{MO}) output
The product supports the use of monitor output to monitor the current waveform location.
For 2-phase mode, the \overline{MO} output is Low if the timing of the A-phase current = 100% and that of the B-phase current = -100%.
For 1-2-phase, W1-2-phase, or 2W1-2-phase mode, the \overline{MO} output is Low if the timing of the A-phase current = 100% and that of the B-phase current = 0%.
- (4) Reset pin
The product supports the use of reset input to reset the internal counter.
Setting RESET to Low resets the internal counter, forcing the output current to the same value as that when the \overline{MO} output is Low.
- (5) Phase mode switching
To avoid step changing during motor rotation, the current must not fluctuate at phase mode switching. Pay attention to the following points.
 - (a) During switching between 2-phase and other phase modes, the current fluctuates.
 - (b) When switching between phase modes other than 2-phase, the current can be switched without fluctuation if the timing of \overline{MO} output = Low.
However, when switching as follows, set RESET to Low beforehand:
from 1-2-phase to W1-2-phase or 2W1-2-phase mode;
from W1-2-phase to 2W1-2-phase mode.

<Example of Input Signal>

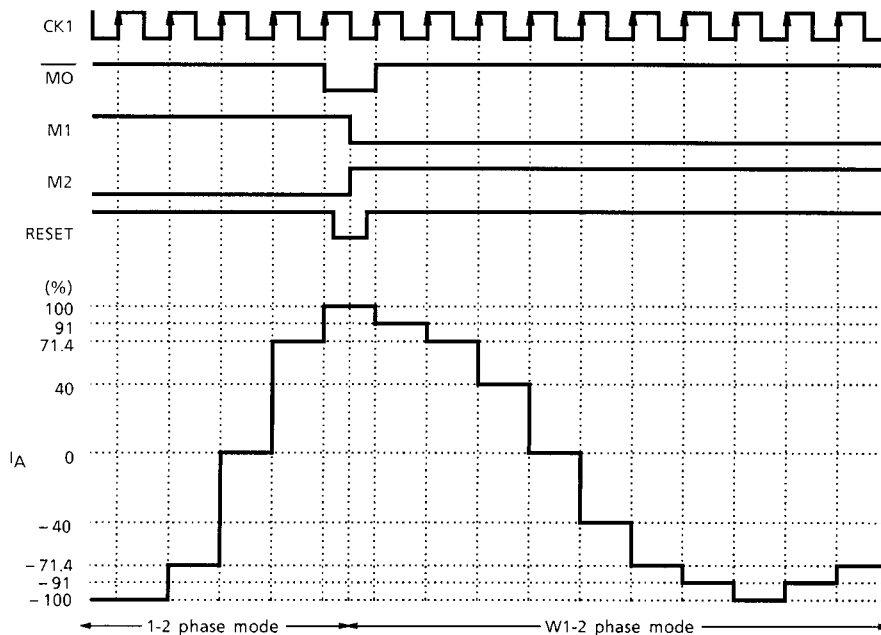

4. PWM oscillation frequency (external capacitor setting)

An external capacitor connected to the OSC pin is used to generate internally a sawtooth waveform. PWM is controlled using this frequency.

Toshiba recommend 3300 pF for the capacitance, taking variations between ICs into consideration.

5. External Schottky diode

A parasitic diode can be supported on the lower side of the output. When PWM is controlled, current flows to this parasitic diode. Unfortunately, this current has the effect of generating punch-through current and micro-step waveform fluctuation. For this reason, be sure to connect a Schottky barrier diode externally.

This external diode can also reduce heat generated in the IC.

6. Power dissipation

The IC power dissipation is determined by the following equation (where the Schottky diode is connected between the output pin and GND):

$$P = V_{CC} \times I_{CC} + V_M \times I_M + I_O (t_{ON} \times V_{SAT-U} + V_{SAT-L})$$

$$t_{ON} = T_{ON} / T_S \text{ (PWM control ON duty).}$$

The higher the ambient temperature, the smaller the power dissipation.

Check the P_D - T_a curve, and be sure to design the heat dissipation with a sufficient margin.

7. Heatsink fin processing

The IC fin (rear) is electrically connected to the rear of the chip.

When current flows to the fin, the IC malfunctions.

If there is any possibility of a voltage being generated between the IC GND and the fin, either ground the fin or insulate it.

PACKAGE DIMENSIONS

HZIP25-P-1.27

Unit: mm

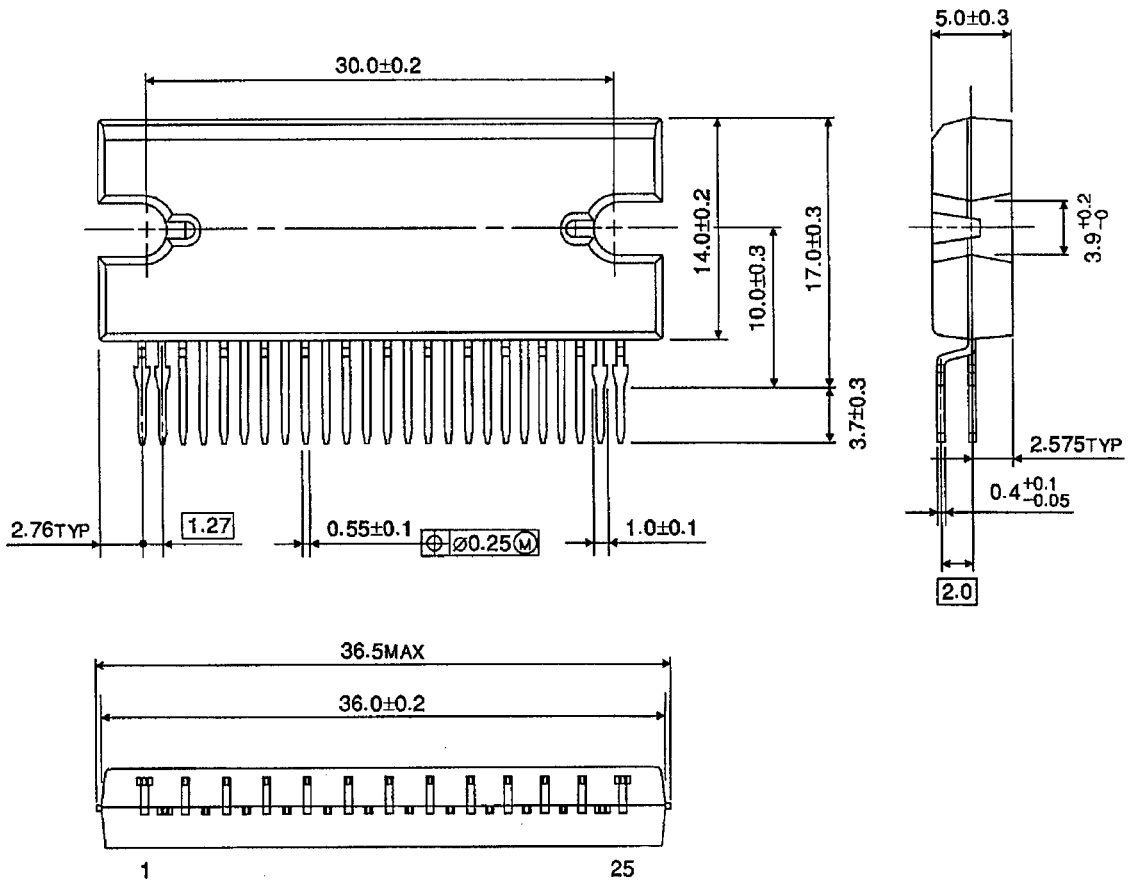

Weight: 9.86 g (typ.)

Notes on contents

1. Block Diagrams

Some of the functional blocks, circuits, or constants in the block diagram may be omitted or simplified for explanatory purposes.

2. Equivalent Circuits

The equivalent circuit diagrams may be simplified or some parts of them may be omitted for explanatory purposes.

3. Timing Charts

Timing charts may be simplified for explanatory purposes.

4. Maximum Ratings

The absolute maximum ratings of a semiconductor device are a set of specified parameter values that must not be exceeded during operation, even for an instant.

If any of these ratings are exceeded during operation, the electrical characteristics of the device may be irreparably altered, in which case the reliability and lifetime of the device can no longer be guaranteed.

Moreover, any exceeding of the ratings during operation may cause breakdown, damage and/or degradation in other equipment. Applications using the device should be designed so that no maximum rating will ever be exceeded under any operating conditions.

Before using, creating and/or producing designs, refer to and comply with the precautions and conditions set forth in this document.

5. Application Circuits

The application circuits shown in this document are provided for reference purposes only. Thorough evaluation is required in the mass production design phase.

In furnishing these examples of application circuits, Toshiba does not grant the use of any industrial property rights.

6. Test Circuits

Components in test circuits are used only to obtain and confirm device characteristics. These components and circuits are not guaranteed to prevent malfunction or failure in application equipment.

Handling of the IC

Ensure that the product is installed correctly to prevent breakdown, damage and/or degradation in the product or equipment.

Over-current protection and heat protection circuits

These protection functions are intended only as a temporary means of preventing output short circuits or other abnormal conditions and are not guaranteed to prevent damage to the IC.

If the guaranteed operating ranges of this product are exceeded, these protection features may not operate and some output short circuits may result in the IC being damaged.

The over-current protection feature is intended to protect the IC from temporary short circuits only.

Short circuits persisting over long periods may cause excessive stress and damage the IC. Systems should be configured so that any over-current condition will be eliminated as soon as possible.

Counter-electromotive force

When the motor reverses or stops, the effect of counter-electromotive force may cause the current to flow to the power source.

If the power supply is not equipped with sink capability, the power and output pins may exceed the maximum rating.

The counter-electromotive force of the motor will vary depending on the conditions of use and the features of the motor. Therefore make sure there will be no damage to or operational problem in the IC, and no damage to or operational errors in peripheral circuits caused by counter-electromotive force.

RESTRICTIONS ON PRODUCT USE

000707EBA

- TOSHIBA is continually working to improve the quality and reliability of its products. Nevertheless, semiconductor devices in general can malfunction or fail due to their inherent electrical sensitivity and vulnerability to physical stress. It is the responsibility of the buyer, when utilizing TOSHIBA products, to comply with the standards of safety in making a safe design for the entire system, and to avoid situations in which a malfunction or failure of such TOSHIBA products could cause loss of human life, bodily injury or damage to property.
In developing your designs, please ensure that TOSHIBA products are used within specified operating ranges as set forth in the most recent TOSHIBA products specifications. Also, please keep in mind the precautions and conditions set forth in the "Handling Guide for Semiconductor Devices," or "TOSHIBA Semiconductor Reliability Handbook" etc..
- The TOSHIBA products listed in this document are intended for usage in general electronics applications (computer, personal equipment, office equipment, measuring equipment, industrial robotics, domestic appliances, etc.). These TOSHIBA products are neither intended nor warranted for usage in equipment that requires extraordinarily high quality and/or reliability or a malfunction or failure of which may cause loss of human life or bodily injury ("Unintended Usage"). Unintended Usage include atomic energy control instruments, airplane or spaceship instruments, transportation instruments, traffic signal instruments, combustion control instruments, medical instruments, all types of safety devices, etc.. Unintended Usage of TOSHIBA products listed in this document shall be made at the customer's own risk.
- The products described in this document are subject to the foreign exchange and foreign trade laws.
- The information contained herein is presented only as a guide for the applications of our products. No responsibility is assumed by TOSHIBA CORPORATION for any infringements of intellectual property or other rights of the third parties which may result from its use. No license is granted by implication or otherwise under any intellectual property or other rights of TOSHIBA CORPORATION or others.
- The information contained herein is subject to change without notice.