



STGP7NB60H

N-CHANNEL 7A - 600V TO-220 PowerMESH™ IGBT

TYPE	V _{CES}	V _{CE(sat)}	I _C
STGP7NB60H	600 V	< 2.8 V	7 A

- HIGH INPUT IMPEDANCE (VOLTAGE DRIVEN)
- LOW ON-VOLTAGE DROP (V_{cesat})
- LOW GATE CHARGE
- HIGH CURRENT CAPABILITY
- VERY HIGH FREQUENCY OPERATION
- OFF LOSSES INCLUDE TAIL CURRENT

DESCRIPTION

Using the latest high voltage technology based on a patented strip layout, STMicroelectronics has designed an advanced family of IGBTs, the PowerMESH™ IGBTs, with outstanding performances. The suffix "H" identifies a family optimized to achieve very low switching times for high frequency applications (<120kHz).

APPLICATIONS

- HIGH FREQUENCY MOTOR CONTROLS
- SMPS AND PFC IN BOTH HARD SWITCH AND RESONANT TOPOLOGIES

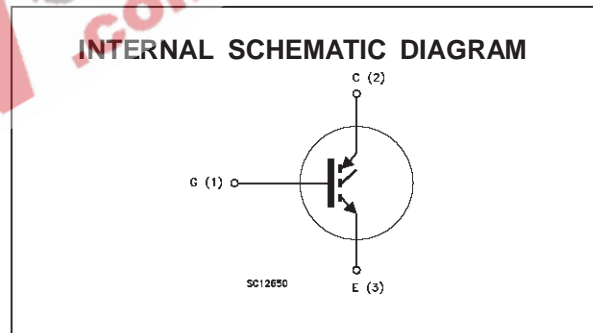
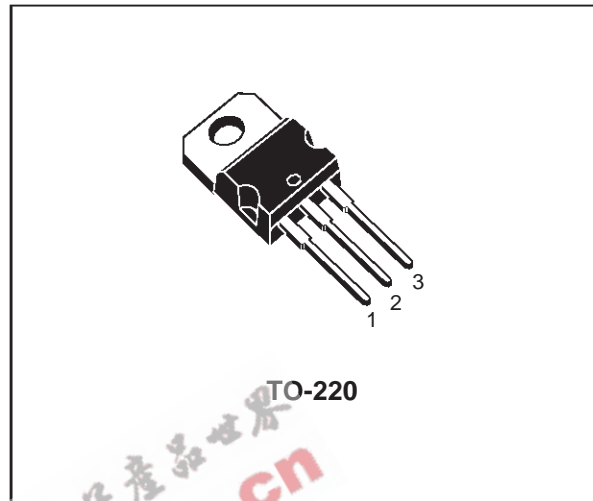

ABSOLUTE MAXIMUM RATINGS

Symbol	Parameter	Value	Unit
V _{CES}	Collector-Emitter Voltage (V _{GS} = 0)	600	V
V _{ECR}	Emitter-Collector Voltage	20	V
V _{GE}	Gate-Emitter Voltage	± 20	V
I _C	Collector Current (continuous) at T _c = 25 °C	14	A
I _C	Collector Current (continuous) at T _c = 100 °C	7	A
I _{CM} (•)	Collector Current (pulsed)	56	A
P _{tot}	Total Dissipation at T _c = 25 °C	80	W
	Derating Factor	0.64	W/°C
T _{stg}	Storage Temperature	-65 to 150	°C
T _j	Max. Operating Junction Temperature	150	°C

(•) Pulse width limited by safe operating area

STGP7NB60H

THERMAL DATA

R _{thj-case}	Thermal Resistance Junction-case	Max	1.56	°C/W
R _{thj-amb}	Thermal Resistance Junction-ambient	Max	62.5	°C/W
R _{thc-sink}	Thermal Resistance Case-sink	Typ	0.5	°C/W

ELECTRICAL CHARACTERISTICS (T_j = 25 °C unless otherwise specified)

OFF

Symbol	Parameter	Test Conditions	Min.	Typ.	Max.	Unit
V _{BR(CES)}	Collector-Emitter Breakdown Voltage	I _C = 250 μA V _{GE} = 0	600			V
I _{CES}	Collector cut-off (V _{GE} = 0)	V _{CE} = Max Rating T _j = 25 °C V _{CE} = Max Rating T _j = 125 °C			10 100	μA μA
I _{GES}	Gate-Emitter Leakage Current (V _{CE} = 0)	V _{GE} = ± 20 V V _{CE} = 0			± 100	nA

ON (*)

Symbol	Parameter	Test Conditions	Min.	Typ.	Max.	Unit
V _{GE(th)}	Gate Threshold Voltage	V _{CE} = V _{GE} I _C = 250 μA	3		5	V
V _{CE(SAT)}	Collector-Emitter Saturation Voltage	V _{GE} = 15 V I _C = 7 A V _{GE} = 15 V I _C = 7 A T _j = 125 °C		2.3 1.9	2.8	V V

DYNAMIC

Symbol	Parameter	Test Conditions	Min.	Typ.	Max.	Unit
g _{fs}	Forward Transconductance	V _{CE} = 25 V I _C = 7 A	3.5	5		S
C _{ies} C _{oes} C _{res}	Input Capacitance Output Capacitance Reverse Transfer Capacitance	V _{CE} = 25 V f = 1 MHz V _{GE} = 0	390 45 10	560 68 15	730 90 20	pF pF pF
Q _G Q _{GE} Q _{GC}	Total Gate Charge Gate-Emitter Charge Gate-Collector Charge	V _{CE} = 480 V I _C = 7 A V _{GE} = 15 V		42 7.9 17.6	55	nC nC nC
I _{CL}	Latching Current	V _{clamp} = 480 V R _G = 10Ω T _j = 150 °C	28			A

SWITCHING ON

Symbol	Parameter	Test Conditions	Min.	Typ.	Max.	Unit
t _{d(on)} t _r	Delay Time Rise Time	V _{CC} = 480 V I _C = 7 A V _{GE} = 15 V R _G = 10Ω		15 48		ns ns
(di/dt) _{on}	Turn-on Current Slope	V _{CC} = 480 V I _C = 7 A R _G = 10 Ω V _{GE} = 15 V		160		A/μs
E _{on}	Turn-on Switching Losses	T _j = 125 °C		70		μJ

ELECTRICAL CHARACTERISTICS (continued)

SWITCHING OFF

Symbol	Parameter	Test Conditions	Min.	Typ.	Max.	Unit
t_c	Cross-Over Time	$V_{CC} = 480\text{ V}$		85		ns
$t_r(V_{off})$	Off Voltage Rise Time	$I_C = 7\text{ A}$ $R_{GE} = 10\ \Omega$		20		ns
$t_d(off)$	Delay Time	$V_{GE} = 15\text{ V}$		75		ns
t_f	Fall Time			70		ns
$E_{off(**)}$	Turn-off Switching Loss			85		μJ
E_{ts}	Total Switching Loss			130		μJ
t_c	Cross-Over Time	$V_{CC} = 480\text{ V}$		150		ns
$t_r(V_{off})$	Off Voltage Rise Time	$I_C = 7\text{ A}$ $R_{GE} = 10\ \Omega$		50		ns
$t_d(off)$	Delay Time	$V_{GE} = 15\text{ V}$ $T_j = 125\text{ }^\circ\text{C}$		110		ns
t_f	Fall Time			110		ns
$E_{off(**)}$	Turn-off Switching Loss			220		μJ
E_{ts}	Total Switching Loss			290		μJ

(*) Pulse width limited by max. junction temperature
 (*) Pulsed: Pulse duration = 300 μs , duty cycle 1.5 %
 (**) Losses Include Also The Tail (Jedec Standardization)



Thermal Impedance

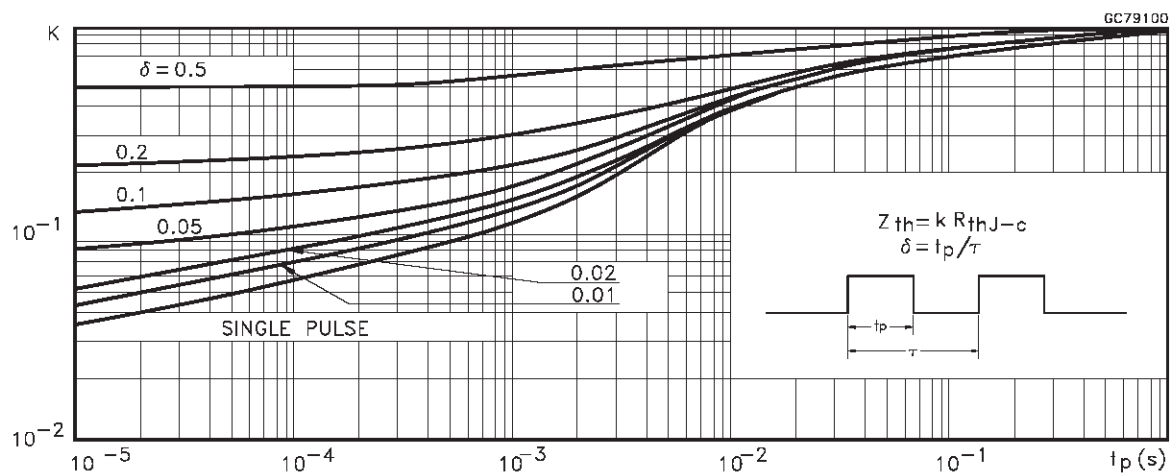

Output Characteristics

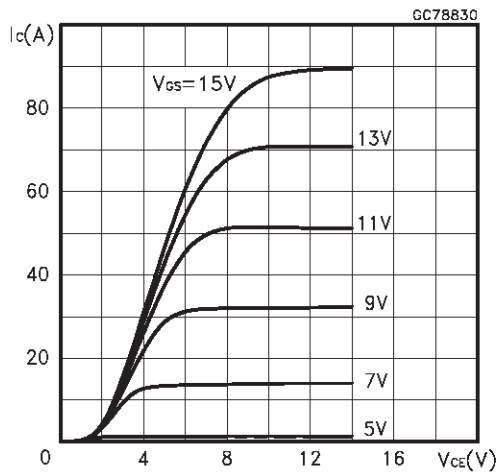

Transfer Characteristics

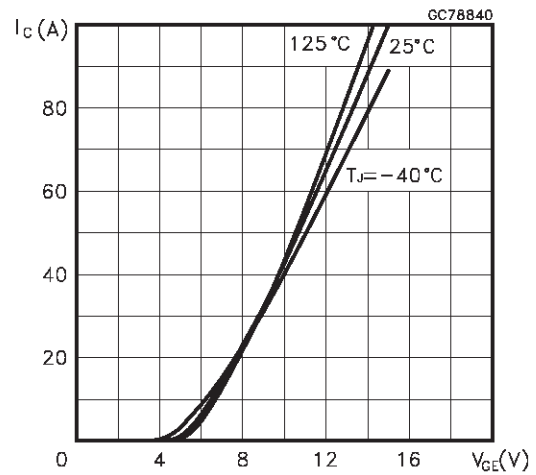

Transconductance

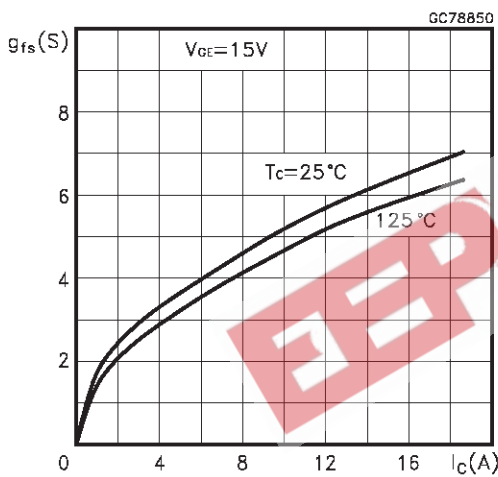

Collector-Emitter On Voltage vs Temperature

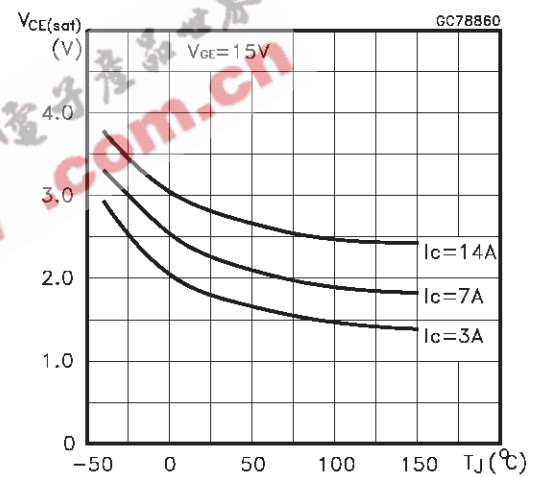

Collector-Emitter On Voltage vs Collector Current

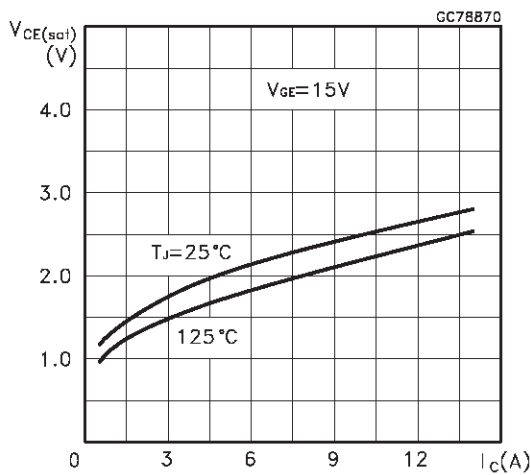

Gate Threshold vs Temperature

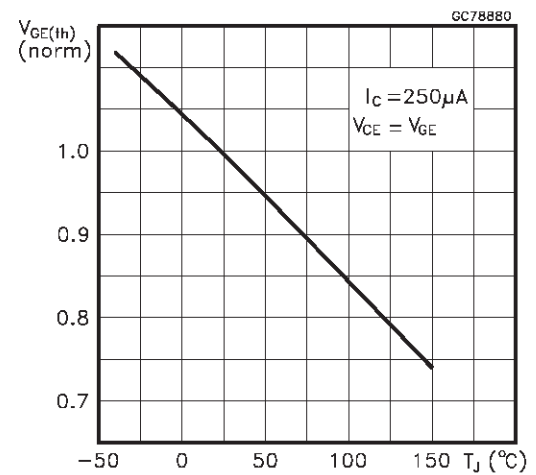

Normalized Breakdown Voltage vs Temperature

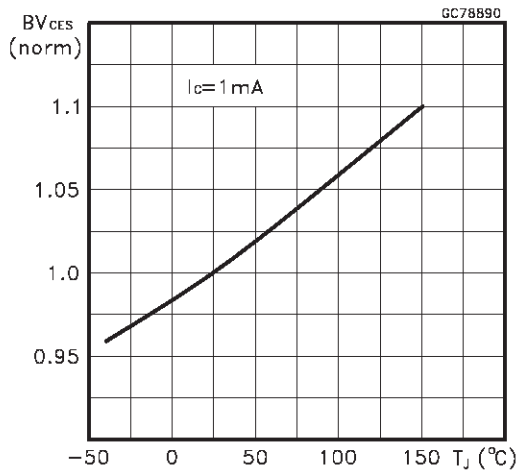

Capacitance Variations

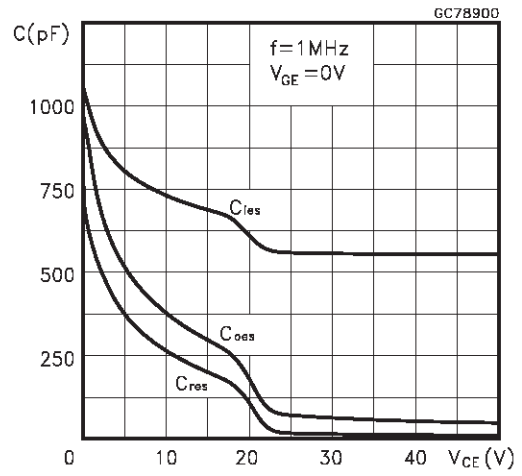

Gate Charge vs Gate-Emitter Voltage

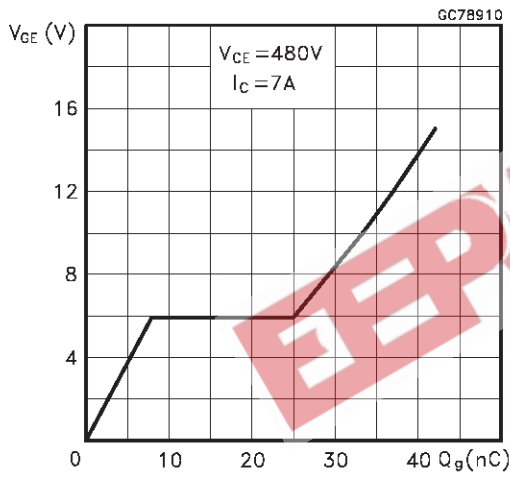

Total Switching Losses vs Gate Resistance

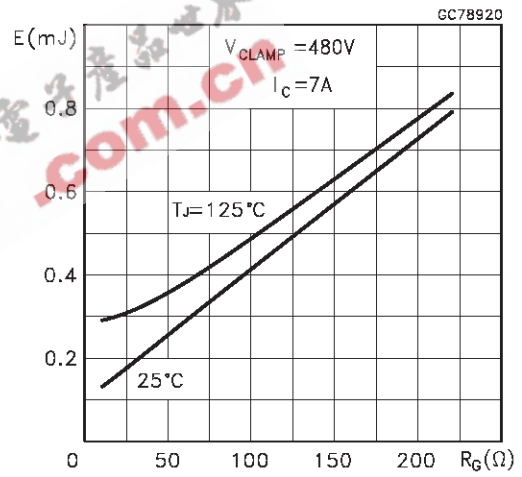

Total Switching Losses vs Temperature

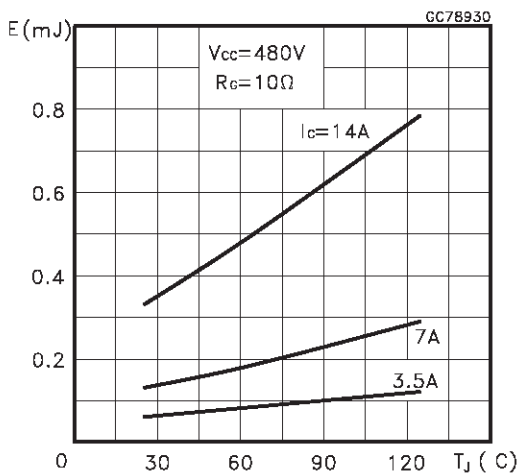

Total Switching Losses vs Collector Current

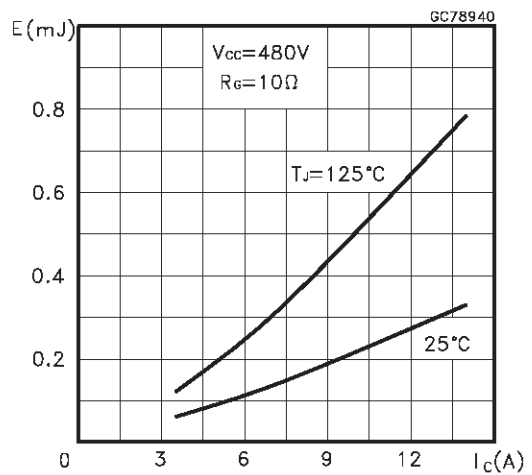

Switching Off Safe Operating Area

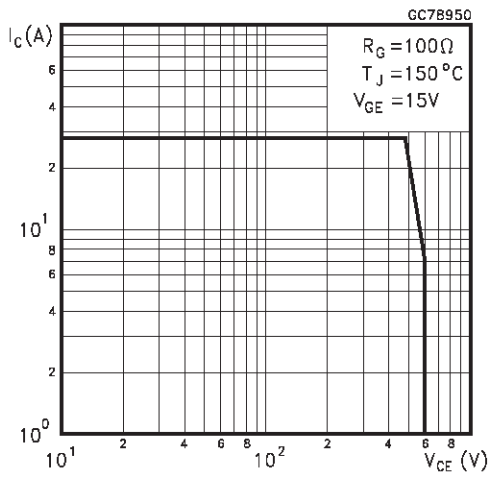

Fig. 1: Gate Charge test Circuit

Fig. 2: Test Circuit For Inductive Load Switching

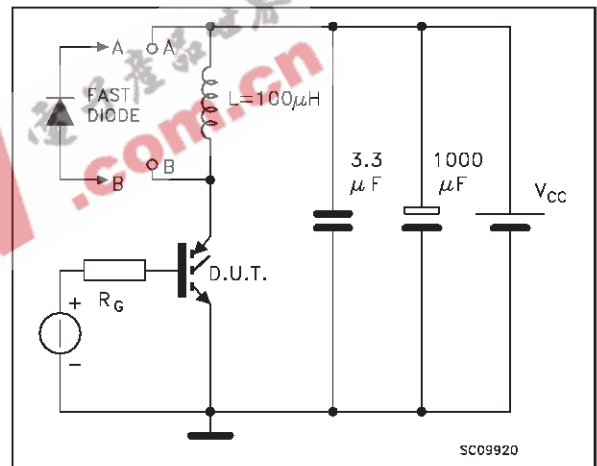
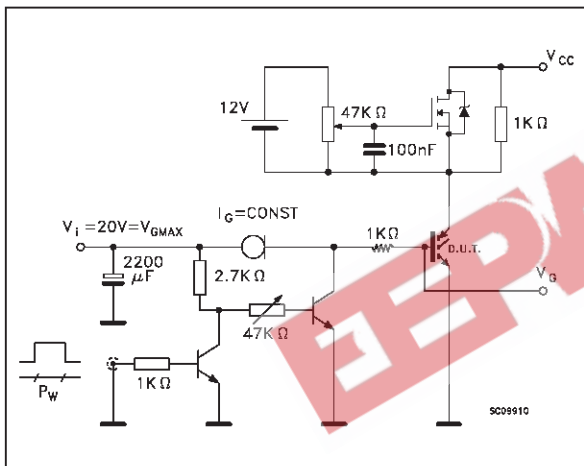
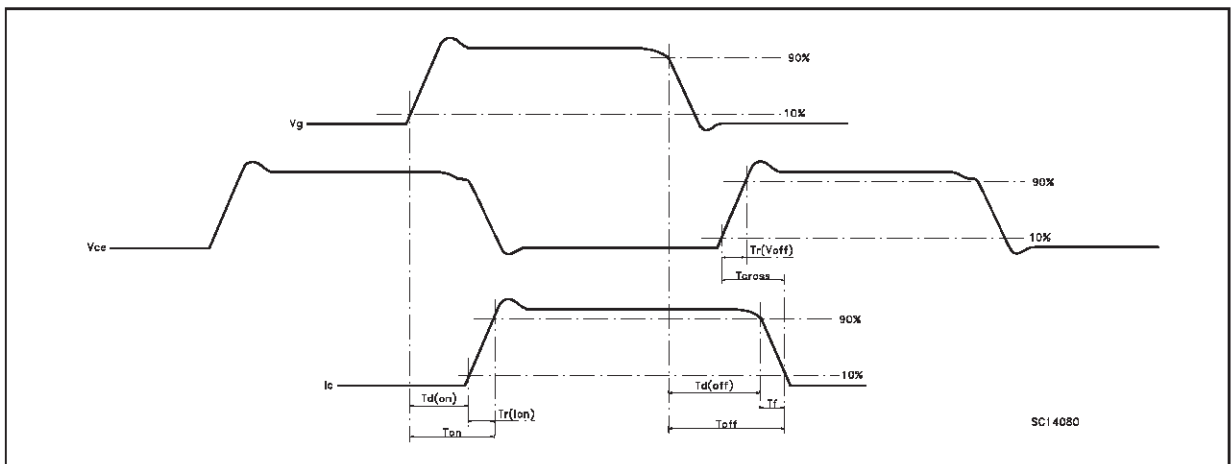
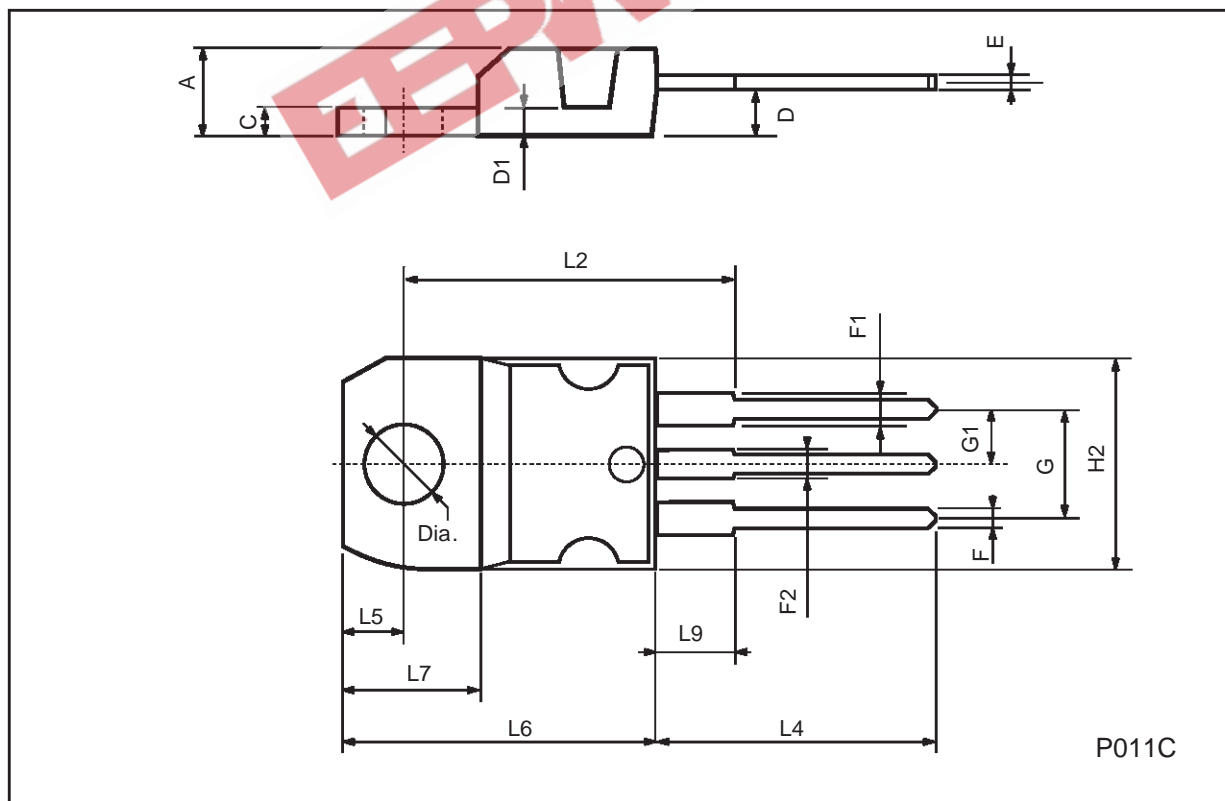

Fig. 3: Switching Waveforms



TO-220 MECHANICAL DATA

DIM.	mm			inch		
	MIN.	TYP.	MAX.	MIN.	TYP.	MAX.
A	4.40		4.60	0.173		0.181
C	1.23		1.32	0.048		0.051
D	2.40		2.72	0.094		0.107
D1		1.27			0.050	
E	0.49		0.70	0.019		0.027
F	0.61		0.88	0.024		0.034
F1	1.14		1.70	0.044		0.067
F2	1.14		1.70	0.044		0.067
G	4.95		5.15	0.194		0.203
G1	2.4		2.7	0.094		0.106
H2	10.0		10.40	0.393		0.409
L2		16.4			0.645	
L4	13.0		14.0	0.511		0.551
L5	2.65		2.95	0.104		0.116
L6	15.25		15.75	0.600		0.620
L7	6.2		6.6	0.244		0.260
L9	3.5		3.93	0.137		0.154
DIA.	3.75		3.85	0.147		0.151



EEPW 电子产品世界
.com.cn

Information furnished is believed to be accurate and reliable. However, STMicroelectronics assumes no responsibility for the consequences of use of such information nor for any infringement of patents or other rights of third parties which may result from its use. No license is granted by implication or otherwise under any patent or patent rights of STMicroelectronics. Specification mentioned in this publication are subject to change without notice. This publication supersedes and replaces all information previously supplied. STMicroelectronics products are not authorized for use as critical components in life support devices or systems without express written approval of STMicroelectronics.

The ST logo is a trademark of STMicroelectronics

© 1999 STMicroelectronics – Printed in Italy – All Rights Reserved
STMicroelectronics GROUP OF COMPANIES

Australia - Brazil - China - Finland - France - Germany - Hong Kong - India - Italy - Japan - Malaysia - Malta - Morocco -
Singapore - Spain - Sweden - Switzerland - United Kingdom - U.S.A.