



**MOTOROLA**

# OCTAL BUFFER/LINE DRIVER WITH 3-STATE OUTPUTS

The SN54/74LS240, 241 and 244 are Octal Buffers and Line Drivers designed to be employed as memory address drivers, clock drivers and bus-oriented transmitters/receivers which provide improved PC board density.

- Hysteresis at Inputs to Improve Noise Margins
- 3-State Outputs Drive Bus Lines or Buffer Memory Address Registers
- Input Clamp Diodes Limit High-Speed Termination Effects

**SN54/74LS240**  
**SN54/74LS241**  
**SN54/74LS244**

**OCTAL BUFFER/LINE DRIVER WITH 3-STATE OUTPUTS**  
**LOW POWER SCHOTTKY**

## LOGIC AND CONNECTION DIAGRAMS DIP (TOP VIEW)

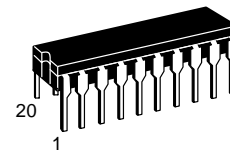
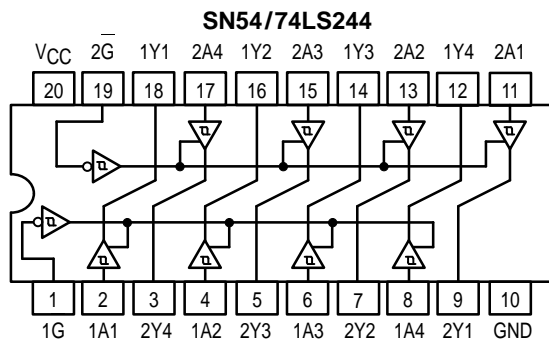
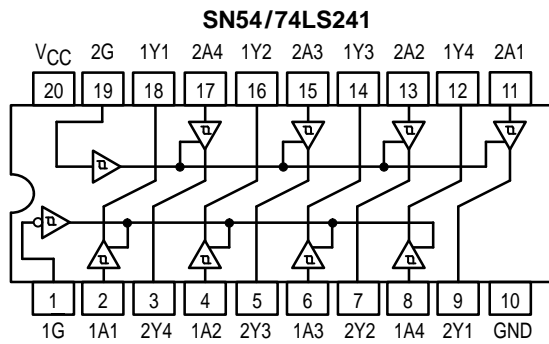
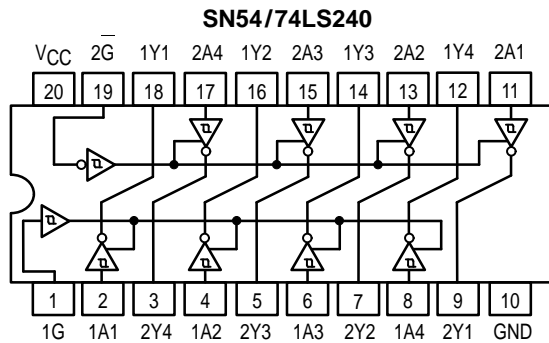

**J SUFFIX**  
**CERAMIC**  
**CASE 732-03**

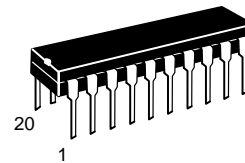

**N SUFFIX**  
**PLASTIC**  
**CASE 738-03**

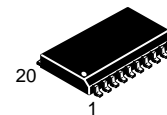

**DW SUFFIX**  
**SOIC**  
**CASE 751D-03**

## ORDERING INFORMATION

SN54LSXXXJ Ceramic  
 SN74LSXXXN Plastic  
 SN74LSXXXDW SOIC

# SN54/74LS240 • SN54/74LS241 • SN54/74LS244

## TRUTH TABLES

SN54/74LS240

INPUTS		OUTPUT
1G, 2G	D	
L	L	H
L	H	L
H	X	(Z)

SN54/74LS244

INPUTS		OUTPUT
1G, 2G	D	
L	L	L
L	H	H
H	X	(Z)

SN54/74LS241

INPUTS		OUTPUT	INPUTS		OUTPUT
1G	D		2G	D	
L	L	L	H	L	L
L	H	H	H	H	H
H	X	(Z)	L	X	(Z)

H = HIGH Voltage Level  
 L = LOW Voltage Level  
 X = Immaterial  
 Z = HIGH Impedance

## GUARANTEED OPERATING RANGES

Symbol	Parameter		Min	Typ	Max	Unit
V <sub>CC</sub>	Supply Voltage	54	4.5	5.0	5.5	V
		74	4.75	5.0	5.25	
T <sub>A</sub>	Operating Ambient Temperature Range	54	-55	25	125	°C
		74	0	25	70	
I <sub>OH</sub>	Output Current — High	54, 74			-3.0	mA
		54 74			-12 -15	mA
I <sub>OL</sub>	Output Current — Low	54			12	mA
		74			24	

# SN54/74LS240 • SN54/74LS241 • SN54/74LS244

## DC CHARACTERISTICS OVER OPERATING TEMPERATURE RANGE (unless otherwise specified)

Symbol	Parameter		Limits			Unit	Test Conditions
			Min	Typ	Max		
V <sub>IH</sub>	Input HIGH Voltage		2.0			V	Guaranteed Input HIGH Voltage for All Inputs
V <sub>IL</sub>	Input LOW Voltage	54			0.7	V	Guaranteed Input LOW Voltage for All Inputs
		74			0.8		
V <sub>T+</sub> -V <sub>T-</sub>	Hysteresis		0.2	0.4		V	V <sub>CC</sub> = MIN
V <sub>IK</sub>	Input Clamp Diode Voltage			-0.65	-1.5	V	V <sub>CC</sub> = MIN, I <sub>IN</sub> = -18 mA
V <sub>OH</sub>	Output HIGH Voltage	54, 74	2.4	3.4		V	V <sub>CC</sub> = MIN, I <sub>OH</sub> = -3.0 mA
		54, 74	2.0			V	V <sub>CC</sub> = MIN, I <sub>OH</sub> = MAX
V <sub>OL</sub>	Output LOW Voltage	54, 74		0.25	0.4	V	I <sub>OL</sub> = 12 mA
		74		0.35	0.5	V	I <sub>OL</sub> = 24 mA
I <sub>OZH</sub>	Output Off Current HIGH				20	μA	V <sub>CC</sub> = MAX, V <sub>OUT</sub> = 2.7 V
I <sub>OZL</sub>	Output Off Current LOW				-20	μA	V <sub>CC</sub> = MAX, V <sub>OUT</sub> = 0.4 V
I <sub>IH</sub>	Input HIGH Current				20	μA	V <sub>CC</sub> = MAX, V <sub>IN</sub> = 2.7 V
					0.1	mA	V <sub>CC</sub> = MAX, V <sub>IN</sub> = 7.0 V
I <sub>IL</sub>	Input LOW Current				-0.2	mA	V <sub>CC</sub> = MAX, V <sub>IN</sub> = 0.4 V
I <sub>OS</sub>	Output Short Circuit Current (Note 1)		-40		-225	mA	V <sub>CC</sub> = MAX
I <sub>CC</sub>	Power Supply Current Total, Output HIGH				27	mA	V <sub>CC</sub> = MAX
	Total, Output LOW	LS240			44		
		LS241/244			46		
	Total at HIGH Z	LS240			50		
		LS241/244			54		

Note 1: Not more than one output should be shorted at a time, nor for more than 1 second.

## AC CHARACTERISTICS (T<sub>A</sub> = 25°C, V<sub>CC</sub> = 5.0 V)

Symbol	Parameter		Limits			Unit	Test Conditions
			Min	Typ	Max		
t <sub>PLH</sub> t <sub>PHL</sub>	Propagation Delay, Data to Output LS240			9.0 12	14 18	ns	C <sub>L</sub> = 45 pF, R <sub>L</sub> = 667 Ω
t <sub>PLH</sub> t <sub>PHL</sub>	Propagation Delay, Data to Output LS241/244			12 12	18 18	ns	
t <sub>PZH</sub>	Output Enable Time to HIGH Level			15	23	ns	
t <sub>PZL</sub>	Output Enable Time to LOW Level			20	30	ns	
t <sub>PLZ</sub> t <sub>PHZ</sub>	Output Disable Time from LOW Level Output Disable Time from HIGH Level			15 10	25 18	ns	

# SN54/74LS240 • SN54/74LS241 • SN54/74LS244

## AC WAVEFORMS

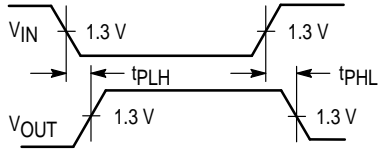

Figure 1

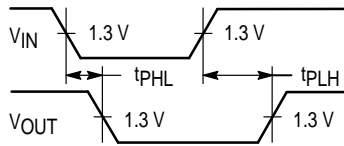

Figure 2

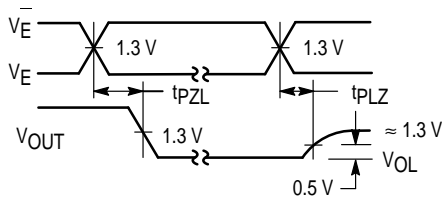

Figure 3

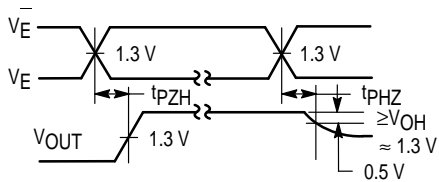
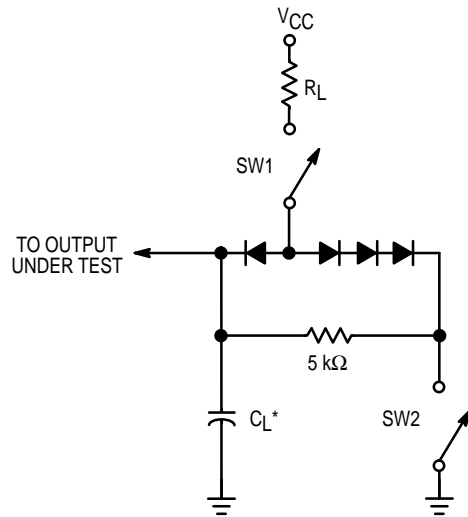

Figure 4



SWITCH POSITIONS

SYMBOL	SW1	SW2
t <sub>PZH</sub>	Open	Closed
t <sub>PZL</sub>	Closed	Open
t <sub>PLZ</sub>	Closed	Closed
t <sub>PHZ</sub>	Closed	Closed

Figure 5