

SN54154, SN74154 4-LINE TO 16-LINE DECODERS/DEMULTIPLEXERS

SDLS056

DECEMBER 1972 — REVISED MARCH 88

- '154 is Ideal for High-Performance Memory Decoding
- Decodes 4 Binary-Coded Inputs into One of 16 Mutually Exclusive Outputs
- Performs the Demultiplexing Function by Distributing Data From One Input Line to Any One of 16 Outputs
- Input Clamping Diodes Simplify System Design
- High Fan-Out, Low-Impedance, Totem-Pole Outputs
- Fully Compatible with Most TTL and MSI Circuits

SN54154 . . . J OR W PACKAGE
SN74154 . . . N PACKAGE

(TOP VIEW)

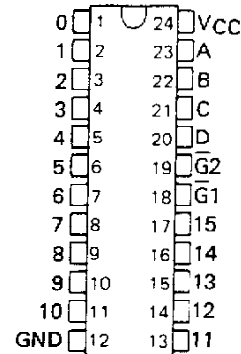

| TYPICAL AVERAGE PROPAGATION DELAY 3 LEVELS OF LOGIC | | TYPICAL POWER DISSIPATION |
|---|-------|------------------------------|
| 23 ns | 19 ns | 170 mW |

logic symbols (alternatives)[†]

description

Each of these monolithic, 4-line-to-16-line decoders utilizes TTL circuitry to decode four binary-coded inputs into one of sixteen mutually exclusive outputs when both the strobe inputs, $\overline{G1}$ and $\overline{G2}$, are low. The demultiplexing function is performed by using the 4 input lines to address the output line, passing data from one of the strobe inputs with the other strobe input low. When either strobe input is high, all outputs are high. These demultiplexers are ideally suited for implementing high-performance memory decoders. For ultra-high speed systems, SN54S138/SN74S138 and SN54S139/SN74S139 are recommended.

These circuits are fully compatible for use with most other TTL circuits. All inputs are buffered and input clamping diodes are provided to minimize transmission-line effects and thereby simplify system design.

The SN54154 is characterized for operation over the full military temperature range of -55°C to 125°C . The SN74154 is characterized for operation from 0°C to 70°C .

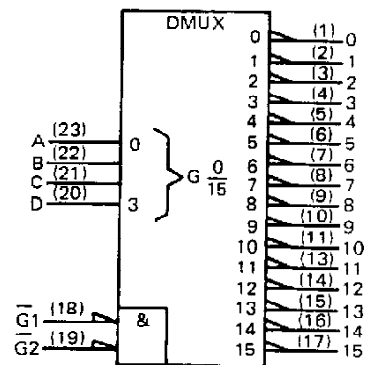
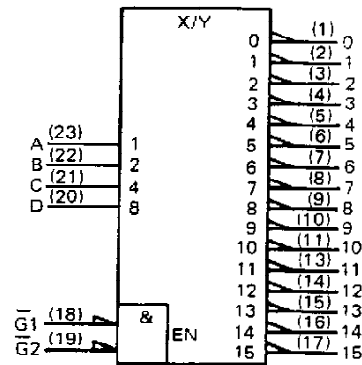

[†]These symbols are in accordance with ANSI/IEEE Std. 91-1984 and IEC Publication 617-12.

PRODUCTION DATA documents contain information current as of publication date. Products conform to specifications per the terms of Texas Instruments standard warranty. Production processing does not necessarily include testing of all parameters.



POST OFFICE BOX 655012 • DALLAS, TEXAS 75265

SN54154, SN74154
4-LINE TO 16-LINE DECODERS/DEMULTEPLEXERS

logic diagram (positive logic)

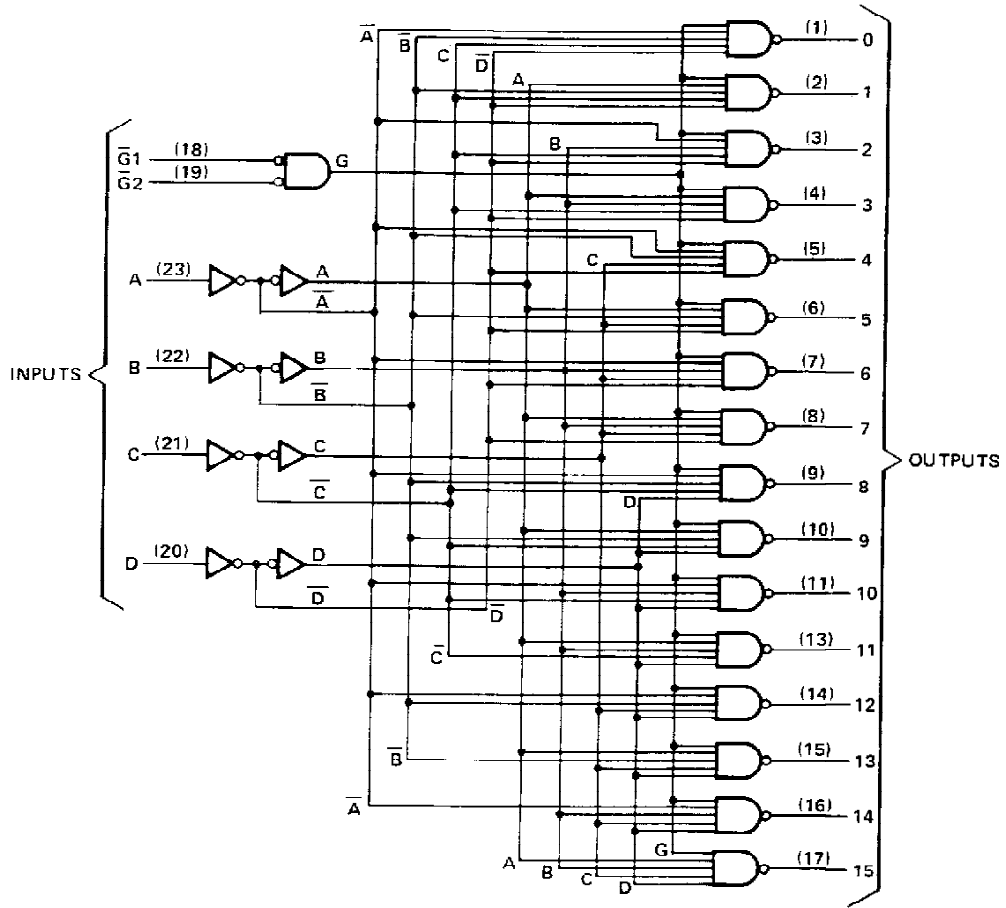

TEXAS
INSTRUMENTS

POST OFFICE BOX 6550 • DALLAS, TEXAS 75268

SN54154, SN74154

4-LINE TO 16-LINE DECODERS/DEMULTIPLEXERS

absolute maximum ratings over operating free-air temperature range (unless otherwise noted)

| | |
|--|----------------|
| Supply voltage, V_{CC} (see Note 1) | 7 V |
| Input voltage | 5.5 V |
| Operating free-air temperature range: SN54154 Circuits | -55°C to 125°C |
| SN74154 Circuits | 0°C to 70°C |
| Storage temperature range | -65°C to 150°C |

NOTE 1: Voltage values are with respect to network ground terminal.

recommended operating conditions

| | SN54154 | | | SN74154 | | | UNIT |
|---------------------------------------|---------|-----|------|---------|-----|------|---------|
| | MIN | NOM | MAX | MIN | NOM | MAX | |
| Supply voltage, V_{CC} | 4.5 | 5 | 5.5 | 4.75 | 5 | 5.25 | V |
| High-level output current, I_{OH} | | | -800 | | | -800 | μ A |
| Low-level output current, I_{OL} | | | 16 | | | 16 | mA |
| Operating free-air temperature, T_A | -55 | | 125 | 0 | | 70 | C |

electrical characteristics over recommended operating free-air temperature range (unless otherwise noted)

| PARAMETER | TEST CONDITIONS† | SN54154 | | | SN74154 | | | UNIT |
|--|--|---------|-----|------|---------|------|------|---------|
| | | MIN | TYP | MAX | MIN | TYP‡ | MAX | |
| V_{IH} High-level input voltage | | 2 | | | 2 | | | V |
| V_{IL} Low-level input voltage | | | | 0.8 | | | 0.8 | V |
| V_{IK} Input clamp voltage | $V_{CC} = \text{MIN}, I_I = -12 \text{ mA}$ | | | -1.5 | | | -1.5 | V |
| V_{OH} High-level output voltage | $V_{CC} = \text{MIN}, V_{IH} = 2 \text{ V}, V_{IL} = 0.8 \text{ V}, I_{OH} = -800 \mu\text{A}$ | 2.4 | 3.4 | | 2.4 | 3.4 | | V |
| V_{OL} Low-level output voltage | $V_{CC} = \text{MIN}, V_{IH} = 2 \text{ V}, V_{IL} = 0.8 \text{ V}, I_{OL} = 16 \text{ mA}$ | | 0.2 | 0.4 | | 0.2 | 0.4 | V |
| I_I Input current at maximum input voltage | $V_{CC} = \text{MAX}, V_I = 5.5 \text{ V}$ | | | 1 | | | 1 | mA |
| I_{IH} High-level input current | $V_{CC} = \text{MAX}, V_I = 2.4 \text{ V}$ | | | 40 | | | 40 | μ A |
| I_{IL} Low-level input current | $V_{CC} = \text{MAX}, V_I = 0.4 \text{ V}$ | | | -1.6 | | | -1.6 | mA |
| I_{OS} Short-circuit output current‡ | $V_{CC} = \text{MAX}$ | -20 | | -55 | -18 | | -57 | mA |
| I_{CC} Supply current | $V_{CC} = \text{MAX}$, See Note 2 | | 34 | 49 | | 34 | 56 | mA |

† For conditions shown as MIN or MAX, use the appropriate value specified under recommended operating conditions for the applicable type.

‡ All typical values are at $V_{CC} = 5 \text{ V}, T_A = 25^\circ \text{C}$.

§ Not more than one output should be shorted at a time.

NOTE 2: I_{CC} is measured with all inputs grounded and all outputs open.

switching characteristics, $V_{CC} = 5 \text{ V}, T_A = 25^\circ \text{C}$

| PARAMETER | TEST CONDITIONS | MIN | TYP | MAX | UNIT |
|---|--|-----|-----|-----|------|
| t_{PLH} Propagation delay time, low-to-high-level output, from A, B, C, or D inputs through 3 levels of logic | $C_L = 15 \text{ pF}, R_L = 400 \Omega,$ See Note 3 | | 24 | 36 | ns |
| t_{PHL} Propagation delay time, high-to-low-level output, from A, B, C, or D inputs through 3 levels of logic | | | 22 | 33 | ns |
| t_{PLH} Propagation delay time, low-to-high-level output, from either strobe input | | | 20 | 30 | ns |
| t_{PHL} Propagation delay time, high-to-low-level output, from either strobe input | | | 18 | 27 | ns |

NOTE 3: Load circuits and voltage waveforms are shown in Section 1.

TEXAS
INSTRUMENTS

POST OFFICE BOX 655012 • DALLAS, TEXAS 75265