



## 7N90

Power MOSFET

### 7A, 900V N-CHANNEL POWER MOSFET

#### DESCRIPTION

The UTC **7N90** is an N-channel mode power MOSFET using UTC's advanced technology to provide costumers with planar stripe and DMOS technology. This technology specializes in allowing a minimum on-state resistance and superior switching performance. It also can withstand high energy pulse in the avalanche and commutation mode.

The UTC **7N90** is universally applied in active power factor correction, electronic lamp ballast based on half bridge topology and high efficient switched mode power supply.

#### FEATURES

- \* High switching speed
- \*  $R_{DS(ON)} < 1.8\Omega$  @  $V_{GS}=10V$ ,  $I_D=3.5A$
- \* 100% avalanche tested
- \* Improved dv/dt capability

#### SYMBOL

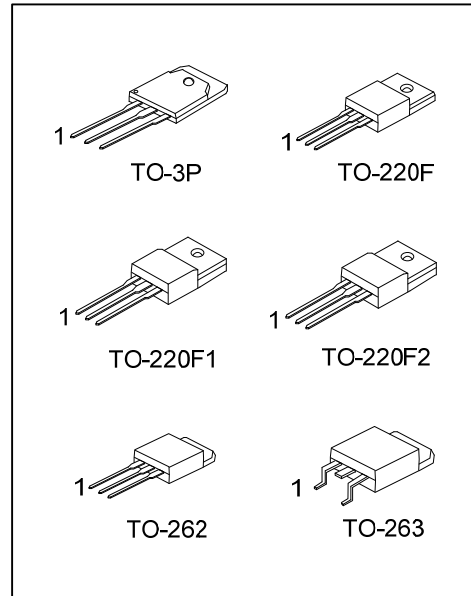
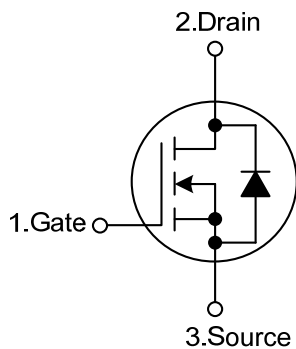

### ORDERING INFORMATION

Ordering Number		Package	Pin Assignment			Packing
Lead Free	Halogen Free		1	2	3	
7N90L-T3P-T	7N90G-T3P-T	TO-3P	G	D	S	Tube
7N90L-TF3-T	7N90G-TF3-T	TO-220F	G	D	S	Tube
7N90L-TF1-T	7N90G-TF1-T	TO-220F1	G	D	S	Tube
7N90L-TF2-T	7N90G-TF2-T	TO-220F2	G	D	S	Tube
7N90L-T2Q-T	7N90G-T2Q-T	TO-262	G	D	S	Tube
7N90L-TQ2-T	7N90G-TQ2-T	TO-263	G	D	S	Tube
7N90L-TQ2-R	7N90G-TQ2-R	TO-263	G	D	S	Tape Reel

Note: Pin Assignment: G: Gate D: Drain S: Source

<p>7N90L-T3P-T</p> <p>(1) Packing Type (2) Package Type (3) Green Package</p>	<p>(1) T: Tube (2) T3P: TO-3P, TF1: TO-220F1, TF2: TO-220F2 TF3: TO-220F, T2Q: TO-262 (3) L: Lead Free, G: Halogen Free and Lead Free</p>
---	---

### MARKING

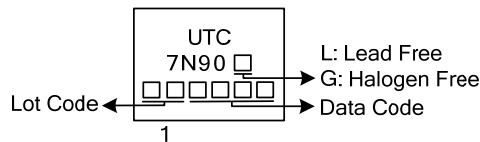

### ■ ABSOLUTE MAXIMUM RATINGS

PARAMETER		SYMBOL	RATINGS	UNIT
Drain to Source Voltage		$V_{DSS}$	900	V
Gate to Source Voltage		$V_{GSS}$	$\pm 30$	V
Continuous Drain Current	$T_C=25^\circ\text{C}$	$I_D$	7.0	A
	$T_C=100^\circ\text{C}$		4.4	A
Pulsed Drain Current (Note 2)		$I_{DM}$	28	A
Avalanche Current (Note 2)		$I_{AR}$	6.4	A
Single Pulsed Avalanche Energy (Note 3)		$E_{AS}$	500	mJ
Repetitive Avalanche Energy (Note 2)		$E_{AR}$	21	mJ
Peak Diode Recovery dv/dt (Note 4)		dv/dt	4.0	V/ns
Power Dissipation	TO-3P	$P_D$	240	W
	TO-220F/TO-220F1		52	
	TO-220F2			
	TO-262/TO-263		180	
Junction Temperature		$T_J$	+150	$^\circ\text{C}$
Storage Temperature		$T_{STG}$	-55 ~ +150	$^\circ\text{C}$

Notes: 1. Absolute maximum ratings are those values beyond which the device could be permanently damaged.

Absolute maximum ratings are stress ratings only and functional device operation is not implied.

2. Repetitive Rating : Pulse width limited by maximum junction temperature

3.  $L=20\text{mH}$ ,  $I_{AS}=7.0\text{A}$ ,  $V_{DD}=50\text{V}$ ,  $R_G=25\Omega$ , Starting  $T_J=25^\circ\text{C}$

4.  $I_{SD}\leq 7.0\text{A}$ ,  $di/dt\leq 200\text{A}/\mu\text{s}$ ,  $V_{DD}\leq BV_{DSS}$ , Starting  $T_J=25^\circ\text{C}$

### ■ THERMAL DATA

PARAMETER		SYMBOL	RATINGS	UNIT
Junction to Ambient	TO-3P	$\theta_{JA}$	40	$^\circ\text{C}/\text{W}$
	TO-220F/TO-220F1		62.5	
	TO-220F2/TO-262			
	TO-263			
Junction to Case	TO-3P	$\theta_{JC}$	0.52	$^\circ\text{C}/\text{W}$
	TO-220F/TO-220F1		2.4	
	TO-220F2			
	TO-262/TO-263		0.69	

■ ELECTRICAL CHARACTERISTICS (T<sub>c</sub>=25°C, unless otherwise specified)

PARAMETER	SYMBOL	TEST CONDITIONS	MIN	TYP	MAX	UNIT
<b>OFF CHARACTERISTICS</b>						
Drain-Source Breakdown Voltage	BV <sub>DSS</sub>	V <sub>GS</sub> =0V, I <sub>D</sub> =250μA	900			V
Breakdown Voltage Temperature Coefficient	ΔBV <sub>DSS</sub> /ΔT <sub>J</sub>	I <sub>D</sub> =250μA, Referenced to 25°C		0.96		V/°C
Drain-Source Leakage Current	I <sub>DSS</sub>	V <sub>DS</sub> =900V, V <sub>GS</sub> =0V			10	μA
		V <sub>DS</sub> =720V, T <sub>c</sub> =125°C			100	μA
Gate-Source Leakage Current	Forward	I <sub>GSS</sub> V <sub>DS</sub> =0V, V <sub>GS</sub> =30V			100	nA
	Reverse	I <sub>GSS</sub> V <sub>DS</sub> =0V, V <sub>GS</sub> =-30V			-100	nA
<b>ON CHARACTERISTICS</b>						
Gate Threshold Voltage	V <sub>GS(TH)</sub>	V <sub>DS</sub> =V <sub>GS</sub> , I <sub>D</sub> =250μA	3.0		5.0	V
Drain-Source On-State Resistance	R <sub>DS(ON)</sub>	V <sub>GS</sub> =10V, I <sub>D</sub> =3.5A		1.5	1.8	Ω
Forward Transconductance	g <sub>FS</sub>	V <sub>DS</sub> =50V, I <sub>D</sub> =3.5A (Note 4)		5.7		S
<b>DYNAMIC PARAMETERS</b>						
Input Capacitance	C <sub>ISS</sub>	V <sub>DS</sub> =25V, V <sub>GS</sub> =0V, f=1.0MHz		1440	1880	pF
Output Capacitance	C <sub>OSS</sub>			140	185	pF
Reverse Transfer Capacitance	C <sub>RSS</sub>			17	23	pF
<b>SWITCHING PARAMETERS</b>						
Turn-ON Delay Time	t <sub>D(ON)</sub>	V <sub>DD</sub> =30V, I <sub>D</sub> =1A, R <sub>G</sub> =25Ω (Note 4,5)		90		ns
Turn-ON Rise Time	t <sub>R</sub>			100		ns
Turn-OFF Delay Time	t <sub>D(OFF)</sub>			260		ns
Turn-OFF Fall Time	t <sub>F</sub>			140		ns
Total Gate Charge	Q <sub>G</sub>	V <sub>DS</sub> =120V, V <sub>GS</sub> =10V, I <sub>D</sub> =11A (Note 4,5)		160		nC
Gate-Source Charge	Q <sub>GS</sub>			15		nC
Gate-Drain Charge	Q <sub>GD</sub>			35		nC
<b>SOURCE- DRAIN DIODE RATINGS AND CHARACTERISTICS</b>						
Maximum Body-Diode Continuous Current	I <sub>S</sub>				6.4	A
Maximum Body-Diode Pulsed Current	I <sub>SM</sub>				25.6	A
Drain-Source Diode Forward Voltage	V <sub>SD</sub>	I <sub>S</sub> =7.0A, V <sub>GS</sub> =0V			1.4	V
Body Diode Reverse Recovery Time	t <sub>rr</sub>	V <sub>GS</sub> =0V, I <sub>S</sub> =7.0A,		400		ns
Body Diode Reverse Recovery Charge	Q <sub>RR</sub>	dI <sub>F</sub> /dt=100A/μs (Note 4)		4.3		μC

Notes: 1. Pulse Test : Pulse width ≤ 300μs, Duty cycle ≤ 2%

2. Essentially independent of operating temperature

■ TEST CIRCUITS AND WAVEFORMS

Peak Diode Recovery dv/dt Test Circuit & Waveforms

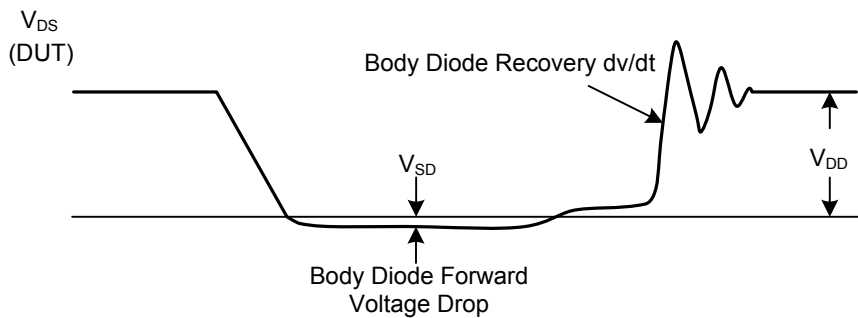
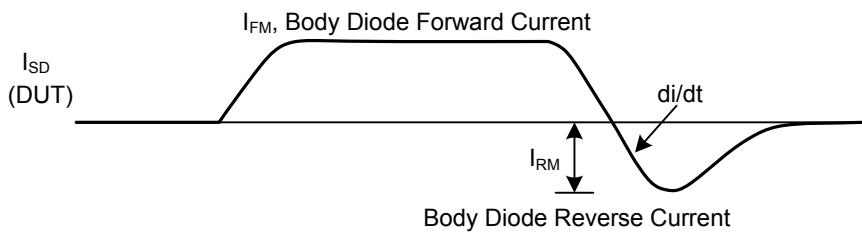
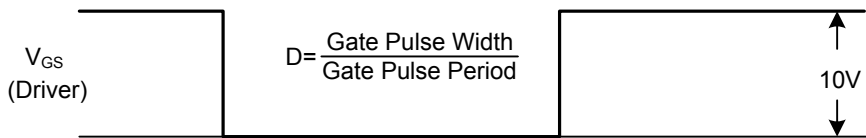
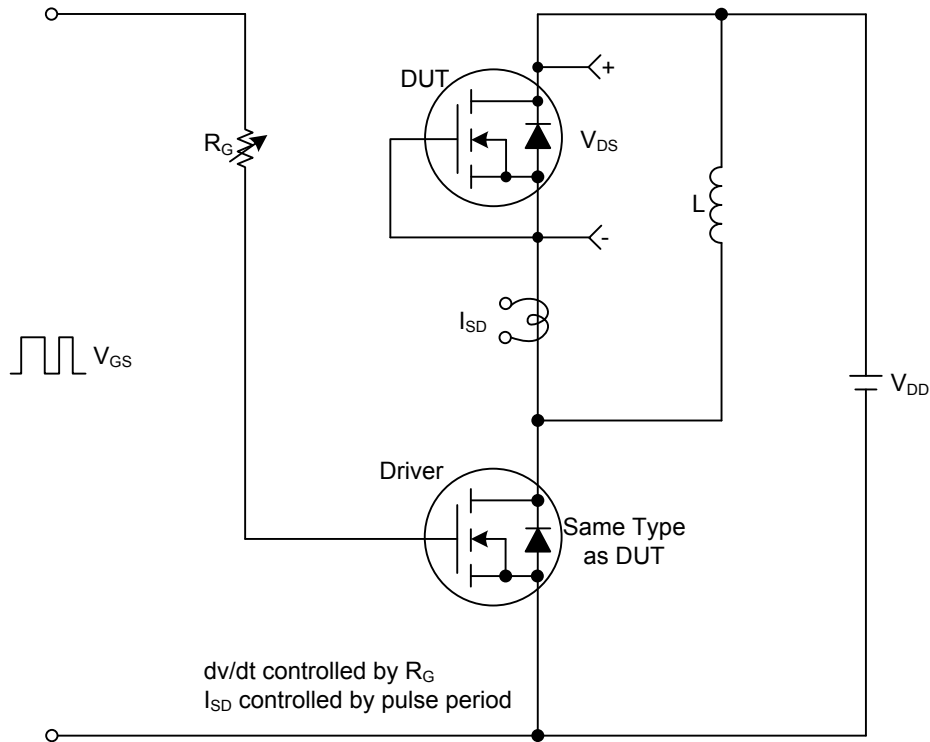

■ TEST CIRCUITS AND WAVEFORMS(Cont.)

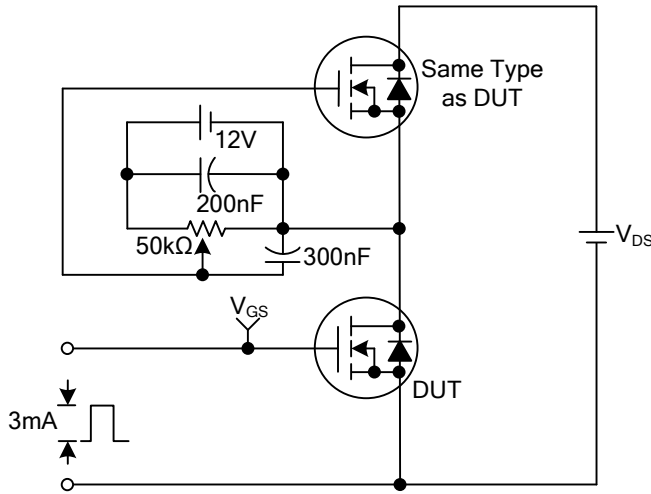

Gate Charge Test Circuit

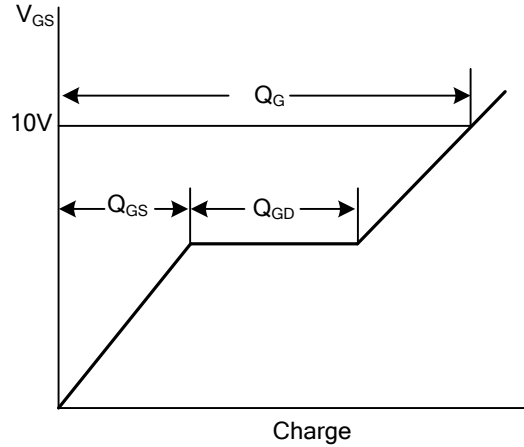

Gate Charge Waveforms

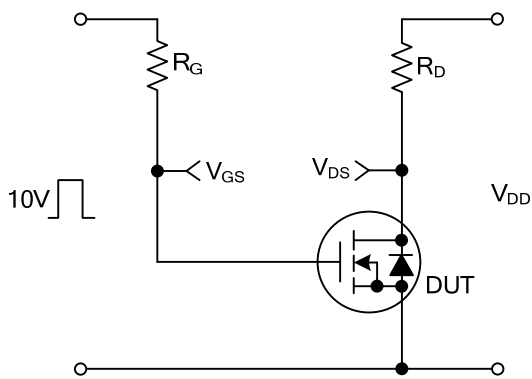

Resistive Switching Test Circuit

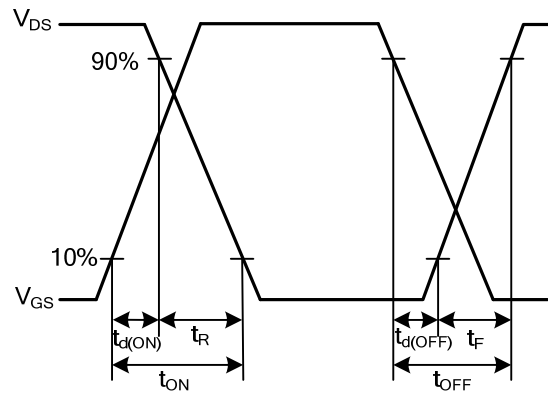

Resistive Switching Waveforms

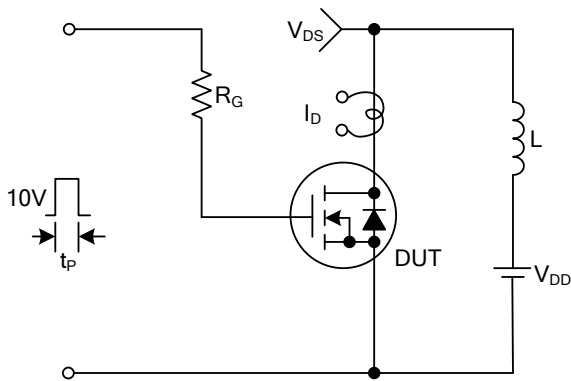

Unclamped Inductive Switching Test Circuit

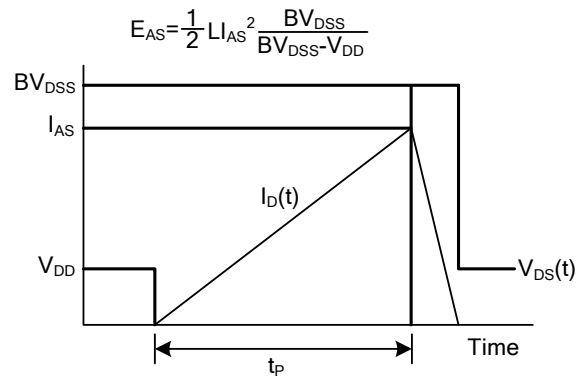

Unclamped Inductive Switching Waveforms

UTC assumes no responsibility for equipment failures that result from using products at values that exceed, even momentarily, rated values (such as maximum ratings, operating condition ranges, or other parameters) listed in products specifications of any and all UTC products described or contained herein. UTC products are not designed for use in life support appliances, devices or systems where malfunction of these products can be reasonably expected to result in personal injury. Reproduction in whole or in part is prohibited without the prior written consent of the copyright owner. The information presented in this document does not form part of any quotation or contract, is believed to be accurate and reliable and may be changed without notice.