

256K x 16Bit CMOS Dynamic RAM with Fast Page Mode

DESCRIPTION

This is a family of 262,144 x 16 bit Fast Page Mode CMOS DRAMs. Fast Page Mode offers high speed random access of memory cells within the same row. Power supply voltage (+5.0V or +3.3V), access time (-5,-6,-7), power consumption(Normal or Low power) and package type(SOJ or TSOP-II) are optional features of this family. All of this family have $\overline{\text{CAS}}$ -before- $\overline{\text{RAS}}$ refresh, $\overline{\text{RAS}}$ -only refresh and Hidden refresh capabilities. Furthermore, Self-refresh operation is available in L-version. This 256Kx16 fast page mode DRAM family is fabricated using Samsung's advanced CMOS process to realize high band-width, low power consumption and high reliability. It may be used as graphic memory unit for microcomputer, personal computer and portable machines.

FEATURES

• Part Identification

- KM416C256D/DL (5V, 512 Ref.)
- KM416V256D/DL (3.3V, 512 Ref.)

• Active Power Dissipation

Unit : mW

Speed	3.3V(512 Ref.)	5V(512 Ref.)
-5	-	605
-6	325	495
-7	290	440

• Refresh Cycles

Part NO.	V _{CC}	Refresh cycle	Refresh period	
			Normal	L-ver
C256D	5V	512	8ms	128ms
V256D	3.3V			

• Performance Range

Speed	t _{RAC}	t _{CAC}	t _{RC}	t _{PC}	Remark
-5	50ns	15ns	90ns	35ns	5V only
-6	60ns	15ns	10ns	40ns	5V/3.3V
-7	70ns	20ns	130ns	45ns	5V/3.3V

- Fast Page Mode operation
- 2 $\overline{\text{CAS}}$ Byte/Wrod Read/Write operation
- $\overline{\text{CAS}}$ -before- $\overline{\text{RAS}}$ refresh capability
- $\overline{\text{RAS}}$ -only and Hidden refresh capability
- Self-refresh capability (L-ver only)
- TTL(5V)/LVTTTL(3.3V) compatible inputs and outputs
- Early Write or output enable controlled write
- JEDEC Standard pinout
- Available in 40-pin SOJ 400mil and 44(40)-pin TSOP(II) 400mil packages
- Triple +5V±10% power supply(5V product)
- Triple +3.3V±0.3V power supply(3.3V product)

FUNCTIONAL BLOCK DIAGRAM

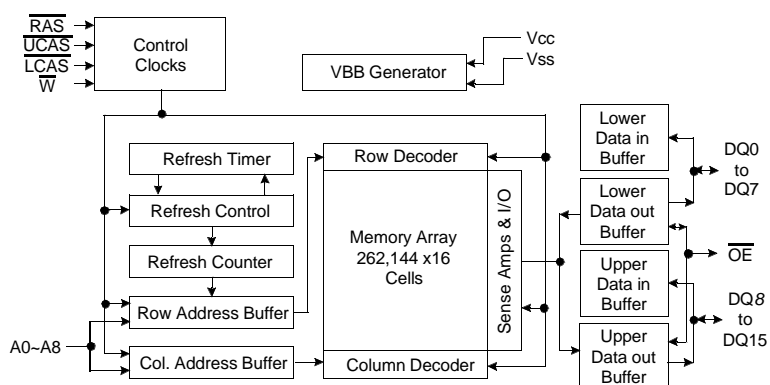

SAMSUNG ELECTRONICS CO., LTD. reserves the right to change products and specifications without notice.



PIN CONFIGURATION (Top Views)

•KM416C/V254DJ

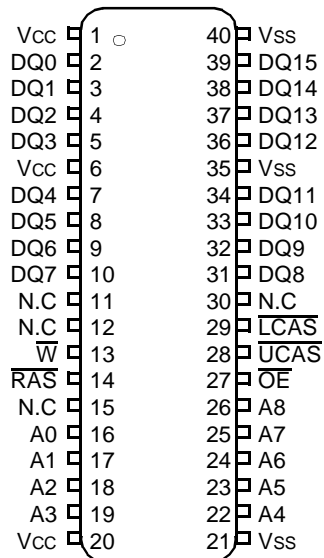

(SOJ)

•KM416C/V254DT

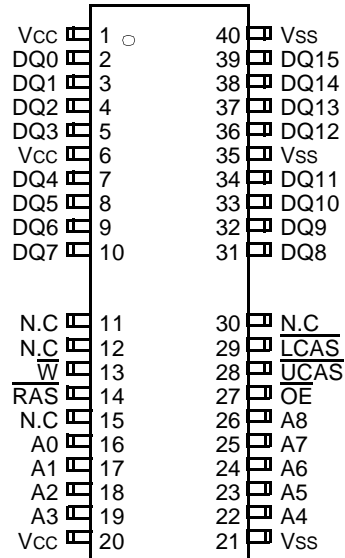

(TSOP-II)

Pin Name	Pin Function
A0 - A8	Address Inputs
DQ0 - 15	Data In/Out
Vss	Ground
$\overline{\text{RAS}}$	Row Address Strobe
$\overline{\text{UCAS}}$	Upper Column Address Strobe
$\overline{\text{LCAS}}$	Lower Column Address Strobe
$\overline{\text{W}}$	Read/Write Input
$\overline{\text{OE}}$	Data Output Enable
Vcc	Power(+5V)
	Power(+3.3V)
N.C	No Connection

ABSOLUTE MAXIMUM RATINGS

Parameter	Symbol	Rating		Units
		3.3V	5V	
Voltage on any pin relative to Vss	V _{IN} , V _{OUT}	-0.5 to +4.6	-1.0 to +7.0	V
Voltage on Vcc supply relative to Vss	V _{CC}	-0.5 to +4.6	-1.0 to +7.0	V
Storage Temperature	T _{stg}	-55 to +150	-55 to +150	°C
Power Dissipation	P _D	1	1	W
Short Circuit Output Current	I _{os}	50	50	mA

* Permanent device damage may occur if "ABSOLUTE MAXIMUM RATINGS" are exceeded. Functional operation should be restricted to the conditions as detailed in the operational sections of this data sheet. Exposure to absolute maximum rating conditions for extended periods may affect device reliability.

RECOMMENDED OPERATING CONDITIONS (Voltage referenced to Vss, T_A= 0 to 70°C)

Parameter	Symbol	3.3V			5V			Units
		Min	Typ	Max	Min	Typ	Max	
Supply Voltage	V _{CC}	3.0	3.3	3.6	4.5	5.0	5.5	V
Ground	V _{SS}	0	0	0	0	0	0	V
Input High Voltage	V _{IH}	2.0	-	V _{CC} +0.3* ¹	2.4	-	V _{CC} +1.0* ¹	V
Input Low Voltage	V _{IL}	-0.3* ²	-	0.8	-1.0* ²	-	0.8	V

*1 : V_{CC}+1.3V/15ns(3.3V), V_{CC}+2.0V/20ns(5V), Pulse width is measured at V_{CC}

*2 : -1.3V/15ns(3.3V), -2.0V/20ns(5V), Pulse width is measured at V_{SS}

DC AND OPERATING CHARACTERISTICS (Recommended operating conditions unless otherwise noted.)

Max	Parameter	Symbol	Min	Max	Units
3.3V	Input Leakage Current (Any input 0≤V _{IN} ≤V _{IN} +0.3V, all other input pins not under test=0 Volt)	I _{I(L)}	-5	5	uA
	Output Leakage Current (Data out is disabled, 0V≤V _{OUT} ≤V _{CC})	I _{O(L)}	-5	5	uA
	Output High Voltage Level(I _{OH} =-2mA)	V _{OH}	2.4	-	V
	Output Low Voltage Level(I _{OL} =2mA)	V _{OL}	-	0.4	V
5V	Input Leakage Current (Any input 0≤V _{IN} ≤V _{IN} +0.5V, all other input pins not under test=0 Volt)	I _{I(L)}	-5	5	uA
	Output Leakage Current (Data out is disabled, 0V≤V _{OUT} ≤V _{CC})	I _{O(L)}	-5	5	uA
	Output High Voltage Level(I _{OH} =-5mA)	V _{OH}	2.4	-	V
	Output Low Voltage Level(I _{OL} =4.2mA)	V _{OL}	-	0.4	V



DC AND OPERATING CHARACTERISTICS (Continued)

Symbol	Power	Speed	Max		Units
			KM416V254D	KM416C254D	
I _{CC1}	Don't care	-5	-	110	mA
		-6	90	90	
		-7	80	80	
I _{CC2}	Don't care	Don't care	1	2	mA
I _{CC3}	Don't care	-5	-	110	mA
		-6	90	90	
		-7	80	80	
I _{CC4}	Don't care	-5	-	70	mA
		-6	60	60	
		-7	55	55	
I _{CC5}	Normal L	Don't care	0.5	1	mA
			100	150	
I _{CC6}	Don't care	-5	-	110	mA
		-6	90	90	
		-7	80	80	
I _{CC7}	L	Don't care	200	300	uA
I _{CCS}	L	Don't care	100	200	uA

I_{CC1}* : Operating Current (\overline{RAS} and \overline{UCAS} , \overline{LCAS} , Address cycling @trc=min.)

I_{CC2} : Standby Current ($\overline{RAS}=\overline{UCAS}=\overline{LCAS}=\overline{W}=V_{IH}$)

I_{CC3}* : \overline{RAS} -only Refresh Current ($\overline{UCAS}=\overline{LCAS}=V_{IH}$, \overline{RAS} , Address cycling @trc=min.)

I_{CC4}* : Fast Page Mode Current ($\overline{RAS}=V_{IL}$, \overline{UCAS} or \overline{LCAS} , Address cycling @tpc=min.)

I_{CC5} : Standby Current ($\overline{RAS}=\overline{UCAS}=\overline{LCAS}=\overline{W}=V_{CC}-0.2V$)

I_{CC6}* : \overline{CAS} -Before- \overline{RAS} Refresh Current (\overline{RAS} and \overline{UCAS} or \overline{LCAS} cycling @trc=min.)

I_{CC7} : Battery back-up current, Average power supply current, Battery back-up mode
 Input high voltage(V_{IH})= $V_{CC}-0.2V$, Input low voltage(V_{IL})= $0.2V$, \overline{UCAS} , $\overline{LCAS}=0.2V$,
 DQ=Don't care, TRC=125us, TRAS=TRASmin~300ns

I_{CCS} : Self Refresh Current

$\overline{RAS}=\overline{UCAS}=\overline{LCAS}=V_{IL}$, $\overline{W}=\overline{OE}=A0 \sim A8=V_{CC}-0.2V$ or $0.2V$,

DQ0 ~ DQ15= $V_{CC}-0.2V$, $0.2V$ or Open

*Note : I_{CC1}, I_{CC3}, I_{CC4} and I_{CC6} are dependent on output loading and cycle rates. Specified values are obtained with the output open. I_{CC} is specified as an average current. In I_{CC1}, I_{CC3}, I_{CC6} and I_{CC7}, address can be changed maximum once while $\overline{RAS}=V_{IL}$. In I_{CC4}, address can be changed maximum once within one fast page mode cycle time, tpc.

CAPACITANCE ($T_A=25^\circ\text{C}$, $V_{CC}=5\text{V}$ or 3.3V , $f=1\text{MHz}$)

Parameter	Symbol	Min	Max	Units
Input capacitance [A0 ~ A8]	CIN1	-	5	pF
Input capacitance [$\overline{\text{RAS}}$, $\overline{\text{UCAS}}$, $\overline{\text{LCAS}}$, $\overline{\text{W}}$, $\overline{\text{OE}}$]	CIN2	-	7	pF
Output capacitance [DQ0 - DQ15]	CDQ	-	7	pF

AC CHARACTERISTICS ($0^\circ\text{C} \leq T_A \leq 70^\circ\text{C}$, See note 1,2)

 Test condition (5V device) : $V_{CC}=5.0\text{V} \pm 10\%$, $V_{ih}/V_{il}=2.4/0.8\text{V}$, $V_{oh}/V_{ol}=2.4/0.4\text{V}$

 Test condition (3.3V device): $V_{CC}=3.3\text{V} \pm 0.3\text{V}$, $V_{ih}/V_{il}=2.2/0.7\text{V}$, $V_{oh}/V_{ol}=2.0/0.8\text{V}$

Parameter	Symbol	-5*1		-6		-7		Units	Notes
		Min	Max	Min	Max	Min	Max		
Random read or write cycle time	t _{RC}	90		110		130		ns	
Read-modify-write cycle time	t _{RWC}	132		152		177		ns	
Access time from $\overline{\text{RAS}}$	t _{RAC}		50		60		70	ns	3,4,10
Access time from $\overline{\text{CAS}}$	t _{CAC}		15		15		20	ns	3,4,5
Access time from column address	t _{AA}		25		30		35	ns	3,10
$\overline{\text{CAS}}$ to output in Low-Z	t _{CLZ}	0		0		0		ns	3
Output buffer turn-off delay	t _{OFF}	0	12	0	12	0	17	ns	6
Transition time (rise and fall)	t _T	3	50	3	50	3	50	ns	2
$\overline{\text{RAS}}$ precharge time	t _{RP}	30		40		50		ns	
$\overline{\text{RAS}}$ pulse width	t _{RAS}	50	10K	60	10K	70	10K	ns	
$\overline{\text{RAS}}$ hold time	t _{RSH}	15		15		20		ns	
$\overline{\text{CAS}}$ hold time	t _{CSH}	50		60		70		ns	
$\overline{\text{CAS}}$ pulse width	t _{CAS}	15	10K	15	10K	20	10K	ns	
$\overline{\text{RAS}}$ to $\overline{\text{CAS}}$ delay time	t _{RCD}	20	35	20	45	20	50	ns	4
$\overline{\text{RAS}}$ to column address delay time	t _{RAD}	15	25	15	30	15	35	ns	10
$\overline{\text{CAS}}$ to $\overline{\text{RAS}}$ precharge time	t _{CRP}	5		5		5		ns	
Row address set-up time	t _{ASR}	0		0		0		ns	
Row address hold time	t _{RAH}	10		10		10		ns	
Column address set-up time	t _{ASC}	0		0		0		ns	11
Column address hold time	t _{CAH}	10		10		15		ns	11
Column address to $\overline{\text{RAS}}$ lead time	t _{RAL}	25		30		35		ns	
Read command set-up time	t _{RCS}	0		0		0		ns	
Read command hold time referenced to $\overline{\text{CAS}}$	t _{RCH}	0		0		0		ns	8
Read command hold time referenced to $\overline{\text{RAS}}$	t _{RRH}	0		0		0		ns	8
Write command set-up time	t _{WCS}	0		0		0		ns	7
Write command hold time	t _{WCH}	10		10		15		ns	
Write command pulse width	t _{WP}	10		10		15		ns	
Write command to $\overline{\text{RAS}}$ lead time	t _{RWL}	15		15		15		ns	
Write command to $\overline{\text{CAS}}$ lead time	t _{CWL}	13		15		15		ns	14

Note) *1 : 5V only



AC CHARACTERISTICS (Continued)

Parameter	Symbol	-5*1		-6		-7		Units	Notes
		Min	Max	Min	Max	Min	Max		
Data set-up time	tDS	0		0		0		ns	9,17
Data hold time	tDH	10		10		15		ns	9,17
Refresh period (Normal)	tREF		8		8		8	ms	
Refresh period (L-ver)	tREF		128		128		128	ms	
$\overline{\text{CAS}}$ to $\overline{\text{W}}$ delay time	tCWD	37		37		47		ns	7,13
$\overline{\text{RAS}}$ to $\overline{\text{W}}$ delay time	tRWD	72		82		97		ns	7
Column address to $\overline{\text{W}}$ delay time	tAWD	47		52		62		ns	7
$\overline{\text{CAS}}$ precharge to $\overline{\text{W}}$ delay time	tCPWD	52		57		67		ns	7
$\overline{\text{CAS}}$ set-up time ($\overline{\text{CAS}}$ -before- $\overline{\text{RAS}}$ refresh)	tCSR	10		10		10		ns	15
$\overline{\text{CAS}}$ hold time ($\overline{\text{CAS}}$ -before- $\overline{\text{RAS}}$ refresh)	tCHR	10		10		10		ns	16
$\overline{\text{RAS}}$ to $\overline{\text{CAS}}$ precharge time	tRPC	5		5		5		ns	
$\overline{\text{CAS}}$ precharge time ($\overline{\text{C}}$ - $\overline{\text{B}}$ - $\overline{\text{R}}$ counter test cycle)	tCPT	20		20		25		ns	
Access time from $\overline{\text{CAS}}$ precharge	tCPA		30		35		40	ns	3
Fast Page mode cycle time	tPC	35		40		45		ns	
Fast Page read-modify-write cycle time	tPRWC	77		82		97		ns	
$\overline{\text{CAS}}$ precharge time (Fast Page cycle)	tCP	10		10		10		ns	12
$\overline{\text{RAS}}$ pulse width (Fast Page cycle)	tRASP	50	100K	60	100K	70	100K	ns	
$\overline{\text{RAS}}$ hold time from $\overline{\text{CAS}}$ precharge	tRHCP	30		35		40		ns	
$\overline{\text{OE}}$ access time	tOEA		15		15		20	ns	
$\overline{\text{OE}}$ to data delay	tOED	12		12		17		ns	
Output buffer turn off delay time from $\overline{\text{OE}}$	tOEZ	0	12	0	12	0	17	ns	6
$\overline{\text{OE}}$ command hold time	tOEH	15		15		20		ns	
$\overline{\text{RAS}}$ pulse width ($\overline{\text{C}}$ - $\overline{\text{B}}$ - $\overline{\text{R}}$ self refresh)	tRASS	100		100		100		us	18,19,20
$\overline{\text{RAS}}$ precharge time ($\overline{\text{C}}$ - $\overline{\text{B}}$ - $\overline{\text{R}}$ self refresh)	tRPS	90		110		130		ns	18,19,20
$\overline{\text{CAS}}$ hold time ($\overline{\text{C}}$ - $\overline{\text{B}}$ - $\overline{\text{R}}$ self refresh)	tCHS	-50		-50		-50		ns	18,19,20

Note) *1 : 5V only

NOTES

1. An initial pause of 200us is required after power-up followed by any 8 $\overline{\text{RAS}}$ -only refresh or $\overline{\text{CAS}}$ -before- $\overline{\text{RAS}}$ refresh cycles before proper device operation is achieved.
2. $V_{IH}(\text{min})$ and $V_{IL}(\text{max})$ are reference levels for measuring timing of input signals.
Transition times are measured between $V_{IH}(\text{min})$ and $V_{IL}(\text{max})$ and are assumed to be 5ns for all inputs.
3. Measured with a load equivalent to 2 TTL(5V)/1 TTL(3.3V) loads and 50pF.
4. Operation within the $t_{\text{RCD}}(\text{max})$ limit insures that $t_{\text{RAC}}(\text{max})$ can be met. $t_{\text{RCD}}(\text{max})$ is specified as a reference point only.
If t_{RCD} is greater than the specified $t_{\text{RCD}}(\text{max})$ limit, then access time is controlled exclusively by t_{CAC} .
5. Assumes that $t_{\text{RCD}} \geq t_{\text{RCD}}(\text{max})$.
6. This parameter defines the time at which the output achieves the open circuit condition and is not referenced to V_{oh} or V_{ol} .
7. t_{WCS} , t_{RWD} , t_{CWD} , t_{AWD} and t_{CPWD} are non restrictive operating parameters. They are included in the data sheet as electrical characteristics only. If $t_{\text{WCS}} \geq t_{\text{WCS}}(\text{min})$, the cycle is an early write cycle and the data output will remain high impedance for the duration of the cycle. If $t_{\text{CWD}} \geq t_{\text{CWD}}(\text{min})$, $t_{\text{RWD}} \geq t_{\text{RWD}}(\text{min})$, $t_{\text{AWD}} \geq t_{\text{AWD}}(\text{min})$ and $t_{\text{CPWD}} \geq t_{\text{CPWD}}(\text{min})$ then the cycle is a read-modify-write cycle and the data output will contain the data read from the selected address. If neither of the above conditions is satisfied, the condition of the data out is indeterminate.
8. Either t_{RCH} or t_{RRH} must be satisfied for a read cycle.
9. These parameters are referenced to the first $\overline{\text{CAS}}$ falling edge in early write cycles and to $\overline{\text{W}}$ falling edge in $\overline{\text{OE}}$ controlled write cycle and read-modify-write cycles.
10. Operation within the $t_{\text{RAD}}(\text{max})$ limit insures that $t_{\text{RAC}}(\text{max})$ can be met. $t_{\text{RAD}}(\text{max})$ is specified as a reference point only.
If t_{RAD} is greater than the specified $t_{\text{RAD}}(\text{max})$ limit, then access time is controlled by t_{AA} .
11. t_{ASC} , t_{CAH} are referenced to the earlier $\overline{\text{CAS}}$ rising edge.
12. t_{CP} is specified from the last $\overline{\text{CAS}}$ rising edge in the previous cycle to the first $\overline{\text{CAS}}$ falling edge in the next cycle.

KM416C/V256D/DL Truth Table

$\overline{\text{RAS}}$	$\overline{\text{LCAS}}$	$\overline{\text{UCAS}}$	$\overline{\text{W}}$	$\overline{\text{OE}}$	DQ0 - DQ7	DQ8-DQ15	STATE
H	H	H	H	H	Hi-Z	Hi-Z	Standby
L	H	H	H	H	Hi-Z	Hi-Z	Refresh
L	L	H	H	L	DQ-OUT	Hi-Z	Byte Read
L	H	L	H	L	Hi-Z	DQ-OUT	Byte Read
L	L	L	H	L	DQ-OUT	DQ-OUT	Word Read
L	L	H	L	H	DQ-IN	-	Byte Write
L	H	L	L	H	-	DQ-IN	Byte Write
L	L	L	L	H	DQ-IN	DQ-IN	Word Write
L	L	L	H	H	Hi-Z	Hi-Z	-

- 13. t_{CWD} is referenced to the later \overline{CAS} falling edge at word read-modify-write cycle.
- 14. t_{CWL} is specified from \overline{W} falling edge to the earlier \overline{CAS} rising edge.
- 15. t_{CSR} is referenced to earlier \overline{CAS} falling low before \overline{RAS} transition low.
- 16. t_{CHR} is referenced to the later \overline{CAS} rising high after \overline{RAS} transition low.

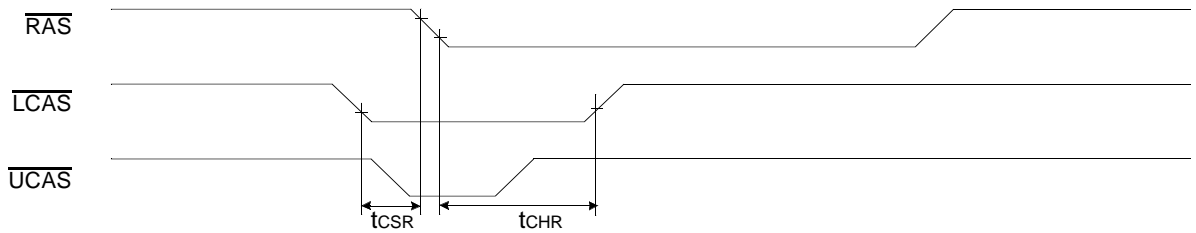

- 17. t_{DS} , t_{DH} are specified for earlier \overline{CAS} falling low.

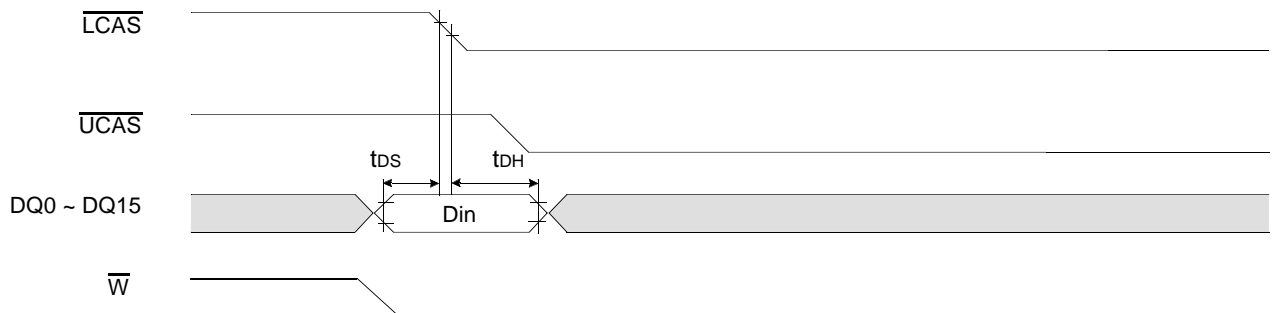

- 18. If $t_{RAS} \geq 100\mu s$, then \overline{RAS} precharge time must use t_{RPS} instead of t_{RP} .
- 19. For \overline{RAS} -only refresh and burst \overline{CAS} -before- \overline{RAS} refresh mode, 512(512K) cycle of burst refresh must be executed within 8ms before and after self refresh, in order to meet refresh specification.
- 20. For distributed \overline{CAS} -before- \overline{RAS} with 15.6 μs interval, \overline{CAS} -before- \overline{RAS} refresh should be executed with in 15.6 μs immediately before and after self refresh in order to meet refresh specification.

WORD READ CYCLE

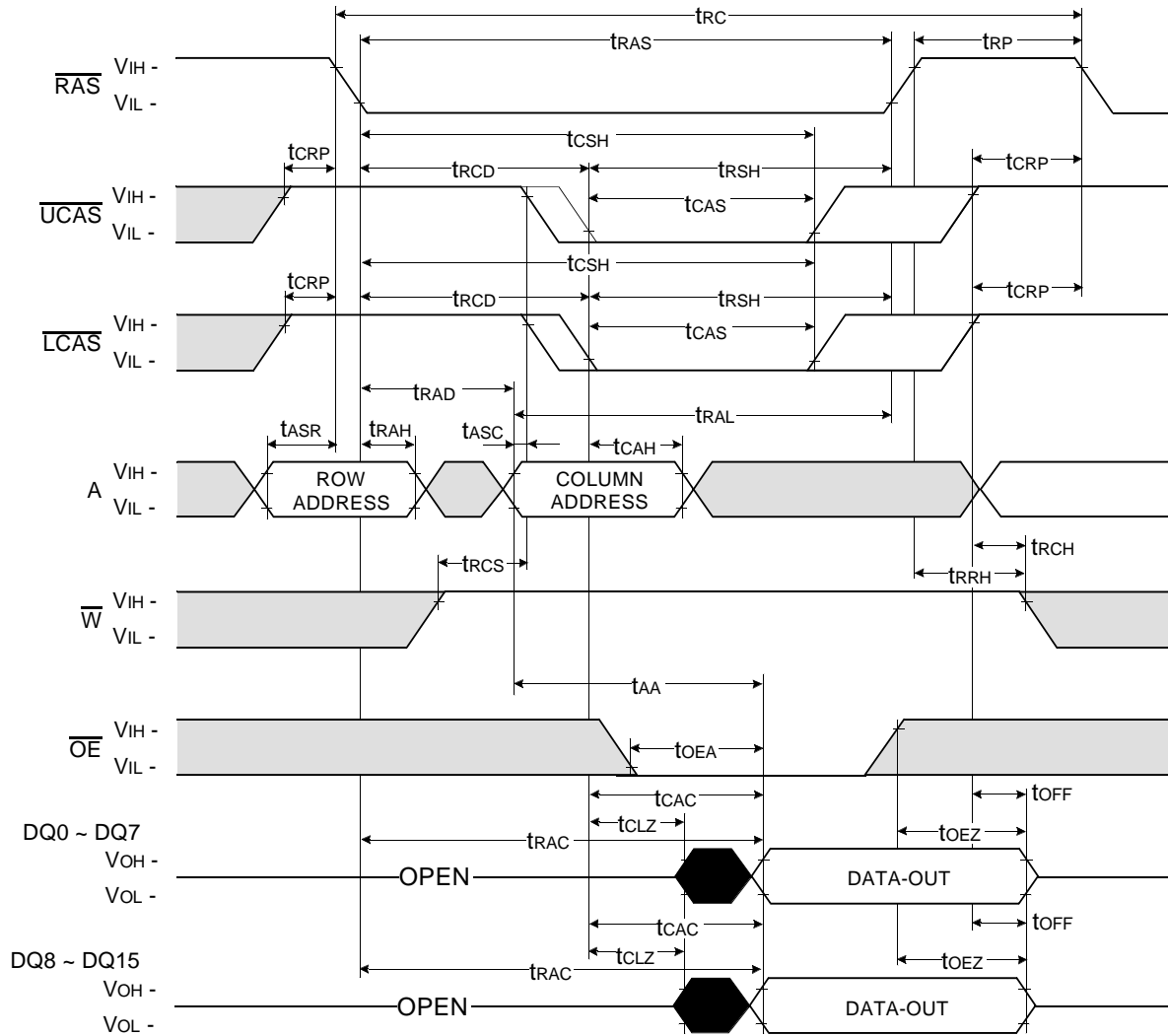

LOWER BYTE READ CYCLE

NOTE : DIN = OPEN

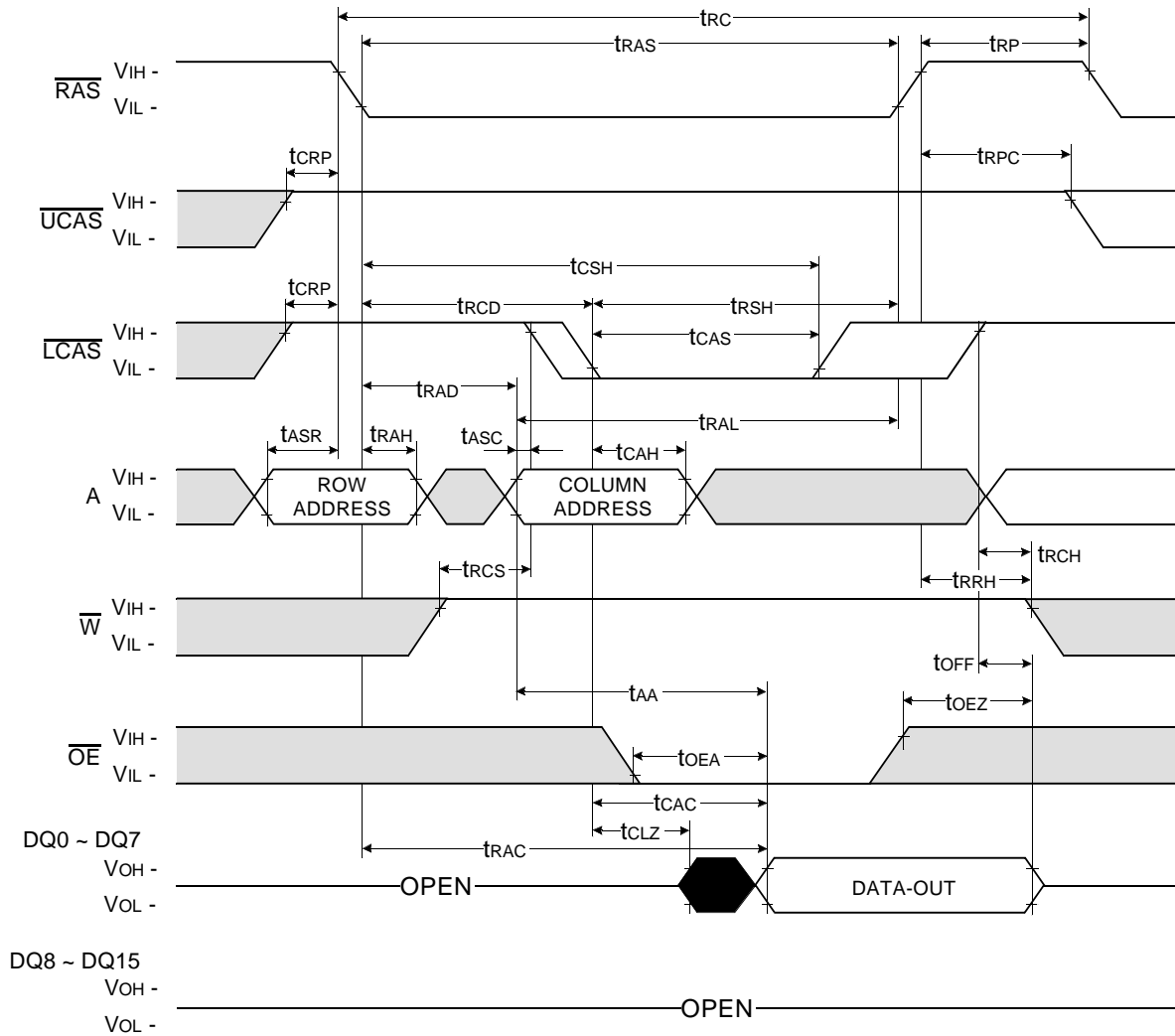

Don't care
 Undefined

UPPER BYTE READ CYCLE

NOTE : DIN = OPEN

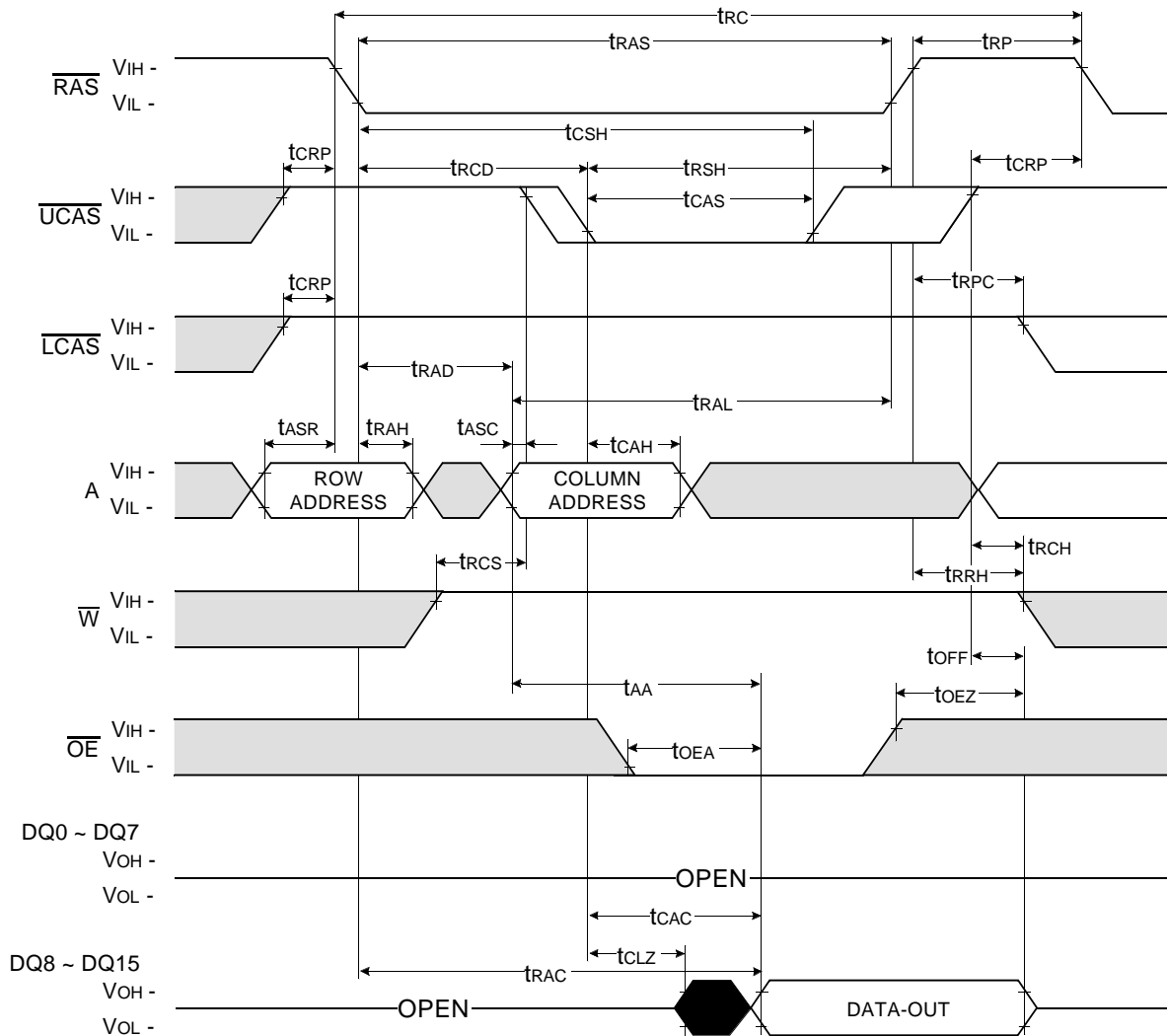

WORD WRITE CYCLE (EARLY WRITE)

NOTE : DOUT = OPEN

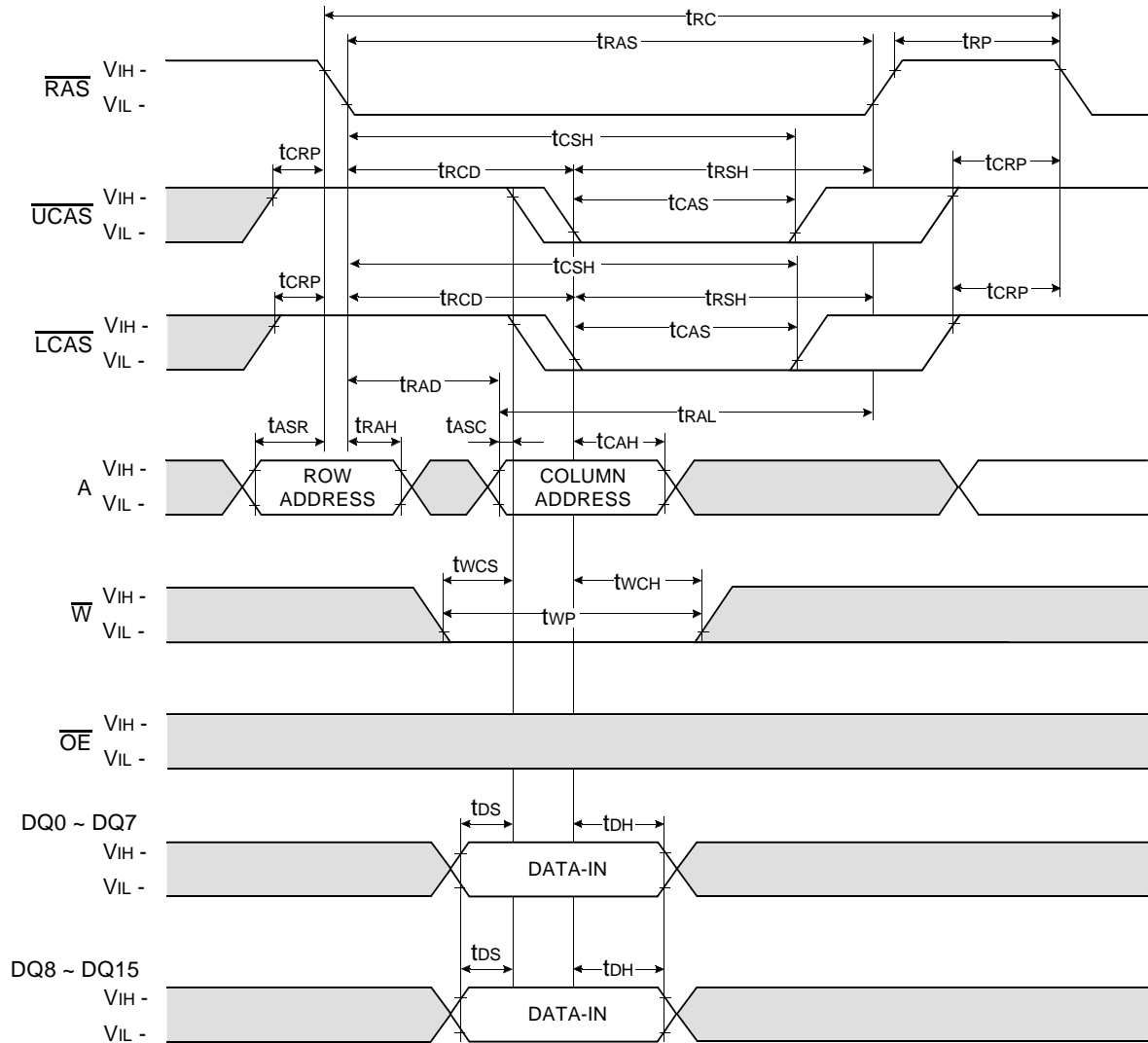

Don't care
 Undefined

LOWER BYTE WRITE CYCLE (EARLY WRITE)

NOTE : DOUT = OPEN

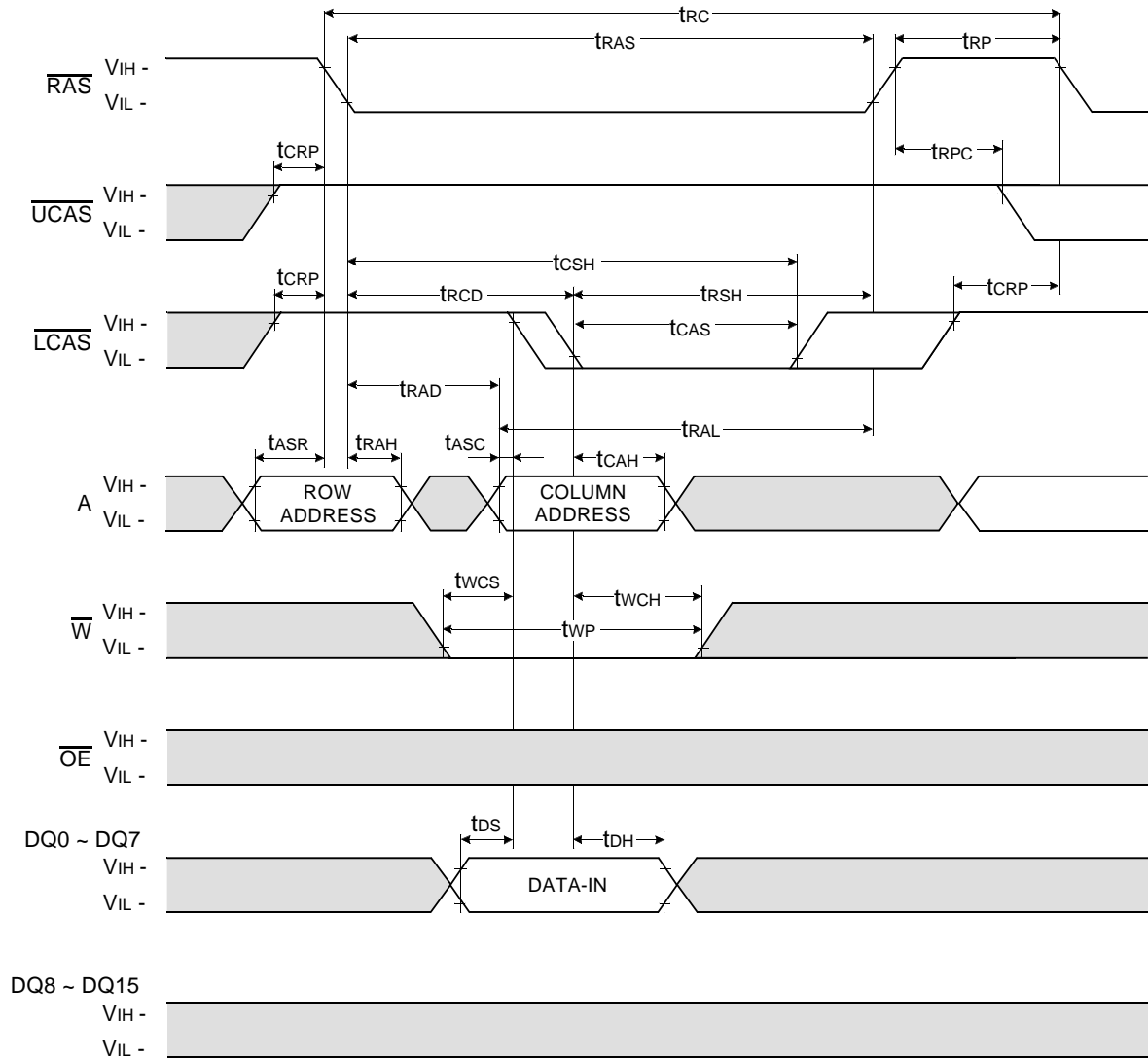

Don't care
 Undefined

UPPER BYTE WRITE CYCLE (EARLY WRITE)

NOTE : DOUT = OPEN

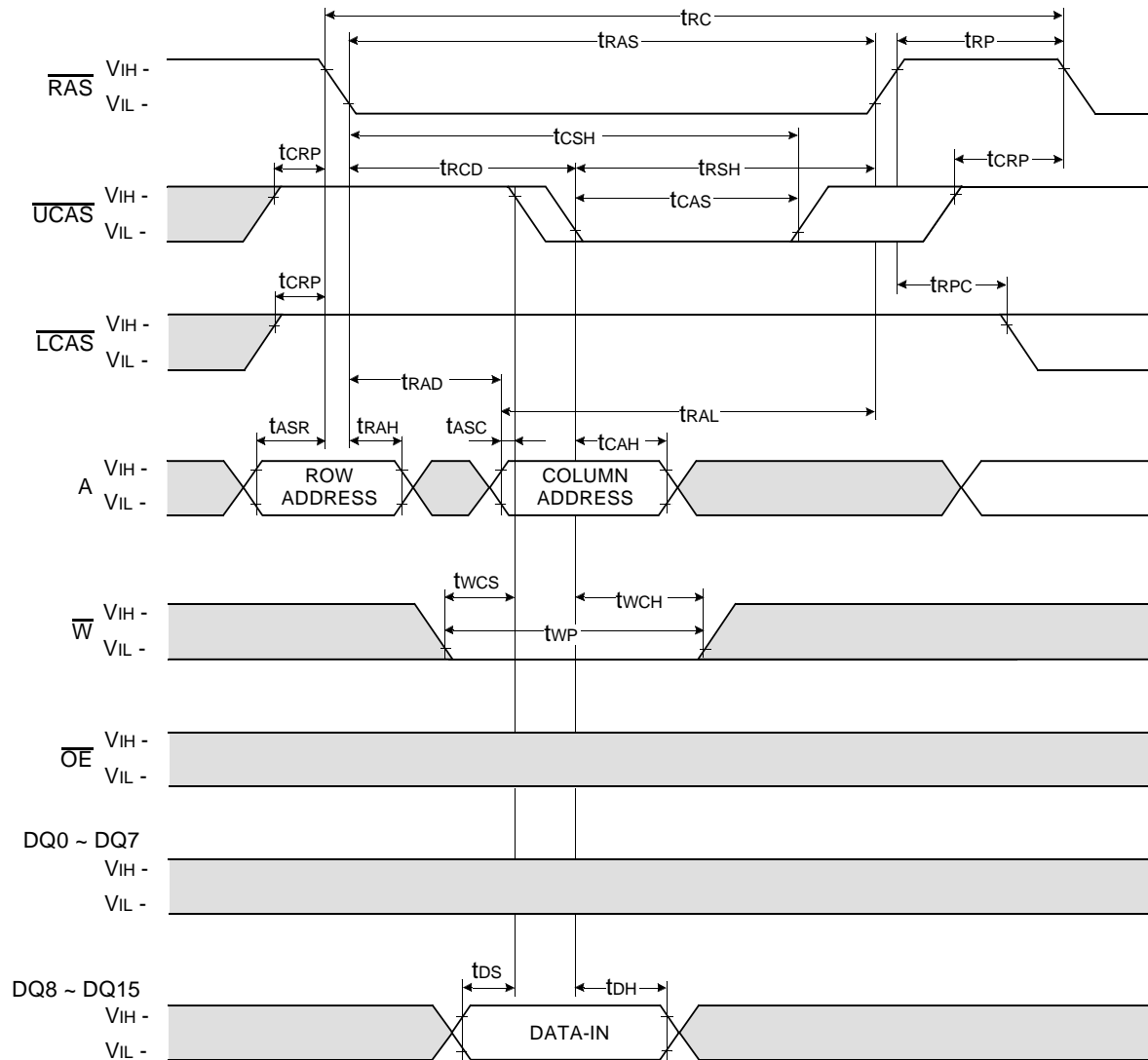

Don't care
 Undefined

WORD WRITE CYCLE (\overline{OE} CONTROLLED WRITE)

NOTE : DOUT = OPEN

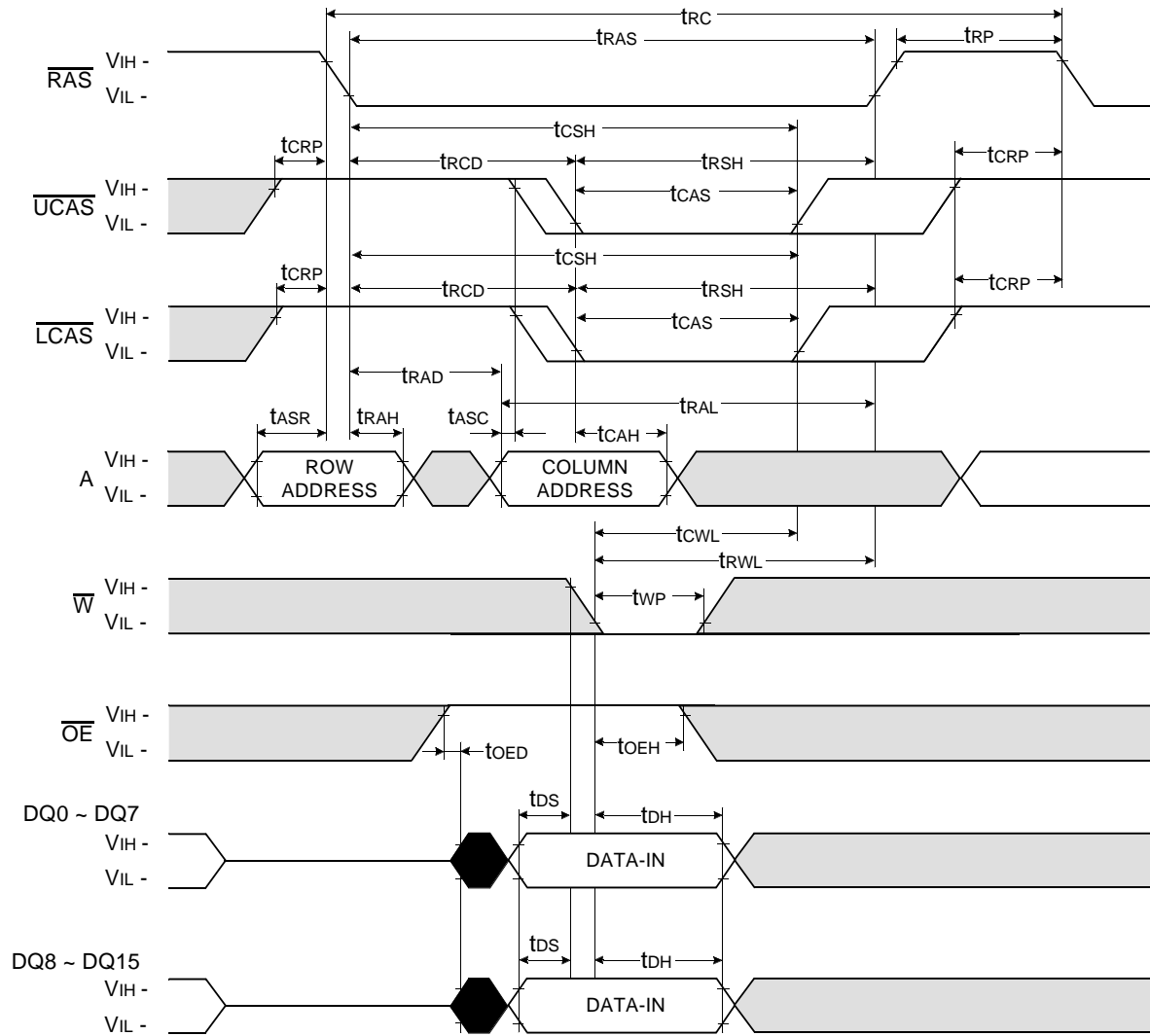

Don't care
 Undefined

LOWER BYTE WRITE CYCLE (\overline{OE} CONTROLLED WRITE)

NOTE : DOUT = OPEN

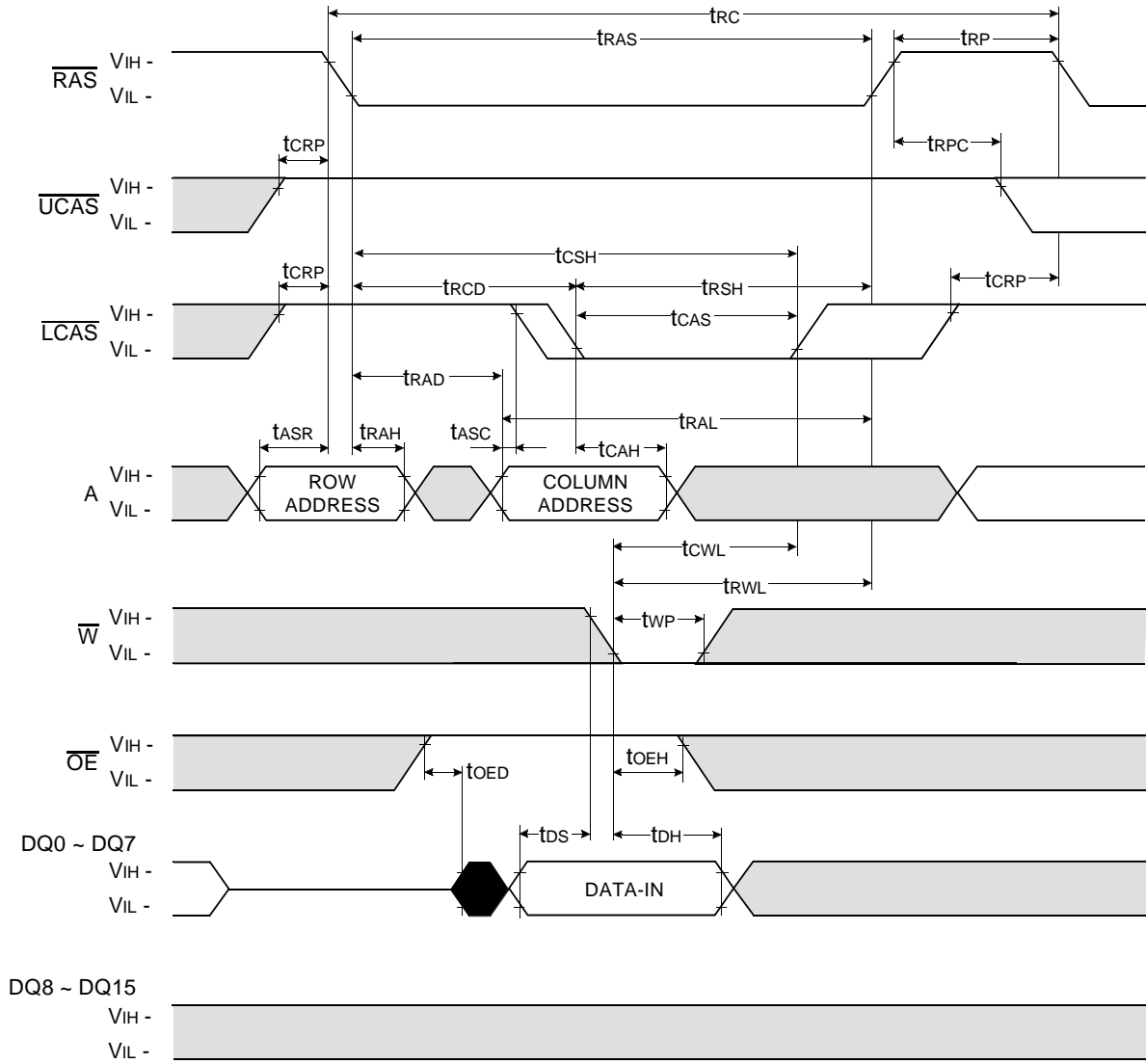

Don't care
 Undefined

UPPER BYTE WRITE CYCLE (\overline{OE} CONTROLLED WRITE)

NOTE : DOUT = OPEN

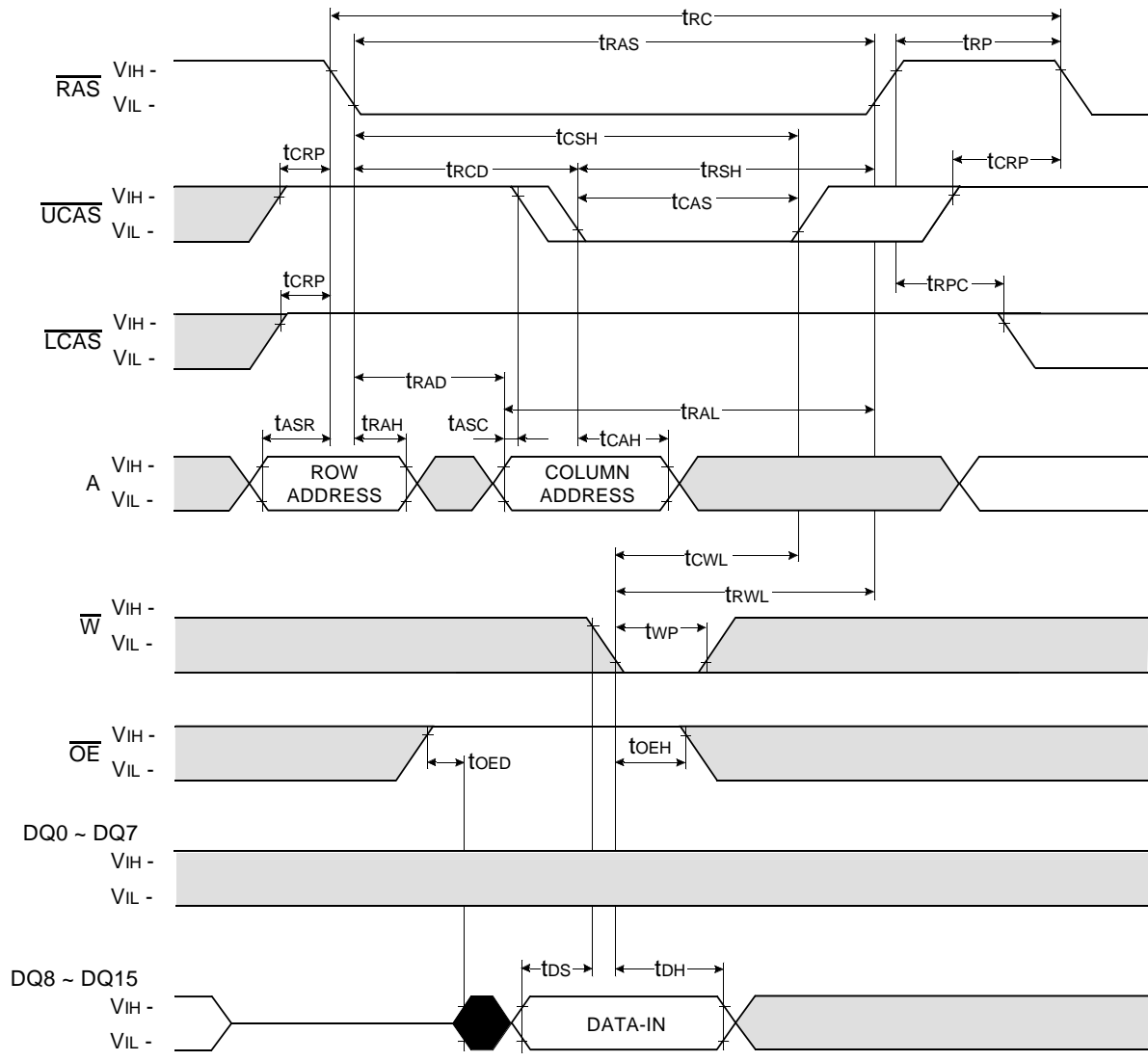

Don't care
 Undefined

WORD READ - MODIFY - WRITE CYCLE

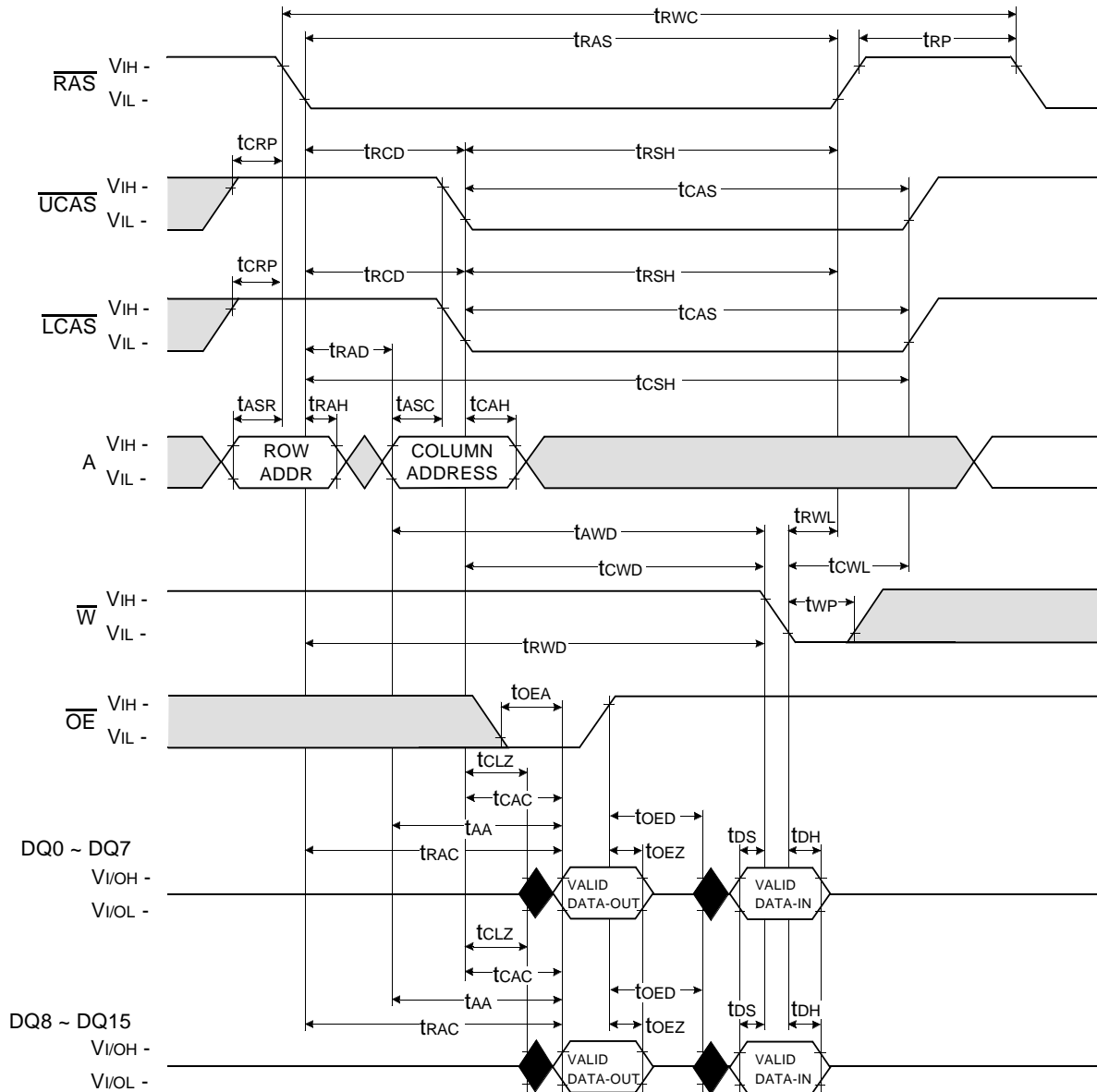

Don't care
 Undefined

LOWER-BYTE READ - MODIFY - WRITE CYCLE

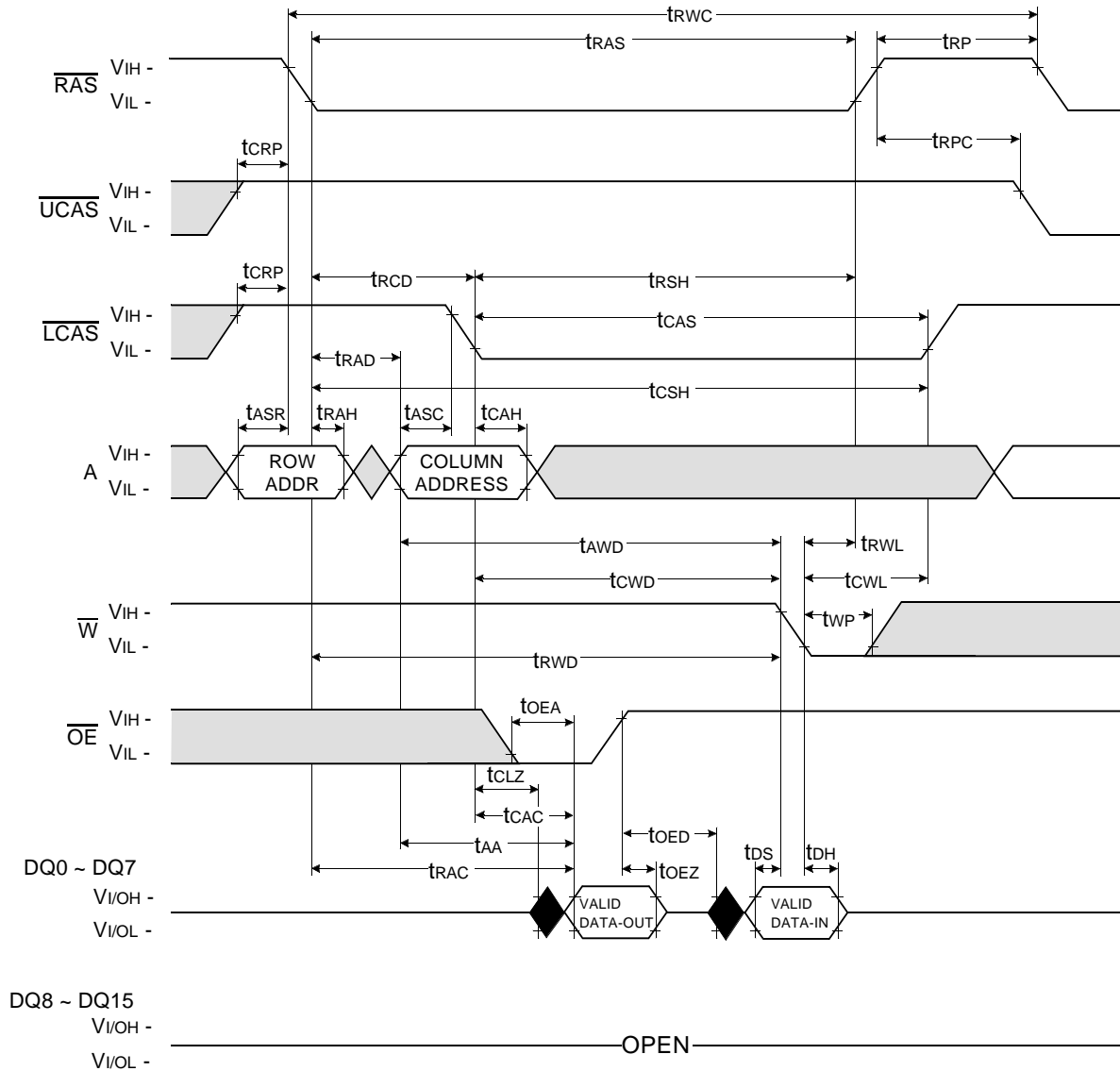

UPPER-BYTE READ - MODIFY - WRITE CYCLE

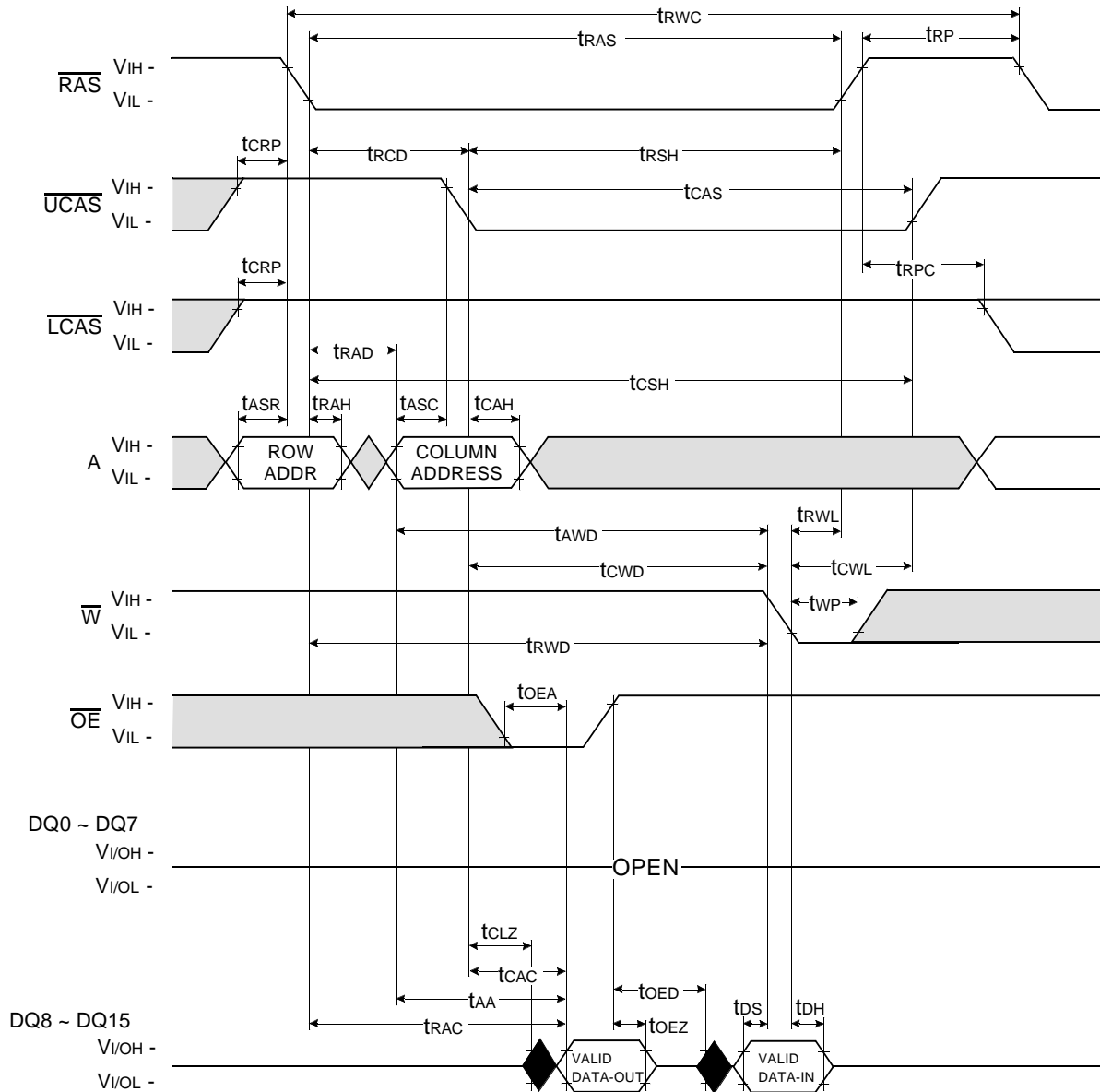

Don't care
 Undefined

FAST PAGE MODE WORD READ CYCLE

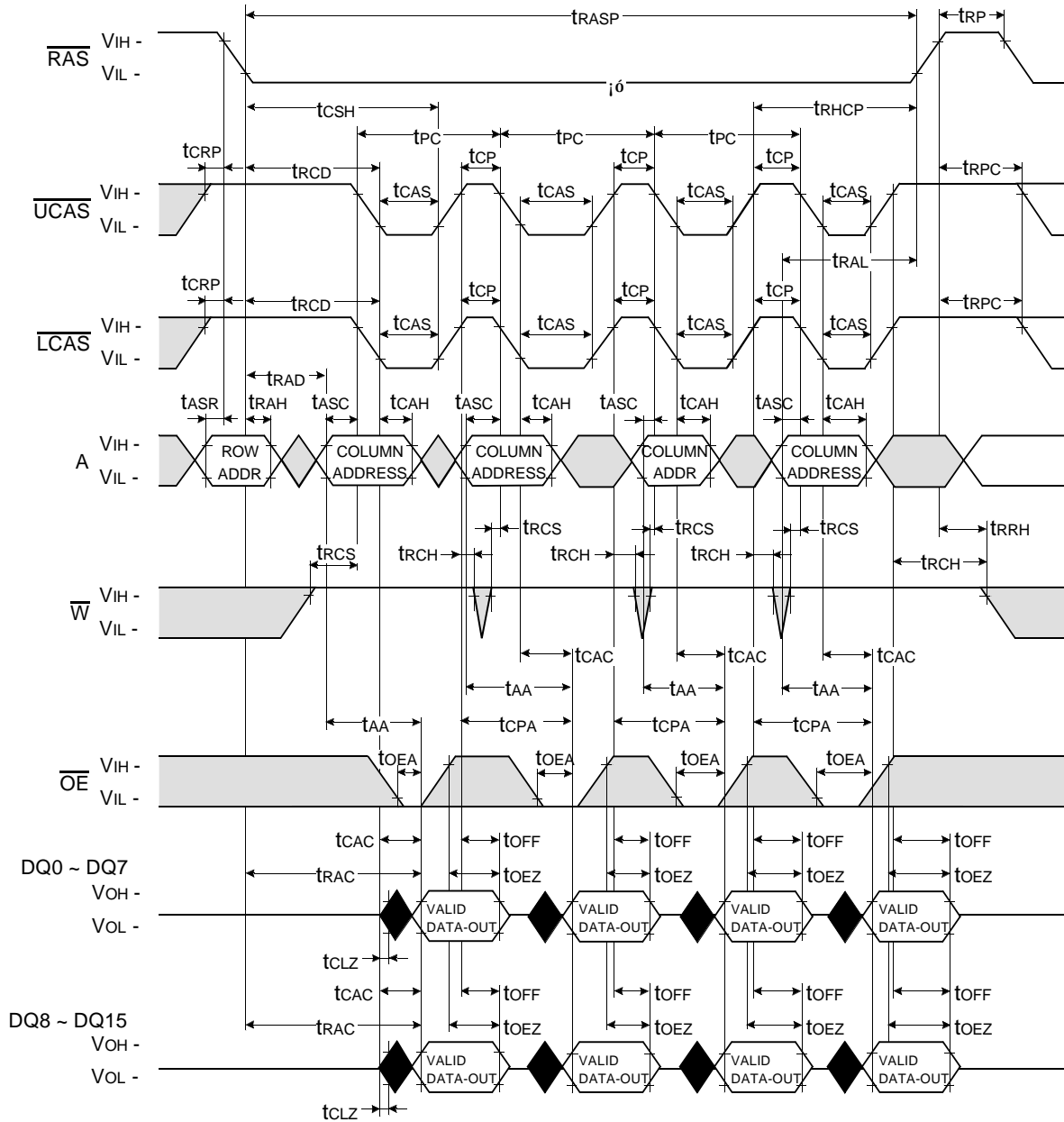

Don't care
 Undefined

FAST PAGE MODE LOWER BYTE READ CYCLE

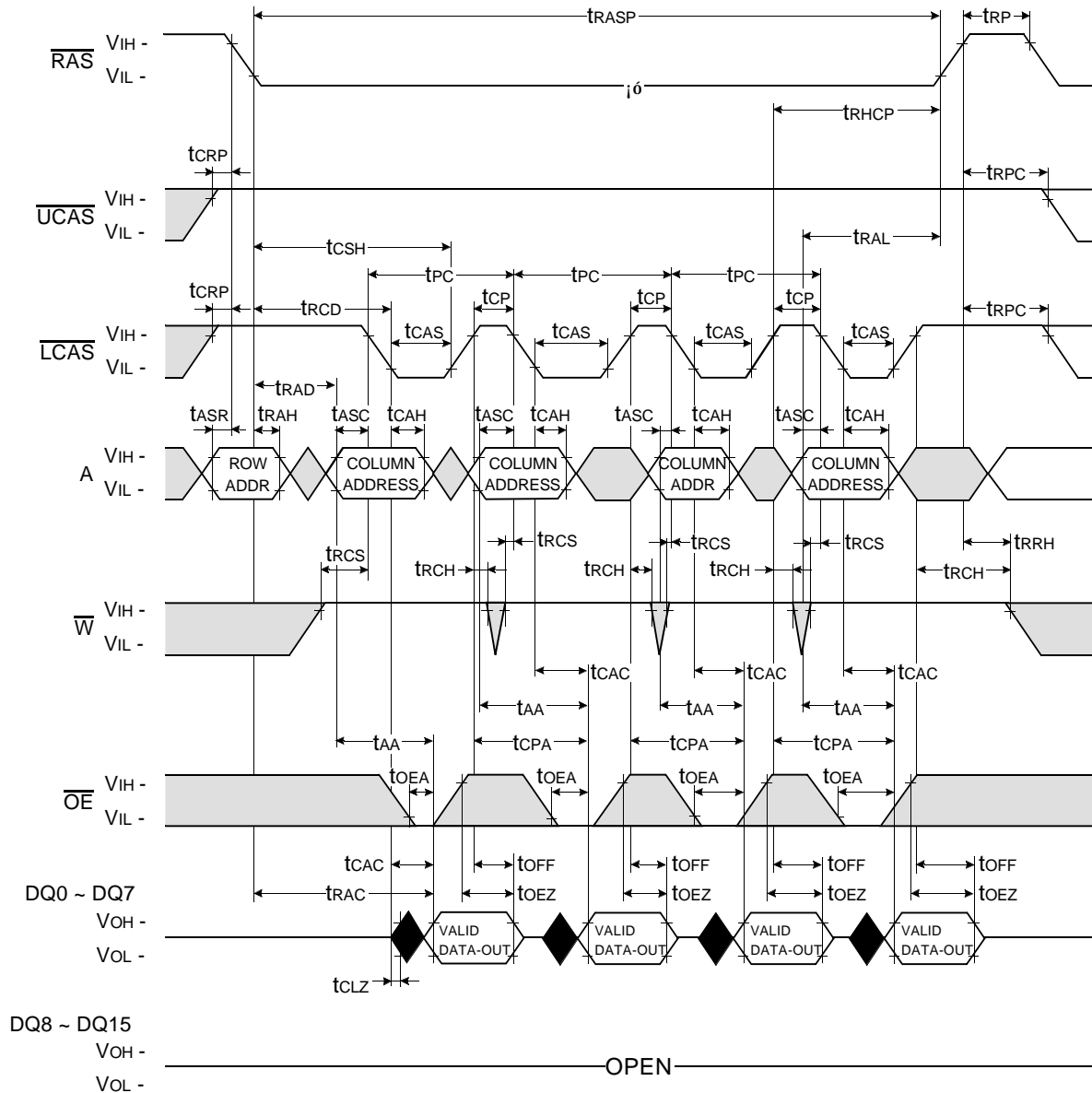

Don't care
 Undefined

FAST PAGE MODE UPPER BYTE READ CYCLE

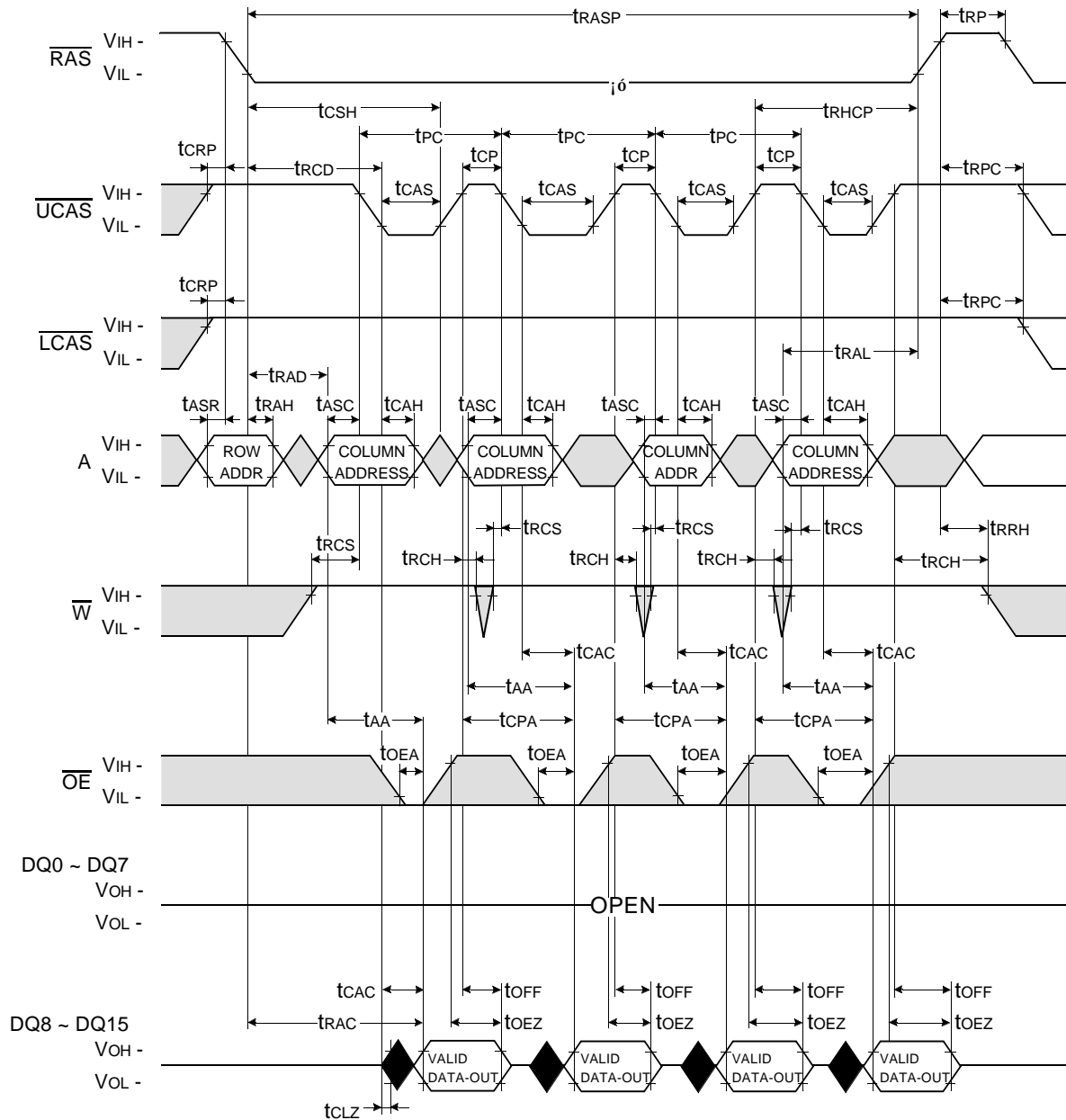

Don't care
 Undefined

FAST PAGE MODE WORD WRITE CYCLE (EARLY WRITE)

NOTE : DOUT = OPEN

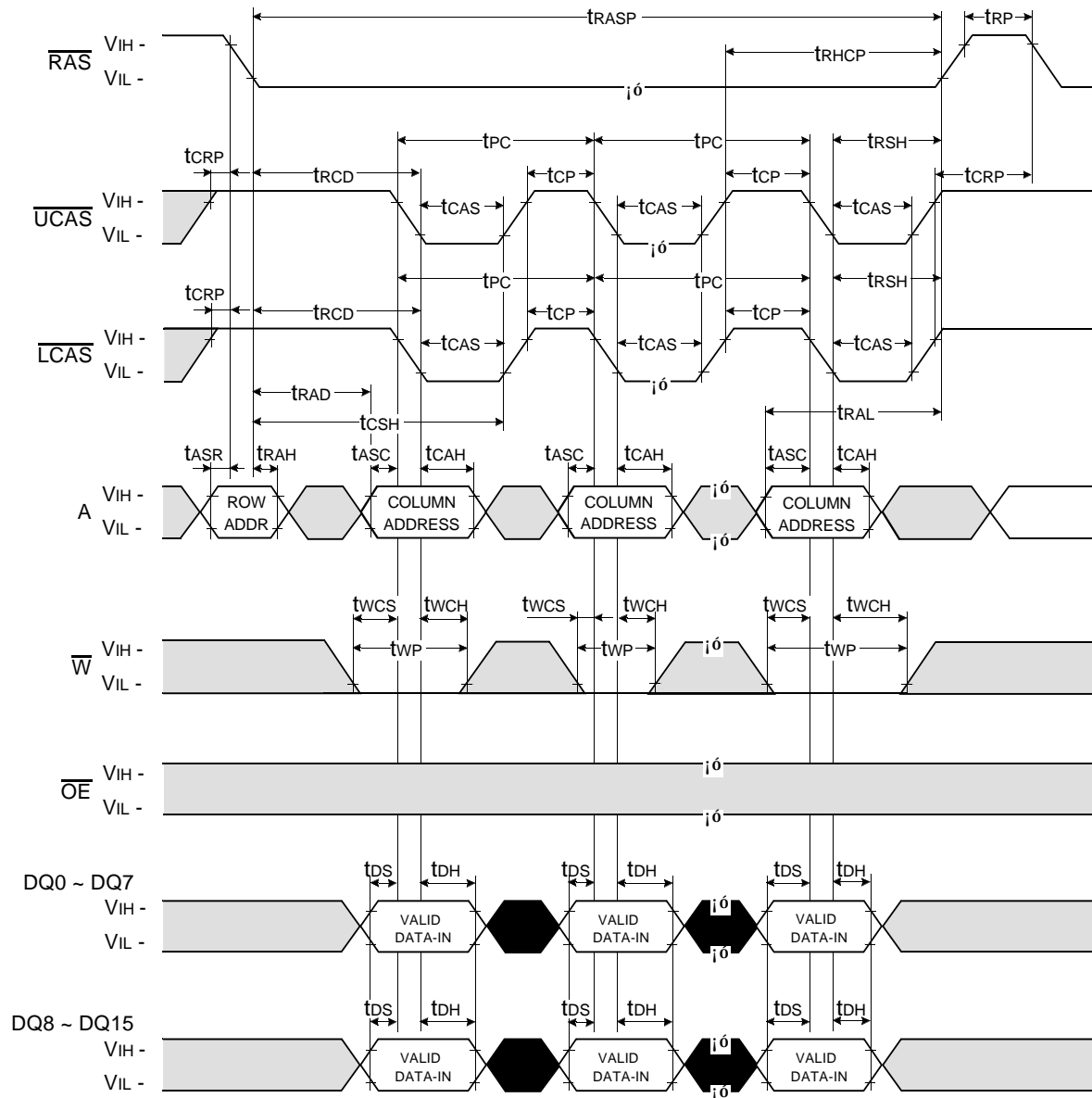

FAST PAGE MODE LOWER BYTE WRITE CYCLE (EARLY WRITE)

NOTE : DOUT = OPEN

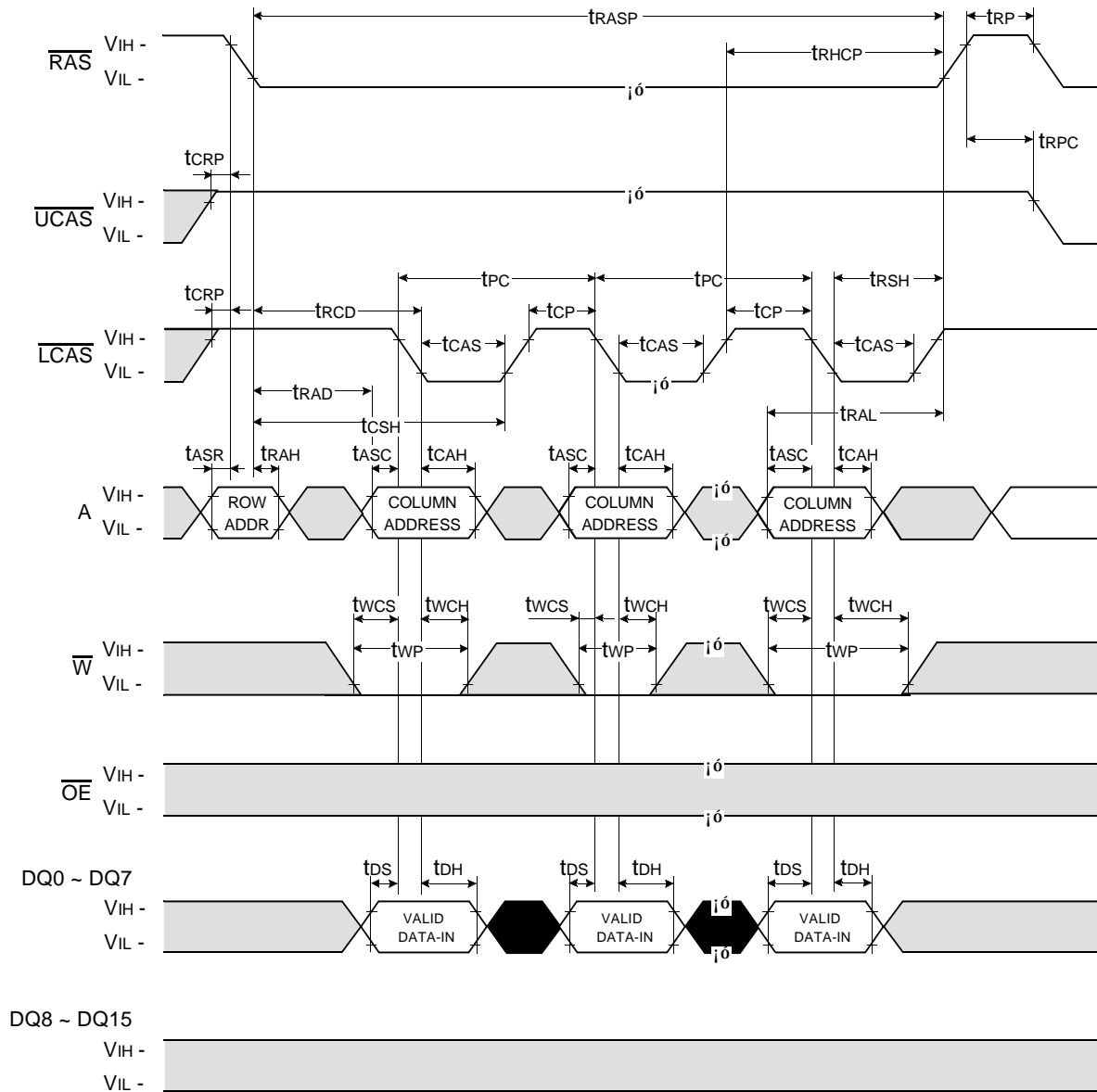

Don't care
 Undefined

FAST PAGE MODE UPPER BYTE WRITE CYCLE (EARLY WRITE)

NOTE : DOUT = OPEN

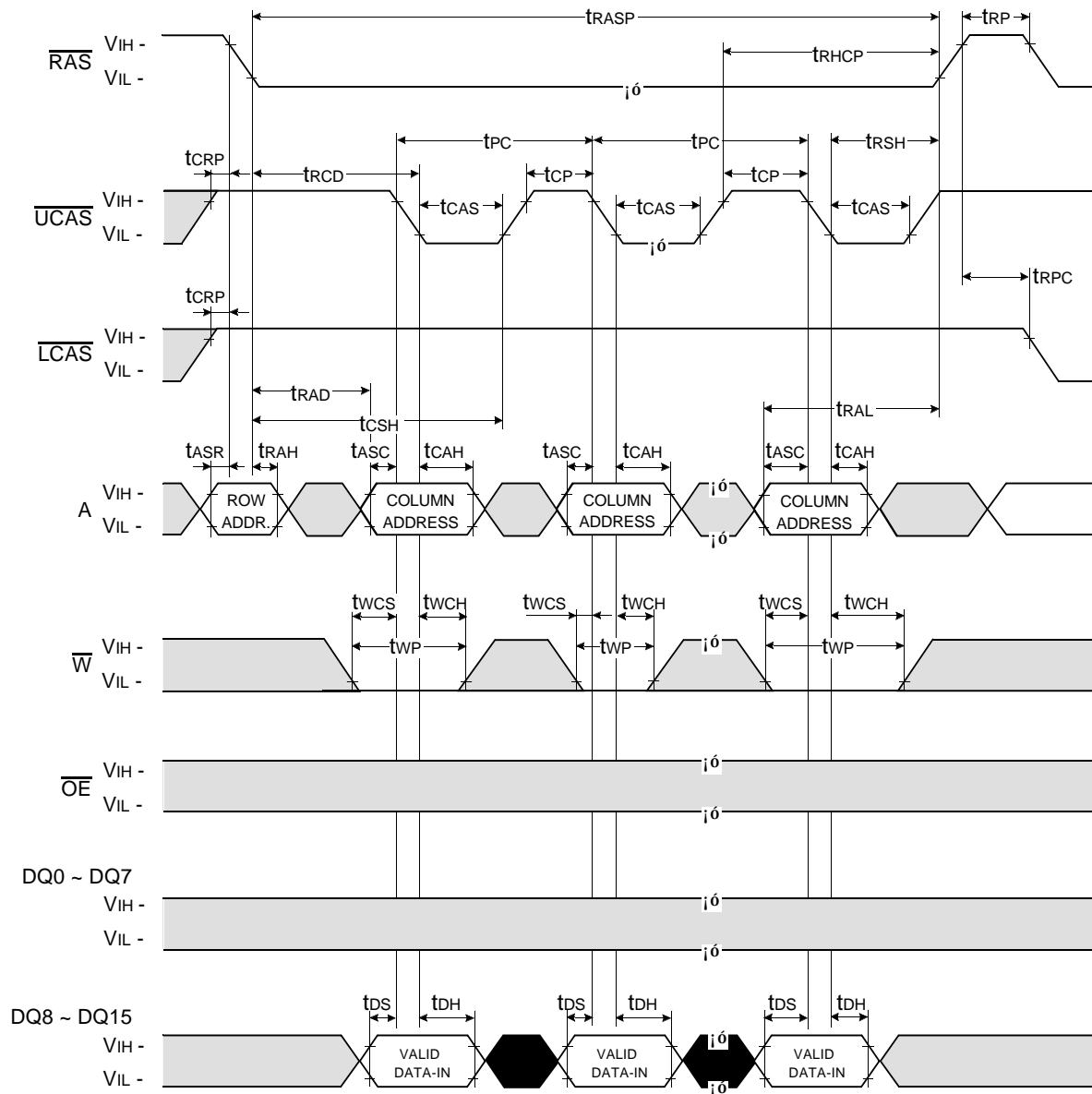

Don't care
 Undefined

FAST PAGE MODE WORD READ-MODIFY-WRITE CYCLE

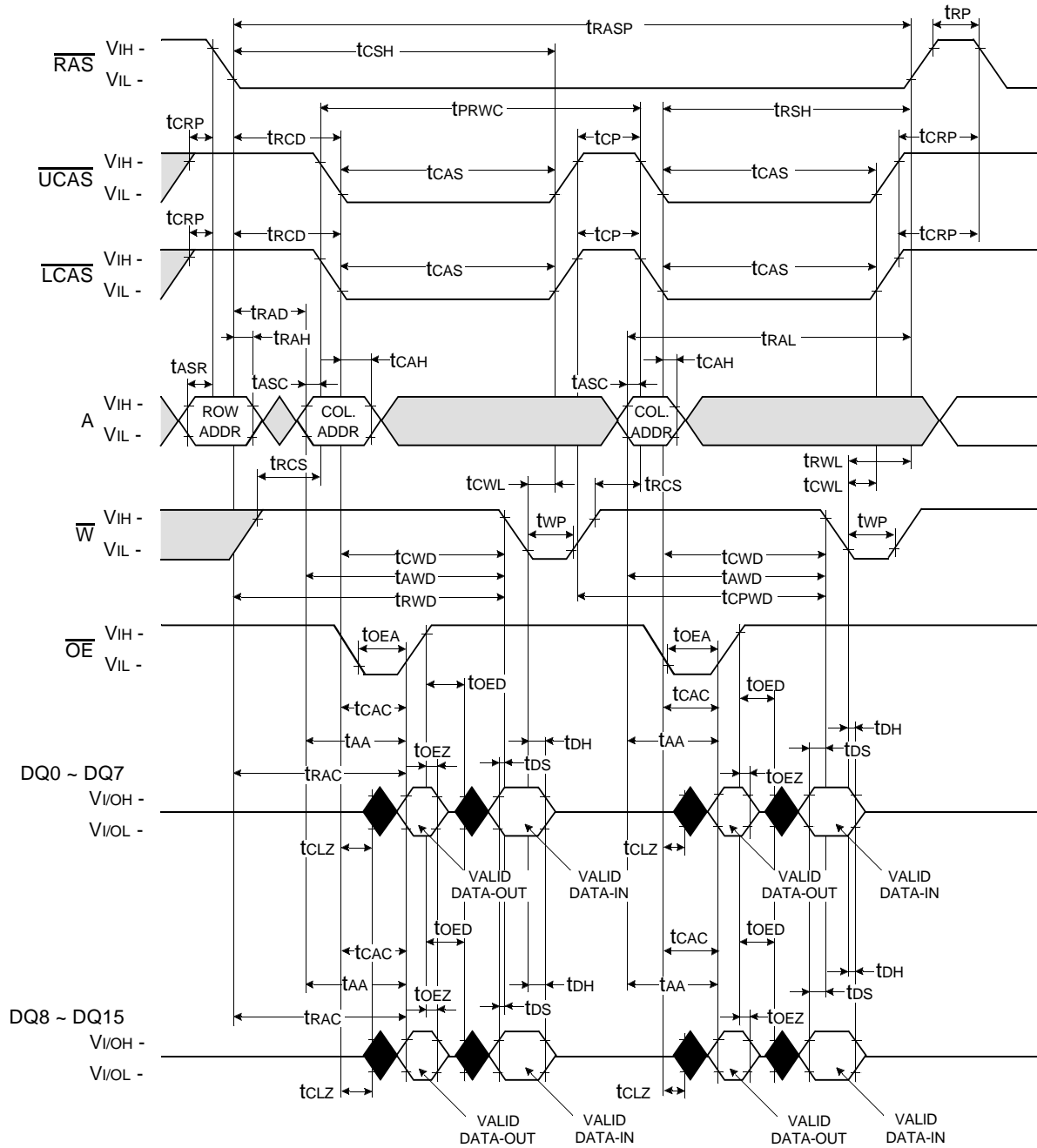

Don't care
 Undefined

FAST PAGE MODE LOWER BYTE READ - MODIFY - WRITE CYCLE

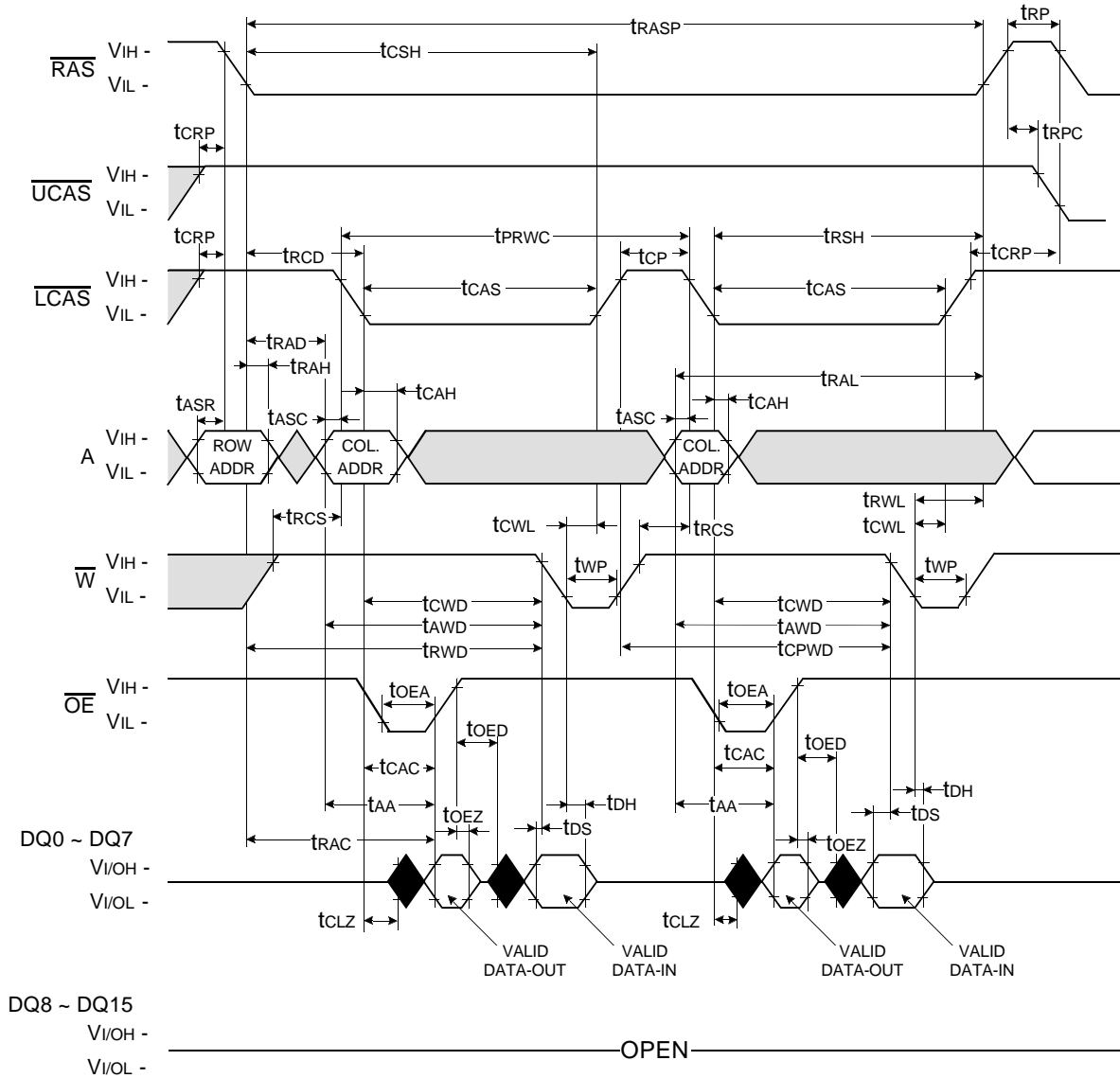

Don't care
 Undefined

FAST PAGE MODE UPPER BYTE READ - MODIFY - WRITE CYCLE

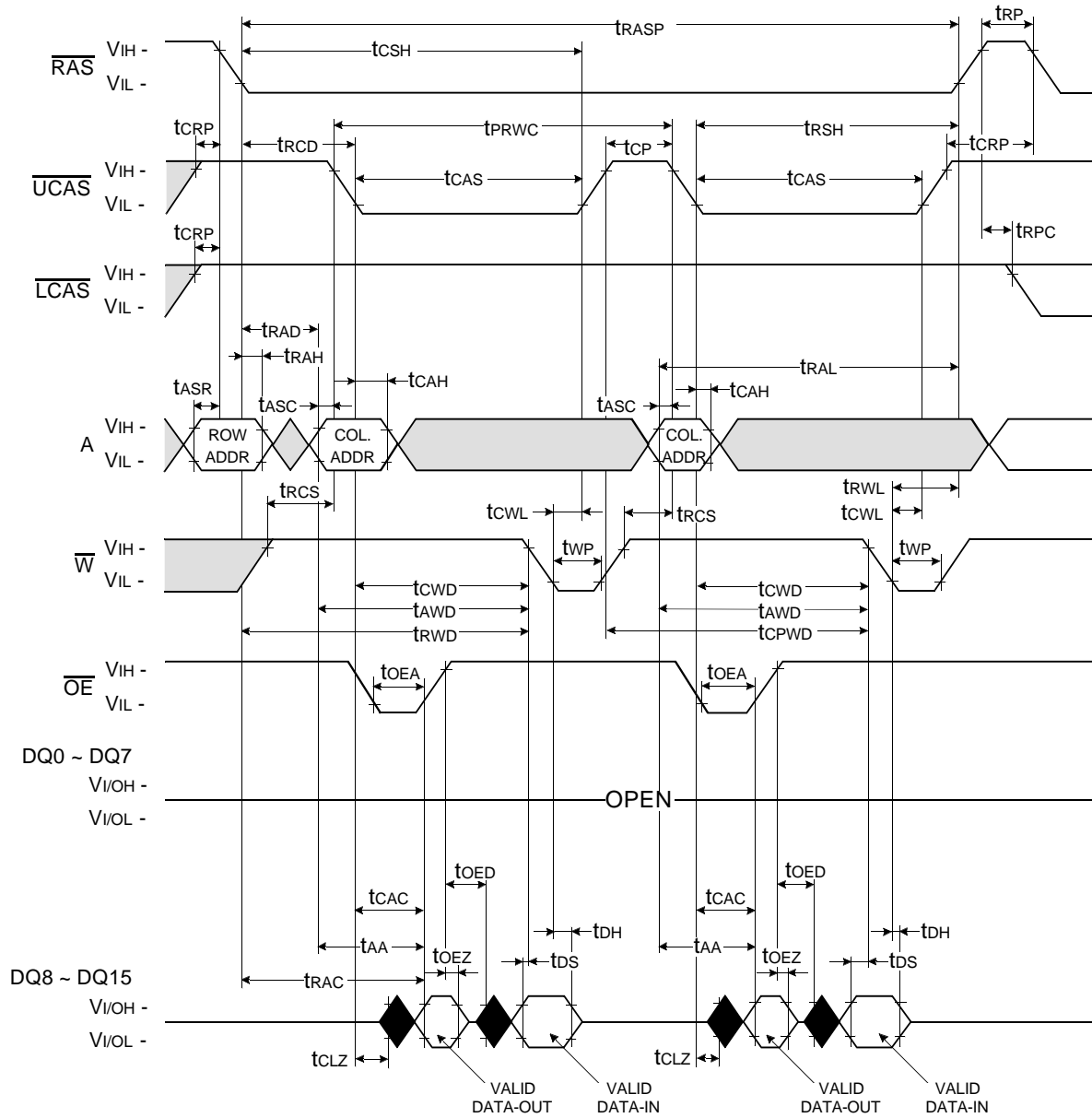

Don't care
 Undefined

$\overline{\text{RAS}}$ - ONLY REFRESH CYCLE

NOTE : $\overline{\text{W}}$, $\overline{\text{OE}}$, DIN = Don't care

DOUT = OPEN

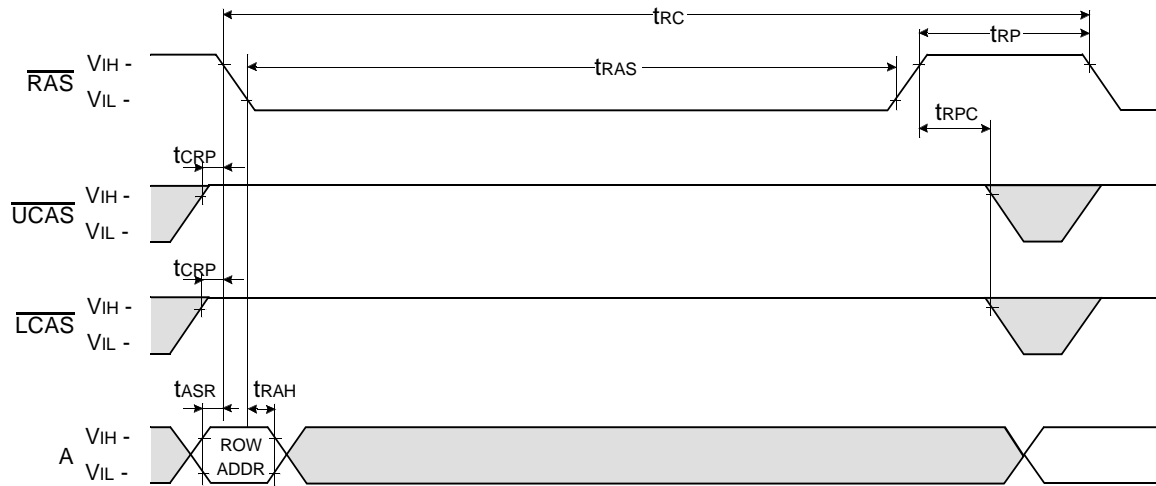

$\overline{\text{CAS}}$ - BEFORE - $\overline{\text{RAS}}$ REFRESH CYCLE

NOTE : $\overline{\text{OE}}$, A = Don't care

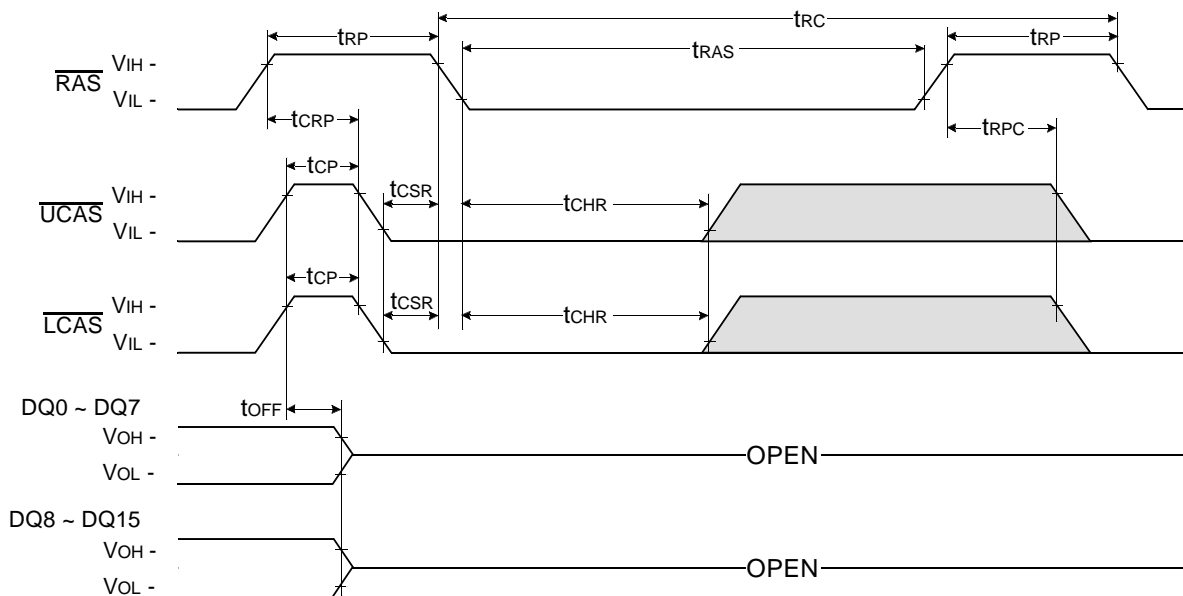

Don't care
 Undefined

HIDDEN REFRESH CYCLE (READ)

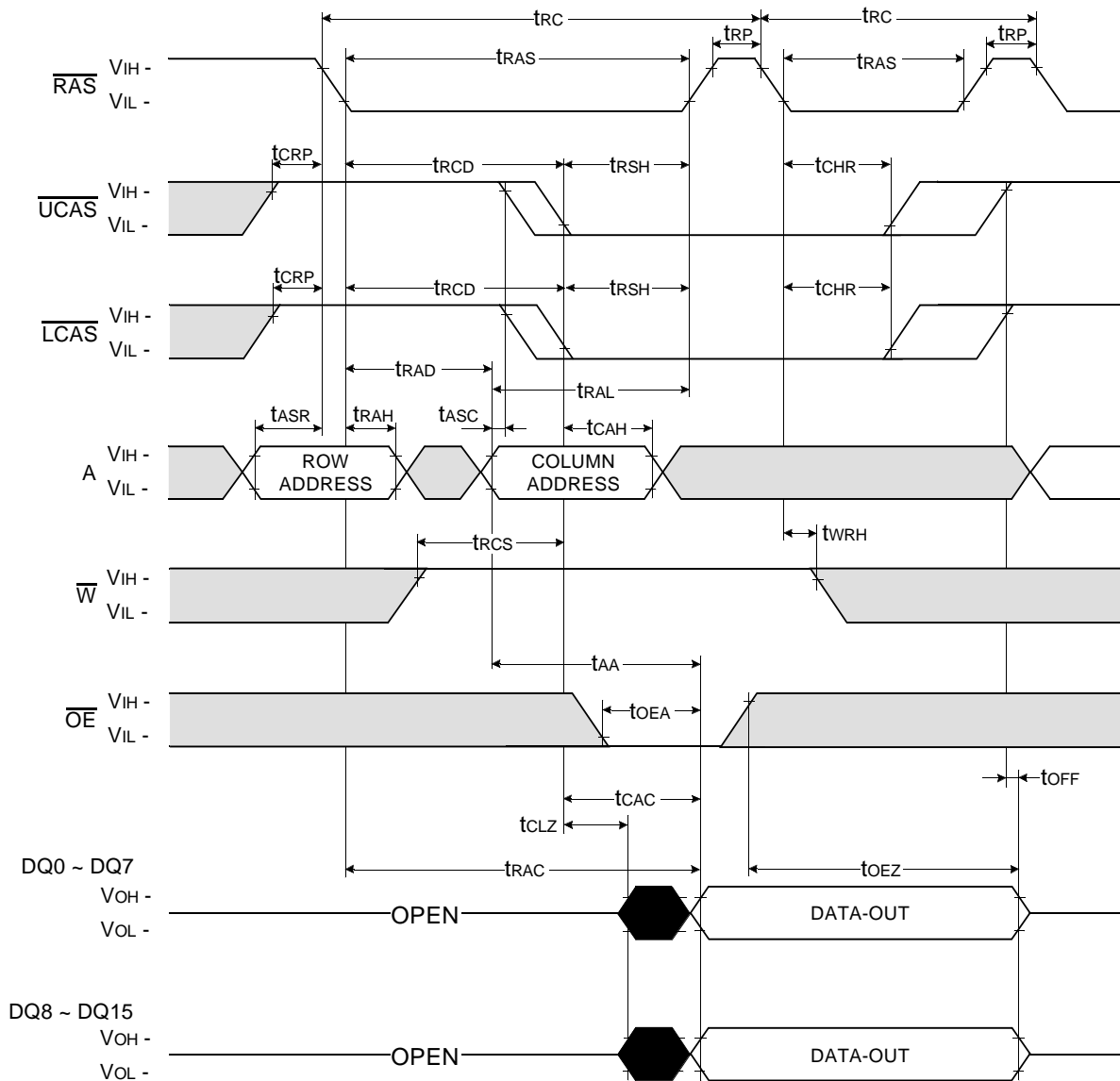

Don't care
 Undefined

HIDDEN REFRESH CYCLE (WRITE)

NOTE : DOUT = OPEN

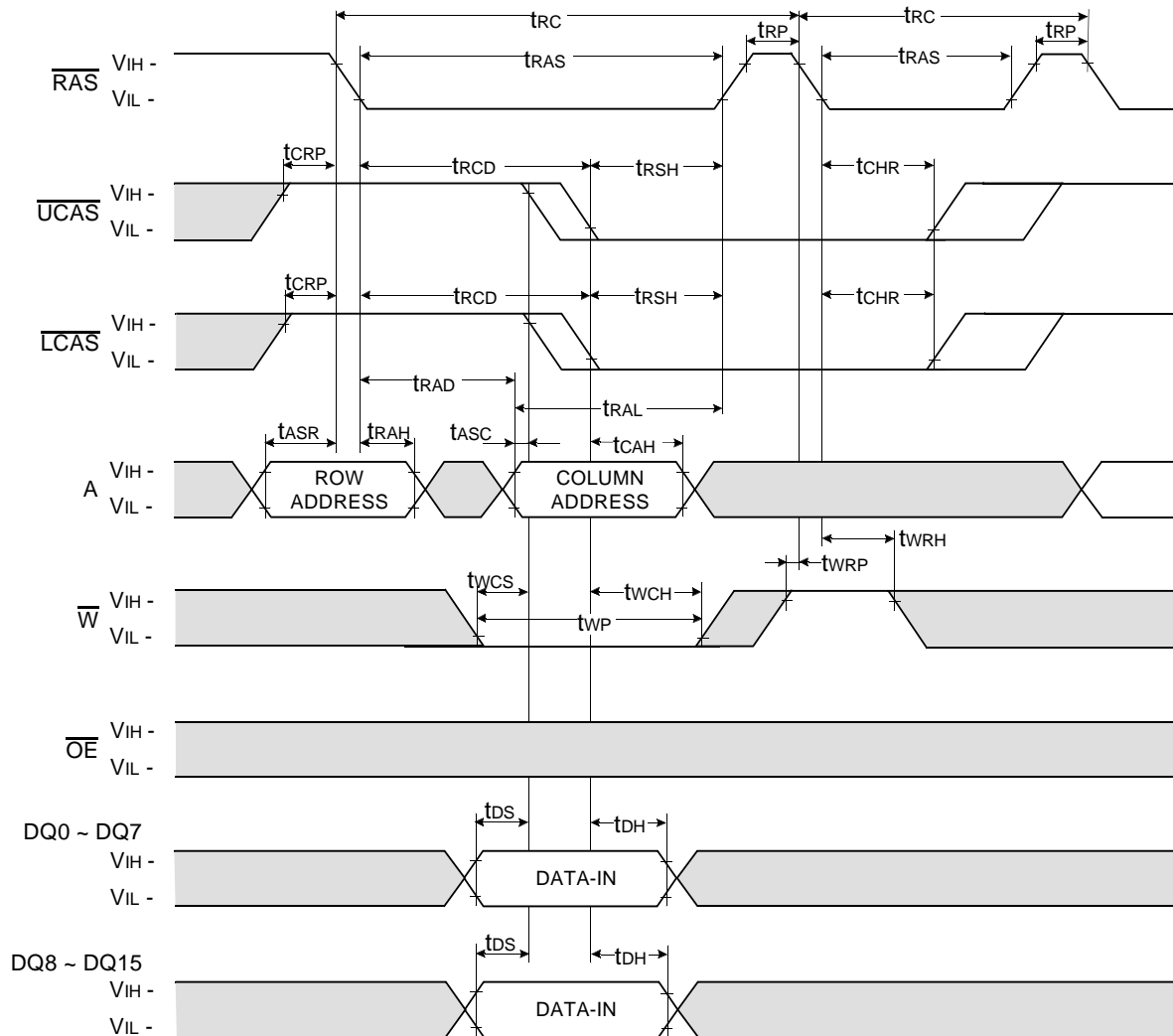

Don't care
 Undefined

CAS-BEFORE-RAS REFRESH CYCLE

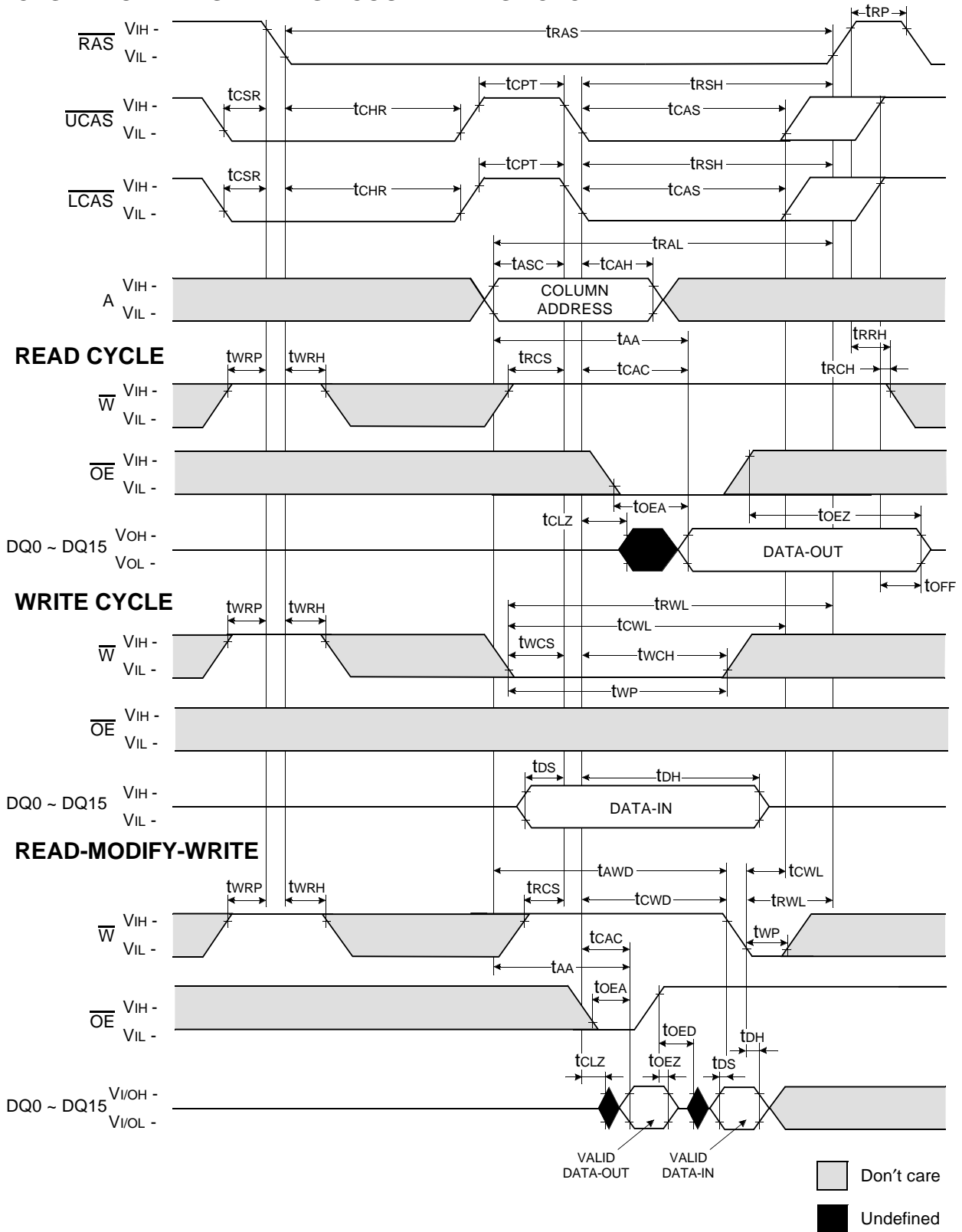

$\overline{\text{CAS}}$ - BEFORE - $\overline{\text{RAS}}$ SELF REFRESH CYCLE

NOTE : $\overline{\text{OE}}$, A = Don't care

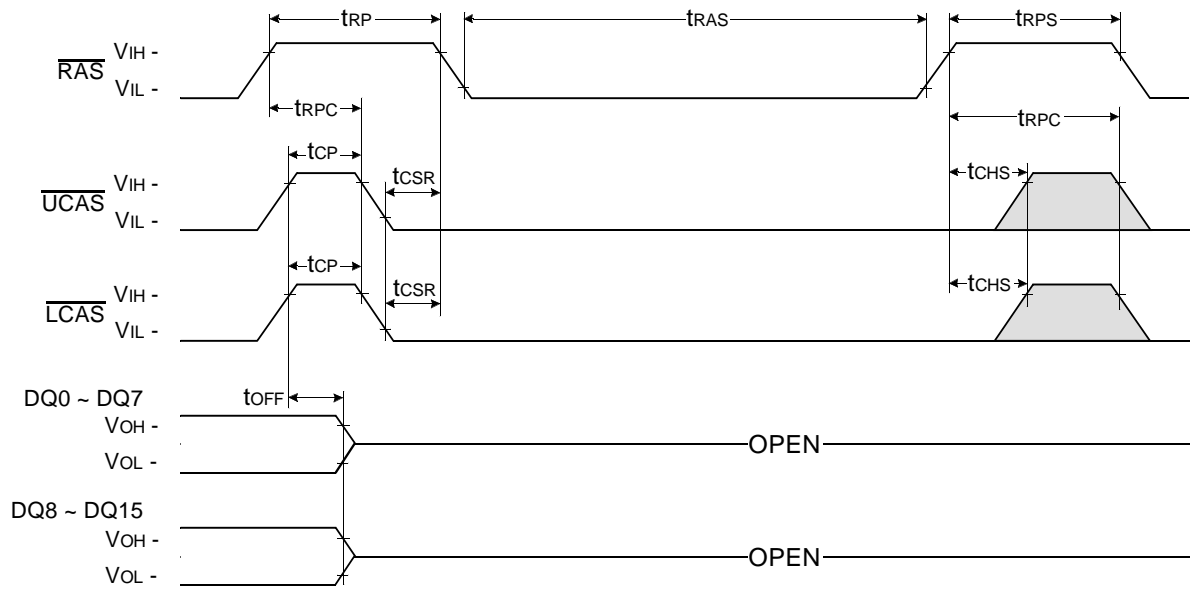

Don't care
 Undefined

PACKAGE DIMENSION

