

UNIVERSAL SINK DRIVER

■ GENERAL DESCRIPTION

NJM3545 is a bipolar universal high-current highly protected low side driver with transparent input and 2000mA continuous -current sink capability. A high-level input activates the output.

The driver is equipped with extensive electrical protection; such as over current protection and thermal protection, which makes the device virtually indestructible.

Furthermore it can detect open circuit and short circuit to ground.

A special feature is the Error indicating output function pin which signals to the host system if the protection or the load check functions is activated.

The NJM3545 and NJM3548 are complementary drivers and have similar data.

■ PACKAGE OUTLINE

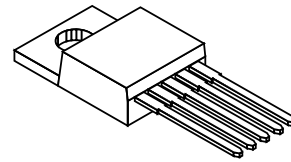

NJM3545TA2

■ FEATURES

- 2000mA continuous-output current
- Short circuit to V_{CC} protection
- Error signal to host system
- Open circuit detection
- Short circuit to ground detection
- Thermal protection
- Built-in protection diodes
- Package TO-220 (5-pin)

■ BLOCK DIAGRAM

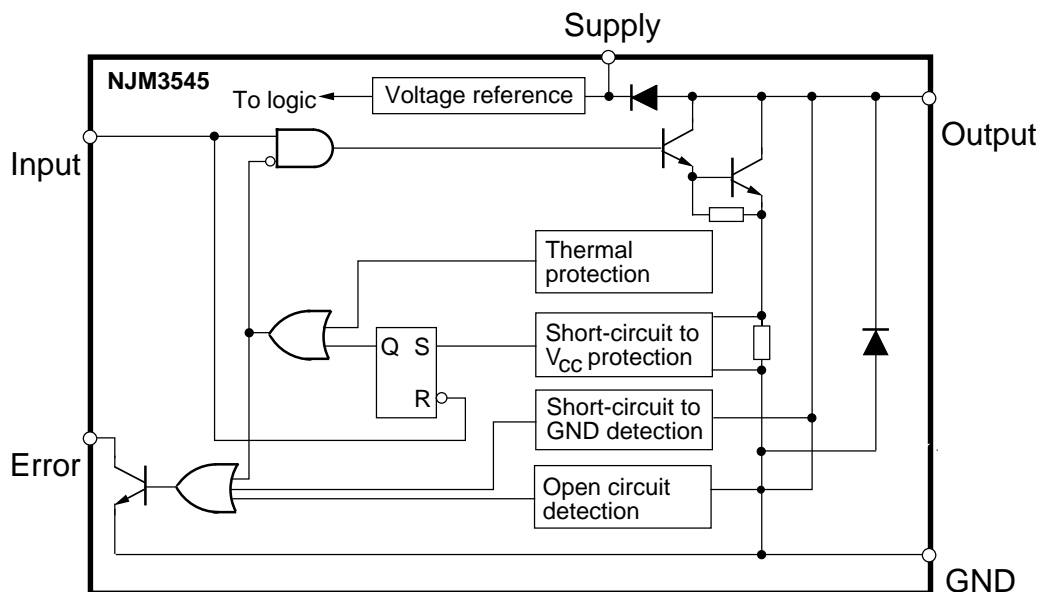

Figure 1. Block Diagram

PIN CONFIGURATION

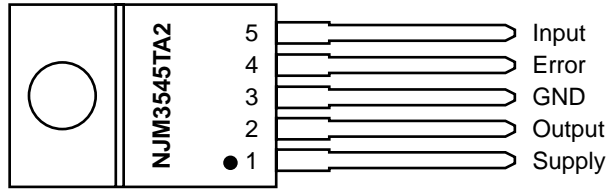

Figure 2. Pin description

PIN DESCRIPTION

TO-220	Symbol	Description
1	Supply	Supply voltage. Nominally 5 V to 40 V.
2	Output	Output pin. Current flows from supply through the load into the pin. Nominal current is 8 mA to 2 A.
3	GND	Ground supply.
4	Error	diode are bonded to a separate pin. Error indicating pin. Sinks current to ground if the protection and/or detection circuitry is activated. Note: the current must be externally limited to 8 mA.
5	Input	TTL compatible input. A LOW input signal turns the output transistor off and a HIGH input turns it on.

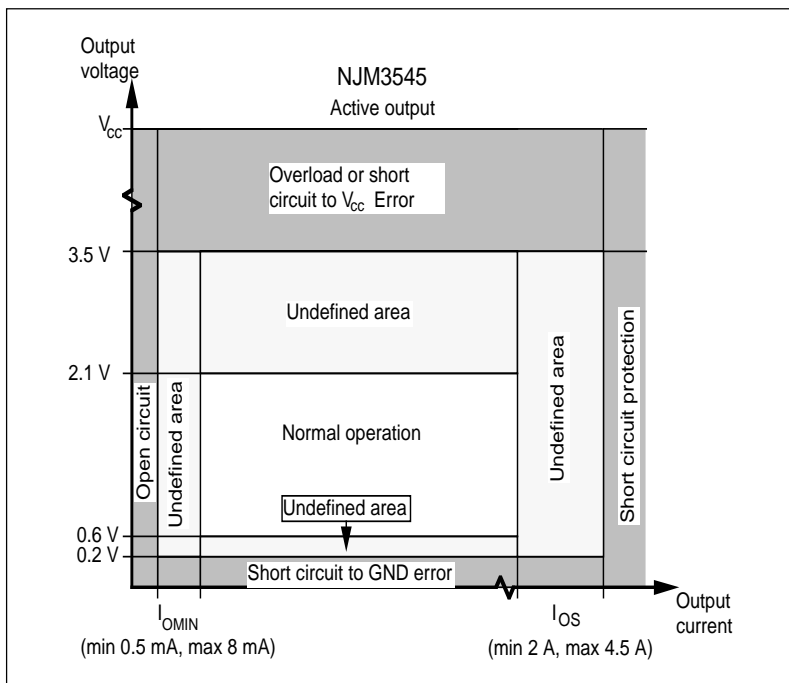

Figure 3. Error state vs. output voltage and output current, active output ($2.0 \leq V_{IN} \leq V_{CC}$), $5 \text{ V} < V_{CC} < 40 \text{ V}$, $-40^\circ\text{C} < T_J < +100^\circ\text{C}$

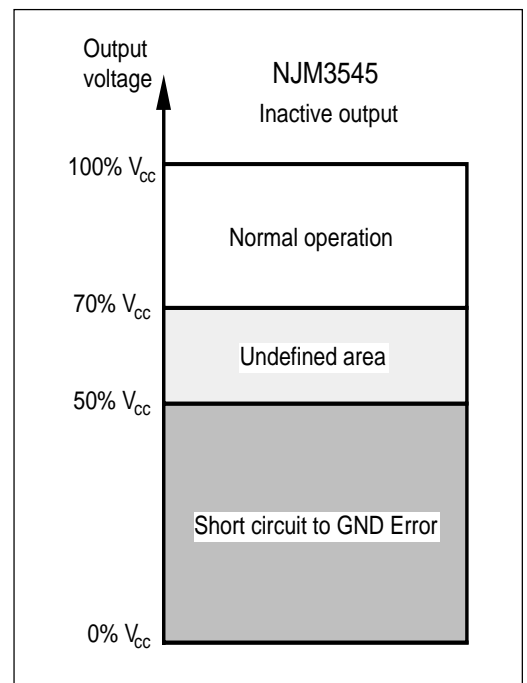

Figure 4. Error state vs. output voltage, inactive output ($0 \text{ V} \leq V_{IN} \leq 0.8 \text{ V}$), $5 \text{ V} \leq V_{CC} \leq 40 \text{ V}$, $-40^\circ\text{C} < T_J < +100^\circ\text{C}$

FUNCTIONAL DESCRIPTION

The circuit NJM3545 is a low side driver capable of driving resistive or inductive loads not exceeding 2 A.

The driver has an error indicating function which generates an Error output signal when a fault condition has occurred.

The circuits NJM3545 and NJM3548 are complementary drivers with equivalent functions and similar data. NJM3545 is a sink driver and NJM3548 is a source driver.

Input stage

The output stage is switched on and off according to the status of the input. HIGH level activates the output. If the input is left open, the circuit will accept it as a LOW level.

Output stage

The output stage contains a power transistor and two clamping diodes. The diodes are used for terminating line transients from inductive loads. If the driver is inactive and the output is shorted to GND the driver will leak maximum

8 μ A. See figure 18.

Protection circuit

The circuit contains two protection circuits:

- Overload and Short circuit protection
- Thermal protection

The overload and short circuit protection will be activated at $I_{out} = 3.5$ A typically at $T_j = +25^\circ\text{C}$, see figure 20.

The output will be turned off immediately and latched to a high-impedance state after an overload or short circuit has been detected.

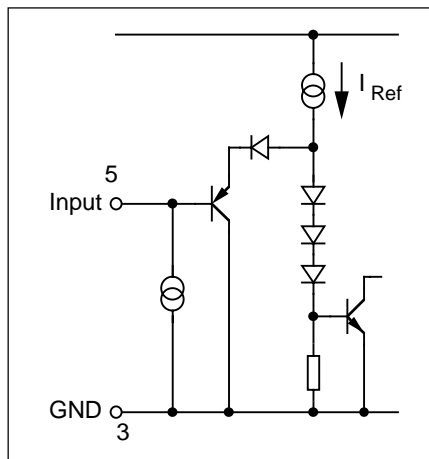

Figure 5. Input stage

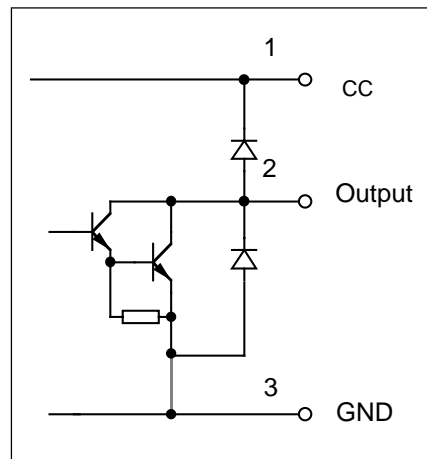

Figure 6. Output stage

Fault condition	Input	Output	Error LOW=Error HIGH=Normal	How to resume normal operation
Normal	0 LOW 1 HIGH	1 OFF 0 ON	1 HIGH 1 HIGH	— —
V_{OUT} Short to GND	0 LOW 1 HIGH	1 OFF 0 ON	0 LOW 0 LOW	Remove fault condition. Remove fault condition.
V_{OUT} Short to V_{CC}	0 LOW 1 HIGH	1 OFF 1 OFF	1 HIGH 0 LOW	— Turn off and on after fault condition is removed.
Open load	0 LOW 1 HIGH	1 OFF 0 ON	1 HIGH 0 LOW	— Attach proper load to output or turn off the driver.
Over temperature $T_j = 130^\circ\text{C}$	0 LOW 1 HIGH	1 OFF 1 OFF	1 HIGH 0 LOW	— Temperature is reduced to approx 120°C , or turn off the driver.

Figure 7. Error table

A logic-level change at the input will reset the internal error latch. If the fault still is present at turn-on, the circuit will once again turn the output off.

Due to a slight delay in the circuit, a high current transient will occur when the output is shorted to V_{cc} . This current transient may reach 8 A during 5 μ s. Consequently, switching at high frequencies with a shorted output may destroy the circuit. If a short circuit condition is detected, stop switching the input and remove fault condition.

Thermal protection

The output of NJM3545 is equipped with a thermal shut-down function, that turns the outputs off at a chip (junction) temperature above typically 130°C.

Normal operation is resumed when the temperature has decreased about 20C.

Error functions

The Error indicating signal occurs on a separate pin. The complete error table is shown in figure 7.

The following conditions generate an error signal:

When the driver is activated and at least one of the following conditions has occurred:

- thermal overload
- short circuit to GND
- short circuit to V_{cc}
- open circuit

An output current less than 8 mA might be detected as “open circuit”. Output currents larger than 8 mA and less than 2 A will definitely not generate an error. The normal operational area is shown in figure 3.

Also when the driver is inactivated an Error indication can occur. That is if the output is shorted to GND. In figure 4 short circuit to GND Error state versus output voltage is shown.

When the Error-detection function is activated, the Error output is capable of sinking 8 mA, supporting direct connection of an LED. The current has to be externally limited by a series resistor.

Signal diagrams

The signal diagram in figure 8 shows the input signal and the resulting output signals for each error mode. For details, see error table, figure 7.

V_{IN} = Input voltage. Active = HIGH.

V_{OUT} = Output voltage.

I_{OUT} = Output current from driver.

V_{ERR} = Error output voltage.

Error = LOW.

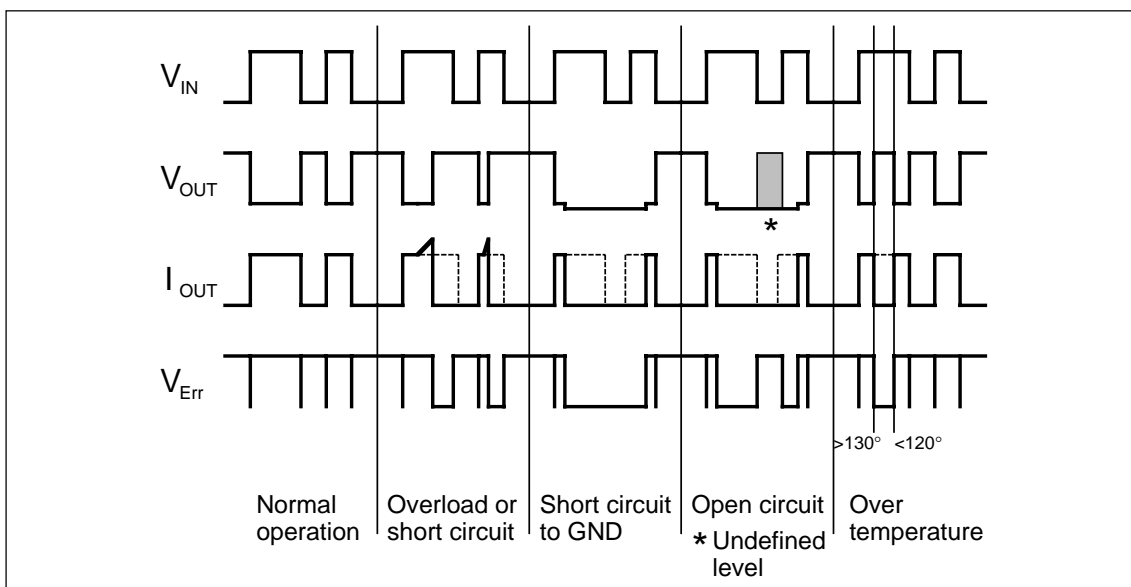

Figure 8. Signal diagram

■ ABSOLUTE MAXIMUM RATINGS

Parameter	Pin no.	Symbol	Min	Max	Unit
Voltage					
Supply voltage	1	V_{CC}	0	45	V
Logic input voltage	5	V_{IN}	-0.3	V_{CC}	V
Current					
Logic input current	5	I_{IN}	-10	-	mA
Continuous DC Operation output current TO-220	2	I_{OUT}	-	2000	mA
Error output current	4	I_{ERR}	-	10	mA
Temperature					
Operating junction temperature (internally limited)		T_J	-	+140	°C
Storage temperature		T_S	-40	+150	°C
Power Dissipation (Package Data)					
Power dissipation at $T_{Case} = 85^\circ\text{C}$, TO-220 package		P_D	-	11	W
ESD					
ESD tolerance (Note 2)			2000	-	V

■ RECOMMENDED OPERATING CONDITIONS

Parameter	Symbol	Min	Typ	Max	Unit
Supply voltage	V_{CC}	4.75	-	40	V
Output current TO-220	I_{OUT}	-	-	2000	mA
Operating junction temperature	T_j	-40	-	+100	°C
Error output current	I_{Err}	-	5	8	mA

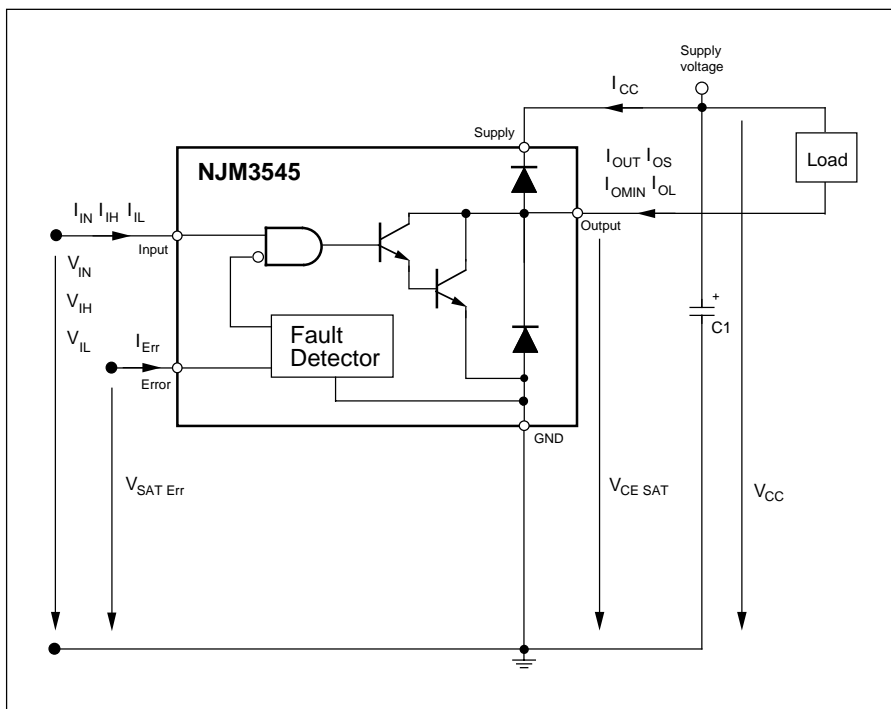

Figure 9. Definition of symbols

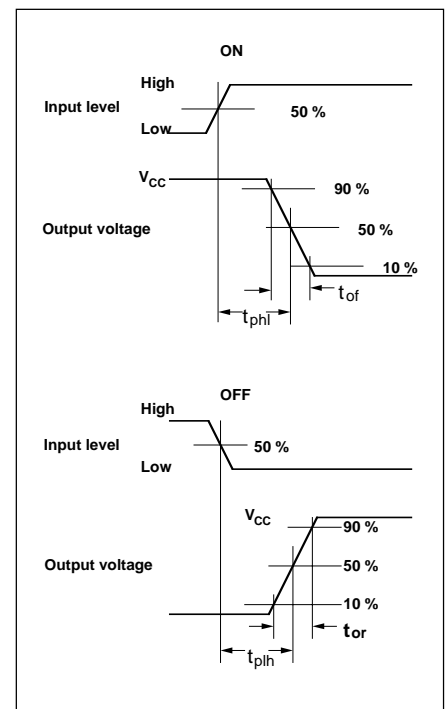

Figure 10. Timing diagram, input vs. output. $V_{CC} = 24\text{V}$

■ ELECTRICAL CHARACTERISTICS

 At $5\text{ V} \leq V_{CC} \leq 40\text{ V}$, $-40^\circ\text{C} \leq T_J \leq +100^\circ\text{C}$. Typical values are given at $V_{CC} = 24\text{ V}$, $T_J = 25^\circ\text{C}$

Parameter	Symbol	Conditions	Min	Typ	Max	Uni
General						
Supply current	I_{CC}	$0 \leq V_{IN} \leq 0.8$	1.5	4	7	mA
Thermal shutdown	T_{JS}		-	+130	-	$^\circ\text{C}$
Logic input						
High level input voltage	V_{IH}		2.0	-	V_{CC}	V
Low level input voltage	V_{IL}		-0.3	-	0.8	V
High level input current	I_{IH}	$2.0 \leq V_{IN} \leq V_{CC}$	-	9	20	μA
Low level input current	I_{IH}	$0 \leq V_{IN} \leq 0.8$	-400	-	-	μA
Outputs						
Error output saturation voltage	$V_{Err SAT}$	$I_{Err} = 5\text{ mA}$	-	0.2	1	V
Output saturation voltage	$V_{CE SAT}$	$I_{OUT} = 2\text{ A}$	-	1.4	1.8	V
Output current shutdown	I_{OS}	$2.0 \leq V_{IN} \leq V_{CC}$	2.0	3.2	4.5	A
Output current (not detected as open circuit)	I_{OMIN}	$2.0 \leq V_{IN} \leq V_{CC}$	0.5	2	8	mA
Output leakage current	I_{OL}	$0\text{ V} \leq V_{IN} \leq 0.8\text{ V}$. Output = 0 V	-8	-6	-2	μA
Clamping diode forward voltage		$I_F = 2.0\text{ A}$	-	1.5	1.8	V
Timing						
Propagation time		$I_{OUT} = 2\text{ A}$				
Output high to low (50%),	t_{phl}		-	1.5	3.0	μs
Output low to high (50%),	t_{plh}		-	0.5	1.0	μs
Rise time (10 to 90%),	t_{or}		-	0.2	0.5	μs
Fall time (90 to 10%),	t_{of}		-	0.2	0.5	μs

■ THERMAL CHARACTERISTICS

Parameter	Symbol	Conditions	Min	Typ	Max	Unit
Thermal resistance	$R_{th\ j-c}$	TO-220 package, junction to case	-	5	-	$^\circ\text{C/W}$
	$R_{th\ j-a}$	TO-220 package, junction to ambient	-	60	-	$^\circ\text{C/W}$

Notes:

1. Currents are defined positive if flowing into, and negative if flowing out of a terminal. Voltages are defined between terminal and ground.
2. ESD testing according to Human Body Model ($C_{Zap} = 100\text{ pF}$, $R_{Zap} = 1500\ \Omega$)

■ APPLICATIONS INFORMATION

Important application areas are:

- Programmable logic control systems
- Relay control
- Hydraulic valves
- Intelligent interfaces between microprocessors and loads
- Robot techniques
- Print head drivers
- High-current stepper motor drivers

Transient protection

1. Keep V_{CC} and GND leads as short as possible.
2. Connect a filter capacitor close to the circuit. Recommended filter capacitor between V_{CC} and GND is 6.8 μF , of tantalum type. A ceramic capacitor in parallel will improve high frequency decoupling. Typical values range from 0.002 μF to 0.1 μF . In an application having a highly stable supply and short power leads to the driver a low leakage electrolytic type can be used, which is less expensive.
3. Connect Input and Error via pull-up resistors to the appropriate logic supply level or V_{CC} to obtain highest noise immunity. See figure 11. The resistor R_1 limits the current into the Error indicating pin. This current must not exceed 8 mA. R_2 is a pull-up resistor which improves noise immunity at the Input. Pull-up current should not exceed the sinking capacity of the controlling device output.
4. If several supply voltages are to be used, prefer a supply having separate ground leads. In this case the logic ground and the power ground should be connected together at only one point, the ground pin of the driver.

Switch mode applications

The internal diodes are normally sufficient for clamping of transients caused by inductive load turn off. External diodes may be necessary in PWM/switch mode applications, and when the terminals are externally accessible and thereby exposed to an electrically noisy environment. Recommended diodes are BYV27/100, BYV98/100, UF4001 or similar types with a $t_{rr} < 100 \text{ ns}$ and $I_F \geq 1 \text{ A}$.

Error indication signal

When the circuit is switched on/off, a short pulse ($t_{Err} < 10 \mu\text{s}$ for resistive loads) is generated at the Error output. This is a correct detection of an incorrect level during the rise and fall times of the output voltage. Consequently the Error output should not be detected when switching on and off. An alternative is to low-pass filter at the Error output at around 100 kHz.

Heat sinking

NJM3545N is packaged in a 5-pin TO 220 power package. The circuit GND is connected to the heat sink tab. External heatsinking is achieved by mounting the package to a heat sink.

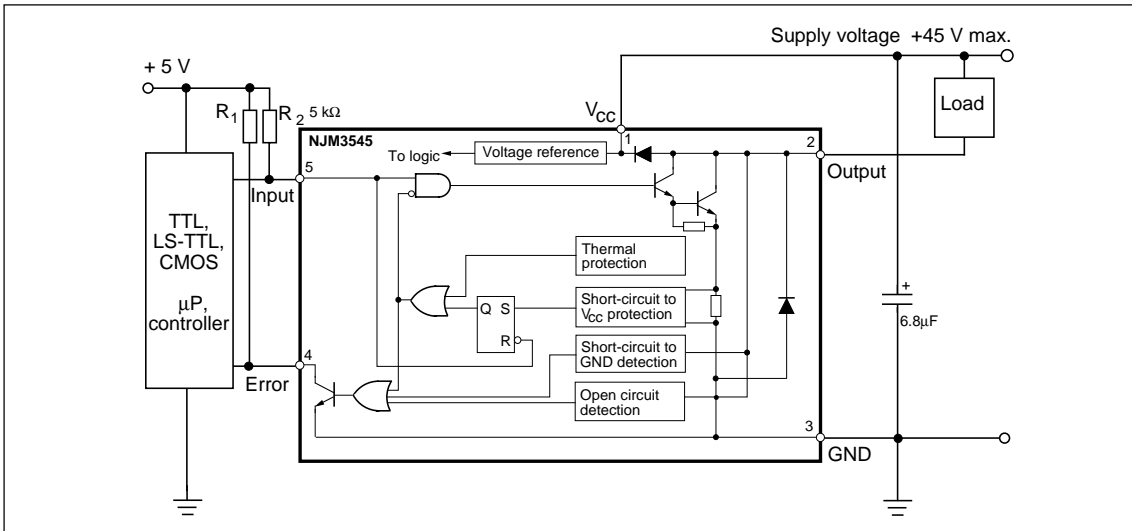

Figure 11. Typical application. Pin numbers refer to TO 220 package

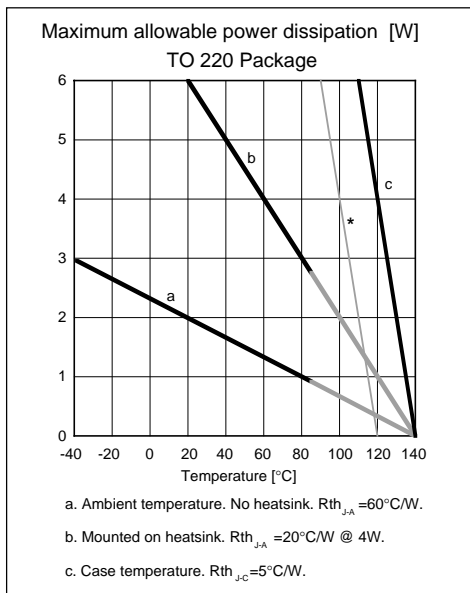

Figure 12. Maximum allowable power dissipation. TO 220 package

■ TYPICAL CHARACTERISTICS

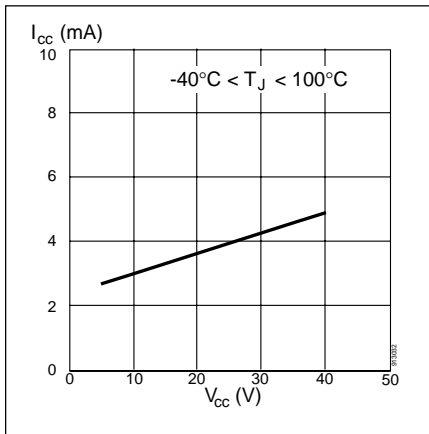

Figure 13. Current consumption vs. supply voltage at $0\text{ V} \leq V_{IN} \leq 0.8\text{ V}$ (Inactive output)

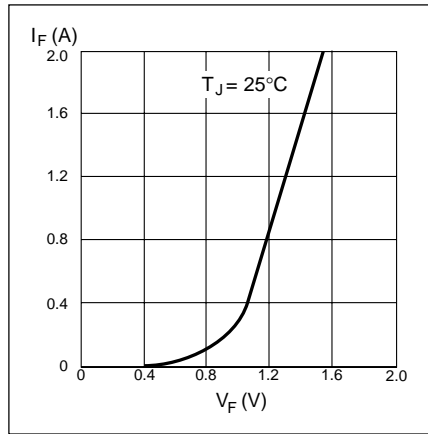

Figure 14. Diode forward voltage drop vs. forward current

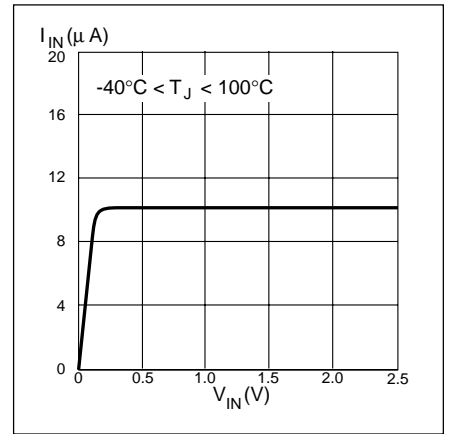

Figure 15. Input current vs. input voltage $5\text{ V} \leq V_{CC} \leq 40\text{ V}$

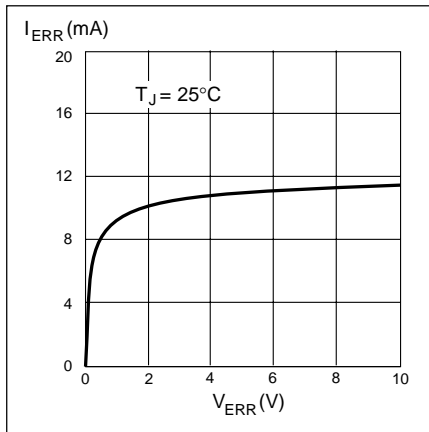

Figure 16. Error output saturation voltage vs. error current. $V_{CC} = 24\text{ V}$

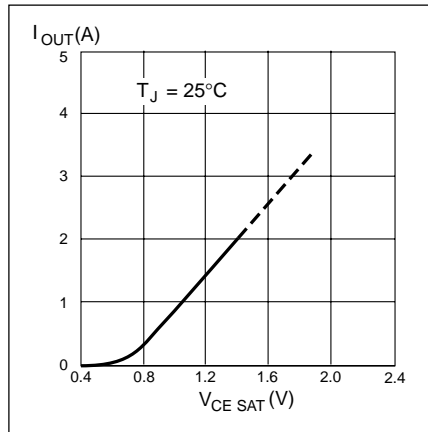

Figure 17. Output saturation voltage vs. output current. $5\text{ V} < V_{CC} < 40\text{ V}$

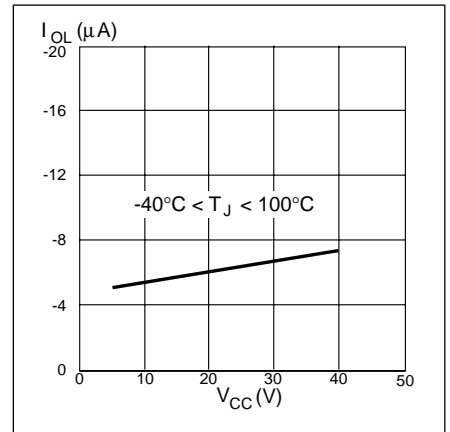

Figure 18. Output leakage current vs. supply voltage. $0\text{ V} \leq V_{IN} \leq 0.8\text{ V}$ Output = 0 V

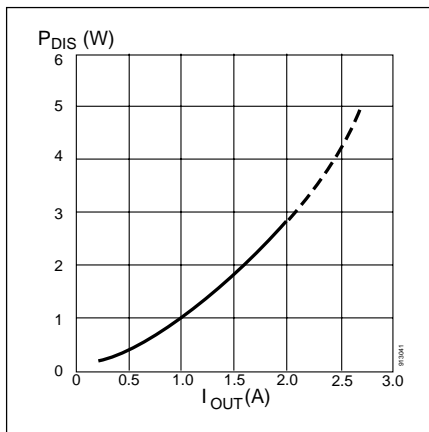

Figure 19. Power dissipation vs. output current

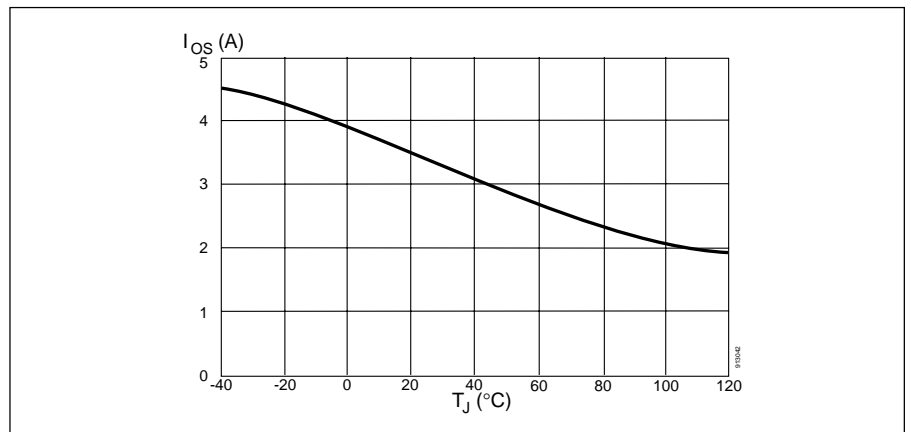

Figure 20. Typical output current shut-down vs. chip temperature. $5\text{ V} \leq V_{CC} \leq 40\text{ V}$

The specifications on this databook are only given for information, without any guarantee as regards either mistakes or omissions. The application circuits in this databook are described only to show representative usages of the product and not intended for the guarantee or permission of any right including the industrial rights.

Mouser Electronics

Authorized Distributor

Click to View Pricing, Inventory, Delivery & Lifecycle Information:

[NJR:](#)

[NJM3545TA2](#)