

AR8032 Integrated 10/100 Fast Ethernet Transceiver

General Description

The Atheros AR8032 Fast Ethernet transceiver is a highly integrated physical layer device that transmits and receives high-speed data over standard category 5 (CAT 5) unshielded twisted pair cable.

The AR8032 is compliant with 100 BASE-TX and 10 BASE-T IEEE 802.3 standards. The AR8032 device uses advanced mixed-signal processing technology and integrates functions such as adaptive equalization, and timing recovery to deliver substantial power savings and operation in noisy environments.

The AR8032 device supports the Media Independent Interface (MII) and Reduced Media Independent Interface (RMII) for direct connection to a Fast Ethernet-capable MAC.

The AR8032 supports the Atheros Cable Diagnostic Test (CDT) feature, which uses Time Domain Reflectometry (TDR) technology to quickly and remotely identify potential cable malfunctions without deploying field support personnel or bringing down the network. The AR8032 solution detects and reports issues such as PHY malfunctions, bad/marginal cable or patch cord segments or connectors, thus significantly reducing installation time, cable debug efforts, and overall network support cost.

Manufactured in a standard CMOS process, the AR8032 is packaged in a 32-pin QFN, featuring a small body size of 5 x 5mm.

Features

- 10/100 BASE-T IEEE 802.3 compliant
- Supports MII/RMII interface
- Low power modes with internal automatic DSP power saving scheme
- Fully integrated digital adaptive equalizers All digital baseline wander correction
- Supports external 25 MHz clock source in MII mode
- Supports external 50 MHz clock source in RMII mode
- Automatic speed downshift mode
- Automatic MDI/MDIX crossover
- Automatic polarity correction
- Loopback modes for diagnostics
- IEEE 802.3u compliant Auto-Negotiation
- Software programmable LED modes
- Cable Diagnostic Test (CDT)
- Requires only one 3.3V power supply
- 32-pin QFN 5mm x 5 mm package

AR8032 Functional Block Diagram

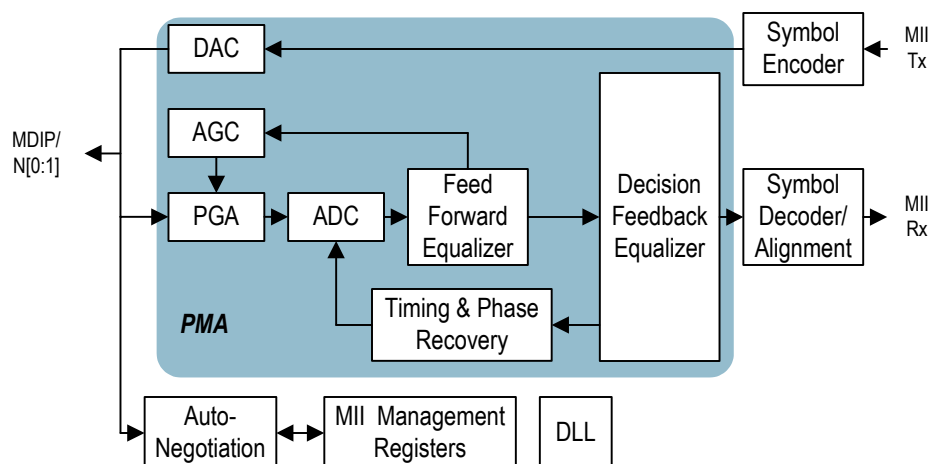

DO NOT COPY

Table of Contents

General Description.....	1		
Features	1		
AR8032 Functional Block Diagram	1		
1 Pin Descriptions	5		
2 Functional Description	9		
2.1 Transmit Functions	9		
2.2 Receive Functions.....	9		
2.2.1 Decoder Modes	9		
2.2.2 Analog to Digital Converter .	10		
2.2.3 Baseline Wander Cancellor ...	10		
2.2.4 Digital Adaptive Equalizer ...	10		
2.2.5 Auto-Negotiation.....	10		
2.2.6 Smartspeed Function	10		
2.2.7 Polarity Correction	10		
2.3 Loopback Modes	11		
2.3.1 Digital Loopback	11		
2.3.2 External Cable Loopback.....	11		
2.3.3 Cable Diagnostic Test.....	11		
2.3.4 LED Interface.....	11		
2.3.5 Power Supplies	11		
2.3.6 Low Power Modes.....	11		
2.3.7 Hibernation Mode	11		
3 Electrical Characteristics	13		
3.1 Absolute Maximum Ratings.....	13		
3.2 Recommended Operating Conditions	13		
3.3 XTAL/OSC Timing.....	14		
3.4 MII DC Characteristics	15		
3.5 MDIO Characteristics	16		
3.5.8 MDIO Timing.....	16		
3.6 Power-On Strapping.....	18		
3.7 Typical Power Consumption Parameters	18		
4 Register Descriptions.....	21		
4.1 PHY Register Summary	21		
4.1.1 Control Register.....	22		
4.1.2 Status Register.....	24		
4.1.3 PHY Identifier	26		
4.1.4 PHY Identifier 2	26		
4.1.5 Auto-Negotiation Advertisement Register	27		
4.1.6 Auto-Negotiation Expansion Register.....	29		
4.1.7 Link partner ability register(base		page).....	30
4.1.8 Function Control Register	31		
4.1.9 PHY Specific Status Register	33		
4.1.10 Interrupt Enable Register	34		
4.1.11 Interrupt Status Register	36		
4.1.12 Smart Speed Register	38		
4.1.13 Receive Error Count Register	40		
4.1.14 Virtual Cable Tester Control		Register	40
4.1.15 LED Control Register.....	41		
4.1.16 Manual LED Override Register	42		
4.1.17 Virtual Cable Tester Status Register	43		
4.1.18 Debug Port (Address Offset Set) Register	43		
4.1.19 Debug Port 2 (R/W Port) Register	44		
4.2 Power Saving and Debug Register Summary	45		
4.2.20 10Base-T Test Configuration Register	45		
4.2.21 100Base-TX Test Configuration Register	46		
4.2.22 Hibernate Control Register ...	48		
4.2.23 Power Saving Control.....	49		
5 Package Dimensions.....	51		
6 Ordering Information.....	53		

DO NOT COPY

1. Pin Descriptions

This section contains a package pinout for the AR8032 QFN 32pin and a listing of the signal descriptions (see [Figure 1-1](#)).

The following nomenclature is used for signal names:

NC	No connection to the internal die is made from this pin
_L	At the end of the signal name, indicates active low signals
P	Power

The following nomenclature is used for signal types described in [Table 1-1](#):

D	Open drain
IA	Analog input
I	Digital input
IH	Digital input with hysteresis
I/O	Digital input/output
OA	Analog output
O	Digital output
PD	Internal pull-down for digital input
PU	Internal pull-up for digital input

DO NOT COPY

Figure 1-1 shows the pinout diagram for the AR8032.

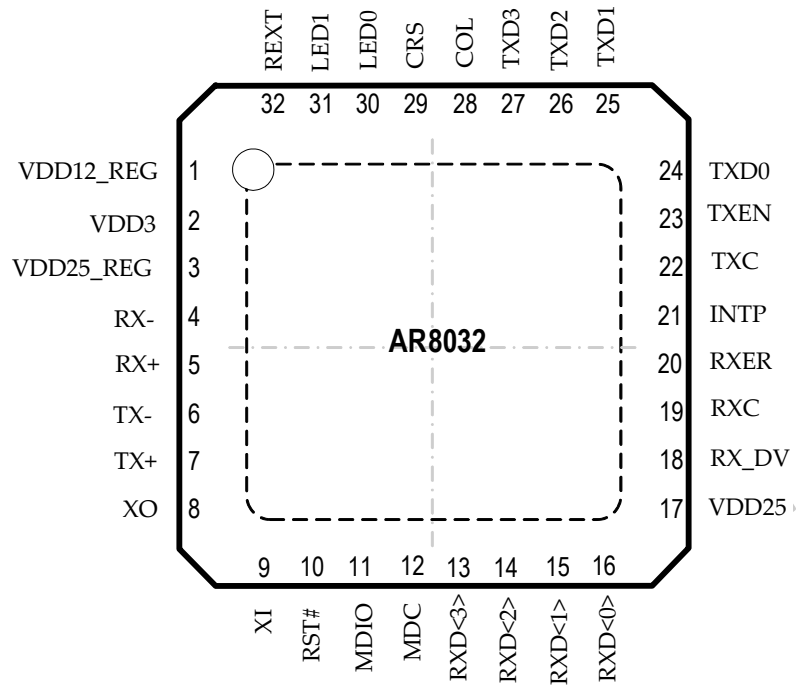

Figure 1-1. Pinout Diagram

NOTE: There is an exposed ground pad on the back side of the package.

Table 1-1. Signal to Pin Relationships and Descriptions

Symbol	Pin	Type	Description
VDD12_REG	1	AO	1.2V regulator output. A 1 uF plus a 0.1 uF cap needed to stabilize the output
VDD3	2	P	3.3V power supply.
VDD25_REG	3	AO	2.5V regulator output. A 1 uF ceramic cap needed to stabilize the output. It is for analog, digital I/O and the transformer center taps.
RX-	4	AI, AO	Media Dependent Interface 0, terminate with a 49.9Ω resistor and connect to XFMR
RX+	5	AI, AO	Media Dependent Interface 0, terminate with a 49.9Ω resistor and connect to XFMR
TX-	6	AI, AO	Media Dependent Interface 1, terminate with a 49.9Ω resistor and connect to XFMR
TX+	7	AI, AO	Media Dependent Interface 1, terminate with a 49.9Ω resistor and connect to XFMR
XO	8	AO	Crystal oscillator output. 27 pF to GND.
XI	9	AI	Crystal oscillator input. 27 pF to GND. An external 25/50 MHz clock source with swing from 0 to 1.2V can inject from this pin when a crystal is not used and the two 27pF caps removed. The 25 Mhz clock input is for MII mode, while the 50 Mhz clock input is for RMII mode.
RST#	10	IH, PU	System reset input.
MDIO	11	I/O, D, PU	Management data.
MDC	12	I, PU	Management clock reference.
RXD<3>	13	I/O, PU, POS	MII Receive data output [3].
RXD<2>	14	I/O, PD, POS	MII Receive data output [2].
RXD<1>	15	I/O, PD, POS	MII/RMII Receive data output [1].
RXD<0>	16	I/O, PU, POS	MII/RMII Receive data output [0].
VDD25	17	P	2.5V I/O power, connect with pin 3, 0.1uF to GND.
RX_DV	18	I/O, PD, POS	Receive data valid output
RXC	19	I/O, PD,	Receive clock output
RXER	20	I/O, PD	Receive error output
INTP	21	I/O, PU, POS	Interrupt Output
TXC	22	I/O, PU	Transmit clock output
TXEN	23	I, PU	Transmit data enable
TXD0	24	I, PD	MII/RMII Transmit data input [0]
TXD1	25	I, PD	MII/RMII Transmit data input [1]

Table 1-1. Signal to Pin Relationships and Descriptions (continued)

Symbol	Pin	Type	Description
TXD2	26	I, PD	MII Transmit data input [2]
TXD3	27	I, PD	MII Transmit data input [3]
COL	28	I/O, PD, POS	Collision Detect output
CRS	29	I/O, PD POS	Carrier Sense output
LED0	30	I/O, PU POS	Programable LED 0, the default indicates Link and Activity
LED1	31	I/O, PU POS	Programmable LED 1The default indicates Speed
REXT	32	AO	Connect 2.37 K to GND
PADDLE	GND	Gnd	Ground

NOTE: All of the digital input only pads are 3.3V input tolerant. The 0 and I/O pads are powered with 2.5V power. The input level of any I/O pads (except open-drain type) is limited to 2.5V.

2. Functional Description

The Atheros AR8032 is a highly integrated analog front end (AFE) and digital signal transceiver (see [Figure 2-1](#)), providing high performance with substantial cost reduction. AFE consists of automatic gain control (AGC), ADC, DAC, drivers, and clock generation. The AR8032 provides physical layer functions to

transmit and receive high-speed data over standard category 5 (CAT5) unshielded twisted pair cable.

See also the “[AR8032 Functional Block Diagram](#)” on [page 1](#).

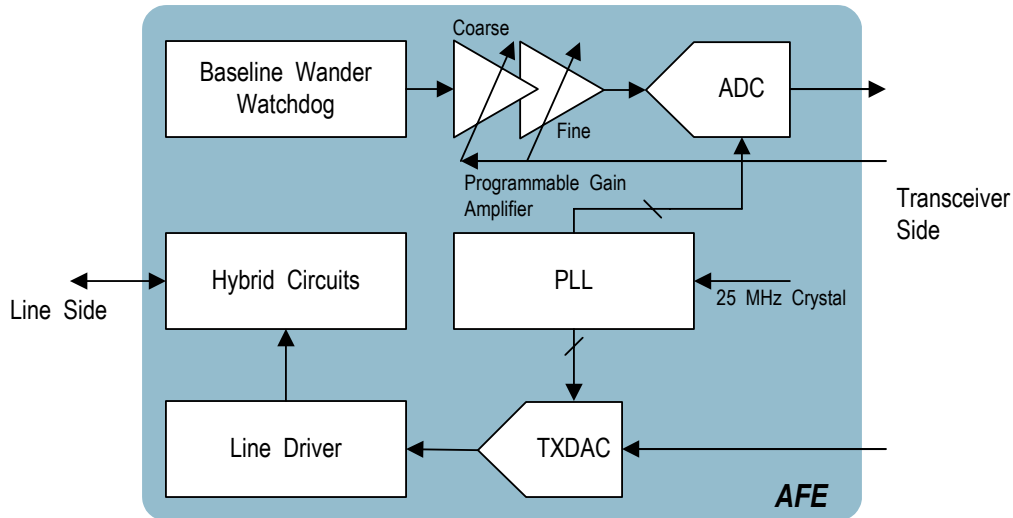

Figure 2-1. Analog Front End

The AR8032 10/100 PHY is fully 802.3, 802.3u compliant, and supports the media-independent interface (MII) and Reduced Media Independent Interface (RMII) to connect to a Fast Ethernet-capable MAC.

The AR8032 transceiver combines feed-forward equalizer, feedback equalizer, and timing recovery, to enhance signal performance in noisy environments.

2.1 Transmit Functions

The AR8032 transmit channel includes 4B/5B mapper and scrambler. [Table 2-1](#) describes the transmit function encoder modes.

Table 2-1. Transmit Function Encoder Modes

Encoder Mode	Description
100BASE-TX	In 100BASE-TX mode, 4-bit data from the MII is 4B/5B serialized, scrambled, and encoded to a three-level MLT3 sequence transmitted by the PMA.
10BASE-T	In 10BASE-T mode, the AR8032 transmits and receives Manchester-encoded data.

2.2 Receive Functions

The AR8032 receive channel includes digital gain control, feed forward adaptive equalizer, decision feedback equalizer, slicer, 5B/4B de-mapper and de-scrambler, PCS receive functional block, and timing recovery logic.

2.2.1 Decoder Modes

[Table 2-2](#) describes the receive function decoder modes.

Table 2-2. Receive Function Decoder Modes

Decoder Mode	Description
100BASE-TX	In 100BASE-TX mode, the receive data stream is recovered and descrambled to align to the symbol boundaries. The aligned data is then parallelized and 5B/4B decoded to 4-bit data. This output runs to the MII/RMII receive data pins after data stream delimiters have been translated.
10BASE-T	In 10BASE-T mode, the recovered 10BASE-T signal is decoded from Manchester then aligned.

2.2.2 Analog to Digital Converter

The AR8032 device employs an advanced high speed ADC on each receive channel with high resolution, which results in better SNR and lower error rates.

2.2.3 Baseline Wander Canceller

Baseline wander results from Ethernet links that AC-couple to the transceivers and from AC coupling that cannot maintain voltage levels for longer than a short time. As a result, transmitted pulses are distorted, resulting in erroneous sampled values for affected pulses. The AR8032 device uses an advanced baseline wander cancellation circuit that continuously monitors and compensates for this effect, minimizing the impact of DC baseline shift on the overall error rate.

2.2.4 Digital Adaptive Equalizer

The digital adaptive equalizer removes inter-symbol interference at the receiver. The digital adaptive equalizer takes unequalized signals from ADC output and uses a combination of feedforward equalizer (FFE) and decision feedback equalizer (DFE) for the best-optimized signal-to-noise (SNR) ratio.

2.2.5 Auto-Negotiation

The AR8032 device supports 10/100 BASE-T Copper auto-negotiation in accordance with IEEE 802.3 clauses 28 and 40. Auto-negotiation provides a mechanism for transferring information between a pair of link partners to choose the best possible mode of operation in terms of speed, duplex modes, and master/slave preference. Auto-negotiation is initiated upon any of the following scenarios:

- Power-up reset
- Hardware reset
- Software reset
- Auto-negotiation restart
- Transition from power-down to power-up
- The link goes down

If auto-negotiation is disabled, a 10BASE-T or 100BASE-TX can be manually selected using the IEEE MII registers.

2.2.6 Smartspeed Function

The Atheros Smartspeed function is an enhanced feature of auto-negotiation that allows the AR8032 device to fall back in speed based on cabling conditions as well as operate over CAT3 cabling (in 10BASE-T mode) or two-pair CAT5 cabling (in 100BASE-TX mode).

By default, the Smartspeed feature is enabled. Refer to the register “[Smart Speed Register](#)” on [page 38](#), which describes how to set the parameters. Set these register bits to control the Smartspeed feature:

- Bit [5]: 1 = Enables Smartspeed (default)
- Bits [4:2]: Sets the number of link attempts before adjusting
- Bit [1]: Timer to determine the stable link condition

2.2.7 Polarity Correction

If cabling has been incorrectly wired, the AR8032 automatically corrects polarity errors on the receive pairs.

2.3 Loopback Modes

2.3.1 Digital Loopback

Digital loopback provides the ability to loop transmitted data back to the receiver using digital circuitry in the AR8032 device. The registers “100Base-TX Test Configuration Register” on page 46 and “10Base-T Test Configuration Register” on page 45 are used to determine at which point the signal loops back (for different modes, respectively).

Figure 2-2 shows a block diagram of digital loopback.

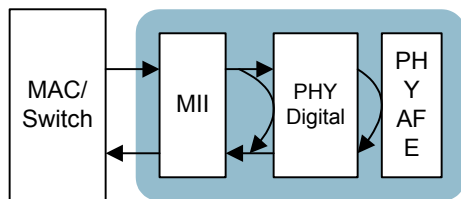

Figure 2-2. Digital Loopback

2.3.2 External Cable Loopback

External cable loopback loops MII Tx to MII Rx through a complete digital and analog path and an external cable, thus testing all the digital data paths and all the analog circuits. Figure 2-3 shows a block diagram of external cable loopback.

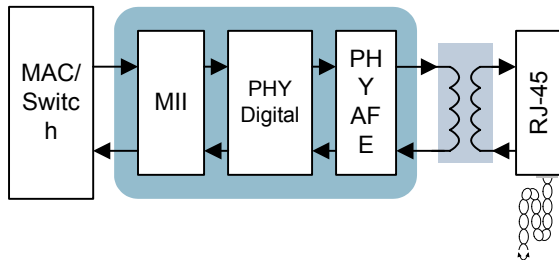

Figure 2-3. External Cable Loopback

2.3.3 Cable Diagnostic Test

The Cable Diagnostic Test (CDT) feature in the AR8032 device uses Time Domain Reflectometry (TDR) to identify remote and local PHY malfunctions, bad/marginal cable or patch cord segments, or connectors. Some of the possible problems that can be diagnosed include opens, shorts, cable impedance mismatch, bad connectors, termination mismatch, and bad magnetics. The CDT can be performed when there is no link partner or when the link partner is auto-negotiating.

2.3.4 LED Interface

The LED interface can either be controlled by the PHY or controlled manually, independent of the state of the PHY. Four status LEDs are available. These can be used to indicate operation speed, duplex mode, and link status. The LEDs can be programmed to different status functions from their default value. They can also be controlled directly from the MII register interface.

2.3.5 Power Supplies

The AR8032 device requires only one power supply: 3.3V.

2.3.6 Low Power Modes

The AR8032 device supports the software power-down low power mode. The standard IEEE power-down mode is entered by setting the POWER_DOWN bit (bit [11]) of the register “Control Register” on page 22 equal to one.

In this mode, the AR8032 device ignores all MAC interface signals except the MDC/MDIO. It does not respond to any activity on the CAT 5 cable. The device cannot wake up on its own. It can only wake up by setting the POWER_DOWN bit (bit [11]) of the register “Control Register” on page 22 to 0.

2.3.7 Hibernation Mode

The AR8032 device supports hibernation mode. When the cable is unplugged, the AR8032 will enter hibernation mode after about 10 seconds. The power consumption in this mode is very low compared to the normal mode of operation. When the cable is re-connected, the AR8032 wakes up and normal functioning is restored.

3. Electrical Characteristics

3.1 Absolute Maximum Ratings

Table 3-1 summarizes the absolute maximum ratings and Table 3-2 lists the recommended operating conditions for the AR8032. Absolute maximum ratings are those values beyond which damage to the device can occur. Functional operation under these conditions, or at any other condition beyond those indicated in the operational sections of this document, is not recommended.

Table 3-1. Absolute Maximum Ratings

Symbol	Parameter	Max Rating	Unit
VDD33	3.3V supply voltage	3.8	V
T _{store}	Storage temperature	-65 to 150	°C
ESD	Electrostatic discharge tolerance	2000	V

3.2 Recommended Operating Conditions

Table 3-2. Recommended Operating Conditions

Symbol	Parameter	Min	Typ	Max	Unit
VDD33	3.3V supply voltage	3.0	3.3	3.6	V
T _A	Ambient Temperature	0	—	70	°C
T _J	Junction Temperature	0	—	125	°C
Ψ _{JT}	Thermal Dissipation Coefficient	—	4	—	°C/W

NOTE: The following condition must be satisfied:

$$T_{Jmax} > T_{Cmax} + \Psi_{JT} \times P_{Typical}$$

Where:

T_{Jmax} = Maximum allowable temperature of the Junction

T_{Cmax} = Maximum allowable Case temperature

Ψ_{JT} = Thermal Dissipation Coefficient

P_{Typical} = Typical power dissipation

3.3 XTAL/OSC Timing

Figure 3-1 shows the XTAL timing diagram.

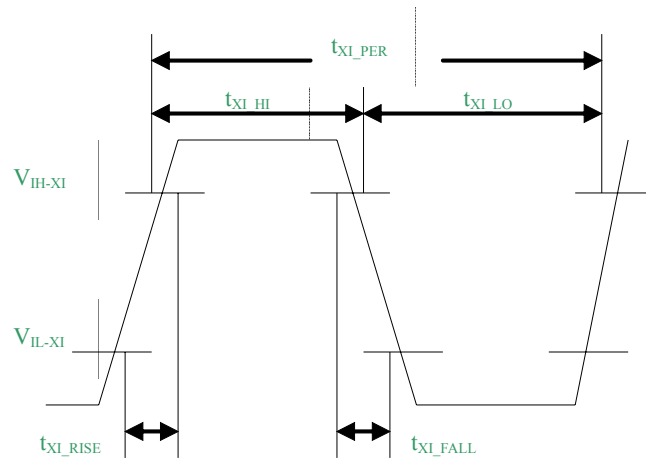

Figure 3-1. XTAL/OSC Timing Diagram

Table 3-3. XTAL/OSC Timing — MII mode

Symbol	Parameter	Min	Typ	Max	Unit
T_XI_PER	XI/OSCI Clock Period	40.0 - 50ppm	40.0	40.0 + 50ppm	ns
T_XI_HI	XI/OSCI Clock High	14	20.0		ns
T_XI_LO	XI/OSCI Clock Low	14	20.0		ns
T_XI_RISE	XI/OSCI Clock Rise Time, V_{IL} (max) to V_{IH} (min)			4	ns
T_XI_FALL	XI/OSCI Clock Fall time, V_{IL} (max) to V_{IH} (min)			4	ns
V_IH_XI	The XTLI input high level	0.8		1.4	V
V_IL_XI	The xtl input low lever voltage	-0.3		0.15	V

Table 3-4. XTAL/OSC Timing — RMII mode

Symbol	Parameter	Min	Typ	Max	Unit
T_XI_PER	XI/OSCI Clock Period	20.0 - 50ppm	20.0	20.0 + 50ppm	ns
T_XI_HI	XI/OSCI Clock High	8	10.0		ns
T_XI_LO	XI/OSCI Clock Low	8	10.0		ns
T_XI_RISE	XI/OSCI Clock Rise Time, V_{IL} (max) to V_{IH} (min)			2	ns

T_XI_FALL	XI/OSCI Clock Fall time, V_{IL} (max) to V_{IH} (min)			2	ns
V_IH_XI	The XTLI input high level	0.8		1.4	V
V_IL_XI	The xtli input low lever voltage	-0.3		0.15	V

3.4 MII DC Characteristics

Table 3-5 shows the MII DC characteristics.

Table 3-5. MII DC Characteristics

Symbol	Parameter	Min	Max	Unit
V_{OH}	Output high voltage	2.0	3.0	V
V_{OL}	Output low voltage	GND	0.4	V
V_{IH}	Input high voltage	1.7	—	V
V_{IL}	Input low voltage	—	0.7	V
I_{IH}	Input high current	—	15	μA
I_{IL}	Input low current	-15	—	μA

Figure 3-2 shows the MII input AC timing diagram.

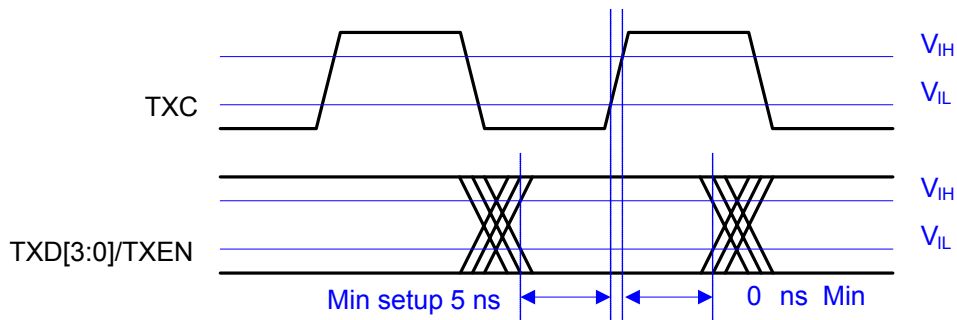

Figure 3-2. MII Input AC Timing Diagram

Figure 3-3 shows the MII output AC timing diagram.

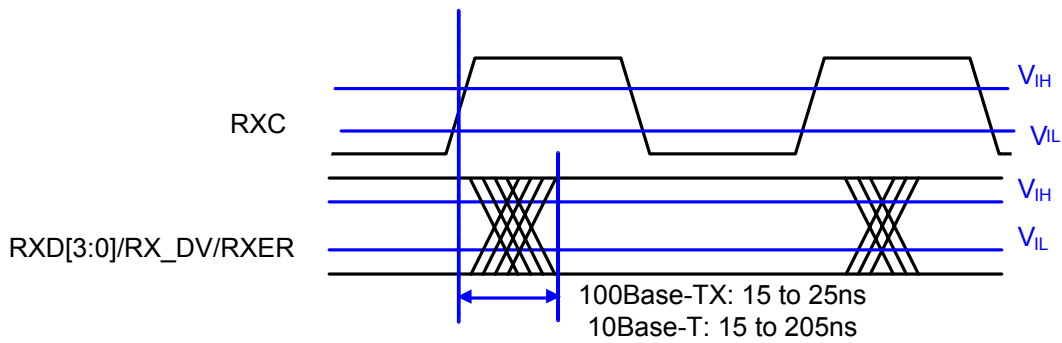

Figure 3-3. MII Output AC Timing Diagram

3.5 MDIO Characteristics

Table 3-6 shows the MDIO DC characteristics. RMII Timing

Table 3-6. MDIO DC Characteristics

Symbol	Parameter	Min	Max	Unit
V_{OH}	Output high voltage	2.4	—	V
V_{OL}	Output low voltage	—	0.4	V
I_{IH}	Input high current	—	-0.4	mA
I_{IL}	Input low current	0.4	—	mA

3.5.8 MDIO Timing

Figure 3-4 shows the MDIO timing diagram.

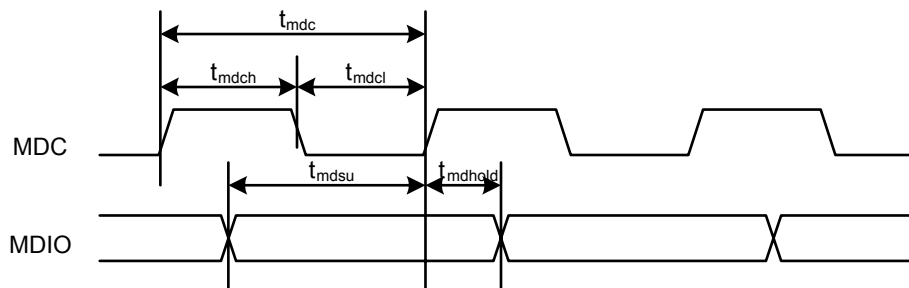

Figure 3-4. MDIO Timing Diagram

Table 3-7. MDIO Timing

Symbol	Parameter	Min	Typ	Max	Unit
tmdc	MDC Period	100			nS
tmdcl	MDC Low Period	40			nS
tmdch	MDC High Period	40			nS
tmdsu	MDIO to MDC rising setup time	10			nS
tmdhold	MDIO to MDC rising hold time	10			nS

Table 3-8 shows the RMII AC timing characteristics.

Table 3-8. RMII AC Timing

Symbol	Parameter	Min	Max	Unit
Tck	XI Period	—	20	nS
Tsu	TXEN, TXD to XI rising setup time	4	—	nS
Thold	TXEN, TXD to XI rising hold time	2	—	nS
Tdly	XI to RX_DV, RXD output delay	3	14	nS

Figure 3-5 shows the AC RMII timing diagram.

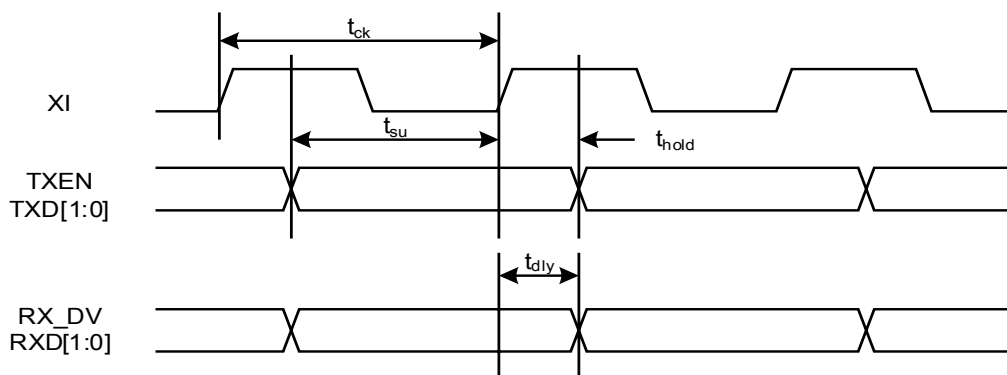

Figure 3-5. RMII AC Timing Diagram

3.6 Power-On Strapping

Table 3-9 shows the pin-to-PHY core configuration signal power-on strapping.

Table 3-9. Power-On Strapping^[1]

PHY Pin Name	Pin	PHY Core Configuration Signal	Description
RXD<3>	13	PHYADDRESS[0]	PHY address
RXD<2>	14	PHYADDRESS[1]	
RXD<1>	15	PHYADDRESS[2]	
RXD<0>	16	DUPLEX	1 = Full Duplex
RXDV	18	CONFIG2	CONFIG[2:0] 000 = MII 001 = RMII All other binary combinations are Reserved.
CRS	29	CONFIG1	
COL	28	CONFIG0	
TXC	22	EN_AB	Enable class AB mode
RXC	19	POWER_DOWN	Enable Power Down mode
RXER	20	ISOLATE	1 = enable 0 = disable
INTP	21	TESTMODE	1 = normal operation 0 = test mode
LED0	30	AUTO-NEGOTIATION	1 = enable 0 = disable
LED1	31	SPEED	1 = 100Mbps 0 = 10 Mbps

[1]Default values: 0 = Pull-down, 1 = Pull-up with 10 K resistor.

3.7 Typical Power Consumption Parameters

The following conditions apply to the typical characteristics unless otherwise specified:

$$V_{DD33} = 3.3V, T_{amb} = 25\text{ }^{\circ}\text{C}$$

Table 3-10 shows the typical power drain as a function of the AR8032's operating mode.

Table 3-10. Total System Power

Mode	Current (mA)	Power (mW)	Description
LDPS	3	9.9	Link down, power-saving mode
Isolate	18	59.4	Isolate mode
100F	92	303.6	100Base-T Full Duplex
10F	89	293.9	10Base-T Full Duplex
10TX	83	273.9	10Base-T Transmit

Table 3-10. Total System Power

Mode	Current (mA)	Power (mW)	Description
10RX	25	82.5	10Base-T Receive
10IDLE	21	69.3	10Base-T Idle

4. Register Descriptions

Table 4-1 shows the reset types used in this document.

Table 4-1. Reset Types

Type	Description
LH	Register field with latching high function. If status is high, then the register is set to one and remains set until a read operation is performed through the management interface or a reset occurs.
LL	Register field with latching low function. If status is low, then the register is cleared to a zero and remains cleared until a read operation is performed through the management interface or a reset occurs.
Retain	Value written to a register field takes effect without a software reset.
SC	Self-Clear. Writing a one to this register causes the desired function to execute immediately, and the register field clears to zero when the function is complete.
Update	The value written to the register field does not take effect until a software reset is executed. The value can still be read after it is written.
RES	Reserved for future use. All reserved bits are read as a zero unless otherwise noted.
RO	Read Only
ROC	Read Only Clear. After read, register field is cleared to zero.

Table 4-2. Register Summary

Offset	Register	Page
0x00	Control Register	page 22
0x01	Status	page 24
0x02	PHY Identifier	page 26
0x03	PHY Identifier 2	page 26
0x04	Auto-Negotiation Advertisement	page 29
0x05	Link Partner Ability	page 30
0x06	Auto-Negotiation Expansion	page 29
0x07	Reserved	
0x08	Reserved	
0x09	Reserved	
0x0A	Reserved	
0x0B	Reserved	

Table 4-1. Reset Types (continued)

Type	Description
R/W	Read/Write
RWC	Read/Write Clear. After read, register field is cleared to zero.
RWR	Read/Write Reset. All bits are readable and writable. After reset or read, the register field is cleared to zero.
RWS	Read/Write Set. All bits are readable and writable. After reset or read, the register field is set to a non-zero value specified in the text.
SC	Self-Clear. Writing a one to this register causes the desired function to be immediately executed, then the register field is cleared to zero when the function is complete.
WO	Write Only. Reads to this type of register return undefined data.

4.1 PHY Register Summary

Table 4-2 summarizes the registers for the AR8032.

Table 4-2. Register Summary (continued)

Offset	Register	Page
0x0C	Reserved	
0x0D	Reserved	
0x0E	Reserved	
0x0F	Reserved	
0x10	Function Control Register	page 22
0x11	PHY Specific Status Register	page 33
0x12	Interrupt Enable Register	page 34
0x13	Interrupt Status Register	page 36
0x14	Smart Speed Register	page 38
0x15	Recieve Error Counter Register	page 40
0x16	Virtual Cable Tester Control Register	page 40
0x18	Reserved	
0x19	LED Control Register	page 41
0x1A	Manual LED Override Register	page 42
0x1B	Reserved	
0x1C	Virtual Cable Tester Status Register	page 40
0x1D	Debug Port 1 (Address offset)	page 43
0x1E	Reserved	
0x1F	Reserved	

4.1.1 Control Register

Offset: 0x00

Mode: Read/Write

Hardware Reset: 0

Software Reset: See field descriptions

Bit	Name	Type		Description
15	Reset	Mode	R/W	PHY Software Reset. Writing a "1" to this bit causes the PHY the reset operation is done , this bit is cleared to "0" automatically. The reset occurs immediately. 1= PHY reset 0 =Normal operation
		HW Rst	0	
		SW Rst	SC	
14	Loopback	Mode	R/W	When loopback is activated, the transmitter data presented on TXD is looped back to RXD internally. Link is broken when loopback is enabled. 1 = Enable Loopback 0 = Disable Loopback
		HW Rst	0	
		SW Rst	0	

Bit	Name	Type		Description
13	Speed Selection (LSB)	Mode	R/W	Upon hardware reset , this bit and 0.6 bit depend upon anen(bit0.12) and SPEED: anen {0.6 , 0.13} 0 {0, SPEED} 1 2'b01 (00:10Mbps, 01:100Mbps, 10:Reserved, 11:Reserved)
		HW Rst	See Desc.	
		SW Rst	Retain	
12	Auto-negotiation	Mode	R/W	Upon hardware reset, this bit depends on ANEN_PAD. 1 = Enable Auto-Negotiation Process 0 = Disable Auto-Negotiation Process
		HW Rst	See Desc.	
		SW Rst	Retain	
11	Power Down	Mode	R/W	When the port is switched from power down to normal operation, software reset and restart Auto-Negotiation are performed even when bits Reset (0.15) and Restart Auto-Negotiation (0.9) are not set by the user. 1 = Power down 0 = Normal operation
		HW Rst	0	
		SW Rst	0	
10	Isolate	Mode	R/W	The MII output pins are tristated when this bit is set to 1. The MII inputs are ignored. 1 = Isolate 0 = Normal operation
		HW Rst	0	
		SW Rst	0	
9	Restart Auto-negotiation	Mode	R/W, SC	Auto-Negotiation automatically restarts after hardware or software reset regardless of whether or not the restart bit (0.9) is set. 1 = Restart Auto-Negotiation Process 0 = Normal operation
		HW Rst	0	
		SW Rst	SC	
8	Duplex mode	Mode	R/W, SC	Upon hardware reset, this bit bit depends on DUPLEX_MODE_PAD and anen bit(0.12): 0.12 0.8 0 0 1 DUPLEX_MODE_PAD 1:Full Duplex 0:Half Duplex
		HW Rst	See Desc.	
		SW Rst		
7	Collision Test	Mode	R/W	Setting this bit to 1 will cause the COL pin to assert whenever the TX_EN pin is asserted. 1 = Enable COL signal test 0 = Disable COL signal test
		HW Rst	0	
		SW Rst	0	
6	Speed Selection (MSB)	Mode	R/W	See bit 0.13.
		HW Rst	See Desc.	
		SW Rst		

Bit	Name	Type		Description
5:0	RES	Mode	RO	Reserved for future use.
		HW Rst	00000	
		SW Rst	00000	

4.1.2 Status Register

Offset: 0x01

Mode: Read/Write

Hardware Reset: 0

Software Reset: See field descriptions

Bit	Name	Type		Description
15	100Base-T4	Mode	RO	100BASE-T4. This protocol is not available. 0 = PHY not able to perform 100BASE-T4
		HW Rst	0	
		SW Rst	0	
14	100Base-Tx Full-Duplex	Mode	RO	Capable of 100Base-Tx Full-Duplex operation
		HW Rst	1	
		SW Rst	1	
13	100Base-Tx Half-Duplex	Mode	RO	Capable of 100Base-Tx Half-Duplex operation
		HW Rst	1	
		SW Rst	1	
12	10 Mbps Full-Duplex	Mode	RO	Capable of 10Base-T Full-Duplex operation
		HW Rst	1	
		SW Rst	1	
11	10 Mbps Half-Duplex	Mode	R/W	Capable of 10 Mbps Half-Duplex operation
		HW Rst	1	
		SW Rst	1	
10	100Base-T2 Full-Duplex	Mode	RO	Not able to perform 100Base-T2 Full-Duplex operation
		HW Rst	0	
		SW Rst	0	

Bit	Name	Type		Description
9	100Base-T2 Half-Duplex	Mode	R/W	Not able to perform 100Base-T2 Half-Duplex operation
		HW Rst	0	
		SW Rst	0	
8	Extended Status	Mode	RO	Extended status information in register 15
		HW Rst	1	
		SW Rst	1	
7	RES	Mode	RO	Reserved
		HW Rst	0	
		SW Rst	0	
6	MF Preamble Suppression	Mode	RO	PHY accepts management frames with preamble suppressed
		HW Rst	1	
		SW Rst	1	
5	Auto-negotiation Complete	Mode	RO	1: Auto negotiation process complete 0:Auto negotiation process not complete
		HW Rst	0	
		SW Rst	0	
4	Remote Fault	Mode	RO, LH	1: Remote fault condition detected 0:Remote fault condition not detected
		HW Rst	0	
		SW Rst	0	
3	Auto-Negotiation Ability	Mode	R/W	1: PHY able to perform auto-negotiation
		HW Rst	1	
		SW Rst	1	
2	Link Status	Mode	RO, LL	This register bit indicates whether the link was lost since the last read. For the current link status, read register bit 17.10 Link Real Time. 1 = Link is up 0 = Link is down
		HW Rst	0	
		SW Rst	0	

Bit	Name	Type		Description
1	Jabber Detect	Mode	RO, LH	1: Jabber condition detected 0: Jabber condition not detected
		HW Rst	0	
		SW Rst	0	
0	Extended Capability	Mode	RO	1: Extended register capabilities
		HW Rst	1	
		SW Rst	1	

4.1.3 PHY Identifier

Offset: 0x02

Bit	Name	Type		Description
15:0	Organizationally Unique Identifier Bits 3:18	Mode	RO	Organizationally Unique Identifier Bits 3:18
		HW Rst	Always 16'h 004d	
		SW Rst	Always 16'h 004d	

4.1.4 PHY Identifier 2

Offset: 0x03

Bit	Name	Type		Description
15:0	OUI bit 19:24 Model Number Revision Number	Mode	RO	Organizationally Unique Identifier Bits 3:18
		HW Rst	Always 16'h d023	
		SW Rst	Always 16'h d023	

4.1.5 Auto-Negotiation Advertisement Register

Offset: 0x04

Bit	Name	Type		Description
15	Next Page	Mode	R/W	<p>The value of this bit will be updated immediately after writing this register. But the value written to this bit does not takes effect until any one of the following occurs:</p> <ul style="list-style-type: none"> o Software reset is asserted (register 0.15) o Restart Auto-Negotiation is asserted (register 0.9) o Power down (register 0.11) transitions from power down to normal operation o Link goes down <p>If 1000BASE-T is advertised then the required next pages are automatically transmitted. Register 4.15 should be set to 0 if no additional next pages are needed.</p> <p>1 = Advertise 0 = Not advertised</p>
		HW Rst	0	
		SW Rst	Update	
14	Ack	Mode	RO	Must be 0
		HW Rst	Always 0	
		SW Rst	Always 0	
13	Remote Fault	Mode	R/W	<p>1 = Set Remote Fault bit 0 = Do not set Remote Fault bit</p>
		HW Rst	See Desc.	
		SW Rst	Update	
12	Reserved	Mode	RO	Always 0.
		HW Rst	Always 0	
		SW Rst	Always 0	
11	Asymmetric Pause	Mode	R/W	<p>Upon hardware reset , this bit depends on ASYM_PAUSE_PAD. The value of this bit will be updated immediately after writing this register. But the value written to this bit does not takes effect until any one of the following occurs:</p> <ul style="list-style-type: none"> o Software reset is asserted (register 0.15) o Restart Auto-Negotiation is asserted (register 0.9) o Power down (register 0.11) transitions from power down to normal operation o Link goes down <p>1 = Asymmetric Pause 0 = No asymmetric Pause</p>
		HW Rst	See Desc.	
		SW Rst	Update	

Bit	Name	Type		Description
10	PAUSE	Mode	R/W	Upon hardware reset , this bit depends on PAUSE_PAD. The value of this bit will be updated immediately after writing this register. But the value written to this bit does not takes effect until any one of the following occurs: o Software reset is asserted (register 0.15) o Restart Auto-Negotiation is asserted (register 0.9) o Power down (register 0.11) transitions from power down to normal operation o Link goes down 1 = MAC PAUSE implemented 0 = MAC PAUSE not implemented
		HW Rst	See Desc.	
		SW Rst	Update	
9	100BASE-T4	Mode	RO	Not able to perform 100BASE-T4
		HW Rst	Always 0	
		SW Rst	Always 0	
8	100BASE-TX Full Duplex	Mode	R/W	The value of this bit will be updated immediately after writing this register. But the value written to this bit does not takes effect until any one of the following occurs: o Software reset is asserted (register 0.15) o Restart Auto-Negotiation is asserted (register 0.9) o Power down (register 0.11) transitions from power down to normal operation o Link goes down 1 = Advertise 0 = Not advertised
		HW Rst	1	
		SW Rst	Update	
7	100BASE-TX Half Duplex	Mode	R/W	The value of this bit will be updated immediately after writing this register. But the value written to this bit does not takes effect until any one of the following occurs: o Software reset is asserted (register 0.15) o Restart Auto-Negotiation is asserted (register 0.9) o Power down (register 0.11) transitions from power down to normal operation o Link goes down 1 = Advertise 0 = Not advertised
		HW Rst	1	
		SW Rst	Update	
6	10BASE-TX Full Duplex	Mode	R/W	The value of this bit will be updated immediately after writing this register. But the value written to this bit does not takes effect until any one of the following occurs: o Software reset is asserted (register 0.15) o Restart Auto-Negotiation is asserted (register 0.9) o Power down (register 0.11) transitions from power down to normal operation o Link goes down 1 = Advertise 0 = Not advertised
		HW Rst	1	
		SW Rst	Update	

Bit	Name	Type		Description
5	10BASE-TX Half Duplex	Mode	R/W	The value of this bit will be updated immediately after writing this register. But the value written to this bit does not takes effect until any one of the following occurs: o Software reset is asserted (register 0.15) o Restart Auto-Negotiation is asserted (register 0.9) o Power down (register 0.11) transitions from power down to normal operation o Link goes down 1 = Advertise 0 = Not advertised
		HW Rst	1	
		SW Rst	Update	
4:0	Selector field	Mode	RO	Selector Field mode 00001 = 802.3
		HW Rst	Always 00001	
		SW Rst	Always 00001	

4.1.6 Auto-Negotiation Expansion Register

Offset: 0x06

Bit	Name	Type		Description
15:5	RES	Mode	RO	Reserved. Must be 0.
		HW Rst	Always 0	
		SW Rst	Always 0	
4	Parallel Detection Fault	Mode	RO, LH	1: a fault has been detect 0: no fault has been detected
		HW Rst	0	
		SW Rst	0	
3	Link Partner Next Page Able	Mode	RO	1: Link partner is Next page able 0: Link partner is not next page able
		HW Rst	0	
		SW Rst	0	
2	Local Next Page Able	Mode	RO	1 = Local Device is Next Page able
		HW Rst	1	
		SW Rst	1	

Bit	Name	Type		Description
1	Page Received	Mode	RO, LH	1: A new page has been received 0: No new page has been received
		HW Rst	0	
		SW Rst	0	
0	Link Partner Auto-Negotiation Able	Mode	RO	1: Link partner is auto negotiation able 0: Link partner is not auto negotiation able
		HW Rst	0	
		SW Rst	0	

4.1.7 Link partner ability register(base page)

Offset: 0x05

Bit	Name	Type		Description
15	Next page	Mode	RO	Received Code Word Bit 15 1 = Link partner capable of next page 0 = Link partner not capable of next page
		HW Rst	0	
		SW Rst	0	
14	Ack	Mode	RO	Acknowledge Received Code Word Bit 14 1 = Link partner received link code word 0 = Link partner does not have Next Page ability
		HW Rst	0	
		SW Rst	0	
13	Remote Fault	Mode	RO	Remote Fault Received Code Word Bit 13 1 = Link partner detected remote fault 0 = Link partner has not detected remote fault
		HW Rst	0	
		SW Rst	0	
12	Reserved	Mode	RO	Technology Ability Field Received Code Word Bit 12
		HW Rst	0	
		SW Rst	0	
11	Asymmetric Pause	Mode	RO	Technology Ability Field Received Code Word Bit 11 1 = Link partner requests asymmetric pause 0 = Link partner does not request asymmetric pause
		HW Rst	0	
		SW Rst	0	

Bit	Name	Type		Description
10	PAUSE	Mode	RO	Technology Ability Field Received Code Word Bit 10 1 = Link partner is capable of pause operation 0 = Link partner is not capable of pause operation
		HW Rst	0	
		SW Rst	0	
9	100BASE-T4	Mode	RO	Technology Ability Field Received Code Word Bit 9 1 = Link partner is 100BASE-T4 capable 0 = Link partner is not 100BASE-T4 capable
		HW Rst	0	
		SW Rst	0	
8	100BASE-TX Full Duplex	Mode	RO	Technology Ability Field Received Code Word Bit 8 1 = Link partner is 100BASE-TX full-duplex capable 0 = Link partner is not 100BASE-TX full-duplex capable
		HW Rst	0	
		SW Rst	0	
7	100BASE-TX Half Duplex	Mode	RO	Technology Ability Field Received Code Word Bit 7 1 = Link partner is 100BASE-TX half-duplex capable 0 = Link partner is not 100BASE-TX half-duplex capable
		HW Rst	0	
		SW Rst	0	
6	10BASE-TX Full Duplex	Mode	RO	Technology Ability Field Received Code Word Bit 6 1 = Link partner is 10BASE-T full-duplex capable 0 = Link partner is not 10BASE-T full-duplex capable
		HW Rst	0	
		SW Rst	0	
5	10BASE-TX Half Duplex	Mode	RO	Technology Ability Field Received Code Word Bit 5 1 = Link partner is 10BASE-T half-duplex capable 0 = Link partner is not 10BASE-T half-duplex capable
		HW Rst	0	
		SW Rst	0	
4:0	Selector field	Mode	RO, LH	Selector Field Received Code Word Bit 4:0
		HW Rst	0	
		SW Rst	0	

4.1.8 Function Control Register

Offset: 0x10

Bit	Name	Type		Description
15:12	RES	Mode	R/W	Reserved
		HW Rst	0	
		SW Rst	Retain	
11	Assert CRS on Transmit	Mode	R/W	1 = when transmitting, crs_o is asserted to 1; 0 = crs_o is asserted to 1 only when receiving. When in RMII mode, this bit is fixed to 0.
		HW Rst	1	
		SW Rst	Retain	
10	RES	Mode	R/W	Reserved
		HW Rst	0	
		SW Rst	Retain	
9:7	RES	Mode	R/W	Reserved
		HW Rst	0	
		SW Rst	Retain	
6:5	MDI Crossover Mode	Mode	R/W	Changes to these bits are disruptive to the normal operation; therefore any changes to these registers must be followed by a software reset to take effect. 00 = Manual MDI configuration 01 = Manual MDIX configuration 10 = Reserved 11 = Enable automatic crossover for all modes
		HW Rst	11	
		SW Rst	Update	
4:3	RES	Mode	R/W	Reserved
		HW Rst	0	
		SW Rst	Retain	
2	SQE Test	Mode	R/W	SQE Test is automatically disabled in full-duplex mode 1 = SQE test enabled 0 = SQE test disabled
		HW Rst	0	
		SW Rst	Retain	
1	RES	Mode	R/W	Reserved
		HW Rst	0	
		SW Rst	Retain	

Bit	Name	Type		Description
0	Disable Jabber	Mode	R/W	Jabber has effect only in 10BASE-T half-duplex mode. 1 = Disable jabber function 0 = Enable jabber function
		HW Rst	0	
		SW Rst	Retain	

4.1.9 PHY Specific Status Register

Offset: 0x11

Bit	Name	Type		Description
15:14	Speed	Mode	RO	These status bits are valid only after resolved bit 17.11 = 1. The resolved bit is set when Auto-Negotiation is completed or Auto-Negotiation is disabled. 11 = Reserved 10 = Reserved 01 = 100 Mbps 00 = 10 Mbps
		HW Rst	00	
		SW Rst	Retain	
13	Duplex	Mode	RO	This status bit is valid only after resolved bit 17.11 = 1. The resolved bit is set when Auto-Negotiation is completed or Auto-Negotiation is disabled. 1 = Full-duplex 0 = Half-duplex
		HW Rst		
		SW Rst		
12	Page Received (real-time)	Mode	RO	1 = Page received 0 = Page not received
		HW Rst	0	
		SW Rst	Retain	
11	Speed and Duplex Resolved	Mode	RO	When Auto-Negotiation is not enabled, 17.11 = 1 for force speed mode. 1 = Resolved 0 = Not resolved
		HW Rst	0	
		SW Rst	0	
10	Link (real-time)	Mode	RO	1 = Link up 0 = Link down
		HW Rst	0	
		SW Rst	0	
9:7	RES	Mode	RO	Reserved
		HW Rst	Always 0	
		SW Rst	Always 0	

Bit	Name	Type		Description
6	MDI Crossover Status	Mode	RO	This status bit is valid only after resolved bit 17.11 = 1. The resolved bit is set when Auto-Negotiation is completed or Auto-Negotiation is disabled. This bit is 0 or 1 depending on what is written to 16.6:5 in manual configuration mode. Register 16.6:5 are updated with software reset. 1 = MDIX 0 = MDI
		HW Rst	0	
		SW Rst	Retain	
5	Wirespeed Downgrade	Mode	RO	1 = Downgrade 0 = No Downgrade
		HW Rst	0	
		SW Rst	0	
4	RES	Mode	RO	Reserved
		HW Rst	0	
		SW Rst	0	
3	Transmit Pause Enabled	Mode	RO	This is a reflection of the MAC pause resolution. This bit is for information purposes and is not used by the device. This status bit is valid only after resolved bit 17.11 = 1. The resolved bit is set when Auto-Negotiation is completed; While in force mode, this bit is set to be 0. 1 = Transmit pause enabled 0 = Transmit pause disabled
		HW Rst		
		SW Rst		
2	Receive Pause Enabled	Mode	RO	This is a reflection of the MAC pause resolution. This bit is for information purposes and is not used by the device. This status bit is valid only after resolved bit 17.11 = 1. The resolved bit is set when Auto-Negotiation is completed; While in force mode, this bit is set to be 0. 1 = Receive pause enabled 0 = Receive pause disabled
		HW Rst		
		SW Rst		
1	Polarity (real-time)	Mode	RO	1 = Reversed 0 = Normal
		HW Rst	0	
		SW Rst	Retain	
0	Jabber (real-time)	Mode	RO	1 = Jabber 0 = No jabber
		HW Rst	0	
		SW Rst	Retain	

4.1.10 Interrupt Enable Register

Offset: 0x12

Bit	Name	Type		Description
15	Auto-Negotiation Error Interrupt Enable	Mode	R/W	1 = Interrupt enable 0 = Interrupt disable
		HW Rst	0	
		SW Rst	Retain	
14	Speed Changed Interrupt Enable	Mode	R/W	1 = Interrupt enable 0 = Interrupt disable
		HW Rst	0	
		SW Rst	Retain	
13	Duplex Changed Interrupt Enable	Mode	R/W	1 = Interrupt enable 0 = Interrupt disable
		HW Rst	0	
		SW Rst	Retain	
12	Page Received Interrupt Enable	Mode	R/W	1 = Interrupt enable 0 = Interrupt disable
		HW Rst	0	
		SW Rst	Retain	
11	Link Fail Interrupt Enable	Mode	R/W	1 = Interrupt enable 0 = Interrupt disable
		HW Rst	0	
		SW Rst	Retain	
10	Link Success Interrupt Enable	Mode	R/W	1 = Interrupt enable 0 = Interrupt disable
		HW Rst	0	
		SW Rst	Retain	
9	RES	Mode	R/W	Reserved
		HW Rst	0	
		SW Rst	Retain	
8	RES	Mode	R/W	Reserved
		HW Rst	0	
		SW Rst	0	

Bit	Name	Type		Description
7	RES	Mode	R/W	Reserved
		HW Rst	0	
		SW Rst	Retain	
6	MDI Crossover Changed Interrupt Enable	Mode	R/W	1 = Interrupt enable 0 = Interrupt disable
		HW Rst	0	
		SW Rst	Retain	
5	Wirespeed-downgrade Interrupt Enable	Mode	R/W	1 = Interrupt enable 0 = Interrupt disable
		HW Rst	0	
		SW Rst	Retain	
4:2	RES	Mode	R/W	Reserved
		HW Rst	000	
		SW Rst	Retain	
1	Polarity Changed Interrupt Enable	Mode	R/W	1 = Interrupt enable 0 = Interrupt disable
		HW Rst	0	
		SW Rst	Retain	
0	Jabber Interrupt Enable	Mode	R/W	1 = Interrupt enable 0 = Interrupt disable
		HW Rst		
		SW Rst		

4.1.11 Interrupt Status Register

Offset: 0x13

Bit	Name	Type		Description
15	Auto-Negotiation Error	Mode	RO, LH	An error is said to occur if MASTER/SLAVE does not resolve, parallel detect fault, no common HCD, or link does not come up after negotiation is completed. 1 = Auto-Negotiation Error 0 = No Auto-Negotiation Error
		HW Rst	0	
		SW Rst	Retain	

Bit	Name	Type		Description
14	Speed Changed	Mode	RO, LH	1 = Speed changed 0 = Speed not changed
		HW Rst	0	
		SW Rst	Retain	
13	Duplex Changed	Mode	RO, LH	1 = Duplex changed 0 = Duplex not changed
		HW Rst	0	
		SW Rst	Retain	
12	Page Received	Mode	RO, LH	1 = Page received 0 = Page not received
		HW Rst	0	
		SW Rst	Retain	
11	Link Fail Interrupt	Mode	RO, LH	1 = Link down happened. 0 = Link down not happened.
		HW Rst	0	
		SW Rst	Retain	
10	Link Success Interrupt	Mode	RO, LH	1 = Link down happened. 0 = Link down not happened.
		HW Rst	0	
		SW Rst	Retain	
9	RES	Mode	RO, LH	Reserved
		HW Rst	0	
		SW Rst	Retain	
8	RES	Mode	RO	Reserved
		HW Rst	0	
		SW Rst	0	
7	RES	Mode	RO	Reserved
		HW Rst	0	
		SW Rst	0	
6	MDI Crossover Changed	Mode	RO, LH	1 = Crossover changed 0 = Crossover not changed
		HW Rst	0	
		SW Rst	Retain	

Bit	Name	Type		Description
5	Wirespeed-downgrade Interrupt	Mode	RO, LH	1 = Wirespeed-downgrade detected. 0 = No Wirespeed-downgrade.
		HW Rst	0	
		SW Rst	Retain	
4:2	RES	Mode	RO	Reserved
		HW Rst	000	
		SW Rst	000	
1	Polarity Changed	Mode	RO, LH	1 = Polarity Changed 0 = Polarity not changed
		HW Rst	0	
		SW Rst	Retain	
0	Jabber	Mode	RO, LH	1 = Jabber 0 = No jabber
		HW Rst	0	
		SW Rst	Retain	

4.1.12 Smart Speed Register

Offset: 0x14

Bit	Name	Type		Description
15:11	RES	Mode	RO	Reserved. Must be 00000000.
		HW Rst	0	
		SW Rst	0	
10:9	Reserved	Mode	R/W	Reserved
		HW Rst	1'b0	
		SW Rst	Retain	
8	RES	Mode	RO	Reserved
		HW Rst	1'b0	
		SW Rst	Update	

Bit	Name	Type		Description
7:6	RES	Mode	R/W	Reserved
		HW Rst	0	
		SW Rst	Update	
5	Smartspeed_en	Mode	R/W	The default value is one; if this bit is set to one and cable inhibits completion of the training phase, then After a few failed attempts, the Atheros card automatically downgrades the highest ability to the next lower speed: from 100 to 10.
		HW Rst	0	
		SW Rst	Update	
4:2	Smartspeed_retry_limit	Mode	R/W	The default value is three; if these bits are set to three, then the Atheros card will attempt five times before downgrading; The number of attempts can be changed through setting these bits.
		HW Rst	0	
		SW Rst	Update	
1	Bypass_smartspeed_timer	Mode	R/W	The default value is zero; if this bit is set to one, the Smartspeed FSM will bypass the timer used for stability.
		HW Rst	0	
		SW Rst	Update	
0	RES	Mode	R/W	Reserved.
		HW Rst	0	
		SW Rst	0	

4.1.13 Receive Error Count Register

Offset: 0x15

Bit	Name	Type		Description
15:0	Receive Error Count	Mode	RO	Counter will peg at 0xFFFF and will not roll over. (when rx_dv is valid, count rx_er numbers) (in this version, only for 100Base-T)
		HW Rst	0	
		SW Rst	0	

4.1.14 Virtual Cable Tester Control Register

Offset: 0x16

Bit	Name	Type		Description
15:11	Vct_dbg_psw	Mode	RO	For VCT debug
		HW Rst	0	
		SW Rst	0	
10	vct_wp_Max_vcode[3]	Mode	RO	For VCT debug
		HW Rst	1'b1	
		SW Rst	Retain	
9:8	MDI Pair Select	Mode	R/W	Virtual Cable Tester™ Control registers. Use the Virtual Cable Tester Control Registers to select which MDI pair is shown in the Virtual Cable Tester Status register. 00 = MDI[0] pair 01 = MDI[1] pair 10 = Reserved 11 = Reserved
		HW Rst	00	
		SW Rst	00	
7:5	vct_wp_Max_vcode[2:0]	Mode	RO	For VCT debug
		HW Rst	3'b111	
		SW Rst	Retain	
4:1	vct_np_Max_vcode[3:0]	Mode	R/W	For VCT debug
		HW Rst	3'b111	
		SW Rst	Retain	

Bit	Name	Type		Description
0	Enable Test	Mode	R/W	When set, hardware automatically disable this bit when VCT is done. 1 = Enable VCT Test 0 = Disable VCT Test
		HW Rst	0	
		SW Rst	Retain	

4.1.15 LED Control Register

Offset: 0x18

Bit	Name	Type		Description
15	Disable LED	Mode	R/W	Control the output LED pins. 0 = Enable 1 = Disable
		HW Rst	0	
		SW Rst	Retain	
14:12	LED On Time	Mode	R/W	000 = 5 ms 001 = 10ms 010 = 21 ms 011 = 42ms 100 = 84 ms 101 = 168ms 110 to 111 = 42ms
		HW Rst	0	
		SW Rst	Retain	
11	Force Interrupt	Mode	RO	Always 0
		HW Rst	0	
		SW Rst	0	
10:8	LED Off Time	Mode	R/W	000 = 21 ms 001 = 42 ms 010 = 84 ms 011 =168 ms 100 =330 ms 101 = 670 ms 110 to 111 = 168ms
		HW Rst	0	
		SW Rst	0	
7:5	RES	Mode	RO	Reserved
		HW Rst	000	
		SW Rst	000	
4:3	LED_LINK Control	Mode	R/W	00 = Direct LED mode 11 = Master/Slave LED mode 01, 10 = Combined LED modes
		HW Rst	0	
		SW Rst	Retain	

Bit	Name	Type		Description
2	LED_DUPLEX Control	Mode	R/W	0 = Duplex 1 = Duplex/Collision
		HW Rst	0	
		SW Rst	Retain	
1	LED_RX Control	Mode	R/W	1 = Receive activity/Link 0 = Receive activity
		HW Rst	0	
		SW Rst	Retain	
0	LED_TX Control	Mode	R/W	1 = Activity/Link 0 = Transmit activity
		HW Rst	0	
		SW Rst	Retain	

4.1.16 Manual LED Override Register

Offset: 0x19

Bit	Name	Type		Description
15:12	RES	Mode	RO	Reserved
		HW Rst	0	
		SW Rst	0	
11:10	LED_DUPLEX	Mode	R/W	LED "Off" means LED pin output equals high. LED "On" means LED pin output equals low. 00 = Normal 01 = Blink 10 = LED Off 11 = LED On
		HW Rst	00	
		SW Rst	Retain	
9:8	LED_LINK10	Mode	RO	LED "Off" means LED pin output equals high. LED "On" means LED pin output equals low. 00 = Normal 01 = Blink 10 = LED Off 11 = LED On
		HW Rst	00	
		SW Rst	Retain	
7:6	LED_LINK100	Mode	R/W	LED "Off" means LED pin output equals high. LED "On" means LED pin output equals low. 00 = Normal 01 = Blink 10 = LED Off 11 = LED On
		HW Rst	00	
		SW Rst	Retain	

Bit	Name	Type		Description
5:4	RES	Mode	RO	Reserved
		HW Rst	0	
		SW Rst	Retain	
3:2	LED_RX	Mode	R/W	LED "Off" means LED pin output equals high. LED "On" means LED pin output equals low. 00 = Normal 01 = Blink 10 = LED Off 11 = LED On
		HW Rst	00	
		SW Rst	Retain	
1:0	LED_TX	Mode	R/W	LED "Off" means LED pin output equals high. LED "On" means LED pin output equals low. 00 = Normal 01 = Blink 10 = LED Off 11 = LED On
		HW Rst	00	
		SW Rst	Retain	

4.1.17 Virtual Cable Tester Status Register

Offset: 0x1C

Bit	Name	Type		Description
15:10	RES	Mode	RO	Reserved
		HW Rst	0	
		SW Rst	0	
9:8	Status	Mode	RO	The content of the Virtual Cable Tester Status Registers applies to the cable pair selected in the Virtual Cable Tester™ Control Registers. 11 = Link-up state, no short or open in cable 00 = Valid test, normal cable (no short or open in cable) 10 = Valid test, open in cable (Impedance > 333 ohms) 01 = Valid test, short in cable (Impedance < 33 ohms)
		HW Rst	00	
		SW Rst	00	
7:0	Delta_Time	Mode	R/W	Delta time indicates distance along the cable
		HW Rst	0	
		SW Rst	0	

4.1.18 Debug Port (Address Offset Set) Register

Offset: 0x1D

Bit	Name	Type		Description
15:6	RES	Mode	RO	Reserved
		HW Rst	0	
		SW Rst	0	
5:0	Addres Offset	Mode	R/W	The address index of the register will be written or read.
		HW Rst	0	
		SW Rst	0	

4.1.19 Debug Port 2 (R/W Port) Register

Offset: 0x1E

Bit	Name	Type		Description
15:0	Debug Data Port	Mode	R/W	The data port for the debug register. Before accessing this register, you must set the address offset first.
		HW Rst	0	
		SW Rst	0	

4.2 Power Saving and Debug Register Summary

Table 4-2 summarizes the registers for the AR8032.

Table 4-3. Register Summary

Offset	Register	Page
0x12	Test Configuration for 10Base-T	page 45
0x10	Test Configuration for 100Base-Tx	page 46
0x1B	Hibernate Control	page 48
0x29	Power Saving Control	page 49

4.2.20 10Base-T Test Configuration Register

Offset: 0x12

Bit	Name	Type	Description	
15:14	Interval_sel_timer	Mode	R/W	Controls the interval that PHY detects whether the data frames on the cable are MLT-3 coded. This logic is used to divide Manchester code from MLT-3 code.
		HW Rst	0	
		SW Rst	Retain	
13:12	Triger_sel_timer	Mode	R/W	Controls the threshold that PHY detects at the end of the interval whether the data frames on the cable are MLT-3 coded. This logic is used to divide Manchester code from MLT-3 code.
		HW Rst	00	
		SW Rst	Retain	
11	En_mask_bt	Mode	R/W	1: enable the function of dividing Manchester code from MLT-3 code. 0: disable the function.
		HW Rst	1	
		SW Rst	0	
10	En_10bt_idle	Mode	R/W	1: In 10BT mode , if there's no data or NLP to transmit, shut off dac; otherwise turn on the dac; 0: In 10BT, dac will not be turn off.
		HW Rst	0	
		SW Rst	0	
9:6	RES	Mode	RO	Reserved
		HW Rst	0	
		SW Rst	0	
5	Test_mode[2]	Mode	R/W	bit 2 of test_mode
		HW Rst	0	
		SW Rst	0	

Bit	Name	Type		Description
4	En_longcable	Mode	R/W	Enable long cable test
		HW Rst	0	
		SW Rst	Retain	
3	RES	Mode	R/W	Reserved
		HW Rst	0	
		SW Rst	Retain	
2	Loopback mode select	Mode	RO	1: lpbk2-deep in Loopback mode 0: lpbk1-shallow in Loopback mode (connect to dig10.test_mode_i[0])
		HW Rst	0	
		SW Rst	0	
1:0	Test_mode[1:0]	Mode	R/W	[001]: packet with all ones, 10MHz sine wave, For harmonic test. [010]: pseudo random, for TP_IDLE/Jitter/Differential Voltage test. [011]: normal link pulse only, [100]: 5MHz sin wave. Others: normal mode.
		HW Rst	0	
		SW Rst	0	

4.2.21 100Base-TX Test Configuration Register

Offset: 0x10

Bit	Name	Type		Description
15	TM100_ENA	Mode	R/W	Enable dig100 loopback test mode.
		HW Rst	0	
		SW Rst	Retain	
14:8	RES	Mode	R/W	Reserved
		HW Rst	0	
		SW Rst	Retain	
7	Jitter_test	Mode	R/W	100Base-Tx Jitter test
		HW Rst	0	
		SW Rst	Retain	

Bit	Name	Type		Description
6	Os_test	Mode	R/W	100Base-Tx Overshoot test
		HW Rst	0	
		SW Rst	Retain	
5	Dcd_test	Mode	R/W	100Base-Tx DCD test
		HW Rst	0	
		SW Rst	Retain	
4	PMD_LPBK_2	Mode	R/W	PMD loopback, test MLT-3 Encoder and Decoder
		HW Rst	0	
		SW Rst	0	
3	PMD_LPBK_1	Mode	R/W	PMD loopback, test Scrambler and Descrambler
		HW Rst	0	
		SW Rst	0	
2	PMA_LPBK_1	Mode	R/W	PMD loopback, test Carrier Detect and Link Monitor
		HW Rst	0	
		SW Rst	0	
1	PMA_LPBK_2	Mode	R/W	PMA loopback, test FEF Generator and FEF Detector
		HW Rst	0	
		SW Rst	0	
0	PCS_LPBK	Mode	R/W	PCS loopback, test pcs_tx and pcs_rx
		HW Rst	0	
		SW Rst	0	

4.2.22 Hibernate Control Register

Offset: 0x1B

Bit	Name	Type		Description
15	Ps_hib_en	Mode	RO	Power hibernate control bit; '1' : hibernate enable '0' : hibernate disable
		HW Rst	0	
		SW Rst	0	
14	RES	Mode	RO	Reserved
		HW Rst	0	
		SW Rst	0	
13	RES	Mode	RO	Reserved
		HW Rst	0	
		SW Rst	0	
12	RES	Mode	RO	Reserved
		HW Rst	0	
		SW Rst	0	
11	RES	Mode	RO	Reserved
		HW Rst	0	
		SW Rst	0	
10	RES	Mode	RO	Reserved
		HW Rst	0	
		SW Rst	0	
9:0	RES	Mode	RO	Reserved
		HW Rst	0	
		SW Rst	0	

4.2.23 Power Saving Control

Offset: 0x29

Bit	Name	Type		Description
15	TOP_PS_EN	Mode	RO	'1' : Top level Power Saving Enable '0' : Top level Power Saving Disable
		HW Rst	1	
		SW Rst	Retain	
14:12	RES	Mode	R/W	Reserved
		HW Rst	3'h3	
		SW Rst	Retain	
11:9	Dac_amp_100	Mode	R/W	Control amplitude of transmit signal in 100BT mode. 000: -2% 111: +12%
		HW Rst	3'h3	
		SW Rst	Retain	
8:6	Dac_amp_10	Mode	R/W	Control amplitude of transmit signal in 10BT mode. 000: -2% 111: +12%
		HW Rst	3'h3	
		SW Rst	Retain	
5:1	RES	Mode	R/W	Reserved
		HW Rst	0	
		SW Rst	0	
0	RES	Mode	R/W	Reserved
		HW Rst	1	
		SW Rst	Retain	

5. Package Dimensions

The AR8032 is packaged in a QFN 32. The body size is 5 mm by 5 mm. The package drawings

and dimensions are provided in [Figure 5-1](#) and [Table 5-1](#).

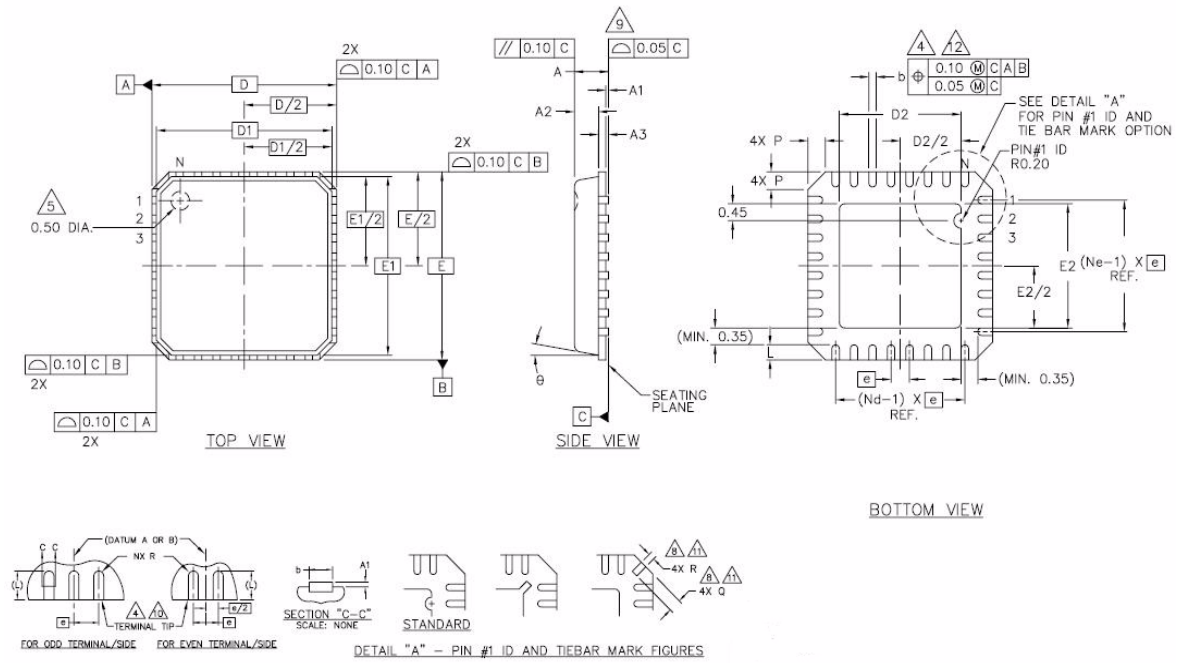

Figure 5-1. Package Views

Table 5-1. Package Dimensions

Dimension Label	Min	Nom	Max	Unit
A	0.80	0.85	0.90	mm
A1	0.00	0.01	0.05	mm
A2	0.60	0.65	0.70	mm
b	0.18	0.23	0.30	mm
D	5.00 Basic			mm
D1	4.75 Basic			mm
E	5.00 Basic			mm
E1	4.75 Basic			mm
P	0.24	0.42	0.60	mm
R	0.13	0.17	0.23	mm
Q	0.30	0.40	0.65	mm
D2	2.60	2.70	2.80	mm
E2	2.60	2.70	2.80	mm
θ	0	—	12	$^{\circ}$

Notes:

1. To be determined at seating plane C.
2. Dimensioning and tolerances conform to ASME Y14.5M — 1994.
3. Dimension b applies to plated terminal and is measured between 0.15 and 0.30mm from terminal tip.
4. The Pin #1 identifier must be on the top surface of the package using indentation mark or other feature of the package body.
5. All Dimensions are in millimeters.
6. The shape shown on four corners are not actual I/O.
7. Q and R applies only for straight tiebar shapes.

6. Ordering Information

The order number AR8032-AL1E specifies a current version of the AR8032.

The information in this document has been carefully reviewed and is believed to be accurate. Nonetheless, this document is subject to change without notice. Atheros assumes no responsibility for any inaccuracies that may be contained in this document, and makes no commitment to update or to keep current the contained information, or to notify a person or organization of any updates. Atheros reserves the right to make changes, at any time, to improve reliability, function or design and to attempt to supply the best product possible.

Document Number: 981-00072-001

MKG-0607 Rev. 1



Atheros Communications, Incorporated

5480 Great America Parkway
Santa Clara, CA 95054
t: 408/773-5200
f: 408/773-9940
www.atheros.com

