

## 21V, 1.8A, 600KHz Synchronous Step-Down DC/DC Converter

### Description

The FR9801 is a synchronous step-down DC/DC converter that provides wide 4.5V to 21V input voltage range and 1.8A continuous load current capability.

The FR9801 fault protection includes cycle-by-cycle current limit, UVLO, output overvoltage protection and thermal shutdown. The adjustable soft-start function prevents inrush current at turn-on. This device uses current mode control scheme which provides fast transient response. Internal Compensation function reduces external compensation components and simplifies the design process. In shutdown mode, the supply current is less than 1µA.

The FR9801 is available in a SOT-23-6 package, provides good thermal conductance.

### Features

- High Efficiency up to 94%
- Low Rds(on) Integrated Power MOSFET
- Internal Compensation Function
- Wide Input Voltage Range: 4.5V to 21V
- Adjustable Output Voltage from 0.8V to 17.85V
- 1.8A Output Current
- Fixed 600KHz Switching Frequency
- Current Mode Operation
- Cycle-by-Cycle Current Limit
- Over-Temperature Protection with Auto Recovery
- Output Overvoltage Protection
- Under Voltage Lockout
- <1µA Shutdown Current
- SOT-23-6 Package

### Applications

- STB (Set-Top-Box)
- LCD Displays, TVs
- Distributed Power Systems
- Networking, XDSL Modems

### Pin Assignments

S6 Package (SOT-23-6)

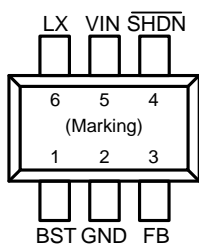
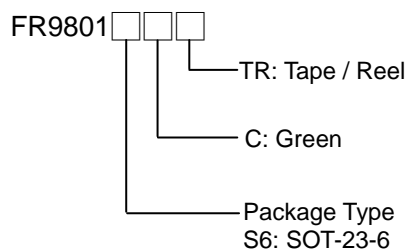

Figure 1. Pin Assignment of FR9801

### Ordering Information



#### SOT-23-6 Marking

Part Number	Product Code
FR9801S6CTR	B1G

**Typical Application Circuit**

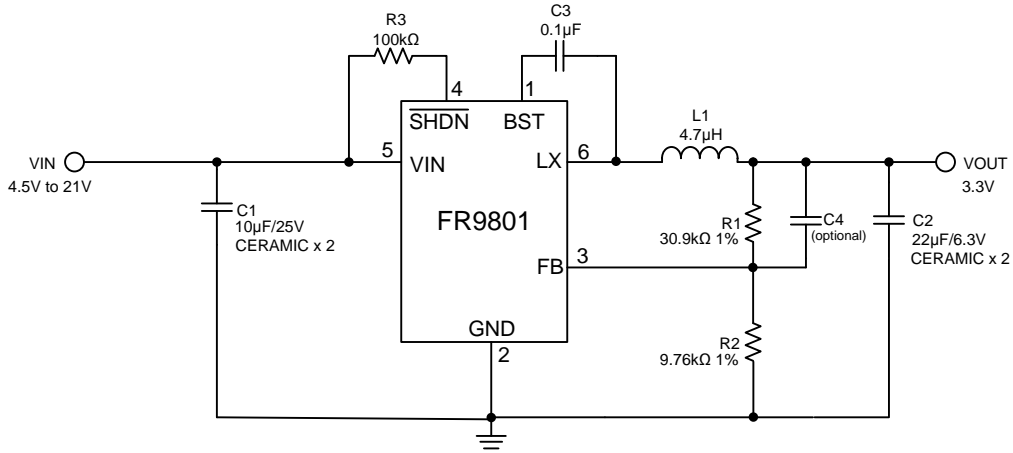

Figure 2.  $C_{IN}/C_{OUT}$  use Ceramic Capacitors Application Circuit

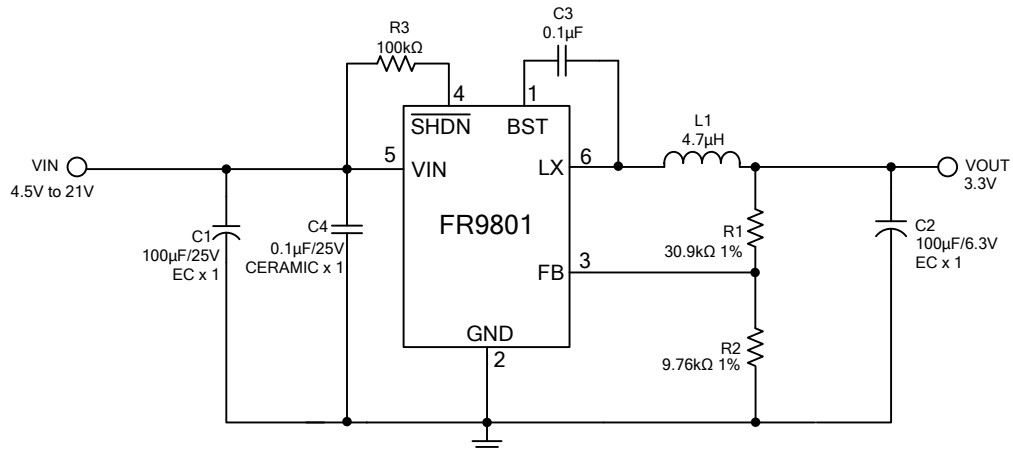

Figure 3.  $C_{IN}/C_{OUT}$  use Electrolytic Capacitors Application Circuit

$V_{OUT}$	R1	R2	C4	L1	$C_{OUT}$
1.2V	4.99kΩ	10kΩ	10pF~1nF	2.2μH	22μF MLCC x2
1.8V	4.99kΩ	3.92kΩ	10pF~1nF	2.2μH	22μF MLCC x2
2.5V	4.99kΩ	2.32kΩ	10pF~1nF	4.7μH	22μF MLCC x2
3.3V	30.9kΩ	9.76kΩ	10pF~1nF	4.7μH	22μF MLCC x2
5V	30.9kΩ	5.76kΩ	10pF~1nF	4.7μH	22μF MLCC x2
1.2V	4.99kΩ	10kΩ	--	2.2μH	100μF EC x1
1.8V	4.99kΩ	3.92kΩ	--	2.2μH	100μF EC x1
2.5V	4.99kΩ	2.32kΩ	--	4.7μH	100μF EC x1
3.3V	30.9kΩ	9.76kΩ	--	4.7μH	100μF EC x1
5V	30.9kΩ	5.76kΩ	--	4.7μH	100μF EC x1

Table 1. Recommended Component Values

## Functional Pin Description

I/O	Pin Name	Pin No.	Pin Function
I	FB	3	Voltage Feedback Input Pin. Connect FB and $V_{OUT}$ with a resistive voltage divider. This IC senses feedback voltage via FB and regulates it at 0.8V.
I	VIN	5	Power Supply Input Pin. Drive VIN pin by 4.5V to 21V voltage to power on the chip.
I	$\overline{\text{SHDN}}$	4	Enable Input Pin. This pin is a digital control input that turns the converter on or off. Connect to VIN with a 100K $\Omega$ resistor for self-startup.
I	GND	2	Ground Pin.
O	LX	6	Power Switching Output. LX is the output of the internal high side NMOS switch.
O	BST	1	High Side Gate Drive Boost Pin. A 10nF or greater capacitor must be connected from this pin to LX. It can boost the gate drive to fully turn on the internal high side NMOS.

## Block Diagram

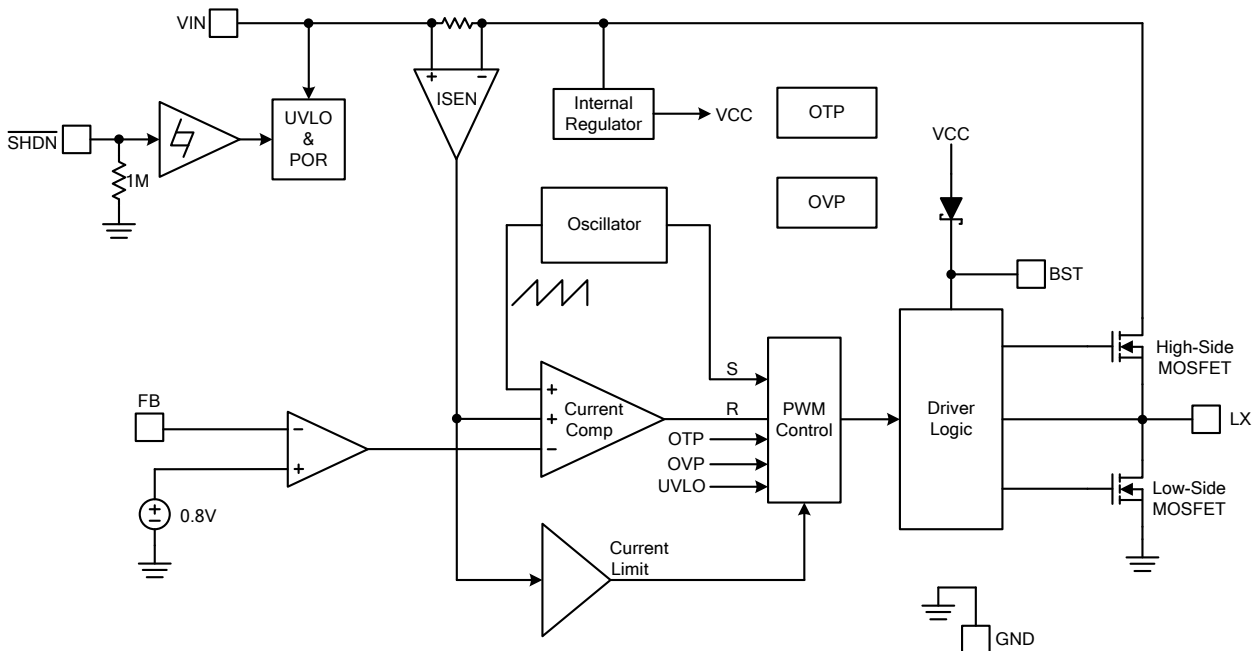

Figure 4. Block Diagram of FR9801

## Absolute Maximum Ratings (Note 1)

- Supply Voltage  $V_{IN}$  ----- -0.3V to +23V
- Enable Voltage  $V_{\overline{SHDN}}$  ----- -0.3V to +23V
- LX Voltage  $V_{LX}$  (50ns) ----- -1V to  $V_{IN}+0.3V$
- BST Pin Voltage  $V_{BST}$  -----  $V_{LX}-0.3V$  to  $V_{LX}+6V$
- All Other Pins Voltage ----- -0.3V to +6V
- Maximum Junction Temperature ( $T_J$ ) ----- +150°C
- Storage Temperature ( $T_S$ ) ----- -65°C to +150°C
- Lead Temperature (Soldering, 10sec.) ----- +260°C
- Power Dissipation @  $T_A=25^\circ C$ , ( $P_D$ )
  - SOT-23-6 ----- +0.40W
- Package Thermal Resistance, ( $\theta_{JA}$ ):
  - SOT-23-6 ----- +250°C/W
- Package Thermal Resistance, ( $\theta_{JC}$ ):
  - SOT-23-6 ----- +130°C/W

Note 1 : Stresses beyond this listed under "Absolute Maximum Ratings" may cause permanent damage to the device.

## Recommended Operating Conditions

- Supply Voltage  $V_{IN}$  ----- +4.5V to +21V
- Enable Voltage  $V_{\overline{SHDN}}$  ----- 0V to  $V_{IN}$
- Operation Temperature Range ----- -40°C to +85°C

## Electrical Characteristics

( $V_{IN}=12V$ ,  $T_A=25^{\circ}C$ , unless otherwise specified.)

Parameter	Symbol	Conditions	Min	Typ	Max	Unit
$V_{IN}$ Input Supply Voltage	$V_{IN}$		4.5		21	V
$V_{IN}$ Quiescent Current	$I_{DDQ}$	$V_{\overline{SHDN}}=1.8V$ , $V_{FB}=1.0V$		2.5		mA
$V_{IN}$ Shutdown Supply Current	$I_{SD}$	$V_{\overline{SHDN}}=0V$			1	$\mu A$
Feedback Voltage	$V_{FB}$	$4.5V \leq V_{IN} \leq 21V$	0.779	0.8	0.821	V
Feedback OVP Threshold Voltage	$V_{OVP}$			1.4		V
High-Side MOSFET $R_{DS(ON)}$ (Note 2)	$R_{DS(ON)}$			120		$m\Omega$
Low-Side MOSFET $R_{DS(ON)}$ (Note 2)	$R_{DS(ON)}$			110		$m\Omega$
High-Side MOSFET Leakage Current	$I_{LX(leak)}$	$V_{\overline{SHDN}}=0V$ , $V_{LX}=0V$			10	$\mu A$
High-Side MOSFET Current Limit (Note 2)	$I_{LIMIT(HS)}$	Minimum Duty	2.5	3		A
Low-Side MOSFET Current Limit (Note 2)	$I_{LIMIT(LS)}$	From Drain to Source		1.5		A
Error Amplifier Voltage Gain (Note 2)				400		V/V
Oscillation frequency	$F_{OSC}$		480	600	720	KHz
Short Circuit Oscillation Frequency	$F_{OSC(short)}$	$V_{FB}=0V$		140		KHz
Maximum Duty Cycle	$D_{MAX}$	$V_{FB}=0.6V$		90		%
Minimum On Time (Note 2)	$T_{MIN}$			100		ns
Input UVLO Threshold	$V_{UVLO(Vth)}$	$V_{IN}$ Rising		4.3		V
Under Voltage Lockout Threshold Hysteresis	$V_{UVLO(HYS)}$			400		mV
$\overline{SHDN}$ Input Low Voltage	$V_{\overline{SHDN}}(L)$				0.4	V
$\overline{SHDN}$ Input High Voltage	$V_{\overline{SHDN}}(H)$		2			V
$\overline{SHDN}$ Input Current	$I_{\overline{SHDN}}$	$V_{IN}=2V$		2		$\mu A$
Thermal Shutdown Threshold (Note 2)	$T_{SD}$			170		$^{\circ}C$

Note 2 : Not production tested.

**Outline Information**

SOT-23-6 Package (Unit: mm)

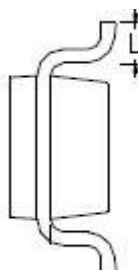
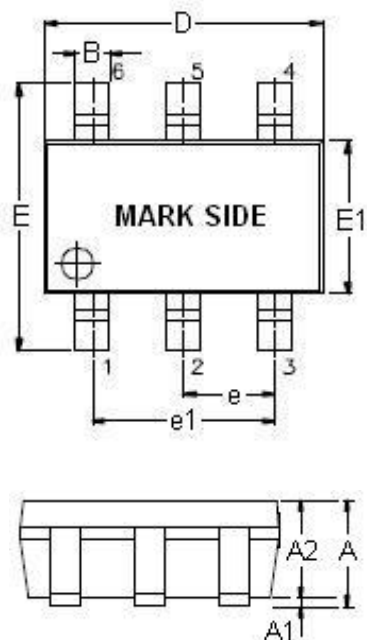

SYMBOLS UNIT	DIMENSION IN MILLIMETER	
	MIN	MAX
A	0.90	1.45
A1	0.00	0.15
A2	0.90	1.30
B	0.30	0.50
D	2.80	3.00
E	2.60	3.00
E1	1.50	1.70
e	0.90	1.00
e1	1.80	2.00
L	0.30	0.60

Note : Followed From JEDEC MO-178-C.

**Carrier dimensions**

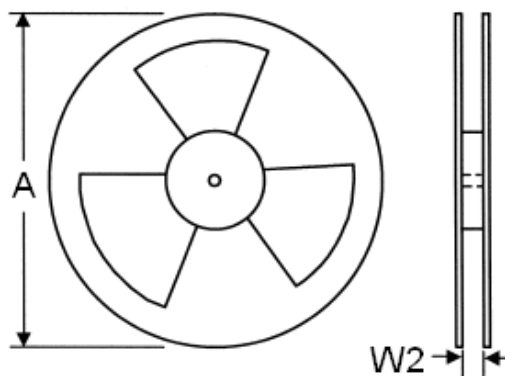
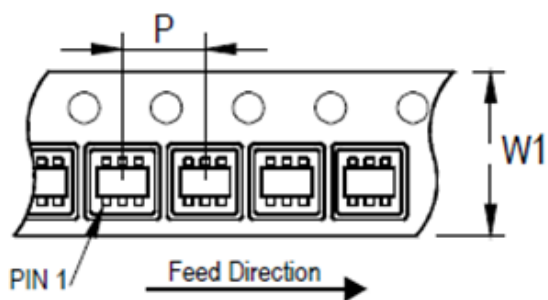

Tape Size (W1) mm	Pocket Pitch (P) mm	Reel Size (A)		Reel Width (W2) mm	Empty Cavity Length mm	Units per Reel
		in	mm			
8	4	7	180	8.4	300~1000	3,000

**Life Support Policy**

Fitipower's products are not authorized for use as critical components in life support devices or other medical systems.