

■ General Description

The AME1084 is a 5A low-dropout positive voltage regulator. It is available in fixed and adjustable output voltage versions. Overcurrent and thermal protection are integrated onto the chip. Output current will limit as it reaches the pre-set current or temperature limit. At full rated output current the dropout voltage is 1.4V (max.). AME1084 series regulators provide excellent regulation over line, load and temperature variations.

■ Features

- Low Dropout Voltage ----- 1.4V at 5A
- Adjustable or 3.3V Fixed Voltage
- Line Regulation Typically 0.015%
- Load Regulation Typically 0.05%
- Adjust Pin (ADJ) Current Less than 90 μ A
- Overcurrent Protection
- Thermal Protection
- Available in TO-220, TO-263, TO-252
- All AME' s Lead Free Products Meet RoHS Standards

■ Applications

- High Efficiency Linear Regulators
- Post Regulators for Switching Supplies
- 5V to 3.3V Voltage Converter
- Battery Charger

■ Functional Block Diagram

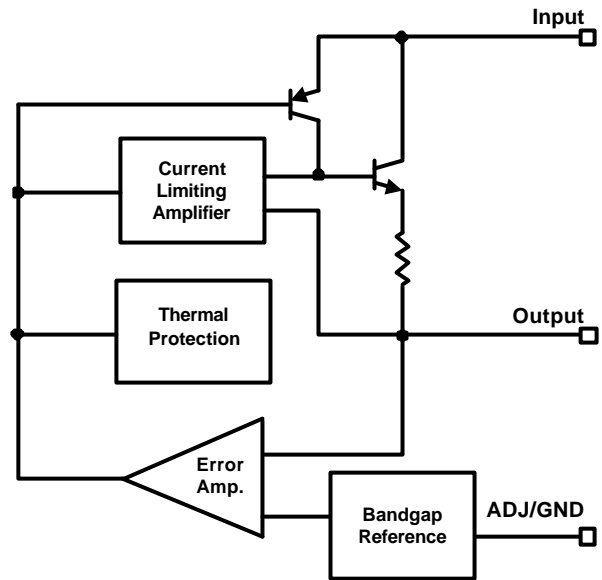

■ Typical Application

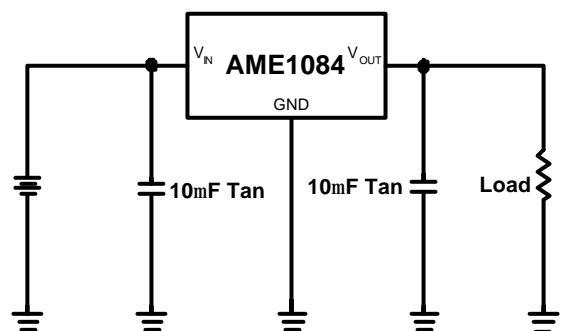

■ **Pin Configuration**

**TO-220-3
Front View**

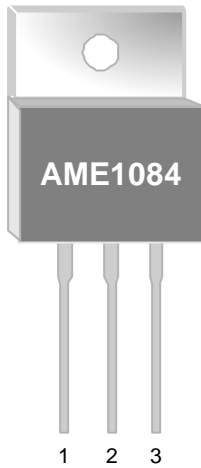

- AME1084**
1. ADJ / GND
 2. OUT (TAB)
 3. IN

* **Die Attach:**
Conductive Epoxy

**TO-252-2
Front View**

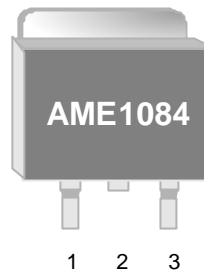

- AME1084**
1. ADJ / GND
 2. OUT (TAB)
 3. IN

* **Die Attach:**
Conductive Epoxy

**TO-252-3
Front View**

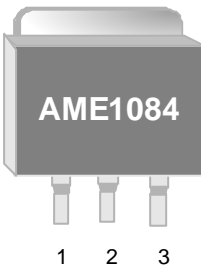

- AME1084**
1. ADJ / GND
 2. OUT (TAB)
 3. IN

* **Die Attach:**
Conductive Epoxy

**TO-263-2
Front View**

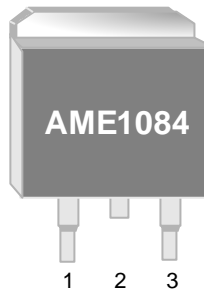

- AME1084**
1. ADJ / GND
 2. OUT (TAB)
 3. IN

* **Die Attach:**
Conductive Epoxy

**TO-263-3
Front View**

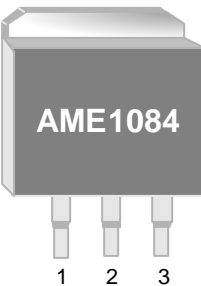

- AME1084**
1. ADJ / GND
 2. OUT (TAB)
 3. IN

* **Die Attach:**
Conductive Epoxy



■ Ordering Information

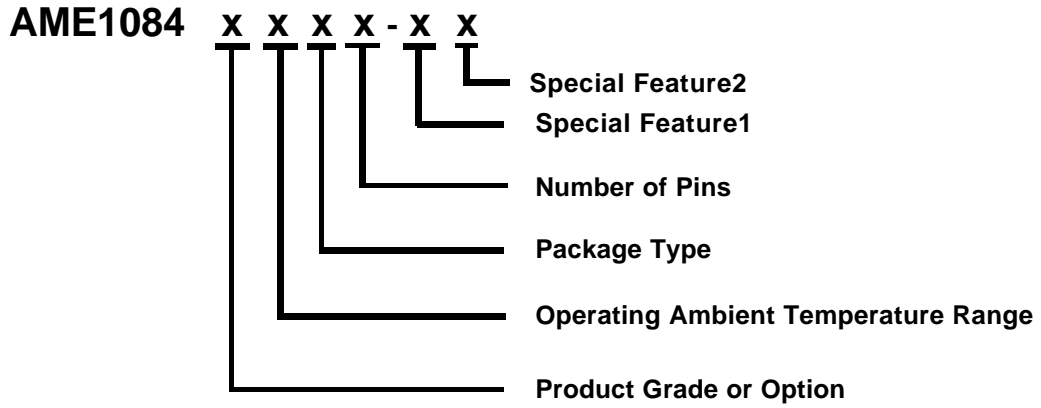

Product Grade or Option	Operating Ambient Temperature Range	Package Type	Number of Pins	Special Feature1	Special Feature2
A: ADJ B: 1.5V C: 2.5V D: 3.3V	C: 0°C to 70°C	B: TO-220 C: TO-252 D: TO-263	T: 3	3: TO-263-3 TO-252-3	Z: Lead Free



AME1084

■ Ordering Information (contd.)

Part Number	Marking*	Output Voltage	Package	Operating Ambient Temperature Range
AME1084ACBT	AME1084 ACBT yyww	ADJ	TO-220-3	0°C to 70°C
AME1084ACBTZ	AME1084 ACBT yyww	ADJ	TO-220-3	0°C to 70°C
AME1084BCBT	AME1084 BCBT yyww	1.5	TO-220-3	0°C to 70°C
AME1084BCBTZ	AME1084 BCBT yyww	1.5	TO-220-3	0°C to 70°C
AME1084CCBT	AME1084 CCBT yyww	2.5	TO-220-3	0°C to 70°C
AME1084CCBTZ	AME1084 CCBT yyww	2.5	TO-220-3	0°C to 70°C
AME1084DCBT	AME1084 DCBT yyww	3.3	TO-220-3	0°C to 70°C
AME1084DCBTZ	AME1084 DCBT yyww	3.3	TO-220-3	0°C to 70°C
AME1084ECBT	AME1084 ECBT yyww	1.8	TO-220-3	0°C to 70°C
AME1084ECBTZ	AME1084 ECBT yyww	1.8	TO-220-3	0°C to 70°C
AME1084ACDT-3	AME1084 ACDT-3 yyww	ADJ	TO-263-3	0°C to 70°C
AME1084ACDT-3Z	AME1084 ACDT-3 yyww	ADJ	TO-263-3	0°C to 70°C

Note: yyww represents the date code

* A line on top of the first letter represents lead free plating such as AME1084

Please consult AME sales office or authorized Rep./Distributor for the availability of voltage and package type .

■ Ordering Information (contd.)

Part Number	Marking*	Output Voltage	Package	Operating Ambient Temperature Range
AME1084BCDT-3	AME1084 BCDT-3 yyww	1.5	TO-263-3	0°C to 70°C
AME1084BCDT-3Z	AME1084 BCDT-3 yyww	1.5	TO-263-3	0°C to 70°C
AME1084CCDT-3	AME1084 CCDT-3 yyww	2.5	TO-263-3	0°C to 70°C
AME1084CCDT-3Z	AME1084 CCDT-3 yyww	2.5	TO-263-3	0°C to 70°C
AME1084DCDT-3	AME1084 DCDT-3 yyww	3.3	TO-263-3	0°C to 70°C
AME1084DCDT-3Z	AME1084 DCDT-3 yyww	3.3	TO-263-3	0°C to 70°C
AME1084ECDT-3	AME1084 ECDT-3 yyww	1.8	TO-263-3	0°C to 70°C
AME1084ECDT-3Z	AME1084 ECDT-3 yyww	1.8	TO-263-3	0°C to 70°C
AME1084ACDT	AME1084 ACDT yyww	ADJ	TO-263-2	0°C to 70°C
AME1084ACDTZ	AME1084 ACDT yyww	ADJ	TO-263-2	0°C to 70°C
AME1084BCDT	AME1084 BCDT yyww	1.5	TO-263-2	0°C to 70°C
AME1084BCDTZ	AME1084 BCDT yyww	1.5	TO-263-2	0°C to 70°C
AME1084CCDT	AME1084 CCDT yyww	2.5	TO-263-2	0°C to 70°C
AME1084CCDTZ	AME1084 CCDT yyww	2.5	TO-263-2	0°C to 70°C



■ Ordering Information

Part Number	Marking*	Output Voltage	Package	Operating Ambient Temperature Range
AME1084DCDT	AME1084 DCDT yyww	3.3	TO-263-2	0°C to 70°C
AME1084DCDTZ	AME1084 DCDT yyww	3.3	TO-263-2	0°C to 70°C
AME1084ECDT	AME1084 ECDT yyww	1.8	TO-263-2	0°C to 70°C
AME1084ECDTZ	AME1084 ECDT yyww	1.8	TO-263-2	0°C to 70°C
AME1084ACCT	AME1084 ACCT yyww	ADJ	TO-252-2	0°C to 70°C
AME1084ACCTZ	AME1084 ACCT yyww	ADJ	TO-252-2	0°C to 70°C
AME1084BCCT	AME1084 BCCT yyww	1.5	TO-252-2	0°C to 70°C
AME1084BCCTZ	AME1084 BCCT yyww	1.5	TO-252-2	0°C to 70°C
AME1084CCCT	AME1084 CCCT yyww	2.5	TO-252-2	0°C to 70°C
AME1084CCCTZ	AME1084 CCCT yyww	2.5	TO-252-2	0°C to 70°C
AME1084DCCT	AME1084 DCCT yyww	3.3	TO-252-2	0°C to 70°C
AME1084DCCTZ	AME1084 DCCT yyww	3.3	TO-252-2	0°C to 70°C
AME1084ECCT	AME1084 ECCT yyww	1.8	TO-252-2	0°C to 70°C
AME1084ECCTZ	AME1084 ECCT yyww	1.8	TO-252-2	0°C to 70°C



AME, Inc.

AME1084

**5A Low Dropout
Positive Voltage Regulator**

■ Ordering Information

Part Number	Marking*	Output Voltage	Package	Operating Ambient Temperature Range
AME1084DCCT-3Z	AME1084 DCCT-3 yyww	3.3	TO-252-3	0°C to 70°C



■ Absolute Maximum Ratings

Parameter	Package	Die Attach	Symbol	Maximum	Unit
Input Voltage			V_{IN}	12	V
Thermal Resistance* (Junction to Case)	TO-220-3	Conductive Epoxy	θ_{JC}	6	°C/W
	TO-252-2			5	
	TO-252-3				
	TO-263-2			5	
TO-263-3					
Thermal Resistance (Junction to Ambient)	TO-220-3	Conductive Epoxy	θ_{JA}	55	
	TO-252-2			90	
	TO-252-3				
	TO-263-2			80	
TO-263-3					
Internal Power Dissipation	TO-220-3	Conductive Epoxy	P_D	2200	mW
	TO-252-2			1200	
	TO-252-3				
	TO-263-2			1700	
TO-263-3					
Operating Junction Temperature Range			T_J	0 to 125	°C
Storage Temperature Range			T_{STG}	- 65 to 150	
Solder Iron (10 Sec)**				350	

Caution: Stress above the listed absolute maximum rating may cause permanent damage to the device

* Measure θ_{JC} on backside center of tab.

** MIL-STD-202G 210F

■ Electrical Specifications
AME1084Axxx

Parameter	Symbol	Test Condition		Min	Typ	Max	Units
Reference voltage (adjustable voltage)	V_{REF}	$V_{IN} = V_{OUT} + 1.5V \sim 12V,$ $I_O = 10mA$	$T_J = 25^\circ C$	1.238	1.250	1.262	V
			$0^\circ C \sim 70^\circ C$	1.225		1.275	
Line regulation	Reg_{LINE}	$V_{IN} = V_{OUT} + 1.5V \sim 12V,$ $I_O = 10mA$	$0^\circ C \sim 70^\circ C$	-	0.015	0.2	%
Load regulation	Reg_{LOAD}	$V_{IN} = V_{OUT} + 1.5V \sim 12V,$ $I_O = 10mA \sim 5A$	$0^\circ C \sim 70^\circ C$	-	0.05	0.3	%
Dropout voltage $\Delta V_{OUT}, \Delta V_{REF} = 1\%$	V_D	$I_O = 10mA \sim 5A$	$0^\circ C \sim 70^\circ C$	-	1.2	1.4	V
Current limit	I_S	$V_{IN} = V_{OUT} + 1.5V \sim 12V$	$0^\circ C \sim 70^\circ C$	5.0	-	-	A
Temperature Coefficient	T_C	$V_{IN} = V_{OUT} + 1.5V \sim 12V, I_O = 10mA \sim 5A$		-	0.005	-	%/ $^\circ C$
Adjust pin current	I_{ADJ}	$V_{IN} = V_{OUT} + 1.5V \sim 12V,$ $I_O = 10mA \sim 5A$	$0^\circ C \sim 70^\circ C$	-	55	120	μA
Adjust pin current change	ΔI_{ADJ}	$V_{IN} = V_{OUT} + 1.5V \sim 12V,$ $I_O = 10mA \sim 5A$	$0^\circ C \sim 70^\circ C$	-	0.2	5	
Temperature stability	T_S	$V_{IN} = 5V, I_O = 500mA$	$0^\circ C \sim 70^\circ C$	-	0.5	-	%
Minimum load current	I_O	$V_{IN} = 5V$		10	-	-	mA
RMS output noise	V_N	$T_J = 25^\circ C$		-	0.003	-	% V_O
Ripple rejection ratio	R_A	$V_{IN} = 5V, I_O = 5A$	$0^\circ C \sim 70^\circ C$	-	72	-	dB

AME1084Bxxx

Parameter	Symbol	Test Condition		Min	Typ	Max	Units
Output voltage (fixed voltage)	V_O	$V_{IN} = 3V, I_O = 0A$	$T_J = 25^\circ C$	1.485	1.500	1.515	V
			$0^\circ C \sim 70^\circ C$	1.470		1.530	
Line regulation	Reg_{LINE}	$V_{IN} = 3V \sim 12V, I_O = 0A$	$0^\circ C \sim 70^\circ C$	-	0.015	0.2	%
Load regulation	Reg_{LOAD}	$V_{IN} = 3V \sim 12V$ $I_O = 0A \sim 5A$	$0^\circ C \sim 70^\circ C$	-	0.05	0.3	%
Dropout voltage $\Delta V_{OUT}, \Delta V_{REF} = 1\%$	V_D	$I_O = 0A \sim 5A$	$0^\circ C \sim 70^\circ C$	-	1.2	1.4	V
Current limit	I_S	$V_{IN} = 3V \sim 12V$	$0^\circ C \sim 70^\circ C$	5.0	-	-	A
Quiescent current (fixed model)	I_Q	$V_{IN} = 5V, I_O = 0A \sim 5A$	$0^\circ C \sim 70^\circ C$	-	12	13	mA
Temperature Coefficient	T_C	$V_{IN} = 3V \sim 12V, I_O = 0A \sim 5A$		-	0.005	-	%/ $^\circ C$
Temperature stability	T_S	$V_{IN} = 5V, I_O = 500mA$	$0^\circ C \sim 70^\circ C$	-	0.5	-	%
RMS output noise	V_N	$T_J = 25^\circ C$		-	0.003	-	% V_O
Ripple rejection ratio	R_A	$V_{IN} = 5V, I_O = 5A$	$0^\circ C \sim 70^\circ C$	-	72	-	dB

AME1084
■ Electrical Specifications (contd.)
AME1084Cxxx

Parameter	Symbol	Test Condition	Min	Typ	Max	Units	
Output voltage (fixed voltage)	V _O	V _{IN} = 4V~12V, I _O = 0A	T _J = 25°C	2.475	2.500	2.525	V
			0°C~70°C	2.450		2.550	
Line regulation	Reg _{LINE}	V _{IN} = 4V~12V, I _O = 0A	0°C~70°C	-	0.015	0.2	%
Load regulation	Reg _{LOAD}	V _{IN} = 4V~12V I _O = 0A~5A	0°C~70°C	-	0.05	0.3	%
Dropout voltage ΔV _{OUT} , ΔV _{REF} = 1%	V _D	I _O = 0A ~ 5A	0°C~70°C	-	1.2	1.4	V
Current limit	I _S	V _{IN} = 4V~12V	0°C~70°C	5.0	-	-	A
Quiescent current (fixed model)	I _Q	V _{IN} = 5V, I _O = 0A~5A	0°C~70°C	-	12	13	mA
Temperature Coefficient	T _C	V _{IN} = 4V~12V, I _O = 0A~5A	-	0.005	-	%/°C	
Temperature stability	T _S	V _{IN} = 5V, I _O = 500mA	0°C~70°C	-	0.5	-	%
RMS output noise	V _N	T _J = 25°C	-	0.003	-	%V _O	
Ripple rejection ratio	R _A	V _{IN} = 5V, I _O = 5A	0°C~70°C	-	72	-	dB

AME1084Dxxx

Parameter	Symbol	Test Condition	Min	Typ	Max	Units	
Output voltage (fixed voltage)	V _O	V _{IN} = 4.8V~12V, I _O = 0A	T _J = 25°C	3.267	3.300	3.333	V
			0°C~70°C	3.234		3.366	
Line regulation	Reg _{LINE}	V _{IN} = 4.8V~12V, I _O = 0A	0°C~70°C	-	0.015	0.2	%
Load regulation	Reg _{LOAD}	V _{IN} = 4.8V~12V I _O = 0A~5A	0°C~70°C	-	0.05	0.3	%
Dropout voltage ΔV _{OUT} , ΔV _{REF} = 1%	V _D	I _O = 0A ~ 5A	0°C~70°C	-	1.2	1.4	V
Current limit	I _S	V _{IN} = 4.8V~12V	0°C~70°C	5.0	-	-	A
Quiescent current (fixed model)	I _Q	V _{IN} = 5V, I _O = 0A~5A	0°C~70°C	-	12	13	mA
Temperature Coefficient	T _C	V _{IN} = 4.8V~12V, I _O = 0A~5A	-	0.005	-	%/°C	
Temperature stability	T _S	V _{IN} = 5V, I _O = 500mA	0°C~70°C	-	0.5	-	%
RMS output noise	V _N	T _J = 25°C	-	0.003	-	%V _O	
Ripple rejection ratio	R _A	V _{IN} = 5V, I _O = 5A	0°C~70°C	-	72	-	dB

■ Electrical Specifications
AME1084Exxx

Parameter	Symbol	Test Condition	Min	Typ	Max	Units	
Output voltage	V_O	$V_{IN} = 3.3V \sim 12V, I_O = 0A$	$T_J = 25^\circ C$	1.782	1.800	1.818	V
			$0^\circ C \sim 70^\circ C$	1.764	1.800	1.836	
Line regulation	Reg_{LINE}	$V_{IN} = 3.3V \sim 12V, I_O = 0A$	$0^\circ C \sim 70^\circ C$	-	0.015	0.2	%
Load regulation	Reg_{LOAD}	$V_{IN} = 3.3V \sim 12V$ $I_O = 0A \sim 5A$	$0^\circ C \sim 70^\circ C$	-	0.05	0.3	
Dropout voltage	V_D	$I_O = 0A \sim 5A,$	$0^\circ C \sim 70^\circ C$	-	1.2	1.4	V
Current limit	I_S	$V_{IN} = 3.3V \sim 12V$	$0^\circ C \sim 70^\circ C$	5.0	-	-	A
Quiescent Current	I_Q	$V_{IN} = 5V, I_O = 0A \sim 5A$	$0^\circ C \sim 70^\circ C$	-	12	13	mA
Temp. Coefficient	T_C	$V_{IN} = 3.3V \sim 12V, I_O = 0A \sim 5A$		-	0.005	-	%/ $^\circ C$
Temperature stability	T_S	$V_{IN} = 5V, I_O = 500mA$	$0^\circ C \sim 70^\circ C$	-	0.5	-	%
RMS output noise	V_N	$T_J = 25^\circ C$		-	0.003	-	% V_O
Ripple rejection ratio	R_A	$V_{IN} = 5V, I_O = 5A$	$0^\circ C \sim 70^\circ C$	-	72	-	dB

■ Application Description

1. Output Voltage Adjustment

Like most regulators, the AME1084 regulates the output by comparing the output voltage to an internally generated reference voltage. On the adjustable version, the V_{REF} is available externally as 1.25V between V_{OUT} and ADJ. The voltage ratio formed by R1 and R2 should be set to conduct 10mA (minimum output load). The output voltage is given by the following equation:

$$V_{OUT} = V_{REF} \left(1 + \frac{R2}{R1} \right) + I_{ADJ} \times R2$$

On fixed versions of AME1084, the voltage divider is provided internally.

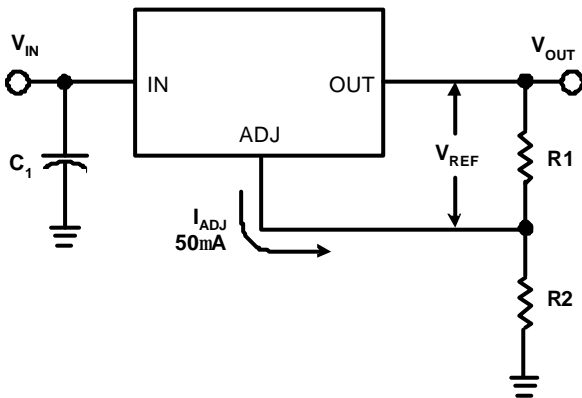

$$V_{OUT} = V_{REF} \left(1 + \frac{R2}{R1} \right) + I_{ADJ} \times R2$$

2. Thermal Protection

AME1084 has thermal protection which limits junction temperature to 150°C. However, device functionality is only guaranteed to a maximum junction temperature of +125°C.

The power dissipation and junction temperature for AME1084 in TO-220 package are given by

$$P_D = (V_{IN} - V_{OUT}) \times I_{OUT}$$

$$T_{JUNCTION} = T_{AMBIENT} + (P_D \times \theta_{JA})$$

Note: $T_{JUNCTION}$ must not exceed 125°C

3. Current Limit Protection

AME1084 is protected against overload conditions. Current protection is triggered at typical 7.5A.

4. Stability and Load Regulation

AME1084 requires a capacitor from V_{OUT} to GND to provide compensation feedback to the internal gain stage. This is to ensure stability at the output terminal. Typically, a 10µF tantalum or 50µF aluminum electrolytic is sufficient.

(Note: It is important that the ESR for this capacitor does not exceed 0.5W.)

The output capacitor does not have a theoretical upper limit and increasing its value will increase stability. $C_{OUT} = 100\mu\text{F}$ or more is typical for high current regulator design.

For the adjustable version, the best load regulation is accomplished when the top of the resistor divider (R1) is connected directly to the output pin of the AME1084. When so connected, R_p is not multiplied by the divider ratio.

For fixed output versions, the top of R1 is internally connected to the output. The ground pin can be connected to low side of the load to eliminate ground loop errors.

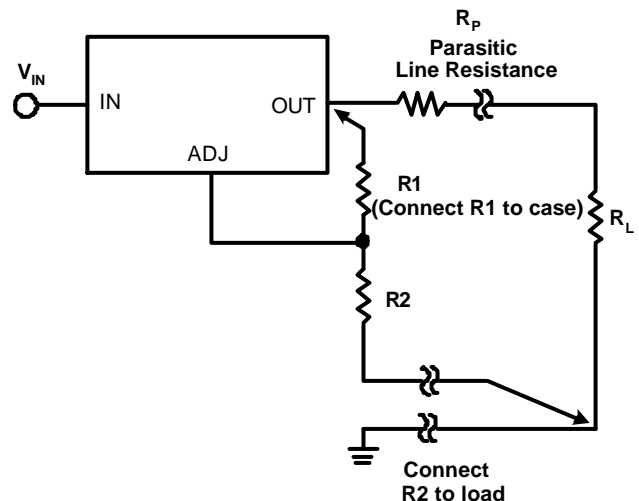



5. Thermal Consideration

The AME1084 series contain thermal limiting circuitry designed to protect itself for over-temperature conditions. Even for normal load conditions, maximum junction temperature ratings must not be exceeded. As mention in thermal protection section, we need to consider all sources of thermal resistance between junction and ambient. It includes junction-to-case, case-to-heat-sink interface and heat sink thermal resistance itself.

Junction-to-case thermal resistance is specified from the IC junction to the bottom of the case directly below the die. Proper mounting is required to ensure the best possible thermal flow from this area of the package to the heat sink. The case of all devices in this series is electrically connected to the output. Therefore, if the case of the device must be electrically isolated, a thermally conductive spacer is recommended.

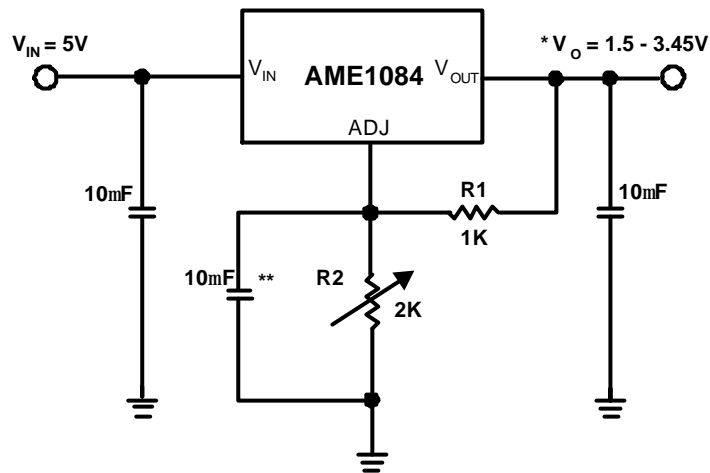
■ Advanced Applications
Adjustable Output Voltage

Note: $* V_{OUT} = V_{REF} \left(1 + \frac{R2}{R1} \right) + I_{ADJ} \times R2$

** Optional for improved ripple rejection

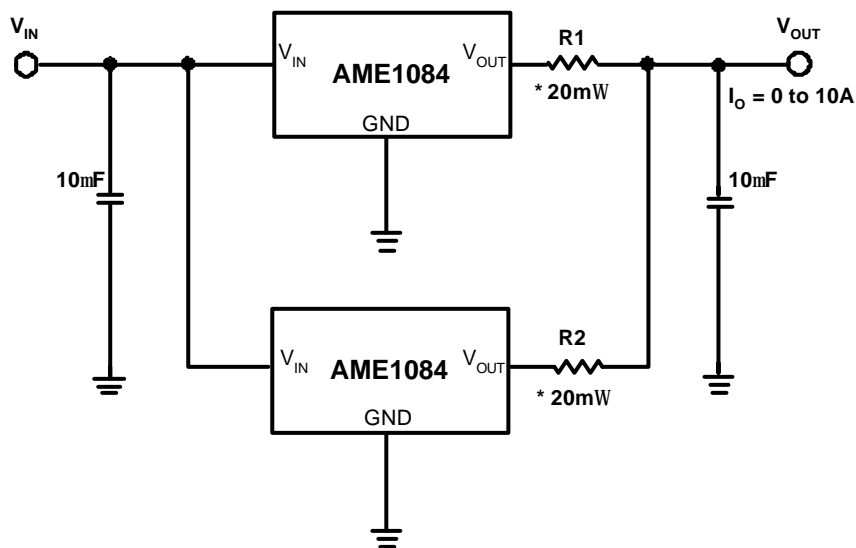
Paralleling Regulators

Note: * 20mΩ is ballast resistance
The inter - connection of #18 wire could act as ballast resistance



■ Advanced Applications (contd.)

Regulator with Reference

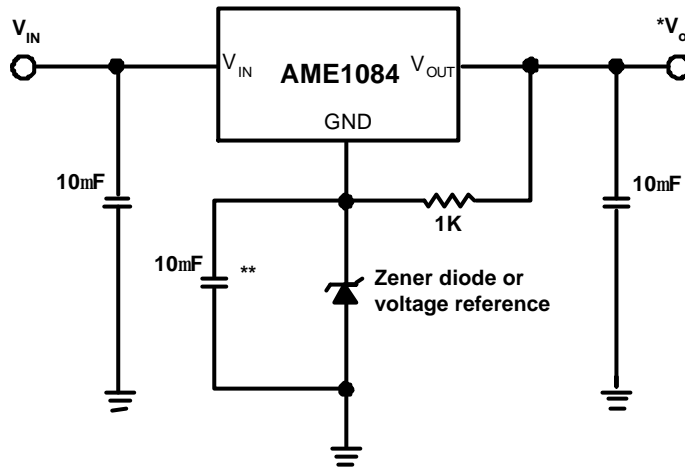

Note: * $V_o = V_{REF} + V_Z$ (V_Z : breakdown voltage of Zener diode)
** Optional for improved ripple rejection

Regulator with Reverse Diode Protection

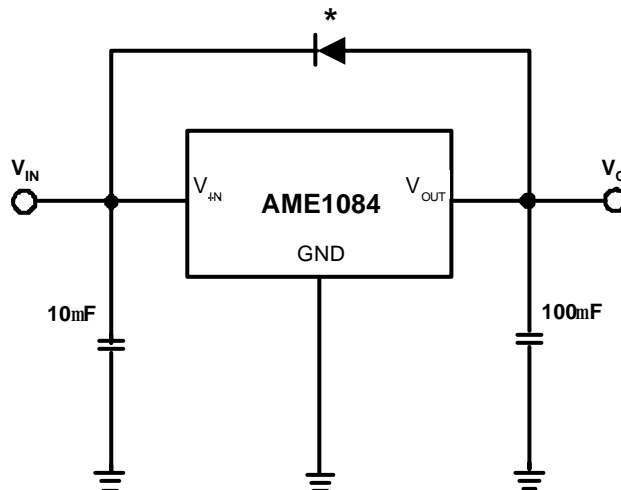



■ Performance Characteristics

Drop Out Voltage vs. Load Current

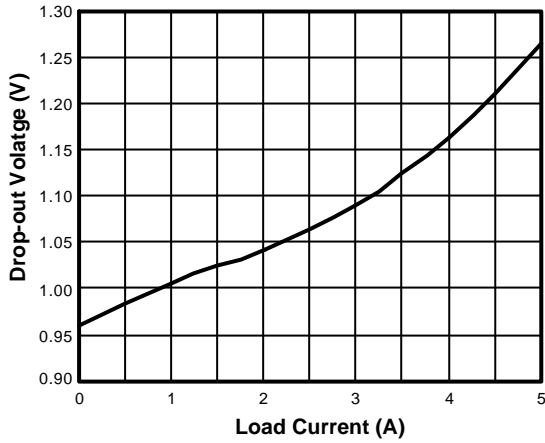

Minimum Operation Current vs. Input/Output Differential Voltage

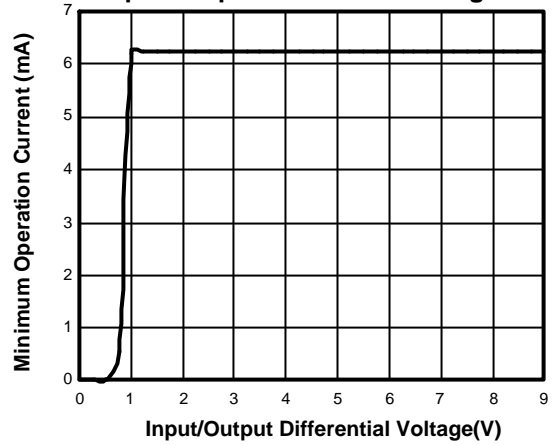

Output Short Circuit Current vs. Input/Output Differential Voltage

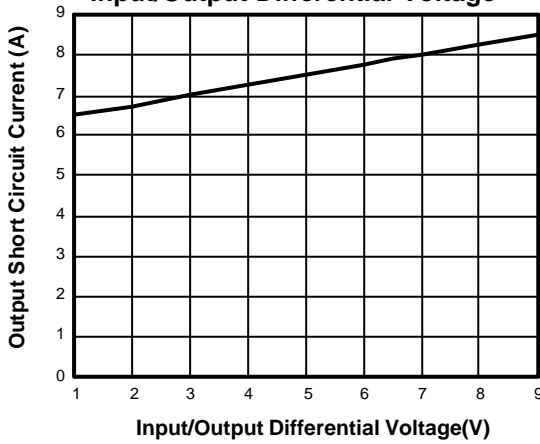

■ External Resistor Divider Table for Customized Voltage (contd.)

R1 (Ohm)	100	102	105	107	110	113	115	118	121	124
Vout	R2(Ohm)=(Vout-1.25)*R1/(1.25+50u*R1)									
1.25	0.000	0.000	0.000	0.000	0.000	0.000	0.000	0.000	0.000	0.000
1.30	3.984	4.063	4.182	4.262	4.381	4.500	4.579	4.698	4.817	4.936
1.35	7.968	8.127	8.365	8.524	8.761	8.999	9.158	9.396	9.633	9.871
1.40	11.95	12.19	12.55	12.79	13.14	13.50	13.74	14.09	14.45	14.81
1.45	15.94	16.25	16.73	17.05	17.52	18.00	18.32	18.79	19.27	19.74
1.50	19.92	20.32	20.91	21.31	21.90	22.50	22.89	23.49	24.08	24.68
1.55	23.90	24.38	25.09	25.57	26.28	27.00	27.47	28.19	28.90	29.61
1.60	27.89	28.44	29.28	29.83	30.67	31.50	32.05	32.88	33.72	34.55
1.65	31.87	32.51	33.46	34.09	35.05	36.00	36.63	37.58	38.53	39.48
1.70	35.86	36.57	37.64	38.36	39.43	40.50	41.21	42.28	43.35	44.42
1.75	39.84	40.63	41.82	42.62	43.81	45.00	45.79	46.98	48.17	49.36
1.80	43.82	44.70	46.01	46.88	48.19	49.50	50.37	51.68	52.98	54.29
1.85	47.81	48.76	50.19	51.14	52.57	54.00	54.95	56.37	57.80	59.23
1.90	51.79	52.82	54.37	55.40	56.95	58.50	59.53	61.07	62.62	64.16
1.95	55.78	56.89	58.55	59.66	61.33	63.00	64.11	65.77	67.43	69.10
2.00	59.76	60.95	62.74	63.93	65.71	67.49	68.68	70.47	72.25	74.03
2.05	63.75	65.01	66.92	68.19	70.09	71.99	73.26	75.17	77.07	78.97
2.10	67.73	69.08	71.10	72.45	74.47	76.49	77.84	79.86	81.88	83.90
2.15	71.71	73.14	75.28	76.71	78.85	80.99	82.42	84.56	86.70	88.84
2.20	75.70	77.21	79.47	80.97	83.23	85.49	87.00	89.26	91.52	93.77
2.25	79.68	81.27	83.65	85.24	87.61	89.99	91.58	93.96	96.33	98.71
2.30	83.67	85.33	87.83	89.50	92.00	94.49	96.16	98.65	101.2	103.6
2.35	87.65	89.40	92.01	93.76	96.38	98.99	100.7	103.4	106.0	108.6
2.40	91.63	93.46	96.20	98.02	100.8	103.5	105.3	108.1	110.8	113.5
2.45	95.62	97.52	100.4	102.3	105.1	108.0	109.9	112.7	115.6	118.5
2.50	99.60	101.6	104.6	106.5	109.5	112.5	114.5	117.4	120.4	123.4
2.55	103.6	105.6	108.7	110.8	113.9	117.0	119.1	122.1	125.2	128.3
2.60	107.6	109.7	112.9	115.1	118.3	121.5	123.6	126.8	130.1	133.3
2.65	111.6	113.8	117.1	119.3	122.7	126.0	128.2	131.5	134.9	138.2
2.70	115.5	117.8	121.3	123.6	127.0	130.5	132.8	136.2	139.7	143.1
2.75	119.5	121.9	125.5	127.9	131.4	135.0	137.4	140.9	144.5	148.1
2.80	123.5	126.0	129.7	132.1	135.8	139.5	141.9	145.6	149.3	153.0
2.85	127.5	130.0	133.8	136.4	140.2	144.0	146.5	150.3	154.1	157.9
2.90	131.5	134.1	138.0	140.6	144.6	148.5	151.1	155.0	159.0	162.9
2.95	135.5	138.2	142.2	144.9	148.9	153.0	155.7	159.7	163.8	167.8
3.00	139.4	142.2	146.4	149.2	153.3	157.5	160.3	164.4	168.6	172.7
3.05	143.4	146.3	150.6	153.4	157.7	162.0	164.8	169.1	173.4	177.7
3.10	147.4	150.3	154.8	157.7	162.1	166.5	169.4	173.8	178.2	182.6



External Resistor Divider Table for Customized Voltage

R1 (Ohm)	100	102	105	107	110	113	115	118	121	124
Vout	$R2(Ohm)=(Vout-1.25)*R1/(1.25+50u*R1)$									
3.15	151.4	154.4	158.9	161.9	166.5	171.0	174.0	178.5	183.0	187.5
3.20	155.4	158.5	163.1	166.2	170.8	175.5	178.6	183.2	187.9	192.5
3.25	159.4	162.5	167.3	170.5	175.2	180.0	183.2	187.9	192.7	197.4
3.30	163.3	166.6	171.5	174.7	179.6	184.5	187.7	192.6	197.5	202.4
3.35	167.3	170.7	175.7	179.0	184.0	189.0	192.3	197.3	202.3	207.3
3.40	171.3	174.7	179.8	183.3	188.4	193.5	196.9	202.0	207.1	212.2
3.45	175.3	178.8	184.0	187.5	192.8	198.0	201.5	206.7	211.9	217.2
3.50	179.3	182.9	188.2	191.8	197.1	202.5	206.1	211.4	216.8	222.1
3.55	183.3	186.9	192.4	196.0	201.5	207.0	210.6	216.1	221.6	227.0
3.60	187.3	191.0	196.6	200.3	205.9	211.5	215.2	220.8	226.4	232.0
3.65	191.2	195.0	200.8	204.6	210.3	216.0	219.8	225.5	231.2	236.9
3.70	195.2	199.1	204.9	208.8	214.7	220.5	224.4	230.2	236.0	241.8
3.75	199.2	203.2	209.1	213.1	219.0	225.0	228.9	234.9	240.8	246.8
3.80	203.2	207.2	213.3	217.3	223.4	229.5	233.5	239.6	245.7	251.7
3.85	207.2	211.3	217.5	221.6	227.8	234.0	238.1	244.3	250.5	256.6
3.90	211.2	215.4	221.7	225.9	232.2	238.5	242.7	249.0	255.3	261.6
3.95	215.1	219.4	225.9	230.1	236.6	243.0	247.3	253.7	260.1	266.5
4.00	219.1	223.5	230.0	234.4	240.9	247.5	251.8	258.4	264.9	271.5
4.05	223.1	227.6	234.2	238.7	245.3	252.0	256.4	263.1	269.7	276.4
4.10	227.1	231.6	238.4	242.9	249.7	256.5	261.0	267.8	274.6	281.3
4.15	231.1	235.7	242.6	247.2	254.1	261.0	265.6	272.5	279.4	286.3
4.20	235.1	239.7	246.8	251.4	258.5	265.5	270.2	277.2	284.2	291.2
4.25	239.0	243.8	250.9	255.7	262.8	270.0	274.7	281.9	289.0	296.1
4.30	243.0	247.9	255.1	260.0	267.2	274.5	279.3	286.6	293.8	301.1
4.35	247.0	251.9	259.3	264.2	271.6	279.0	283.9	291.3	298.6	306.0
4.40	251.0	256.0	263.5	268.5	276.0	283.5	288.5	296.0	303.5	310.9
4.45	255.0	260.1	267.7	272.8	280.4	288.0	293.1	300.7	308.3	315.9
4.50	259.0	264.1	271.9	277.0	284.7	292.5	297.6	305.4	313.1	320.8
4.55	262.9	268.2	276.0	281.3	289.1	297.0	302.2	310.1	317.9	325.7
4.60	266.9	272.2	280.2	285.5	293.5	301.5	306.8	314.8	322.7	330.7
4.65	270.9	276.3	284.4	289.8	297.9	306.0	311.4	319.5	327.5	335.6
4.70	274.9	280.4	288.6	294.1	302.3	310.5	315.9	324.2	332.4	340.6
4.75	278.9	284.4	292.8	298.3	306.7	315.0	320.5	328.8	337.2	345.5
4.80	282.9	288.5	297.0	302.6	311.0	319.5	325.1	333.5	342.0	350.4
4.85	286.9	292.6	301.1	306.8	315.4	324.0	329.7	338.2	346.8	355.4
4.90	290.8	296.6	305.3	311.1	319.8	328.5	334.3	342.9	351.6	360.3
4.95	294.8	300.7	309.5	315.4	324.2	333.0	338.8	347.6	356.4	365.2
5.00	298.8	304.8	313.7	319.6	328.6	337.5	343.4	352.3	361.3	370.2



■ Tape and Reel Dimension

TO-252-2

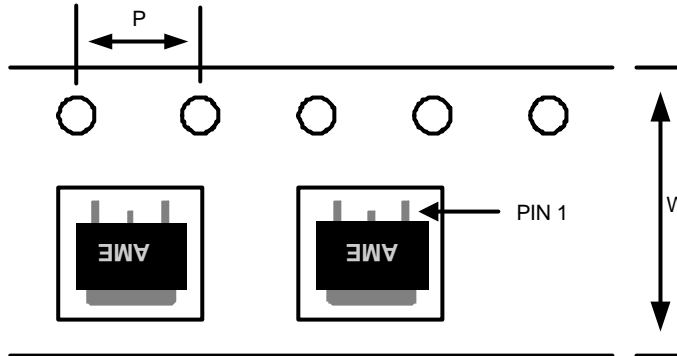

Carrier Tape, Number of Components Per Reel and Reel Size

Package	Carrier Width (W)	Pitch (P)	Part Per Full Reel	Reel Size
TO-252-2	16.0±0.1 mm	4.0±0.1 mm	2500pcs	330±1 mm

TO-252-3

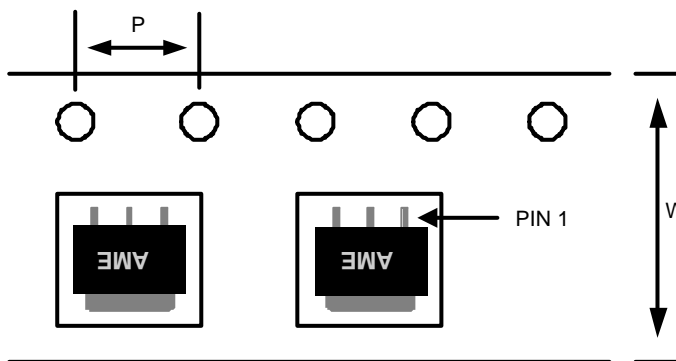

Carrier Tape, Number of Components Per Reel and Reel Size

Package	Carrier Width (W)	Pitch (P)	Part Per Full Reel	Reel Size
TO-252-3	16.0±0.1 mm	4.0±0.1 mm	2500pcs	330±1 mm

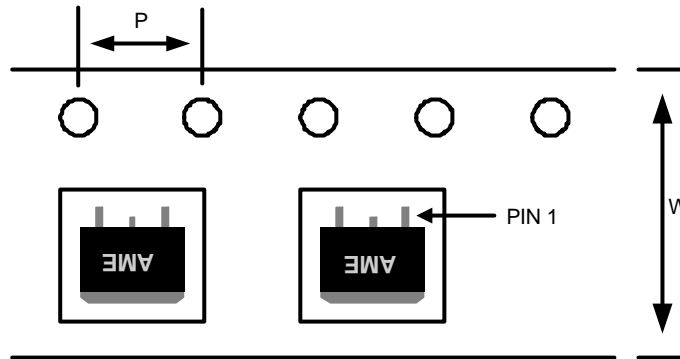
■ Tape and Reel Dimension
TO-263-2

Carrier Tape, Number of Components Per Reel and Reel Size

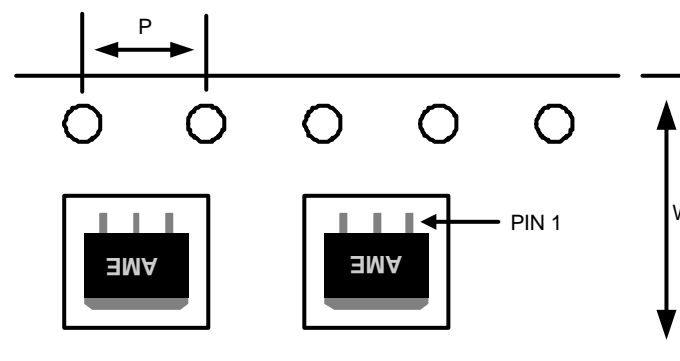
Package	Carrier Width (W)	Pitch (P)	Part Per Full Reel	Reel Size
TO-263-2	24.0±0.1 mm	4.0±0.1 mm	800pcs	330±1 mm

TO-263-3

Carrier Tape, Number of Components Per Reel and Reel Size

Package	Carrier Width (W)	Pitch (P)	Part Per Full Reel	Reel Size
TO-263-3	24.0±0.1 mm	4.0±0.1 mm	800pcs	330±1 mm

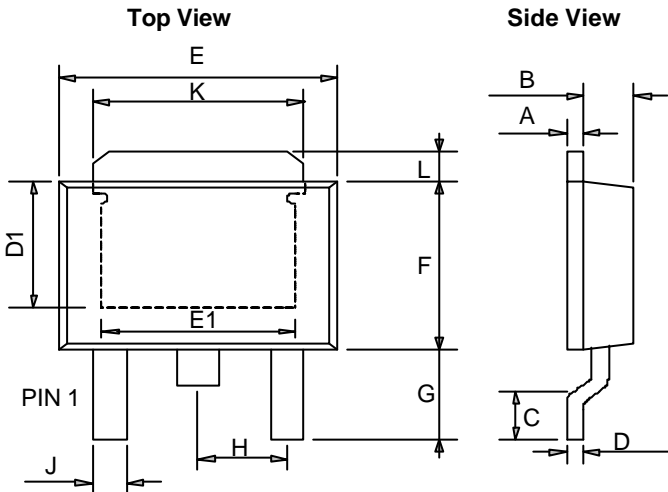

■ Package Dimension

TO-252-2



SYMBOLS	MILLIMETERS		INCHES	
	MIN	MAX	MIN	MAX
A	0.43	0.58	0.0169	0.0230
B	1.60	1.95	0.0630	0.0768
C	0.51	1.78	0.0200	0.0701
D	0.43	0.60	0.0169	0.0236
E	6.35	6.80	0.2500	0.2677
F	5.36	7.20	0.2110	0.2835
G	2.20	3.00	0.0866	0.1181
H	-	* 2.30	-	*0.0906
J	-	0.97	-	0.0380
K	5.20	5.50	0.2047	0.2165
L	1.40 REF		0.0551 REF	
D1	3.80 REF		0.1496 REF	
E1	3.81	5.10	0.1500	0.2008

*: Typical Value

Notes:

1. Controlling dimension: Millimeters.

2. Maximum lead thickness includes lead finish thickness. Minimum lead thickness is the minimum thickness of base material.

TO-220-3

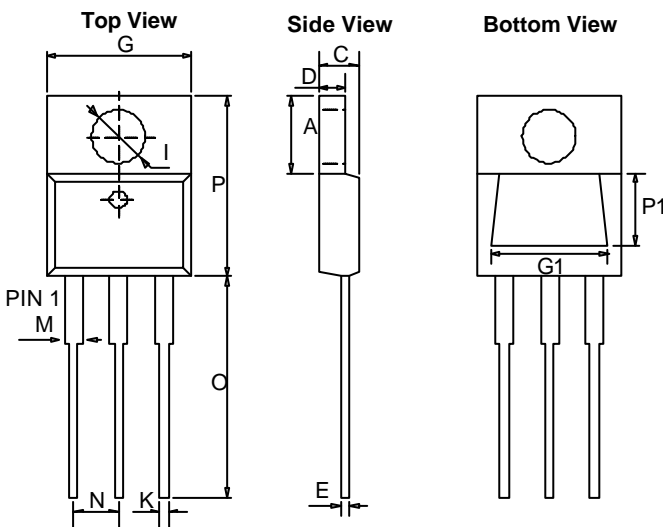

SYMBOLS	MILLIMETERS		INCHES	
	MIN	MAX	MIN	MAX
A	5.58	7.49	0.2197	0.2949
C	2.03	4.83	0.0799	0.1902
D	0.50	1.40	0.0197	0.0551
E	0.30	1.15	0.0118	0.0453
G	9.65	10.67	0.3799	0.4201
I	3.53	4.09	0.1390	0.1610
K	0.50	1.15	0.0197	0.0453
M	1.14	1.78	0.0449	0.0701
N	2.28	2.80	0.0898	0.1102
O	12.70	14.74	0.5000	0.5803
P	14.22	16.51	0.5598	0.6500
P1	5.00	5.70	0.1969	0.2244
G1	7.30	8.05	0.2874	0.3169

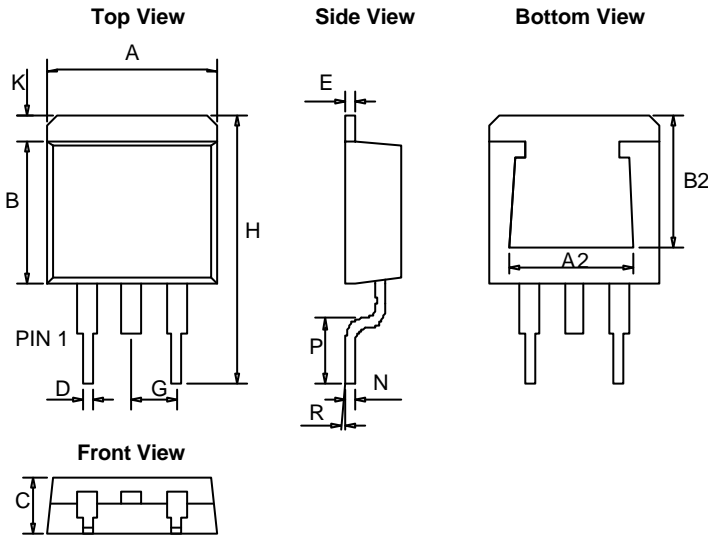
■ Package Dimension
TO-263-2

SYMBOLS	MILLIMETERS		INCHES	
	MIN	MAX	MIN	MAX
A	9.65	10.42	0.380	0.410
B	8.28	9.66	0.326	0.380
C	4.06	4.83	0.160	0.190
D	0.50	1.36	0.020	0.054
E	1.14	1.45	0.045	0.057
G	*2.54		*0.100	
H	14.60	15.60	0.5748	0.61417
K	0.99	2.93	0.03898	0.11535
N	0.381 REF		0.015 REF	
P	2.28	2.80	0.08976	0.11024
R	0°	8°	0°	8°
B2	6.30	8.20	0.248	0.323
A2	7.30	8.95	0.287	0.352

*: Typical Value

Notes:

1. Controlling dimension: Millimeters.
2. Maximum lead thickness includes lead finish thickness Minimum lead thickness is the minimum thickness of base material.

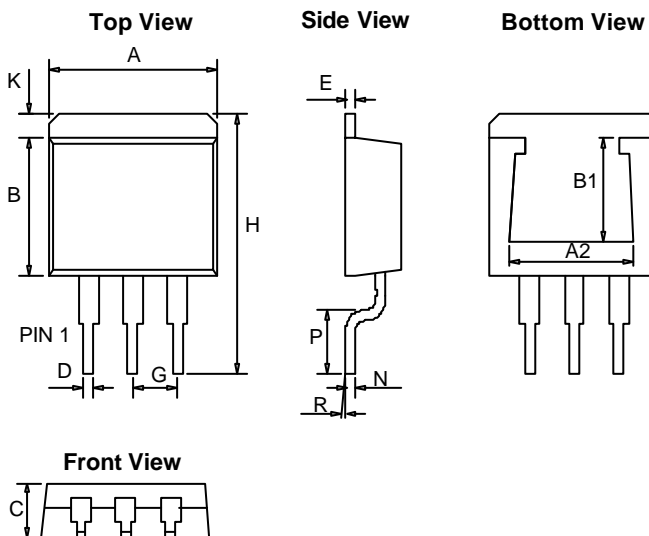
TO-263-3

SYMBOLS	MILLIMETERS		INCHES	
	MIN	MAX	MIN	MAX
A	9.65	10.67	0.380	0.420
B	8.28	9.66	0.326	0.380
C	4.06	4.83	0.160	0.190
D	0.50	1.36	0.020	0.054
E	1.14	1.45	0.045	0.057
G	*2.54		*0.100	
H	14.60	15.875	0.5748	0.625
K	0.99	2.93	0.03898	0.11535
N	0.31		0.012	
P	2.28	2.80	0.08976	0.11024
R	0°	8°	0°	8°
B1	5.00	5.70	0.197	0.224
A2	7.30	8.05	0.287	0.317

*: Typical Value

Notes:

1. Controlling dimension: Millimeters.
2. Maximum lead thickness includes lead finish thickness Minimum lead thickness is the minimum thickness of base material.



www.ame.com.tw
E-Mail: sales@ame.com.tw

Life Support Policy:

These products of AME, Inc. are not authorized for use as critical components in life-support devices or systems, without the express written approval of the president of AME, Inc.

AME, Inc. reserves the right to make changes in the circuitry and specifications of its devices and advises its customers to obtain the latest version of relevant information.

© AME, Inc. , June 2008

Document: 1012-DS1084-N.03

Corporate Headquarter

AME, Inc.

2F, 302 Rui-Guang Road, Nei-Hu District
Taipei 114, Taiwan.

Tel: 886 2 2627-8687

Fax: 886 2 2659-2989