

23V, 3A, 380KHz Asynchronous Step-Down DC/DC Converter

Description

The FR9723B is a 380KHz step-down DC/DC converter that provides wide 4.75V to 23V input voltage range and 3A continuous load current capability.

Fault protection includes cycle-by-cycle current limit, input UVLO and thermal shutdown. Besides, adjustable soft-start function prevents inrush current at turn-on. This device uses current mode control scheme that provides fast transient response. In shutdown mode, the supply current is about 10µA.

The FR9723B is available in an 8-pin SOIC package, which provides a very compact system solution and good thermal conductance.

Features

- Wide Input Voltage from 4.75V to 23V
- 3A Output Current
- Adjustable Output Voltage from 1.23V to 20V
- 100mΩ Integrated Power MOSFET
- High Efficiency up to 90%
- Fixed 380KHz Switching Frequency
- Current Mode Operation
- Adjustable Soft-Start
- Cycle-by-Cycle Current Limit
- Input Under Voltage Lockout
- Over-Temperature Protection with Auto Recovery
- 10µA Shutdown Current
- Thermal Enhanced SOP-8 (Exposed Pad) Package
- RoHS Compliant

Applications

- Set-Top-Box
- DVD, LCD Display
- OLPC, Netbook
- Distributed Power System
- DSL Modem

Pin Assignments

SP Package (SOP-8 Exposed Pad)

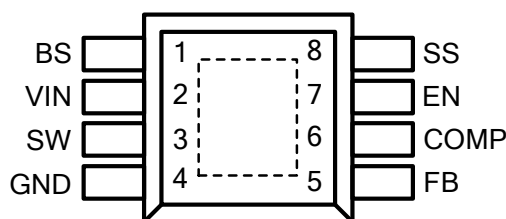
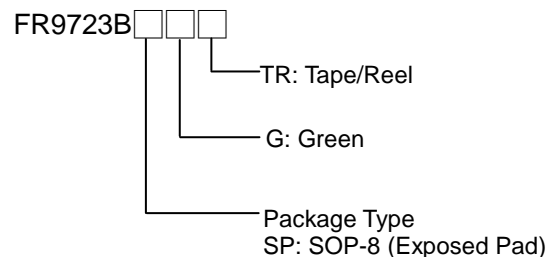

Figure 1. Pin Assignment of FR9723B

Ordering Information



Typical Application Circuit

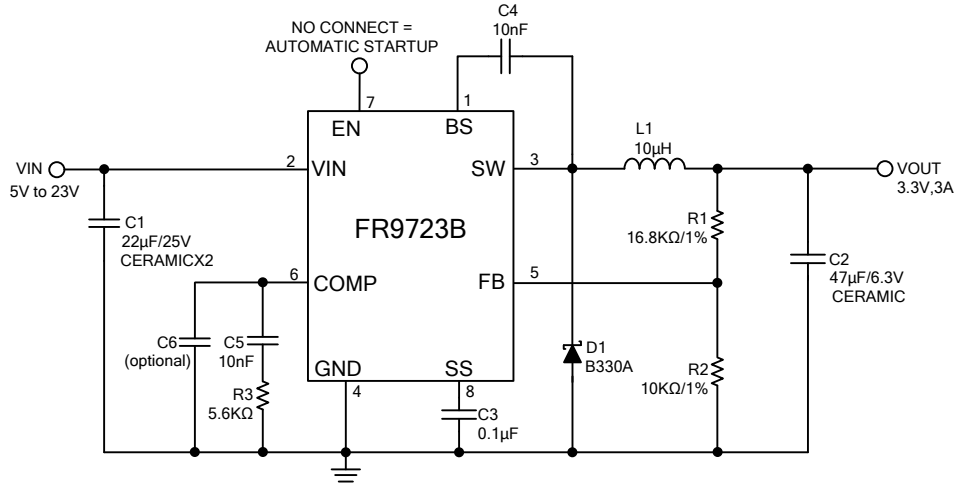

Figure 2. Output 3.3V Application Circuit

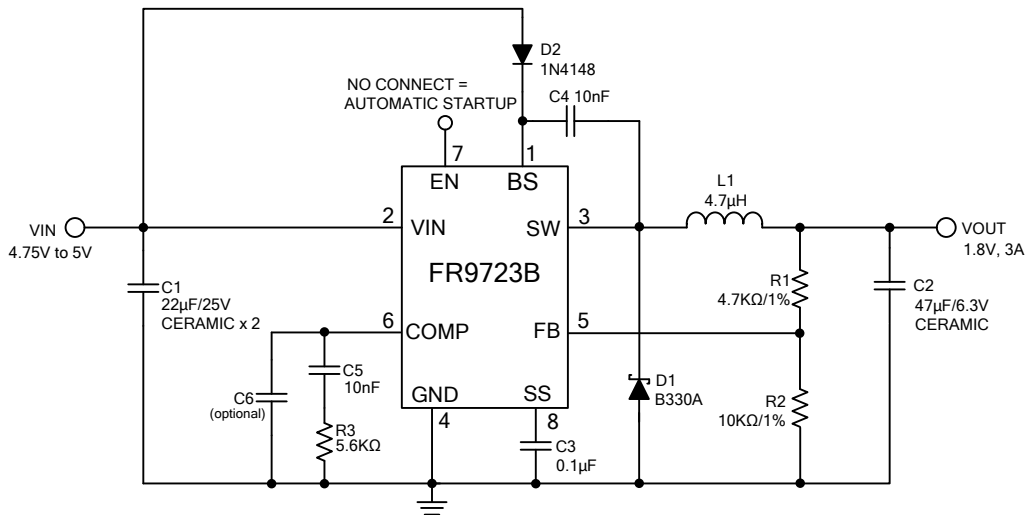

Figure 3. Low Input Voltage Application Circuit

Functional Pin Description

Pin Name	Pin Function
BS	High Side Gate Drive Boost Input. A 10nF or greater capacitor must be connected from this pin to SW. It can boost the gate drive to fully turn on the internal high side NMOS.
VIN	Power Supply Input Pin. Drive 4.75V to 23V voltage to this pin to power on this chip. Connect two 22μF ceramic bypass capacitors between VIN and GND to eliminate noise.
SW	Power Switching Output. It is the output pin of internal high side NMOS which is the switch to supply power.
GND	Ground Pin. Connect this pin to exposed pad.
FB	Voltage Feedback Input Pin. Connect FB and VOUT with a resistive voltage divider. This IC senses feedback voltage via FB and regulates it at 1.23V.
COMP	Compensation Pin. This pin is used to compensate the regulation control loop. Connect a series RC network from COMP pin to GND.
EN	Enable Input Pin. This pin provides a digital control to turn the converter on or off. For automatic startup, leave EN unconnected.
SS	Soft-Start Input Pin. This pin controls the soft-start period. Connect a capacitor from SS to GND to set the soft start period.

Block Diagram

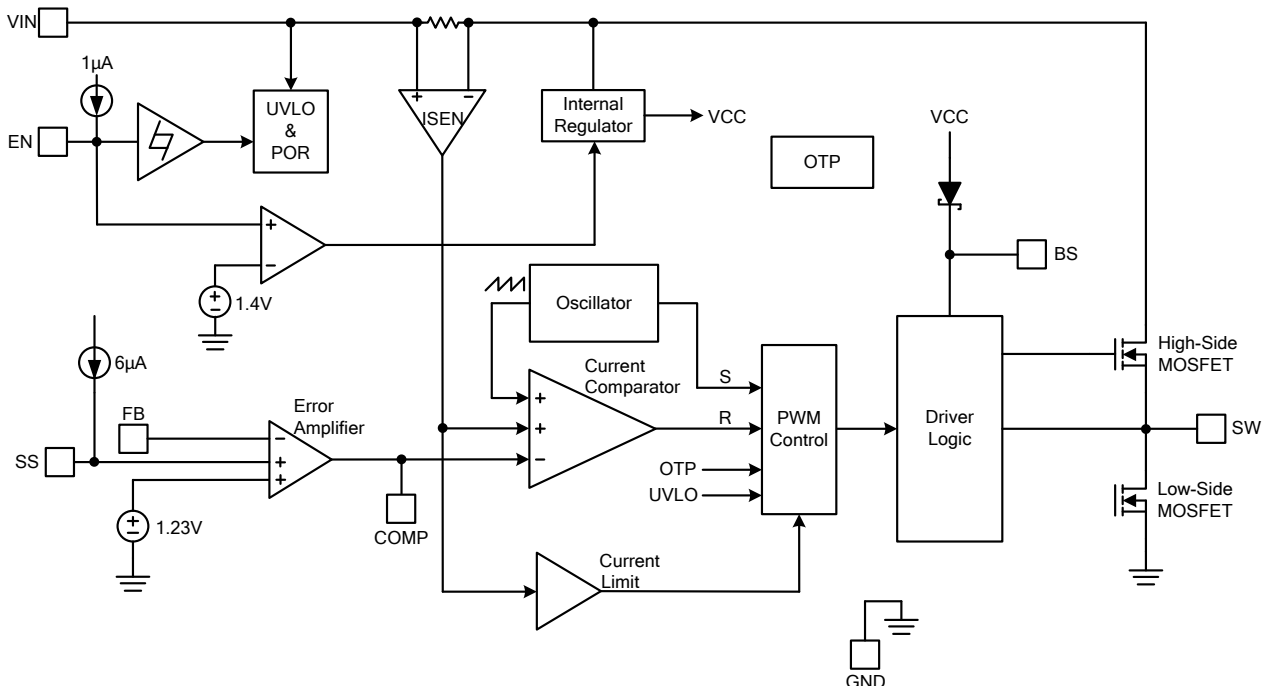

Figure 4. Block Diagram of FR9723B

Absolute Maximum Ratings

- Input Supply Voltage V_{IN} ----- -0.3V to +25V
- SW Voltage V_{SW} ----- -1V to $V_{IN} + 0.3V$
- BS Voltage V_{BS} ----- $V_{sw} - 0.3V$ to $V_{sw} + 6V$
- All Other Pins Voltage ----- -0.3V to +6V
- Maximum Junction Temperature (T_J) ----- +150°C
- Storage Temperature (T_S) ----- -65°C to +150°C
- Lead Temperature (Soldering, 10sec.) ----- +260°C
- Power Dissipation @ $T_A=25^\circ C$, (P_D)
 - SOP-8 (Exposed Pad) ----- 2.08W
- Package Thermal Resistance, (θ_{JA})
 - SOP-8 (Exposed Pad) ----- 60°C/W
- Package Thermal Resistance, (θ_{JC})
 - SOP-8 (Exposed Pad) ----- 15°C/W

Note 1 : Stresses beyond those listed under "Absolute Maximum Ratings" may cause permanent damage to the device.

Recommended Operating Conditions

- Input Supply Voltage (V_{IN}) ----- +4.75V to +23V
- Output Voltage (V_{OUT}) ----- +1.23V to +20V
- Operation Temperature Range ----- -40°C to +85°C

Electrical Characteristics

($V_{IN}=12V$, $T_A=25^{\circ}C$, unless otherwise specified.)

Parameter	Conditions	Min	Typ	Max	Unit
V_{IN} Input Supply Voltage		4.75		23	V
V_{IN} Supply Current	$V_{EN} = 1.8V$		1.5		mA
V_{IN} Shutdown Supply Current	$V_{EN} = 0V$		10		μA
Feedback Voltage	$4.75V \leq V_{IN} \leq 23V$	1.2	1.23	1.26	V
High-Side MOSFET $R_{DS(ON)}$ (Note2)			100		m Ω
Low-Side MOSFET $R_{DS(ON)}$ (Note2)			10		Ω
High-Side MOSFET Leakage Current	$V_{EN} = 0V$, $V_{SW} = 0V$			10	μA
High-Side MOSFET Current Limit (Note2)	Minimum Duty		5		A
Current sense to COMP Transconductance (Note2)			6.1		A/V
Error Amplifier Transconductance (Note2)	$\Delta I_{COMP} = \pm 10\mu A$		1800		$\mu A/V$
Error Amplifier Voltage Gain (Note2)			400		V/V
Oscillation frequency			380		KHz
Short Circuit Oscillation Frequency	$V_{FB} = 0V$		110		KHz
Maximum Duty Cycle	$V_{FB} = 1.0V$		90		%
Minimum On Time (Note2)			220		ns
Input UVLO Threshold	V_{IN} Rising		4.4		V
Under Voltage Lockout Threshold Hysteresis			400		mV
Soft-Start Current	$V_{COMP} = 0V$, $V_{SS} = 0V$		6		μA
Soft-Start Period	$C_{SS} = 0.1\mu F$		15		ms
EN Lockout Threshold Voltage		2.3	2.5	2.7	V
EN Shutdown Threshold Voltage		1.1	1.4		V
Thermal Shutdown Threshold (Note2)			160		$^{\circ}C$

Note 2 : Not production tested.

Typical Performance Curves

$V_{IN} = 12V$, $V_{OUT} = 3.3V$, $C1 = 22\mu F \times 2$, $C2 = 47\mu F \times 1$, $L1 = 10\mu H$, $T_A = +25^\circ C$, unless otherwise noted.

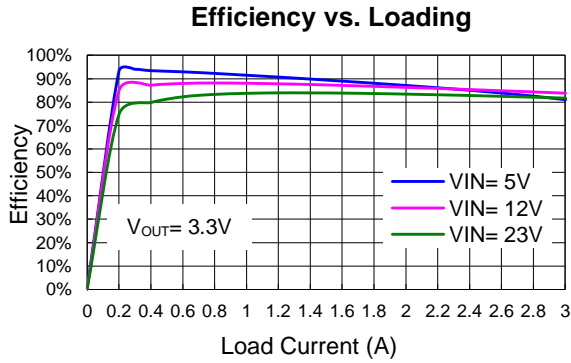

Figure 5. Efficiency vs. Loading

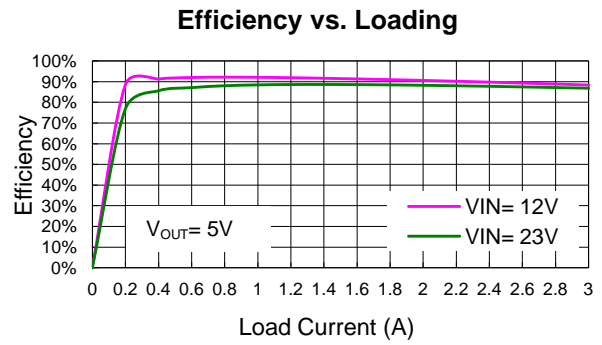

Figure 6. Efficiency vs. Loading

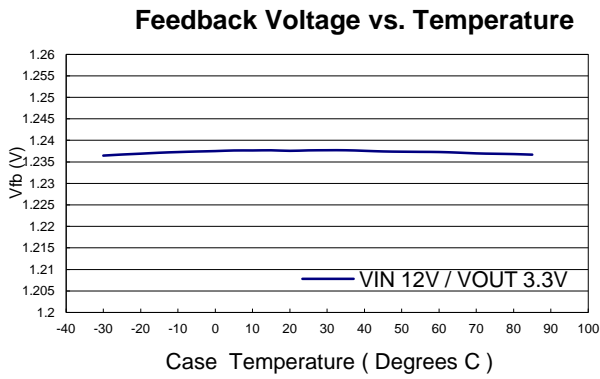

Figure 7. Feedback Voltage vs. Temperature

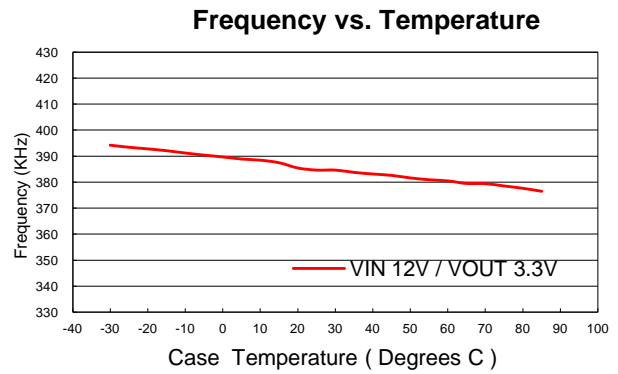

Figure 8. Frequency vs. Temperature

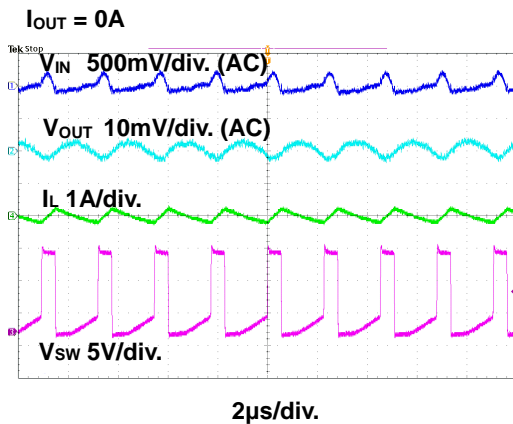

Figure 9. DC Ripple Waveform

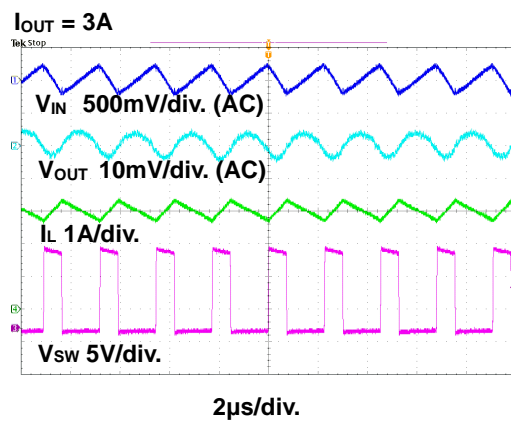
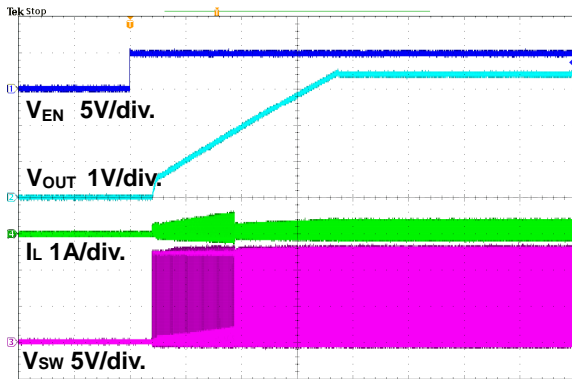

Figure 10. DC Ripple Waveform

Typical Performance Curves (Continued)

$V_{IN} = 12V$, $V_{OUT} = 3.3V$, $C1 = 22\mu F \times 2$, $C2 = 47\mu F \times 1$, $L1 = 10\mu H$, $T_A = +25^\circ C$, $T_A = +25^\circ C$, unless otherwise noted.

$I_{OUT} = 0.1A$



4ms/div.

Figure 11. Startup Through Enable Waveform

$I_{OUT} = 3A$

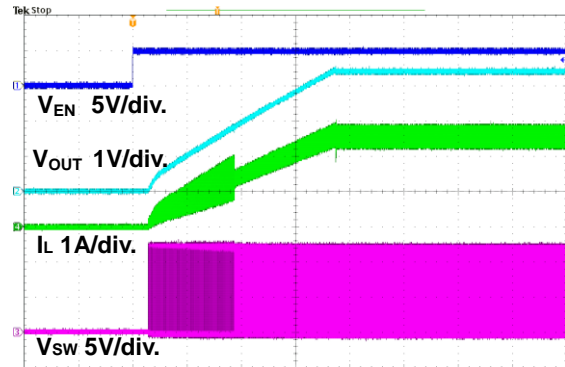

4ms/div.

Figure 12. Startup Through Enable Waveform

$I_{OUT} = 0.1A$

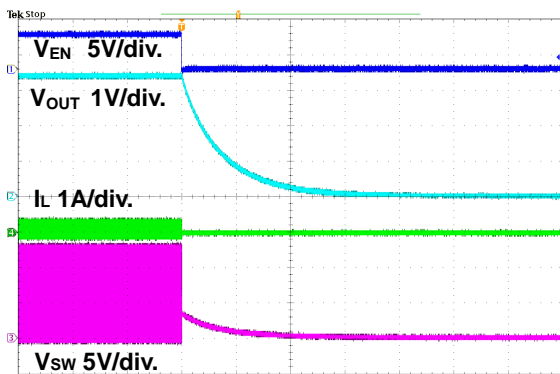

2ms/div.

Figure 13. Turn off Through Enable Waveform

$I_{OUT} = 3A$

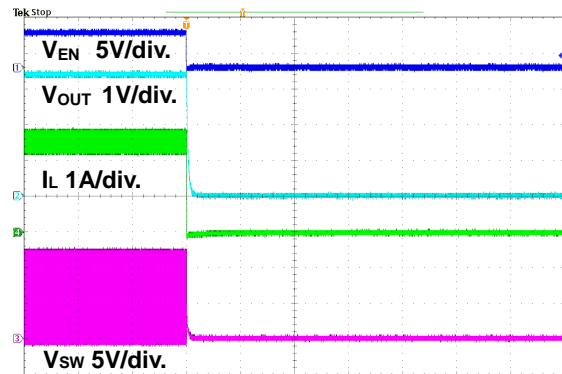

2ms/div.

Figure 14. Turn off Through Enable Waveform

$I_{OUT} = 100mA \text{ to } 3A \text{ step}$

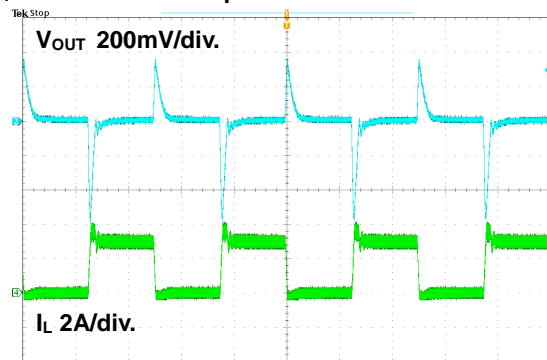

200µs/div.

Figure 15. Load Transient Waveform

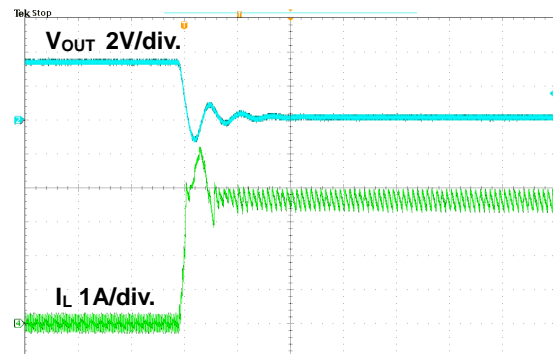

80µs/div.

Figure 16. Short Circuit Test Waveform

Function Description

The FR9723B is a constant frequency current mode step-down asynchronous DC/DC converter. It regulates input voltage from 4.75V to 23V, down to an output voltage as low as 1.23V, and can provide 3A of continuous load current.

Control Loop

During normal operation, the output voltage is sensed at FB pin by a resistive voltage divider and amplified through the error amplifier. The voltage of error amplifier output pin – COMP is compared to the switch current to controls the RS latch. At each cycle, the high side NMOS will be turned on when the oscillator sets the RS latch and turned off when current comparator resets the RS latch. When the load current increases, the FB pin voltage will drop below 1.22V, and it will cause the COMP voltage increasing until average inductor current arrives at new load current.

Enable

The FR9723B EN pin provides digital control to turn on/off the regulator. When the voltage of EN exceeds the threshold voltage, the regulator will start the soft start function. If the EN pin voltage is lower than threshold voltage, only the bandgap voltage will be alive. If the EN pin voltage is lower than shutdown threshold voltage, the regulator will be disabled and turn into shutdown mode.

Input Under Voltage Lockout

When the FR9723B is power on, the internal circuits will be held inactive until V_{IN} exceeds the input UVLO threshold voltage. And the regulator will be disabled when V_{IN} is below the input UVLO threshold voltage. The hysteresis of the UVLO comparator is 400 mV.

Short Circuit Protection

The FR9723B provides short circuit protection function to prevent the device damaged from short condition. When the output is short to ground, the oscillator frequency will be reduced to prevent the inductor current increasing beyond the current limit. In the meantime, the current limit will also be reduced to lower the short current. Once the short condition is removed, the frequency and current limit will return to normal.

Over Temperature Protection

The FR9723B incorporates an over temperature protection circuit to protect itself from overheating. When the junction temperature exceeds the thermal shutdown threshold temperature, the regulator will be shut down and re-enabled when the IC junction temperature drops 10°C (typ).

Compensation

The stability of the feedback circuit is controlled by COMP pin. The compensation value of the application circuit is optimized for particular requirements. If different conversions are required, some of the components may need to be changed to ensure stability.

Application Information

Output Voltage Setting

The output voltage V_{OUT} is set by using a resistive divider from the output to FB. The FB pin regulated voltage is 1.23V. Thus the output voltage is:

$$V_{OUT} = 1.23 \times \left(1 + \frac{R1}{R2} \right) V$$

R2 recommended value is 10k Ω , so R1 is determined by:

$$R1 = 8.13 \times (V_{OUT} - 1.23) k\Omega$$

Table 1 lists recommended values of R1 and R2 for most used output voltage.

Table 1 Recommended Resistance Values

V_{OUT}	R1	R2
5V	68 k Ω	22k Ω
3.3V	16.8k Ω	10 k Ω
1.8V	4.7 k Ω	10 k Ω
1.23V	4.7 k Ω	NC

Place resistors R1 and R2 close to FB pin to prevent stray pickup.

Input Capacitor Selection

The use of the input capacitor is controlling the input voltage ripple and the MOSFETS switching spike voltage. Because the input current to the step-down converter is discontinuous, the input capacitor is required to supply the current to the converter to keep the DC input voltage. The capacitor voltage rating should be 1.25 to 1.5 times greater than the maximum input voltage. The input capacitor ripple current RMS value is calculated as:

$$I_{IN(RMS)} = I_{OUT} \times \sqrt{D \times (1-D)}$$

$$D = \frac{V_{OUT}}{V_{IN}}$$

Where D is the duty cycle of the power MOSFET.

A low ESR capacitor is required to keep the noise minimum. Ceramic capacitors are better, but tantalum or low ESR electrolytic capacitors may also suffice. When using tantalum or electrolytic capacitors, a 0.1 μ F ceramic capacitor should be placed as close to the IC as possible.

Output Capacitor Selection

The output capacitor is used to keep the DC output voltage and supply the load transient current. When operating in constant current mode, the output ripple is determined by four components:

$$V_{RIPPLE}(t) = V_{RIPPLE(C)}(t) + V_{RIPPLE(ESR)}(t) + V_{RIPPLE(ESL)}(t) + V_{NOISE}(t)$$

The following figures show the form of the ripple contributions.

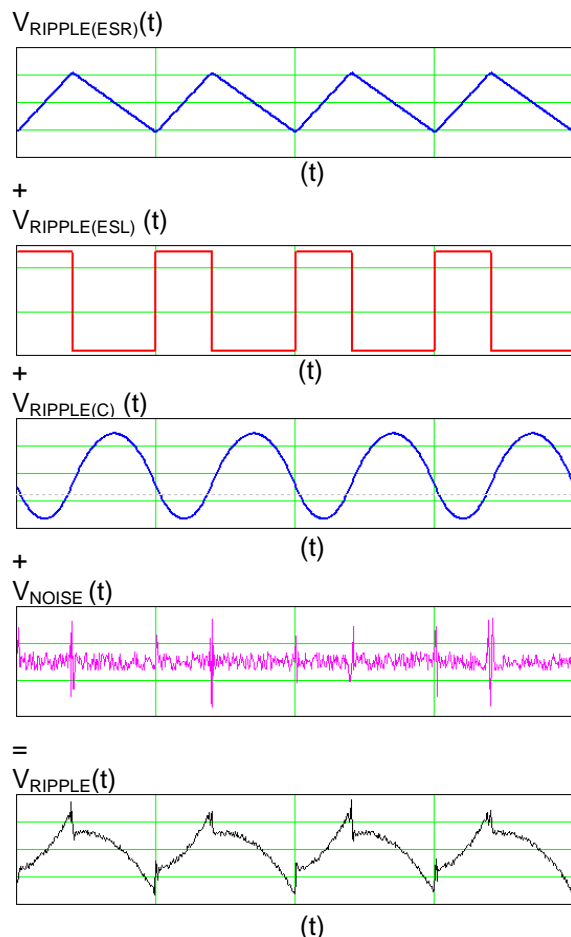

$$V_{RIPPLE(ESR, p-p)} = \frac{V_{OUT}}{F_{OSC} \times L} \times \left(1 - \frac{V_{OUT}}{V_{IN}} \right) \times ESR$$

$$V_{RIPPLE(ESL, p-p)} = \frac{ESL}{L + ESL} \times V_{IN}$$

$$V_{RIPPLE(C, p-p)} = \frac{V_{OUT}}{8 \times F_{OSC}^2 \times L \times C_{OUT}} \times \left(1 - \frac{V_{OUT}}{V_{IN}} \right)$$

Application Information (Continued)

Where F_{OSC} is the switching frequency, L is the inductance value, V_{IN} is the input voltage, ESR is the equivalent series resistance value of the output capacitor, ESL is the equivalent series inductance value of the output capacitor and the C_{OUT} is the output capacitor.

Low ESR capacitors are preferred to use. Ceramic, tantalum or low ESR electrolytic capacitors can be used depending on the output ripple requirements. When using the ceramic capacitors, the ESL component is usually negligible.

It is important to use the proper method to eliminate high frequency noise when measuring the output ripple. The figure shows how to locate the probe across the capacitor when measuring output ripple. Remove the scope probe plastic jacket in order to expose the ground at the tip of the probe. It gives a very short connection from the probe ground to the capacitor and eliminates noise.

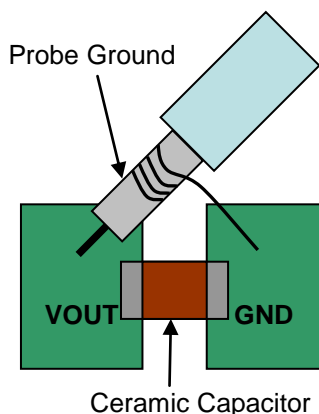

Output Inductor Selection

The output inductor is used for storing energy and filtering output ripple current. But the trade-off condition often happens between maximum energy storage and the physical size of the inductor. The first consideration for selecting the output inductor is to make sure that the inductance is large enough to keep the converter in the continuous current mode. That will lower ripple current and result in lower output ripple voltage. A good rule for determining the inductance is setting the peak-to-peak inductor ripple current ΔI almost equal to 30% of the maximum load current. Then the minimum inductance can be calculated with the following equation:

$$\Delta I = 0.3 \times I_{OUT(MAX)}$$

$$L \geq (V_{IN} - V_{OUT}) \times \left(\frac{V_{OUT}}{F_{OSC} \times \Delta I \times V_{IN}} \right)$$

Where V_{IN} is the maximum input voltage.

Compensation Components Selection

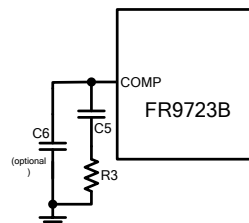

Select appropriate compensation value by following procedure:

1. Calculate the $R3$ value with the following equation:

$$R3 < \frac{2\pi \times C_{OUT} \times 0.1 \times F_{OSC} \times V_{OUT}}{G_{EA} \times G_{CS} \times V_{REF}}$$

where G_{EA} is the error amplifier voltage gain, and G_{CS} is the current sense gain.

2. Calculate the $C5$ value with the following equation:

$$C5 > \frac{4}{2\pi \times R3 \times 0.1 \times F_{OSC}}$$

3. If the C_{OUT} ESR zero is less than half of the switching frequency, use $C6$ to cancel the ESR zero:

$$C6 = \frac{C_{OUT} \times R_{ESR}}{R3}$$

External Boost Diode Selection

For 5V input applications, it is recommended that an external boost diode could be added. This helps improving the efficiency. The boost diode can be a low cost one such as 1N4148.

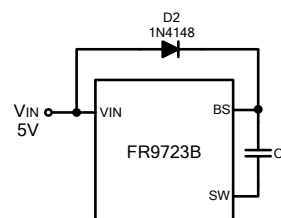

Application Information (Continued)

PCB Layout Recommendation

The device's performance and stability are dramatically affected by PCB layout. It is recommended to follow these general guidelines shown as below:

1. Place the input capacitors and output capacitors as close to the device as possible. The traces which connect to these capacitors should be as short and wide as possible to minimize parasitic inductance and resistance.
2. Place V_{IN} bypass capacitors close to the V_{IN} pin.
3. Place feedback resistors close to the FB pin.
4. Place compensation components close to the COMP pin.
5. Keep the sensitive signal (FB, COMP) away from the switching signal (SW).
6. The exposed pad of the package should be soldered to an equivalent area of metal on the PCB. This area should connect to the GND plane and have multiple via connections to the back of the PCB as well as connections to intermediate PCB layers. The GND plane area which connects to the exposed pad should be maximized to improve thermal performance.
7. Multi-layer PCB design is recommended.

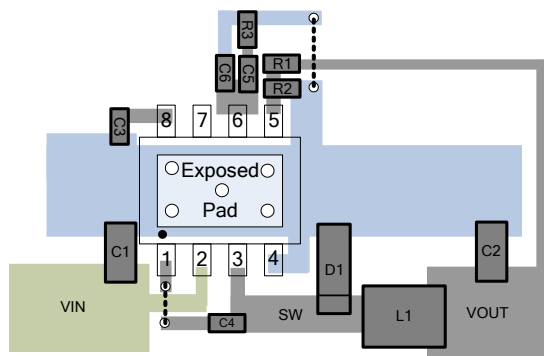
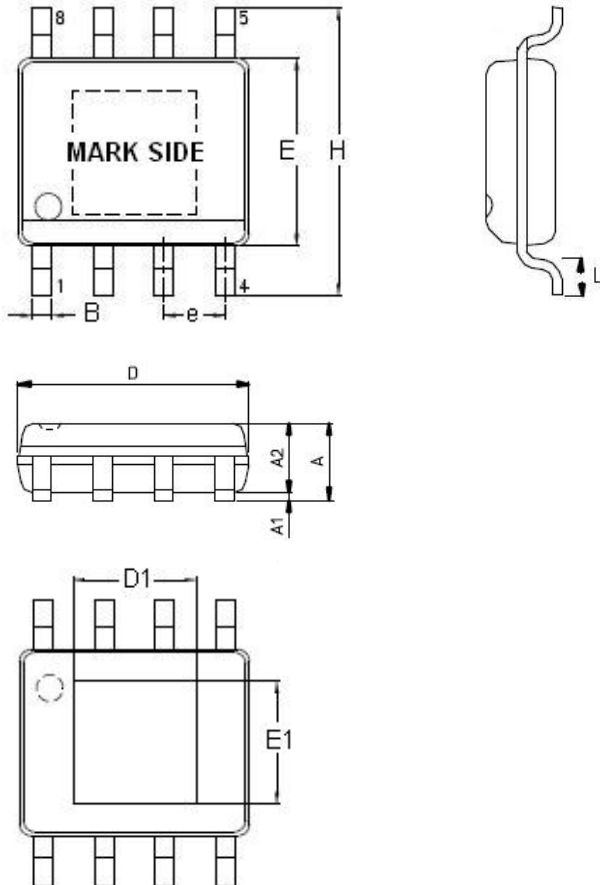

Figure 17. Recommended Layout Diagram

Outline Information

SOP-8 (Exposed Pad) Package (Unit: mm)



SYMBOLS UNIT	DIMENSION IN MILLIMETER	
	MIN	MAX
A	1.25	1.70
A1	0.00	0.15
A2	1.25	1.55
B	0.31	0.51
D	4.80	5.00
D1	3.04	3.50
E	3.80	4.00
E1	2.15	2.41
e	1.20	1.34
H	5.80	6.20
L	0.40	1.27

Note : Followed From JEDEC MO-012-E.

Carrier dimensions

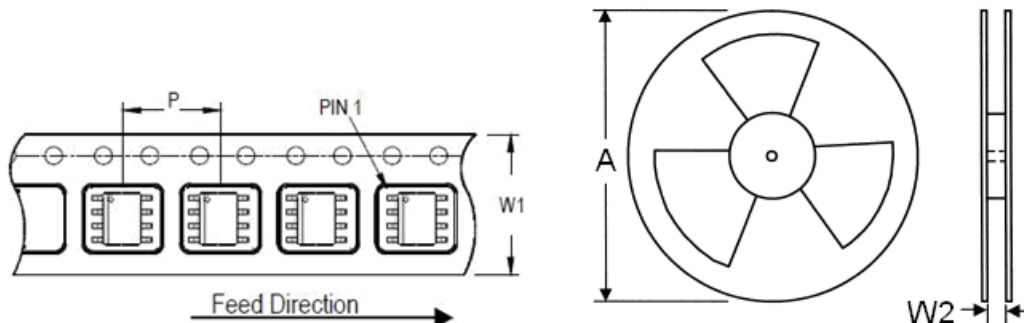

Tape Size (W1) mm	Pocket Pitch (P) mm	Reel Size (A)		Reel Width (W2) mm	Empty Cavity Length mm	Units per Reel
		in	mm			
12	8	13	330	12.4	400~1000	2,500

Life Support Policy

Fitipower's products are not authorized for use as critical components in life support devices or other medical systems.