

TOSHIBA BIPOLAR LINEAR INTEGRATED CIRCUIT SILICON MONOLITHIC

**TA79005S, TA79006S, TA79007S, TA79008S, TA79009S, TA79010S
TA79012S, TA79015S, TA79018S, TA79020S, TA79024S**

1A THREE TERMINAL NEGATIVE VOLTAGE REGULATORS

**- 5V, - 6V, - 7V, - 8V, - 9V, - 10V, - 12V, - 15V, - 18V, - 20V,
- 24V**

FEATURES

- Suitable for CMOS, TTL, and the other Digital IC Power Supply
- Internal Thermal Overload Protecting
- Internal Short Circuit Current Limiting
- Output Current in Excess of 1.0A
- Metal Fin (Tab) is fully covered with Mold Resin.
(TO-220 NIS package)

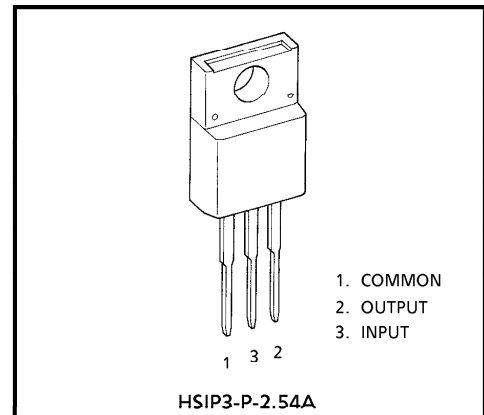

Weight : 1.7g (Typ.)

EQUIVALENT CIRCUIT

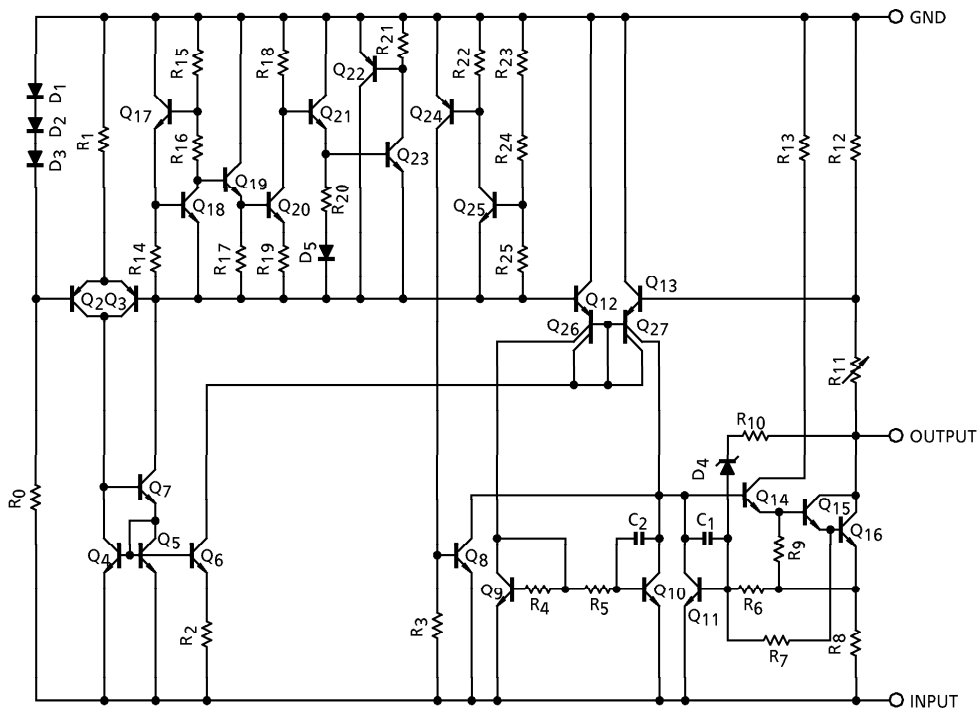

961001EBA2

● TOSHIBA is continually working to improve the quality and the reliability of its products. Nevertheless, semiconductor devices in general can malfunction or fail due to their inherent electrical sensitivity and vulnerability to physical stress. It is the responsibility of the buyer, when utilizing TOSHIBA products, to observe standards of safety, and to avoid situations in which a malfunction or failure of a TOSHIBA product could cause loss of human life, bodily injury or damage to property. In developing your designs, please ensure that TOSHIBA products are used within specified operating ranges as set forth in the most recent products specifications. Also, please keep in mind the precautions and conditions set forth in the TOSHIBA Semiconductor Reliability Handbook.

MAXIMUM RATINGS (Ta = 25°C)

CHARACTERISTIC		SYMBOL	RATING	UNIT
Input Voltage	TA79005S	V _{IN}	- 35	V
	TA79006S			
	TA79007S			
	TA79008S			
	TA79009S			
	TA79010S			
	TA79012S			
	TA79015S		- 40	
	TA79018S			
	TA79020S			
	TA79024S			
Power Dissipation	(Ta = 25°C)	P _D	2	W
	(Tc = 25°C)		20	
Operating Temperature		T _{opr}	- 30~75	°C
Storage Temperature		T _{stg}	- 55~150	°C
Operating Junction Temperature		T _j	- 30~150	°C
Thermal Resistance	R _{th(j-c)}		6.25	°C / W
	R _{th(j-a)}		62.5	

961001EBA2'

- The products described in this document are subject to foreign exchange and foreign trade control laws.
- The information contained herein is presented only as a guide for the applications of our products. No responsibility is assumed by TOSHIBA CORPORATION for any infringements of intellectual property or other rights of the third parties which may result from its use. No license is granted by implication or otherwise under any intellectual property or other rights of TOSHIBA CORPORATION or others.
- The information contained herein is subject to change without notice.

TA79005S

ELECTRICAL CHARACTERISTICS

(Unless otherwise specified, $V_{IN} = -10V$, $I_{OUT} = 500mA$, $0^{\circ}C \leq T_j \leq 125^{\circ}C$, $C_{IN} = 1.0\mu F$, $C_{OUT} = 1.0\mu F$)

CHARACTERISTIC	SYMBOL	TEST CIR-CUIT	TEST CONDITION	MIN.	TYP.	MAX.	UNIT	
Output Voltage	V_{OUT}	1	$T_j = 25^{\circ}C$	-5.2	-5.0	-4.8	V	
Line Regulation	Reg.Line	1	$T_j = 25^{\circ}C$	$-12V \leq V_{IN} \leq -8V$	—	7	50	mV
				$-25V \leq V_{IN} \leq -7V$	—	35	100	
Load Regulation	Reg.Load	1	$T_j = 25^{\circ}C$	$5mA \leq I_{OUT} \leq 1.5A$	—	11	100	mV
				$250mA \leq I_{OUT} \leq 750mA$	—	4	50	
Output Voltage	V_{OUT}	1	$T_j = 25^{\circ}C$	-5.25	—	-4.75	V	
Quiescent Current	I_B	1	$T_j = 25^{\circ}C$	—	4.3	8.0	mA	
Quiescent Current Change	Line	1	$-25V \leq V_{IN} \leq -7V$	—	—	1.3	mA	
	Load			$5mA \leq I_{OUT} \leq 1.0A$	—	—		0.5
Output Noise Voltage	V_{NO}	2	$T_a = 25^{\circ}C$, $10Hz \leq f \leq 100kHz$	—	40	—	μV_{rms}	
Ripple Rejection	R.R.	3	$f = 120Hz$, $I_{OUT} = 20mA$	63	70	—	dB	
Short Circuit Current Limit	I_{SC}	1	$T_j = 25^{\circ}C$	—	1.9	—	A	
Average Temperature Coefficient Of Output Voltage	T_{CVO}	1	$I_{OUT} = 5.0mA$	—	0.6	—	mV/ $^{\circ}C$	
Dropout Voltage	V_D	1	$T_j = 25^{\circ}C$, $I_{OUT} = 1.0A$	—	2.0	—	V	

TA79006S

ELECTRICAL CHARACTERISTICS

(Unless otherwise specified, $V_{IN} = -11V$, $I_{OUT} = 500mA$, $0^{\circ}C \leq T_j \leq 125^{\circ}C$, $C_{IN} = 1.0\mu F$, $C_{OUT} = 1.0\mu F$)

CHARACTERISTIC	SYMBOL	TEST CIR-CUIT	TEST CONDITION	MIN.	TYP.	MAX.	UNIT	
Output Voltage	V_{OUT}	1	$T_j = 25^{\circ}C$	-6.25	-6.0	-5.75	V	
Line Regulation	Reg.Line	1	$T_j = 25^{\circ}C$	$-13V \leq V_{IN} \leq -9V$	—	9	60	mV
				$-25V \leq V_{IN} \leq -8V$	—	43	120	
Load Regulation	Reg.Load	1	$T_j = 25^{\circ}C$	$5mA \leq I_{OUT} \leq 1.5A$	—	13	120	mV
				$250mA \leq I_{OUT} \leq 750mA$	—	5	60	
Output Voltage	V_{OUT}	1	$T_j = 25^{\circ}C$	-6.3	—	-5.7	V	
Quiescent Current	I_B	1	$T_j = 25^{\circ}C$	—	4.3	8.0	mA	
Quiescent Current Change	Line	1	$-25V \leq V_{IN} \leq -8V$	—	—	1.3	mA	
	Load							$5mA \leq I_{OUT} \leq 1.0A$
Output Noise Voltage	V_{NO}	2	$T_a = 25^{\circ}C$, $10Hz \leq f \leq 100kHz$	—	45	—	μV_{rms}	
Ripple Rejection	R.R.	3	$f = 120Hz$, $I_{OUT} = 20mA$	61	68	—	dB	
Short Circuit Current Limit	I_{SC}	1	$T_j = 25^{\circ}C$	—	1.9	—	A	
Average Temperature Coefficient Of Output Voltage	T_{CVO}	1	$I_{OUT} = 5.0mA$	—	0.7	—	$mV/^{\circ}C$	
Dropout Voltage	V_D	1	$T_j = 25^{\circ}C$, $I_{OUT} = 1.0A$	—	2.0	—	V	

TA79007S

ELECTRICAL CHARACTERISTICS

(Unless otherwise specified, $V_{IN} = -12V$, $I_{OUT} = 500mA$, $0^{\circ}C \leq T_j \leq 125^{\circ}C$, $C_{IN} = 1.0\mu F$, $C_{OUT} = 1.0\mu F$)

CHARACTERISTIC	SYMBOL	TEST CIR-CUIT	TEST CONDITION	MIN.	TYP.	MAX.	UNIT	
Output Voltage	V_{OUT}	1	$T_j = 25^{\circ}C$	-7.28	-7.0	-6.72	V	
Line Regulation	Reg.Line	1	$T_j = 25^{\circ}C$	$-15V \leq V_{IN} \leq -10V$	—	10	70	mV
				$-25V \leq V_{IN} \leq -9V$	—	45	140	
Load Regulation	Reg.Load	1	$T_j = 25^{\circ}C$	$5mA \leq I_{OUT} \leq 1.5A$	—	20	140	mV
				$250mA \leq I_{OUT} \leq 750mA$	—	7	70	
Output Voltage	V_{OUT}	1	$T_j = 25^{\circ}C$	-7.35	—	-6.65	V	
Quiescent Current	I_B	1	$T_j = 25^{\circ}C$	—	4.3	8.0	mA	
Quiescent Current Change	Line	1	$-25V \leq V_{IN} \leq -9V$	—	—	1.0	mA	
	Load							$5mA \leq I_{OUT} \leq 1.0A$
Output Noise Voltage	V_{NO}	2	$T_a = 25^{\circ}C$, $10Hz \leq f \leq 100kHz$	—	49	—	μV_{rms}	
Ripple Rejection	R.R.	3	$f = 120Hz$, $I_{OUT} = 20mA$	60	67	—	dB	
Short Circuit Current Limit	I_{SC}	1	$T_j = 25^{\circ}C$	—	1.9	—	A	
Average Temperature Coefficient Of Output Voltage	T_{CVO}	1	$I_{OUT} = 5.0mA$	—	0.9	—	$mV/^{\circ}C$	
Dropout Voltage	V_D	1	$T_j = 25^{\circ}C$, $I_{OUT} = 1.0A$	—	2.0	—	V	

TA79008S

ELECTRICAL CHARACTERISTICS

(Unless otherwise specified, $V_{IN} = -14V$, $I_{OUT} = 500mA$, $0^{\circ}C \leq T_j \leq 125^{\circ}C$, $C_{IN} = 1.0\mu F$, $C_{OUT} = 1.0\mu F$)

CHARACTERISTIC	SYMBOL	TEST CIR-CUIT	TEST CONDITION	MIN.	TYP.	MAX.	UNIT	
Output Voltage	V_{OUT}	1	$T_j = 25^{\circ}C$	-8.3	-8.0	-7.7	V	
Line Regulation	Reg.Line	1	$T_j = 25^{\circ}C$	$-17V \leq V_{IN} \leq -11V$	—	11	80	mV
				$-25V \leq V_{IN} \leq -10.5V$	—	47	160	
Load Regulation	Reg.Load	1	$T_j = 25^{\circ}C$	$5mA \leq I_{OUT} \leq 1.5A$	—	26	160	mV
				$250mA \leq I_{OUT} \leq 750mA$	—	9	80	
Output Voltage	V_{OUT}	1	$T_j = 25^{\circ}C$	-8.4	—	-7.6	V	
Quiescent Current			$T_j = 25^{\circ}C$	—	4.3	8.0	mA	
Quiescent Current Change	Line	ΔI_{BI}	1	$-25V \leq V_{IN} \leq -10.5V$	—	—	1.0	mA
	Load	ΔI_{BO}	1	$5mA \leq I_{OUT} \leq 1.0A$	—	—	0.5	
Output Noise Voltage	V_{NO}	2	$T_a = 25^{\circ}C$, $10Hz \leq f \leq 100kHz$	—	52	—	μV_{rms}	
Ripple Rejection	R.R.	3	$f = 120Hz$, $I_{OUT} = 20mA$	59	66	—	dB	
Short Circuit Current Limit	I_{SC}	1	$T_j = 25^{\circ}C$	—	1.9	—	A	
Average Temperature Coefficient Of Output Voltage	T_{CVO}	1	$I_{OUT} = 5.0mA$	—	1.0	—	$mV/^{\circ}C$	
Dropout Voltage	V_D	1	$T_j = 25^{\circ}C$, $I_{OUT} = 1.0A$	—	2.0	—	V	

TA79009S

ELECTRICAL CHARACTERISTICS

(Unless otherwise specified, $V_{IN} = -15V$, $I_{OUT} = 500mA$, $0^{\circ}C \leq T_j \leq 125^{\circ}C$, $C_{IN} = 1.0\mu F$, $C_{OUT} = 1.0\mu F$)

CHARACTERISTIC	SYMBOL	TEST CIR-CUIT	TEST CONDITION	MIN.	TYP.	MAX.	UNIT	
Output Voltage	V_{OUT}	1	$T_j = 25^{\circ}C$	-9.3	-9.0	-8.7	V	
Line Regulation	Reg.Line	1	$T_j = 25^{\circ}C$	$-19V \leq V_{IN} \leq -13V$	—	11	82	mV
				$-26V \leq V_{IN} \leq -11.5V$	—	48	162	
Load Regulation	Reg.Load	1	$T_j = 25^{\circ}C$	$5mA \leq I_{OUT} \leq 1.5A$	—	33	162	mV
				$250mA \leq I_{OUT} \leq 750mA$	—	11	82	
Output Voltage	V_{OUT}	1	$T_j = 25^{\circ}C$	-9.4	—	-8.6	V	
			$-24V \leq V_{IN} \leq -11.5V$ $5mA \leq I_{OUT} \leq 1.0A$					
Quiescent Current	I_B	1	$T_j = 25^{\circ}C$	—	4.3	8.0	mA	
Quiescent Current Change	Line	1	$-26.5V \leq V_{IN} \leq -13V$	—	—	1.0	mA	
	Load	1	$5mA \leq I_{OUT} \leq 1.0A$	—	—	0.5		
Output Noise Voltage	V_{NO}	2	$T_a = 25^{\circ}C$, $10Hz \leq f \leq 100kHz$	—	60	—	μV_{rms}	
Ripple Rejection	R.R.	3	$f = 120Hz$, $I_{OUT} = 20mA$	57	64	—	dB	
Short Circuit Current Limit	I_{SC}	1	$T_j = 25^{\circ}C$	—	1.9	—	A	
Average Temperature Coefficient Of Output Voltage	T_{CVO}	1	$I_{OUT} = 5.0mA$	—	1.1	—	$mV/^{\circ}C$	
Dropout Voltage	V_D	1	$T_j = 25^{\circ}C$, $I_{OUT} = 1.0A$	—	2.0	—	V	

TA79010S

ELECTRICAL CHARACTERISTICS

(Unless otherwise specified, $V_{IN} = -16V$, $I_{OUT} = 500mA$, $0^{\circ}C \leq T_j \leq 125^{\circ}C$, $C_{IN} = 1.0\mu F$, $C_{OUT} = 1.0\mu F$)

CHARACTERISTIC	SYMBOL	TEST CIR-CUIT	TEST CONDITION	MIN.	TYP.	MAX.	UNIT	
Output Voltage	V_{OUT}	1	$T_j = 25^{\circ}C$	-10.4	-10	-9.6	V	
Line Regulation	Reg.Line	1	$T_j = 25^{\circ}C$	$-20V \leq V_{IN} \leq -14V$	—	12	90	mV
				$-27V \leq V_{IN} \leq -12.5V$	—	50	180	
Load Regulation	Reg.Load	1	$T_j = 25^{\circ}C$	$5mA \leq I_{OUT} \leq 1.5A$	—	40	180	mV
				$250mA \leq I_{OUT} \leq 750mA$	—	13	90	
Output Voltage	V_{OUT}	1	$T_j = 25^{\circ}C$	-10.5	—	-9.5	V	
Quiescent Current	I_B	1	$T_j = 25^{\circ}C$	—	4.4	8.0	mA	
Quiescent Current Change	Line	1	$-27.5V \leq V_{IN} \leq -14V$	—	—	1.0	mA	
	Load			$5mA \leq I_{OUT} \leq 1.0A$	—	—		0.5
Output Noise Voltage	V_{NO}	2	$T_a = 25^{\circ}C$, $10Hz \leq f \leq 100kHz$	—	65	—	μV_{rms}	
Ripple Rejection	R.R.	3	$f = 120Hz$, $I_{OUT} = 20mA$	57	63	—	dB	
Short Circuit Current Limit	I_{SC}	1	$T_j = 25^{\circ}C$	—	1.9	—	A	
Average Temperature Coefficient Of Output Voltage	T_{CVO}	1	$I_{OUT} = 5.0mA$	—	1.3	—	$mV/^{\circ}C$	
Dropout Voltage	V_D	1	$T_j = 25^{\circ}C$, $I_{OUT} = 1.0A$	—	2.0	—	V	

TA79012S

ELECTRICAL CHARACTERISTICS

(Unless otherwise specified, $V_{IN} = -19V$, $I_{OUT} = 500mA$, $0^{\circ}C \leq T_j \leq 125^{\circ}C$, $C_{IN} = 1.0\mu F$, $C_{OUT} = 1.0\mu F$)

CHARACTERISTIC	SYMBOL	TEST CIR-CUIT	TEST CONDITION	MIN.	TYP.	MAX.	UNIT	
Output Voltage	V_{OUT}	1	$T_j = 25^{\circ}C$	-12.5	-12	-11.5	V	
Line Regulation	Reg.Line	1	$T_j = 25^{\circ}C$	$-22V \leq V_{IN} \leq -16V$	—	13	120	mV
				$-30V \leq V_{IN} \leq -14.5V$	—	55	240	
Load Regulation	Reg.Load	1	$T_j = 25^{\circ}C$	$5mA \leq I_{OUT} \leq 1.5A$	—	46	240	mV
				$250mA \leq I_{OUT} \leq 750mA$	—	17	120	
Output Voltage	V_{OUT}	1	$T_j = 25^{\circ}C$	-12.6	—	-11.4	V	
Quiescent Current	I_B	1	$T_j = 25^{\circ}C$	—	4.4	8.0	mA	
Quiescent Current Change	Line	1	$-30V \leq V_{IN} \leq -14.5V$	—	—	1.0	mA	
	Load			$5mA \leq I_{OUT} \leq 1.0A$	—	—		0.5
Output Noise Voltage	V_{NO}	2	$T_a = 25^{\circ}C$, $10Hz \leq f \leq 100kHz$	—	75	—	μV_{rms}	
Ripple Rejection	R.R.	3	$f = 120Hz$, $I_{OUT} = 20mA$	54	61	—	dB	
Short Circuit Current Limit	I_{SC}	1	$T_j = 25^{\circ}C$	—	1.9	—	A	
Average Temperature Coefficient Of Output Voltage	T_{CVO}	1	$I_{OUT} = 5.0mA$	—	1.6	—	$mV/^{\circ}C$	
Dropout Voltage	V_D	1	$T_j = 25^{\circ}C$, $I_{OUT} = 1.0A$	—	2.0	—	V	

TA79015S

ELECTRICAL CHARACTERISTICS

(Unless otherwise specified, $V_{IN} = -23V$, $I_{OUT} = 500mA$, $0^{\circ}C \leq T_j \leq 125^{\circ}C$, $C_{IN} = 1.0\mu F$, $C_{OUT} = 1.0\mu F$)

CHARACTERISTIC	SYMBOL	TEST CIR-CUIT	TEST CONDITION	MIN.	TYP.	MAX.	UNIT	
Output Voltage	V_{OUT}	1	$T_j = 25^{\circ}C$	-15.6	-15	-14.4	V	
Line Regulation	Reg.Line	1	$T_j = 25^{\circ}C$	$-26V \leq V_{IN} \leq -20V$	—	14	150	mV
				$-30V \leq V_{IN} \leq -17.5V$	—	57	300	
Load Regulation	Reg.Load	1	$T_j = 25^{\circ}C$	$5mA \leq I_{OUT} \leq 1.5A$	—	68	300	mV
				$250mA \leq I_{OUT} \leq 750mA$	—	25	150	
Output Voltage	V_{OUT}	1	$T_j = 25^{\circ}C$	-15.75	—	-14.25	V	
Quiescent Current	I_B	1	$T_j = 25^{\circ}C$	—	4.4	8.0	mA	
Quiescent Current Change	Line	1	$-30V \leq V_{IN} \leq -17.5V$	—	—	1.0	mA	
	Load			$5mA \leq I_{OUT} \leq 1.0A$	—	—		0.5
Output Noise Voltage	V_{NO}	2	$T_a = 25^{\circ}C$, $10Hz \leq f \leq 100kHz$	—	90	—	μV_{rms}	
Ripple Rejection	R.R.	3	$f = 120Hz$, $I_{OUT} = 20mA$	53	60	—	dB	
Short Circuit Current Limit	I_{SC}	1	$T_j = 25^{\circ}C$	—	1.9	—	A	
Average Temperature Coefficient Of Output Voltage	T_{CVO}	1	$I_{OUT} = 5.0mA$	—	2.0	—	$mV/^{\circ}C$	
Dropout Voltage	V_D	1	$T_j = 25^{\circ}C$, $I_{OUT} = 1.0A$	—	2.0	—	V	

TA79018S

ELECTRICAL CHARACTERISTICS

(Unless otherwise specified, $V_{IN} = -27V$, $I_{OUT} = 500mA$, $0^{\circ}C \leq T_j \leq 125^{\circ}C$, $C_{IN} = 1.0\mu F$, $C_{OUT} = 1.0\mu F$)

CHARACTERISTIC	SYMBOL	TEST CIR-CUIT	TEST CONDITION	MIN.	TYP.	MAX.	UNIT	
Output Voltage	V_{OUT}	1	$T_j = 25^{\circ}C$	-18.7	-18	-17.3	V	
Line Regulation	Reg.Line	1	$T_j = 25^{\circ}C$	$-30V \leq V_{IN} \leq -24V$	—	25	180	mV
				$-33V \leq V_{IN} \leq -21V$	—	80	360	
Load Regulation	Reg.Load	1	$T_j = 25^{\circ}C$	$5mA \leq I_{OUT} \leq 1.5A$	—	110	360	mV
				$250mA \leq I_{OUT} \leq 750mA$	—	55	180	
Output Voltage	V_{OUT}	1	$T_j = 25^{\circ}C$	-18.85	—	-17.15	V	
Quiescent Current	I_B	1	$T_j = 25^{\circ}C$	—	4.5	8.0	mA	
Quiescent Current Change	Line	1	$-33V \leq V_{IN} \leq -21V$	—	—	1.0	mA	
	Load			$5mA \leq I_{OUT} \leq 1.0A$	—	—		0.5
Output Noise Voltage	V_{NO}	2	$T_a = 25^{\circ}C$, $10Hz \leq f \leq 100kHz$	—	110	—	μV_{rms}	
Ripple Rejection	R.R.	3	$f = 120Hz$, $I_{OUT} = 20mA$	52	59	—	dB	
Short Circuit Current Limit	I_{SC}	1	$T_j = 25^{\circ}C$	—	1.9	—	A	
Average Temperature Coefficient Of Output Voltage	T_{CVO}	1	$I_{OUT} = 5.0mA$	—	2.5	—	$mV/^{\circ}C$	
Dropout Voltage	V_D	1	$T_j = 25^{\circ}C$, $I_{OUT} = 1.0A$	—	2.0	—	V	

TA79020S

ELECTRICAL CHARACTERISTICS

(Unless otherwise specified, $V_{IN} = -30V$, $I_{OUT} = 500mA$, $0^{\circ}C \leq T_j \leq 125^{\circ}C$, $C_{IN} = 1.0\mu F$, $C_{OUT} = 1.0\mu F$)

CHARACTERISTIC	SYMBOL	TEST CIR-CUIT	TEST CONDITION	MIN.	TYP.	MAX.	UNIT	
Output Voltage	V_{OUT}	1	$T_j = 25^{\circ}C$	-20.8	-20	-19.2	V	
Line Regulation	Reg.Line	1	$T_j = 25^{\circ}C$	$-32V \leq V_{IN} \leq -26V$	—	28	180	mV
				$-35V \leq V_{IN} \leq -24V$	—	104	360	
Load Regulation	Reg.Load	1	$T_j = 25^{\circ}C$	$5mA \leq I_{OUT} \leq 1.5A$	—	130	360	mV
				$250mA \leq I_{OUT} \leq 750mA$	—	70	180	
Output Voltage	V_{OUT}	1	$T_j = 25^{\circ}C$	-21.0	—	-19.0	V	
Quiescent Current	I_B	1	$T_j = 25^{\circ}C$	—	4.6	8.0	mA	
Quiescent Current Change	Line	1	$T_j = 25^{\circ}C$	$-36.5V \leq V_{IN} \leq -25V$	—	—	1.0	mA
	Load			$5mA \leq I_{OUT} \leq 1.0A$	—	—	0.5	
Output Noise Voltage	V_{NO}	2	$T_a = 25^{\circ}C$, $10Hz \leq f \leq 100kHz$	—	140	—	μV_{rms}	
Ripple Rejection	R.R.	3	$f = 120Hz$, $I_{OUT} = 20mA$	50	57	—	dB	
Short Circuit Current Limit	I_{SC}	1	$T_j = 25^{\circ}C$	—	1.9	—	A	
Average Temperature Coefficient Of Output Voltage	T_{CVO}	1	$I_{OUT} = 5.0mA$	—	3.0	—	$mV/^{\circ}C$	
Dropout Voltage	V_D	1	$T_j = 25^{\circ}C$, $I_{OUT} = 1.0A$	—	2.0	—	V	

TA79024S

ELECTRICAL CHARACTERISTICS

(Unless otherwise specified, $V_{IN} = -33V$, $I_{OUT} = 500mA$, $0^{\circ}C \leq T_j \leq 125^{\circ}C$, $C_{IN} = 1.0\mu F$, $C_{OUT} = 1.0\mu F$)

CHARACTERISTIC	SYMBOL	TEST CIR-CUIT	TEST CONDITION	MIN.	TYP.	MAX.	UNIT	
Output Voltage	V_{OUT}	1	$T_j = 25^{\circ}C$	-25.0	-24	-23.0	V	
Line Regulation	Reg.Line	1	$T_j = 25^{\circ}C$	$-36V \leq V_{IN} \leq -30V$	—	31	240	mV
				$-38V \leq V_{IN} \leq -27V$	—	118	480	
Load Regulation	Reg.Load	1	$T_j = 25^{\circ}C$	$5mA \leq I_{OUT} \leq 1.5A$	—	150	480	mV
				$250mA \leq I_{OUT} \leq 750mA$	—	85	240	
Output Voltage	V_{OUT}	1	$T_j = 25^{\circ}C$	-25.2	—	-22.8	V	
Quiescent Current	I_B	1	$T_j = 25^{\circ}C$	—	4.6	8.0	mA	
Quiescent Current Change	Line	1	$-38V \leq V_{IN} \leq -27V$	—	—	1.0	mA	
	Load			$5mA \leq I_{OUT} \leq 1.0A$	—	—		0.5
Output Noise Voltage	V_{NO}	2	$T_a = 25^{\circ}C$, $10Hz \leq f \leq 100kHz$	—	170	—	μV_{rms}	
Ripple Rejection	R.R.	3	$f = 120Hz$, $I_{OUT} = 20mA$	49	56	—	dB	
Short Circuit Current Limit	I_{SC}	1	$T_j = 25^{\circ}C$	—	1.9	—	A	
Average Temperature Coefficient Of Output Voltage	T_{CVO}	1	$I_{OUT} = 5.0mA$	—	3.5	—	$mV/^{\circ}C$	
Dropout Voltage	V_D	1	$T_j = 25^{\circ}C$, $I_{OUT} = 1.0A$	—	2.0	—	V	

TEST CIRCUIT

1. V_{OUT} , Reg.line, Reg.load, I_B , ΔI_B , V_D , T_{CVO}

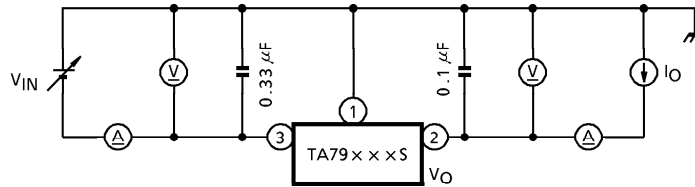

2. V_{NO}

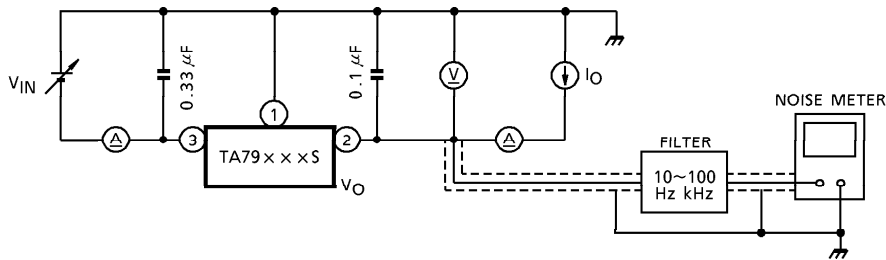

3. R.R.

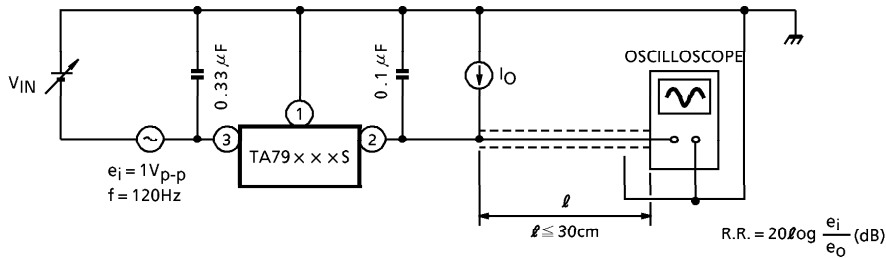

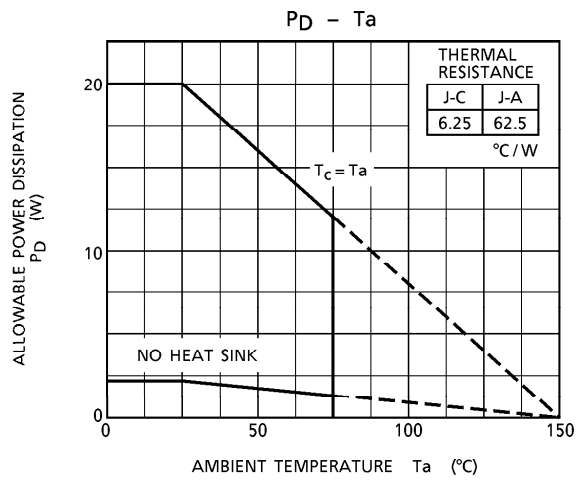
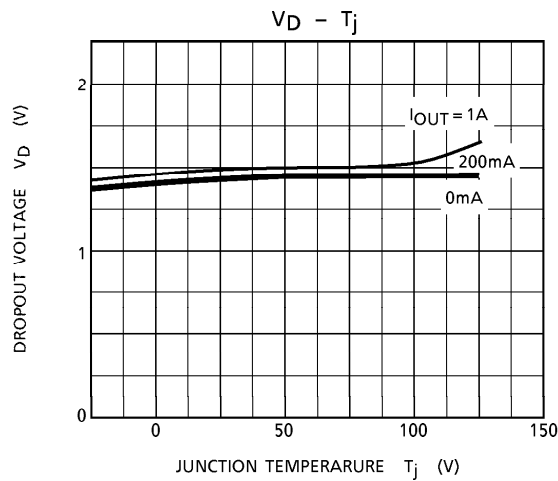
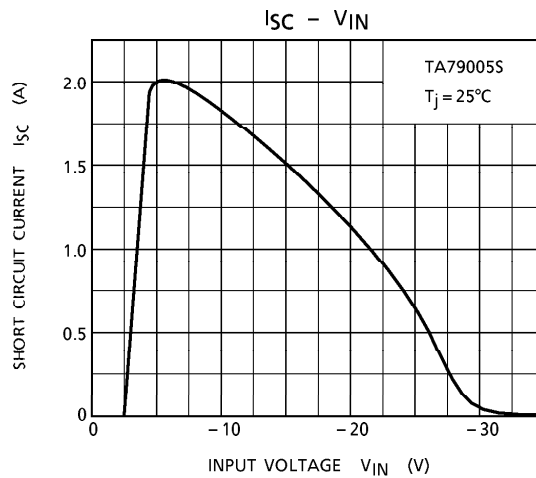
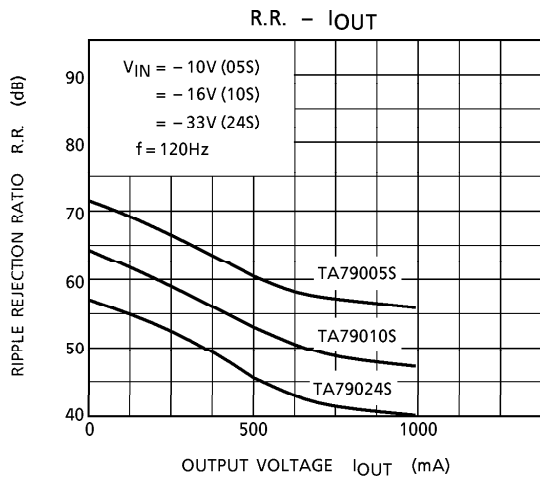
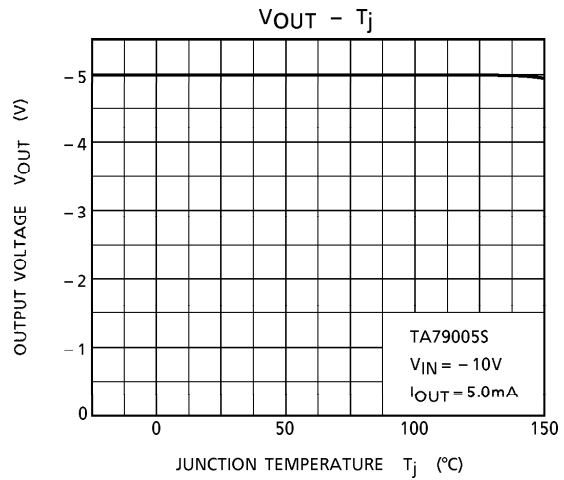
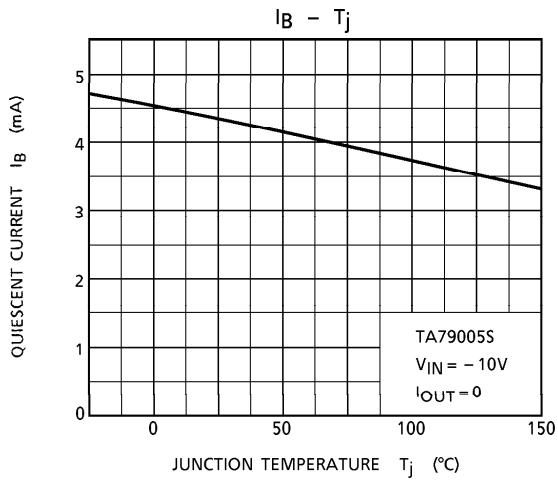

OUTLINE DRAWING
HSIP3-P-2.54A

Unit : mm

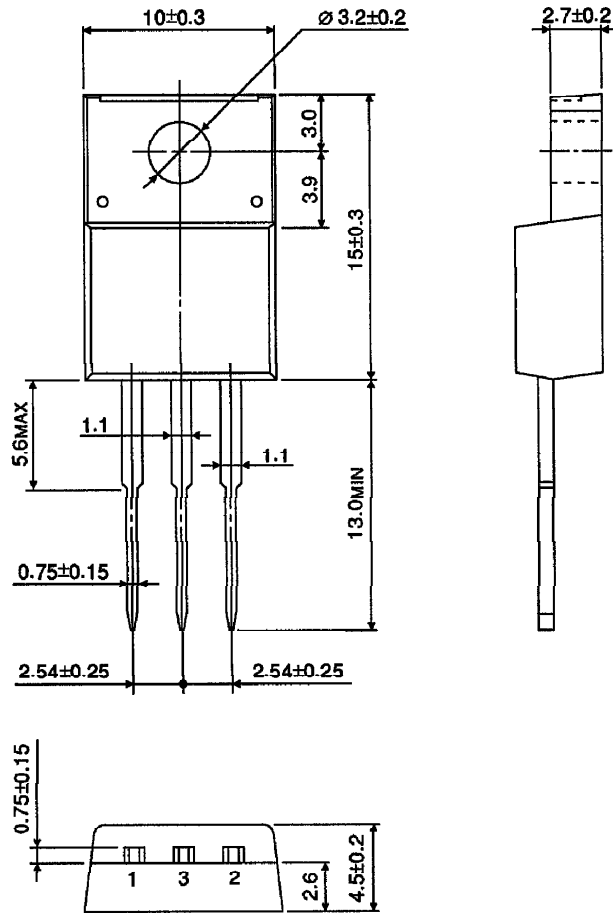

Weight : 1.7g (Typ.)