

Silicon NPN Power Transistors

2SD5071

DESCRIPTION

- With TO-3PML package
- High speed
- High breakdown voltage
- Built-in damper diode

APPLICATIONS

- Color TV horizontal output application

PINNING

PIN	DESCRIPTION
1	Base
2	Collector
3	Emitter

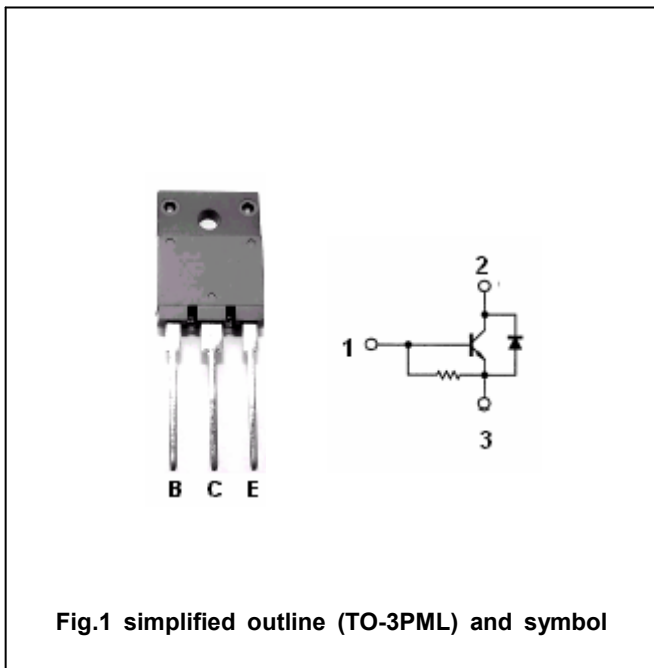

Fig.1 simplified outline (TO-3PML) and symbol

Absolute maximum ratings(Ta=25°C)

SYMBOL	PARAMETER	CONDITIONS	VALUE	UNIT
V _{CBO}	Collector-base voltage	Open emitter	1500	V
V _{CEO}	Collector-emitter voltage	Open base	800	V
V _{EBO}	Emitter-base voltage	Open collector	6	V
I _C	Collector current		3.5	A
I _{CM}	Collector current-peak		10	A
P _C	Collector power dissipation	T _C =25°C	50	W
T _j	Junction temperature		150	°C
T _{stg}	Storage temperature		-55~150	°C

Silicon NPN Power Transistors

2SD5071

CHARACTERISTICS

T_j=25 °C unless otherwise specified

SYMBOL	PARAMETER	CONDITIONS	MIN	TYP.	MAX	UNIT
V _{CEsat}	Collector-emitter saturation voltage	I _C =2.5 A; I _B =0.8A			8.0	V
V _{BEsat}	Base-emitter saturation voltage	I _C =2.5 A; I _B =0.8A			1.5	V
I _{CBO}	Collector cut-off current	V _{CB} =800V; I _E =0			10	μA
I _{EBO}	Emitter cut-off current	V _{EB} =4V; I _C =0	40		200	mA
h _{FE}	DC current gain	I _C =0.5A ; V _{CE} =5V	8			
f _T	Transition frequency	I _C =0.5A ; V _{CE} =10V		3		MHz
V _F	Diode forward voltage	I _F =3.5A			2.0	V
t _f	Fall time	I _C =3A; R _L =66.7Ω; V _{CC} =200V I _{B1} =0.8A; I _{B2} =-1.6A			0.4	μs

Silicon NPN Power Transistors

2SD5071

PACKAGE OUTLINE

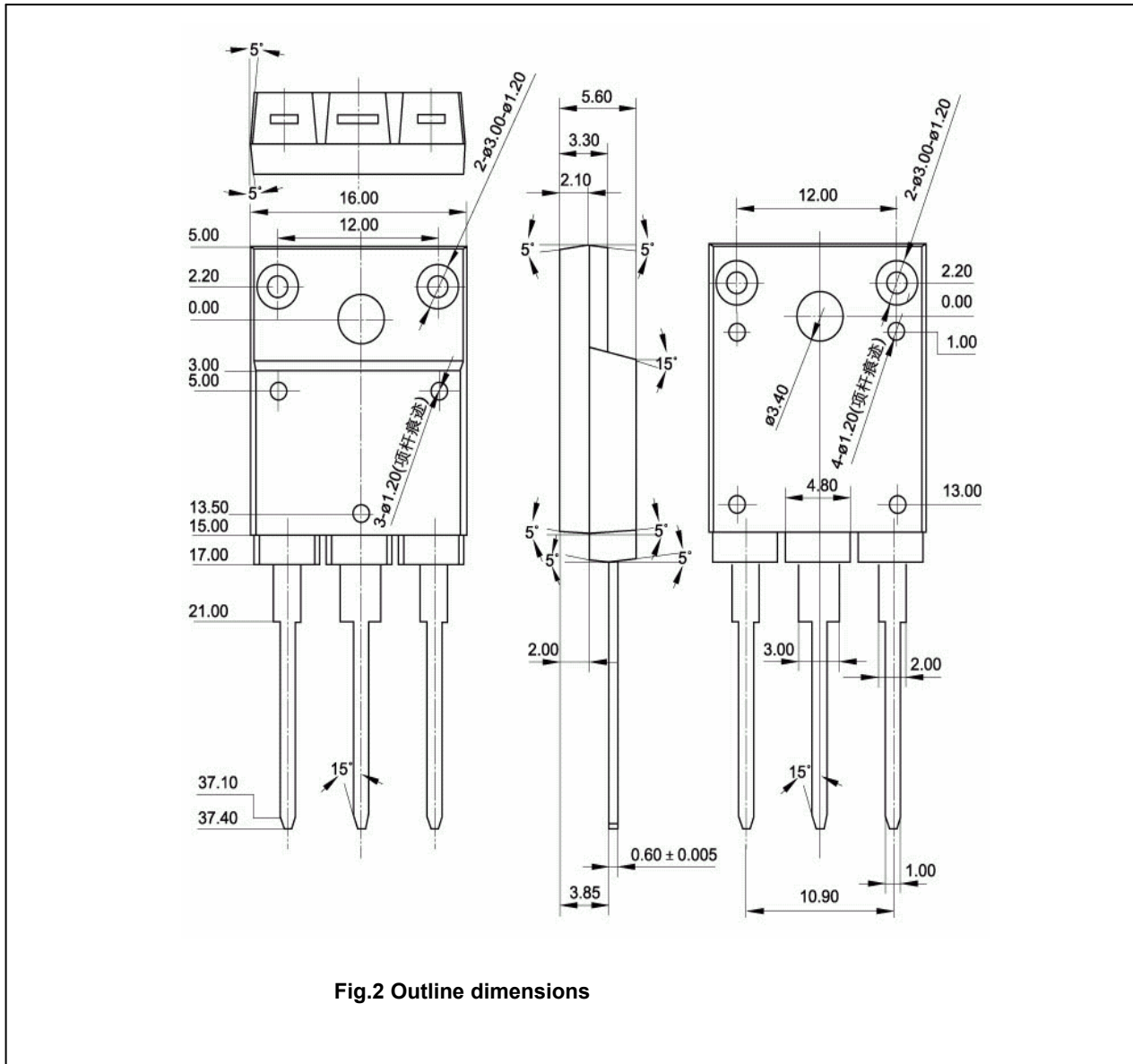

Fig.2 Outline dimensions