

Silicon NPN Power Transistors

2SD1763

DESCRIPTION

- With TO-220Fa package
- High breakdown voltage V_{CEO}
- Complement to type 2SB1186
- High transition frequency

APPLICATIONS

- For low frequency power amplifier applications

PINNING

PIN	DESCRIPTION
1	Base
2	Collector
3	Emitter

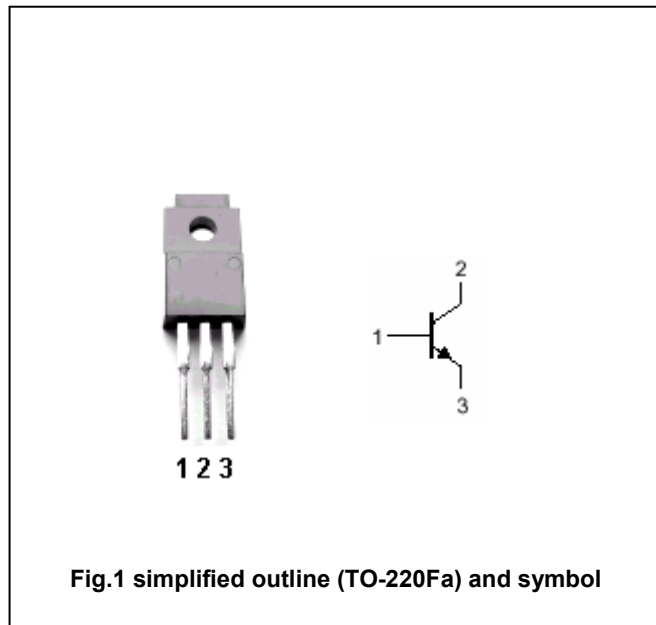
Absolute maximum ratings($T_a=25^\circ\text{C}$)

SYMBOL	PARAMETER	CONDITIONS	VALUE	UNIT
V_{CBO}	Collector-base voltage	Open emitter	120	V
V_{CEO}	Collector-emitter voltage	Open base	120	V
V_{EBO}	Emitter-base voltage	Open collector	5	V
I_C	Collector current (DC)		2	A
I_{CM}	Collector current-Peak		3	A
P_C	Collector power dissipation	$T_C=25^\circ\text{C}$	20	W
T_j	Junction temperature		150	$^\circ\text{C}$
T_{stg}	Storage temperature		-55~150	$^\circ\text{C}$

Silicon NPN Power Transistors

2SD1763

CHARACTERISTICS

T_j=25°C unless otherwise specified

SYMBOL	PARAMETER	CONDITIONS	MIN	TYP.	MAX	UNIT
V _{(BR)CEO}	Collector-emitter breakdown voltage	I _C =1mA, I _B =0	120			V
V _{(BR)CBO}	Collector-base breakdown voltage	I _C =50μA, I _E =0	120			V
V _{(BR)EBO}	Emitter-base breakdown voltage	I _E =50μA, I _C =0	5			V
V _{CEsat}	Collector-emitter saturation voltage	I _C =1A; I _B =0.1A			0.4	V
V _{BEsat}	Base-emitter saturation voltage	I _C =1A; I _B =0.1A			1.5	V
I _{CBO}	Collector cut-off current	V _{CB} =100V, I _E =0			1	μA
I _{EBO}	Emitter cut-off current	V _{EB} =4V; I _C =0			1	μA
h _{FE}	DC current gain	I _C =0.1A; V _{CE} =5V	100		320	
f _T	Transition frequency	I _E =-0.1A; V _{CE} =5V		80		MHz
C _{ob}	Output capacitance	I _E =0; V _{CB} =10V, f=1MHz		20		pF

◆ h_{FE} Classifications

E	F
100-200	160-320

Silicon NPN Power Transistors

2SD1763

PACKAGE OUTLINE

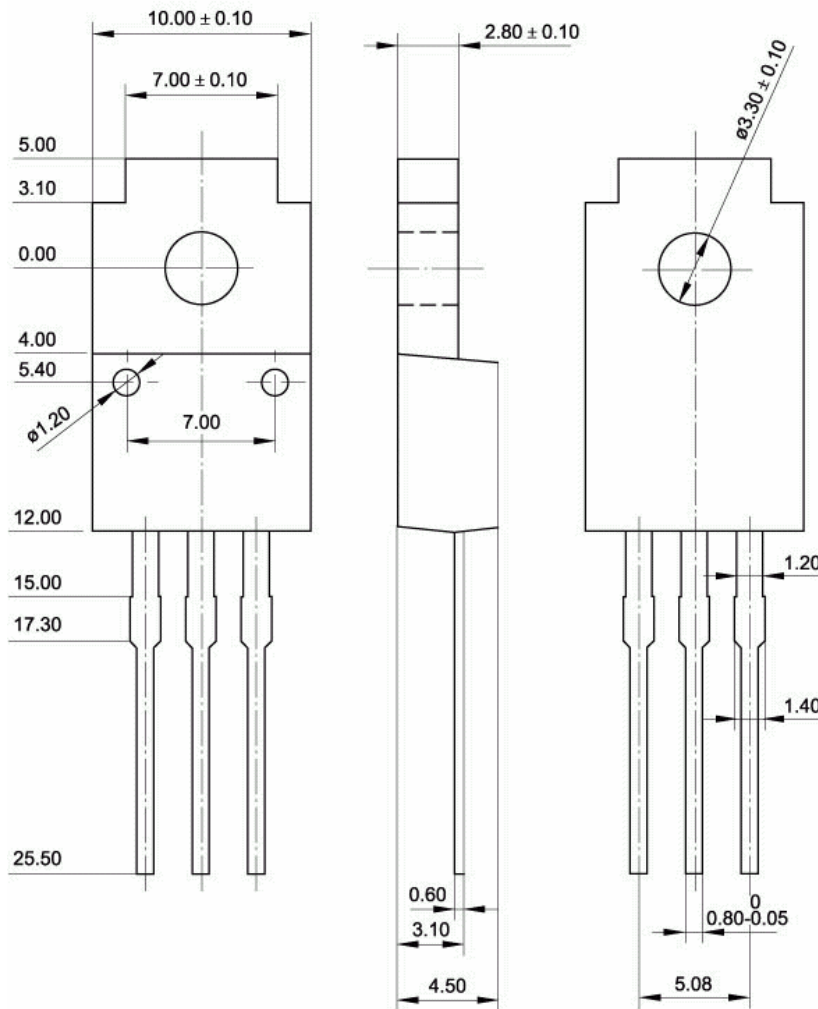

Fig.2 Outline dimensions (unindicated tolerance: ± 0.15 mm)