

Silicon NPN Power Transistors

2SC2344

DESCRIPTION

- With TO-220 package
- Complement to type 2SA1011

APPLICATIONS

- High voltage switching
- Audio frequency power amplifier;
- 100W output predriver applications

PINNING

PIN	DESCRIPTION
1	Base
2	Collector;connected to mounting base
3	Emitter

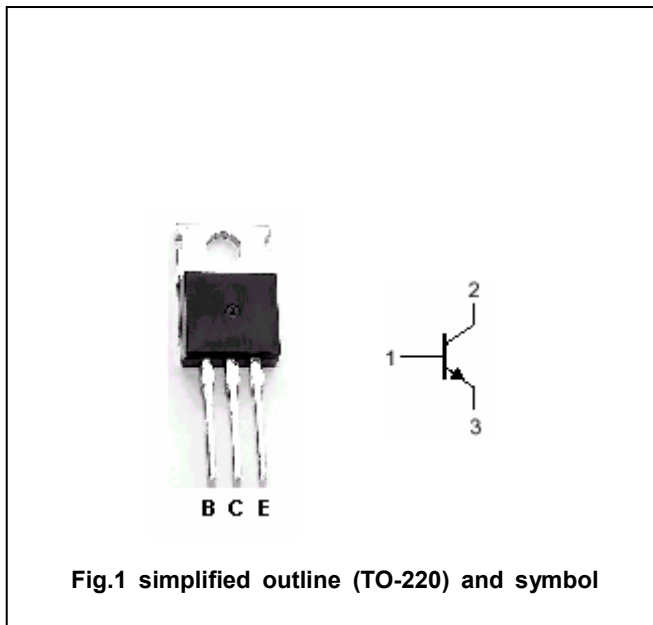

Absolute maximum ratings(Ta=25°C)

SYMBOL	PARAMETER	CONDITIONS	VALUE	UNIT
V _{CBO}	Collector-base voltage	Open emitter	180	V
V _{CEO}	Collector-emitter voltage	Open base	160	V
V _{EBO}	Emitter-base voltage	Open collector	6	V
I _C	Collector current		1.5	A
I _{CM}	Collector current-Peak		3.0	A
P _T	Total power dissipation	T _C =25°C	25	W
T _j	Junction temperature		150	°C
T _{stg}	Storage temperature		-55~150	°C

Silicon NPN Power Transistors

2SC2344

CHARACTERISTICS

T_j=25°C unless otherwise specified

SYMBOL	PARAMETER	CONDITIONS	MIN	TYP.	MAX	UNIT
V _{(BR)CEO}	Base-emitter breakdown voltage	I _C =10mA, R _{BE} =∞	160			V
V _{(BR)CBO}	Collector-base breakdown voltage	I _C =1mA; I _E =0	180			V
V _{(BR)EBO}	Emitter-base breakdown voltage	I _E =1mA; I _C =0	6			V
V _{CEsat}	Collector-emitter saturation voltage	I _C =0.5A; I _B =50mA		0.3		V
V _{BE}	Base-emitter voltage	I _C =10mA; V _{CE} =5V		1.5		V
I _{CBO}	Collector cut-off current	V _{CB} =120V; I _E =0			10	μA
I _{EBO}	Emitter cut-off current	V _{EB} =4V; I _C =0			10	μA
h _{FE}	DC current gain	I _C =0.3A; V _{CE} =5V	60		200	
f _T	Transition frequency	I _C =50mA; V _{CE} =10V		100		MHz
C _{ob}	Output capacitance	f=1MHz; V _{CB} =10V		23		pF

Switching times resistive load

t _{on}	Turn-on time	I _C =0.5A I _{B1} =- I _{B2} =50mA		0.15		μs
t _s	Storage time			0.81		μs
t _f	Fall time			0.48		μs

◆ h_{FE} Classifications

D	E
60-120	100-200

Silicon NPN Power Transistors

2SC2344

PACKAGE OUTLINE

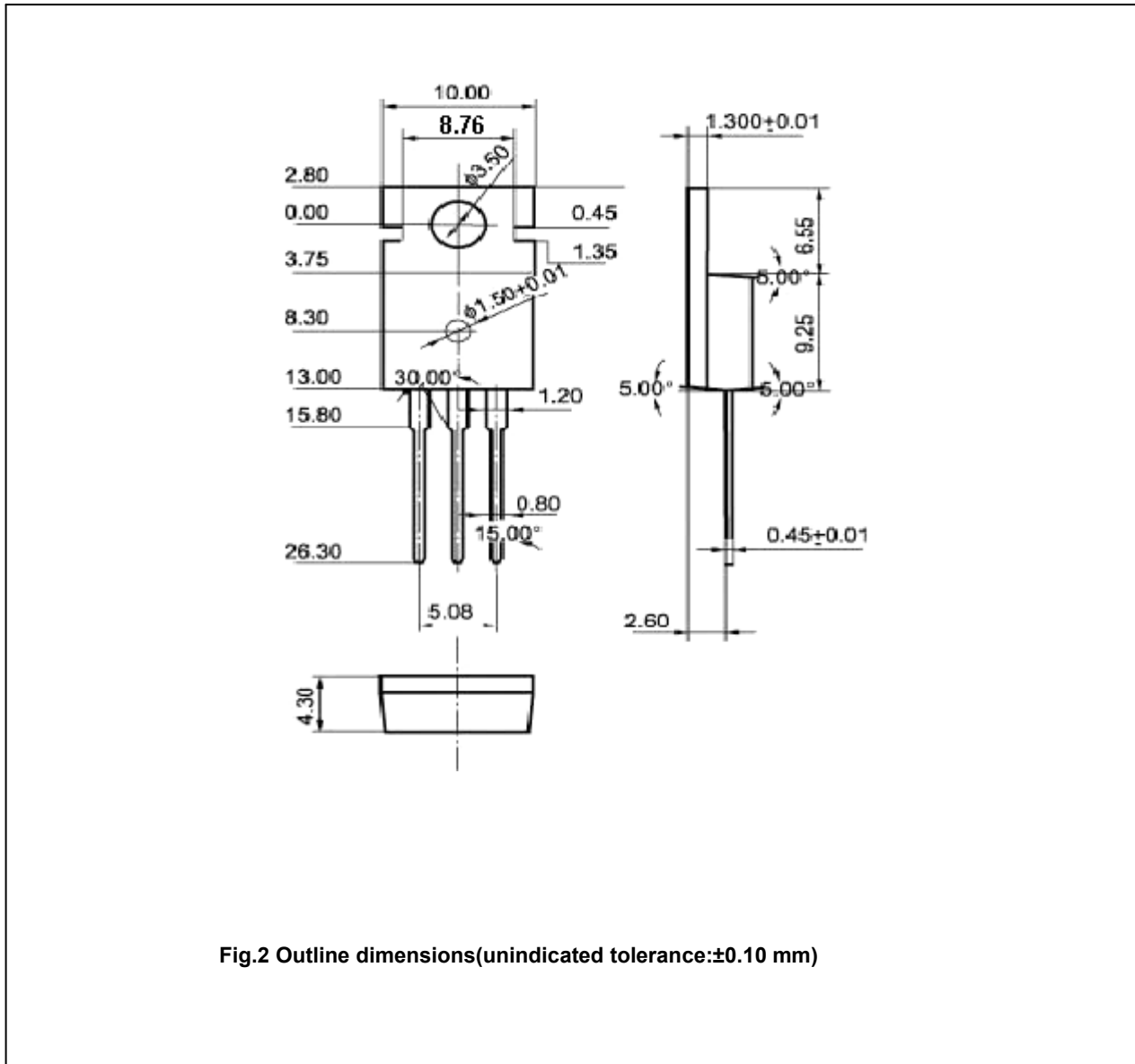

Fig.2 Outline dimensions(unindicated tolerance:±0.10 mm)

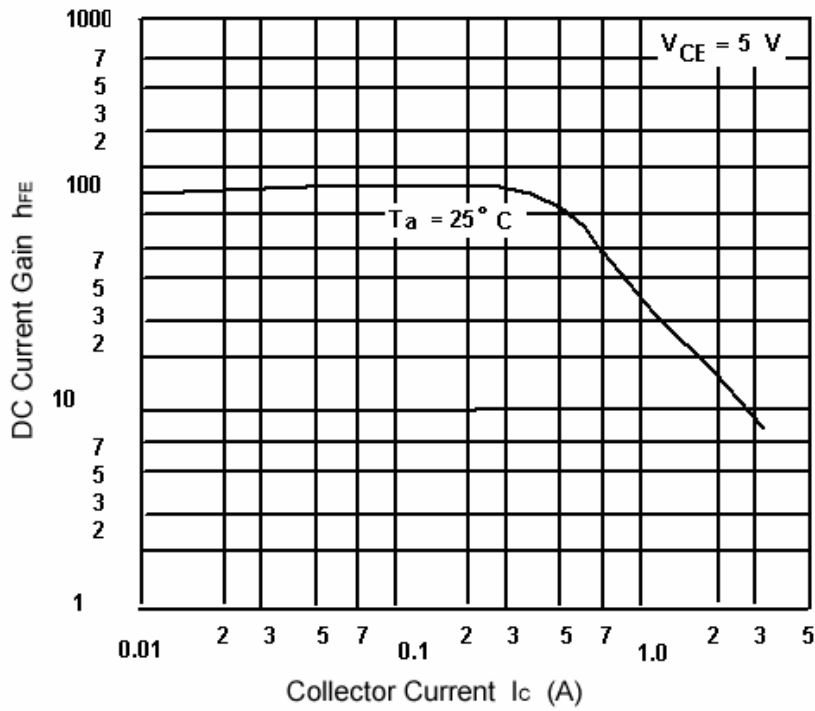

Fig.3 DC current Gain

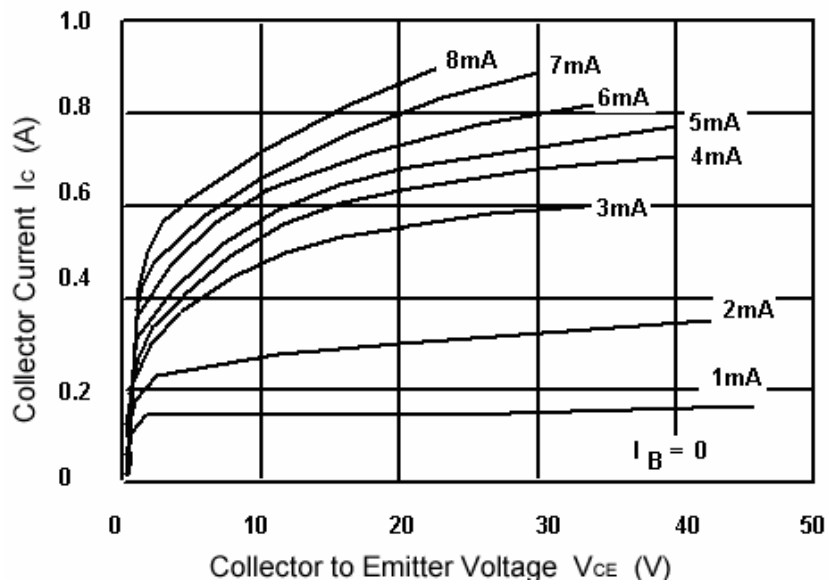

Fig.4 Static Characteristic

Silicon NPN Power Transistors

2SC2344

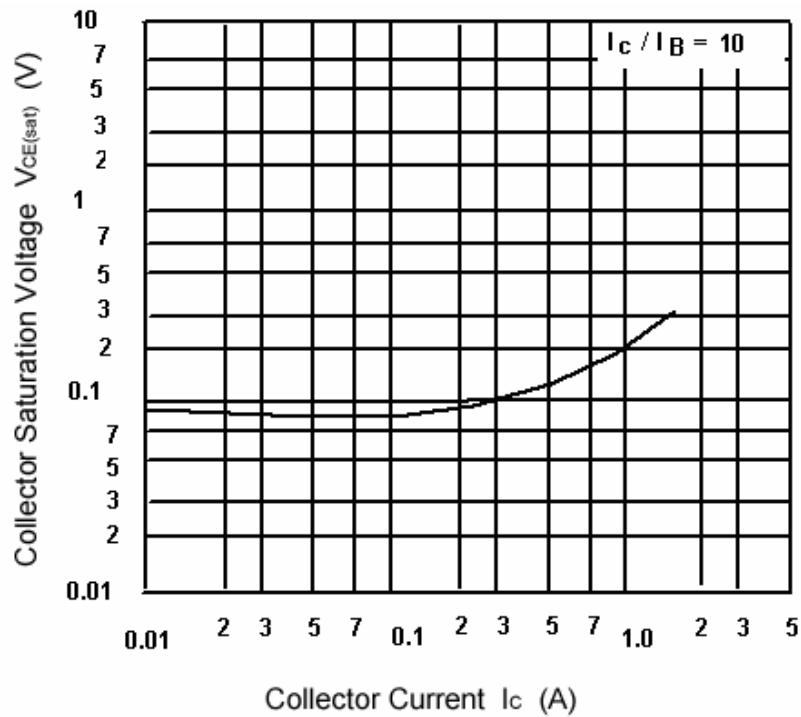

Fig.5 Collector-Emitter Saturation Voltage

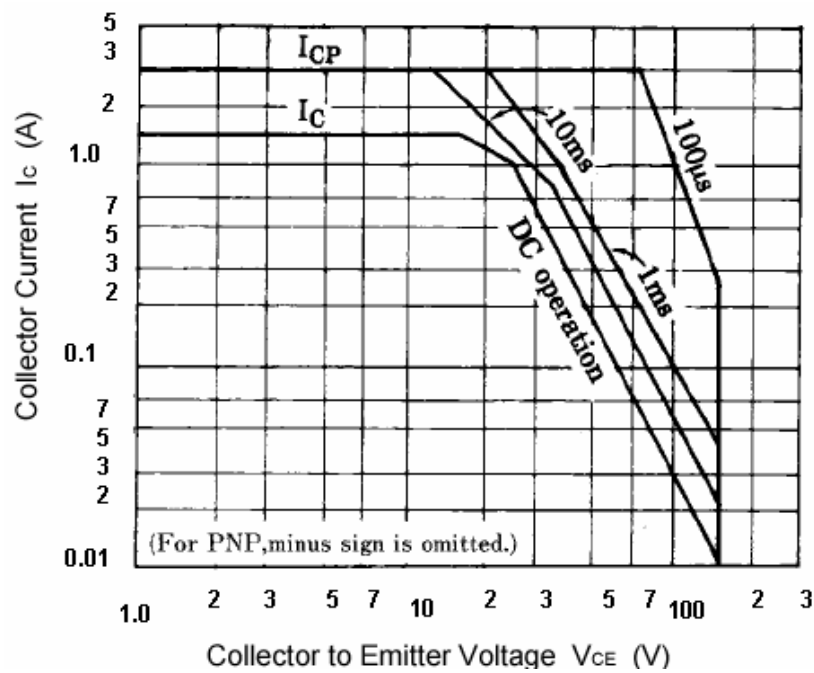

Fig.6 Safe Operating Area