

## Silicon NPN Power Transistors

2SC1108

**DESCRIPTION**

- With TO-220C package
- High breakdown voltage : $V_{CE0}=100V$
- High current :4A

**APPLICATIONS**

- For power amplifier applications

**PINNING**

PIN	DESCRIPTION
1	Base
2	Collector;connected to mounting base
3	Emitter

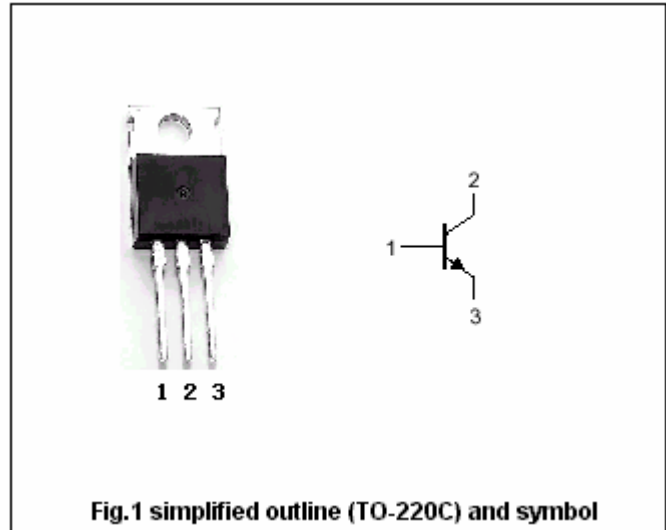
**Absolute maximum ratings( $T_c=25^\circ$ )**

SYMBOL	PARAMETER	CONDITIONS	VALUE	UNIT
$V_{CBO}$	Collector-base voltage	Open emitter	100	V
$V_{CEO}$	Collector-emitter voltage	Open base	100	V
$V_{EBO}$	Emitter-base voltage	Open collector	5	V
$I_C$	Collector current		4	A
$P_C$	Collector power dissipation	$T_C=25^\circ$	40	W
$T_j$	Junction temperature		150	?
$T_{stg}$	Storage temperature		-55~150	?

## Silicon NPN Power Transistors

## 2SC1108

## CHARACTERISTICS

T<sub>j</sub>=25° unless otherwise specified

SYMBOL	PARAMETER	CONDITIONS	MIN	TYP.	MAX	UNIT
V <sub>(BR)CEO</sub>	Collector-emitter breakdown voltage	I <sub>C</sub> =25mA; I <sub>B</sub> =0	100			V
V <sub>(BR)EBO</sub>	Emitter-base breakdown voltage	I <sub>E</sub> =1mA; I <sub>C</sub> =0	5			V
V <sub>CEsat</sub>	Collector-emitter saturation voltage	I <sub>C</sub> =3A; I <sub>B</sub> =0.3 A			1.5	V
V <sub>BEsat</sub>	Base-emitter saturation voltage	I <sub>C</sub> =3A; I <sub>B</sub> =0.3 A			2.0	V
I <sub>CBO</sub>	Collector cut-off current	V <sub>CB</sub> =100V; I <sub>E</sub> =0			0.1	mA
I <sub>EBO</sub>	Emitter cut-off current	V <sub>EB</sub> =5V; I <sub>C</sub> =0			0.1	mA
h <sub>FE</sub>	DC current gain	I <sub>C</sub> =1A ; V <sub>CE</sub> =4V	100		320	
f <sub>T</sub>	Transition frequency	I <sub>C</sub> =0.5A ; V <sub>CE</sub> =12V		10		MHz
C <sub>OB</sub>	Output capacitance	I <sub>E</sub> =0; V <sub>CB</sub> =10V; f=1MHz	25			pF

Silicon NPN Power Transistors

2SC1108

PACKAGE OUTLINE

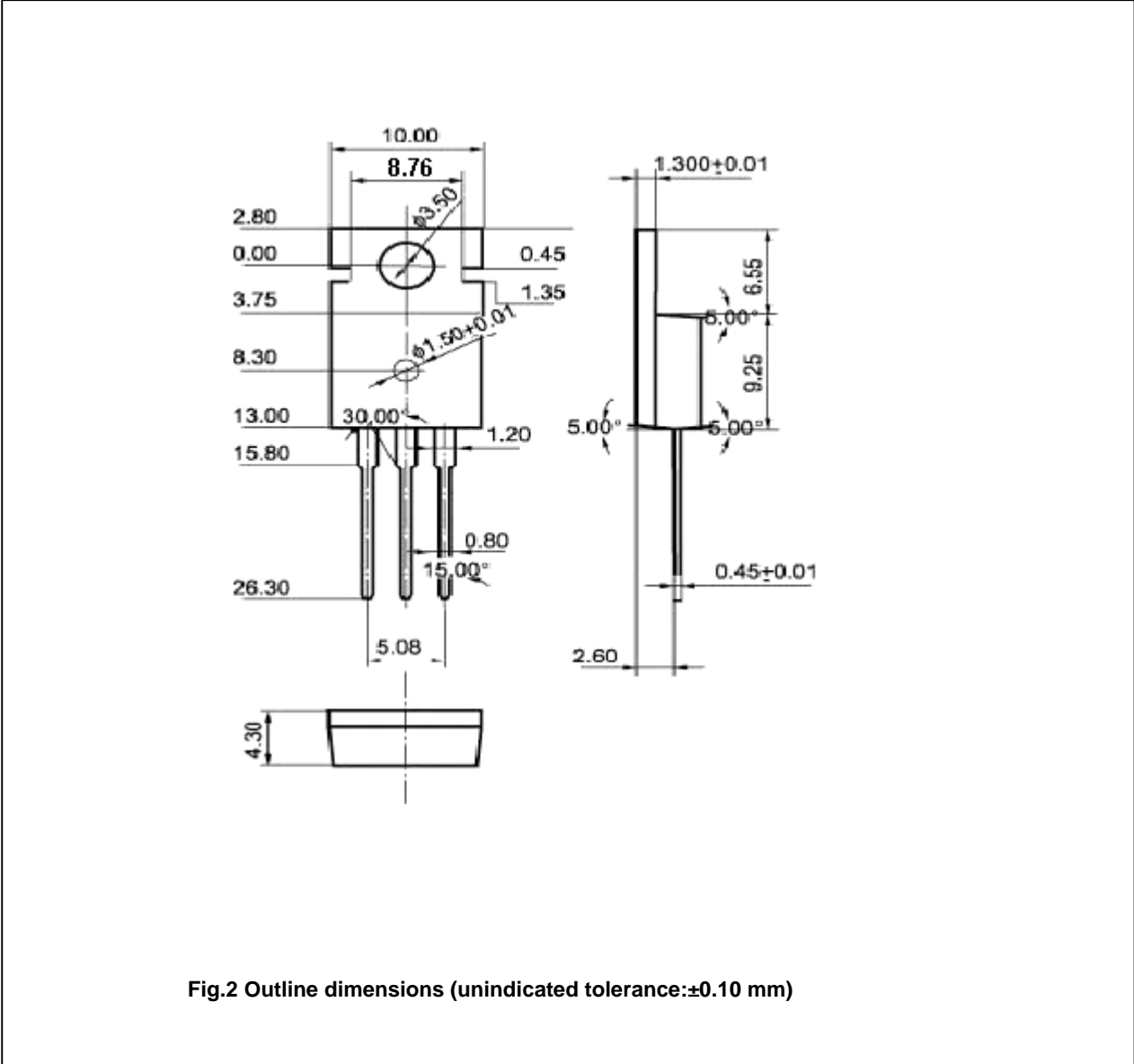

Fig.2 Outline dimensions (unindicated tolerance:±0.10 mm)