

## SAB 8286A/SAB 8287A Octal Bus Transceiver

- Fully compatible with SAB 8286/SAB 8287
- 40% Less Power Supply Current than Standard SAB 8286/SAB 8287
- Data Bus Buffer Driver for SAB 80286, SAB 80186, SAB 8086, SAB 8085, SAB 8048 and SAB 8051 Families
- High Output Drive Capability for Driving System Data Bus
- Fully Parallel 8-Bit Transceivers
- 3-State Outputs
- 20-Pin Package
- No Output Low Noise when Entering or Leaving High Impedance State

### Functional Description

The SAB 8286A and SAB 8287A transceivers are 8-bit transceivers with high impedance outputs. With T active HIGH and OE active LOW, data at the A<sub>0</sub>-A<sub>7</sub> pins is driven onto the B<sub>0</sub>-B<sub>7</sub> pins.

With T inactive LOW and OE active LOW, data at the B<sub>0</sub>-B<sub>7</sub> pins is driven onto the A<sub>0</sub>-A<sub>7</sub> pins. No output low glitching will occur whenever the transceivers are entering or leaving the high impedance state.

### Absolute Maximum Ratings<sup>1)</sup>

Temperature Under Bias	0 to +70°C
Storage Temperature	-65 to +150°C
All Output and Supply Voltages	-0.5 to +7 V
All Input Voltages	-1.0 to +5.5V
Power Dissipation	1W

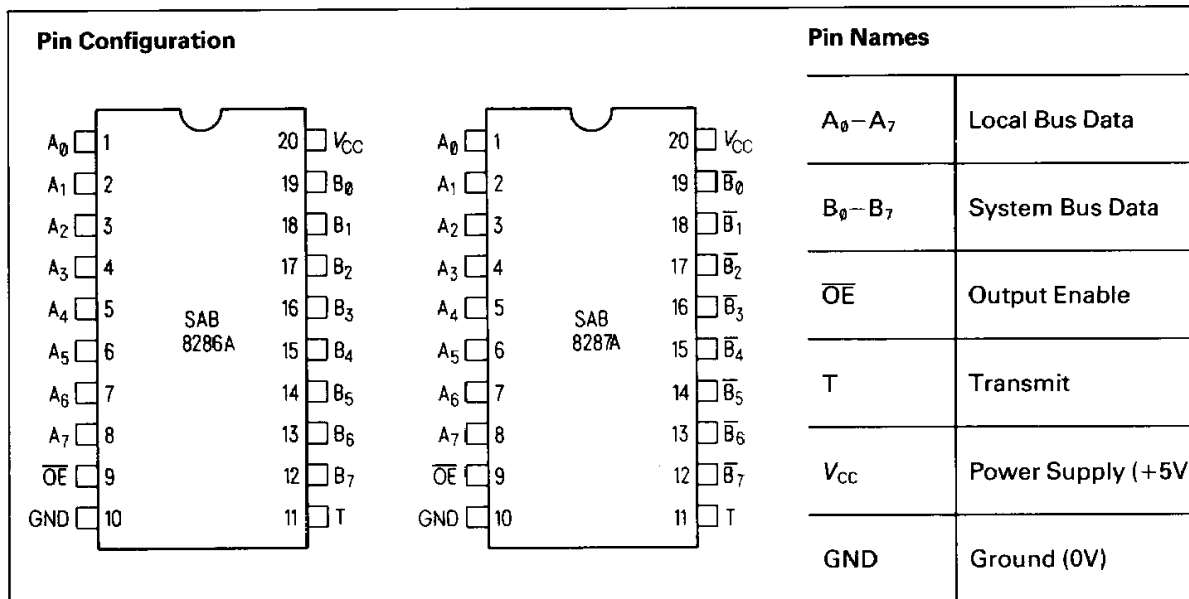

The SAB 8286A and SAB 8287A are 8-bit bipolar transceivers with 3-state outputs. The SAB 8287A inverts the input data at its outputs while the SAB 8286A does not. Thus, a wide variety of applications for

buffering in microcomputer systems can be met. This device is fabricated in a fast bipolar ASBC (Advanced Standard Buried Collector) process of Siemens.

# SAB 8286A / SAB 8287A

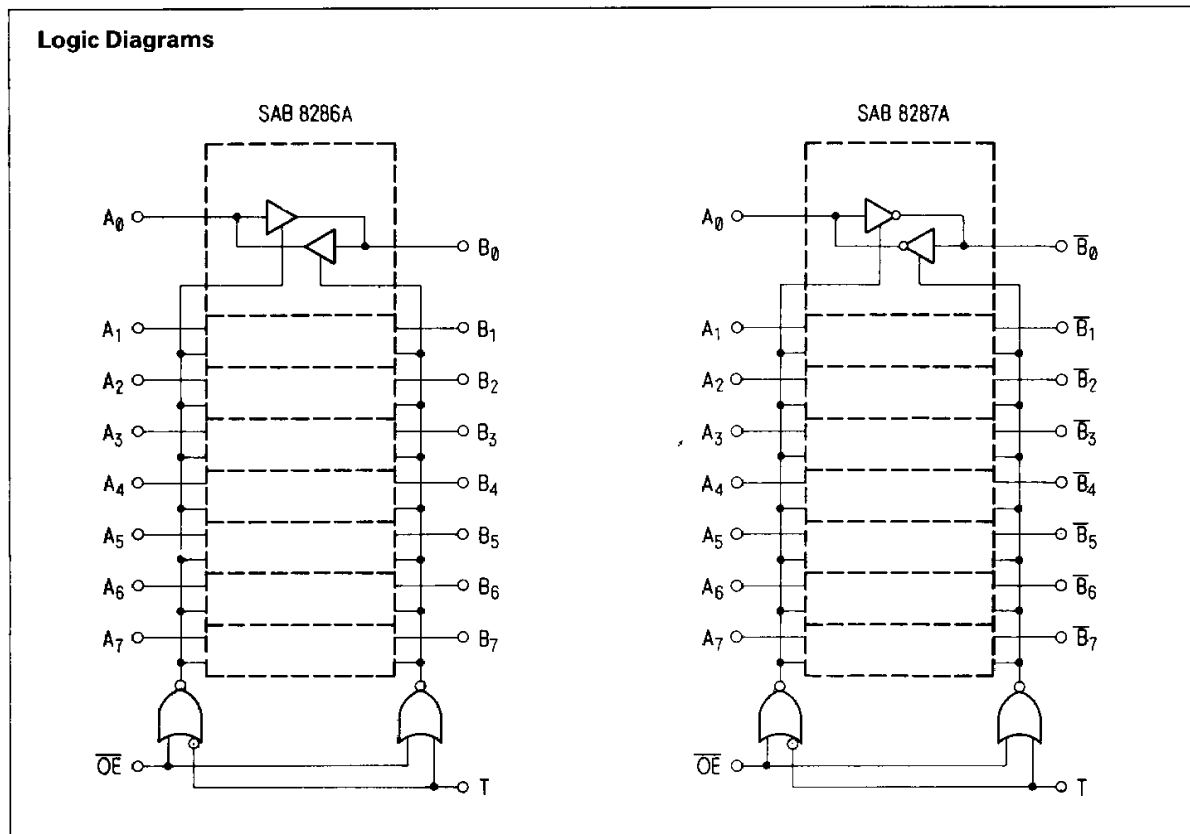

## Pin Definitions and Functions

Symbol	Number	Input (I) Output (O)	Function
T	11	I.	TRANSMIT – T is an input control signal used to control the direction of the transceivers. When HIGH, it configures the transceiver's B <sub>0</sub> –B <sub>7</sub> as outputs with A <sub>0</sub> –A <sub>7</sub> as inputs. T LOW configures A <sub>0</sub> –A <sub>7</sub> as the outputs with B <sub>0</sub> –B <sub>7</sub> serving as the inputs.
OE	9	I	OUTPUT ENABLE – OE is an input control signal used to enable the appropriate output driver (as selected by T) onto its respective bus. This signal is active LOW.
A <sub>0</sub> –A <sub>7</sub>	1–8	I/O	LOCAL BUS DATA PINS – These pins serve to either present data to or accept data from the processor's local bus depending upon the state of the T pin.
B <sub>0</sub> –B <sub>7</sub> (SAB 8286A) B <sub>0</sub> –B <sub>7</sub> (SAB 8287A)	12–19	I/O	SYSTEM BUS DATA PINS – These pins serve to either present data to or accept data from the system bus depending upon the state of the T pin.
V <sub>CC</sub>	20	–	Power Supply (+5V)
GND	10	–	Ground (0V)

## Functional Description

The SAB 8286A and SAB 8287A transceivers are 8-bit transceivers with high impedance outputs. With T active HIGH and  $\overline{OE}$  active LOW, data at the  $A_0$ – $A_7$  pins is driven onto the  $B_0$ – $B_7$  pins.

With T inactive LOW and  $\overline{OE}$  active LOW, data at the  $B_0$ – $B_7$  pins is driven onto the  $A_0$ – $A_7$  pins. No output low glitching will occur whenever the transceivers are entering or leaving the high impedance state.

## Absolute Maximum Ratings<sup>1)</sup>

Temperature Under Bias	0 to +70°C
Storage Temperature	–65 to +150°C
All Output and Supply Voltages	–0.5 to +7V
All Input Voltages	–1.0 to +5.5V
Power Dissipation	1W

## D. C. Characteristics

$T_A = 0$  to  $70^\circ\text{C}$ ;  $V_{CC} = +5\text{V} \pm 10\%$

Symbol	Parameter	Limit Values		Unit	Test Condition
		Min.	Max.		
$V_C$	Input Clamp Voltage	–	–1	V	$I_C = -5\text{ mA}$
$I_{CC}$	Power Supply Current	–	90	mA	All outputs open
$I_F$	Forward Input Current	–	–0.2		$V_F = 0.45\text{V}$
$I_R$	Reverse Input Current	–	50	$\mu\text{A}$	$V_R = 5.25\text{V}$
$V_{OL}$	Output LOW Voltage – B Outputs – A Outputs	–	0.45 0.45	V	$I_{OL} = 32\text{ mA}$ $I_{OL} = 16\text{ mA}$
$V_{OH}$	Output HIGH Voltage – B Outputs – A Outputs	2.4 2.4	–		$I_{OH} = -5\text{ mA}$ $I_{OH} = -1\text{ mA}$
$I_{OFF}$ $I_{OFF}$	Output Off Current Output Off Current	–	$I_F$ $I_R$	–	$V_{OFF} = 0.45\text{V}$ $V_{OFF} = 5.25\text{V}$
$V_{IL}$	Input LOW Voltage – A Side – B Side	–	0.8 0.9	V	$V_{CC} = 5.0\text{V}$ , See Note 2 $V_{CC} = 5.0\text{V}$ , See Note 2
$V_{IH}$	Input HIGH Voltage	2.0	–		$V_{CC} = 5.0\text{V}$ , See Note 2
$C_{IN}$	Input Capacitance	–	12	pF	$F = 1\text{ MHz}$ $V_{BIAS} = 2.5\text{V}$ , $V_{CC} = 5\text{V}$ $T_A = 25^\circ\text{C}$

1) Stresses above those listed under "Absolute Maximum Ratings" may cause permanent damage to the device. Exposure to absolute maximum rating conditions for extended periods may affect device reliability.

2) B Outputs:  $I_{OL} = 32\text{ mA}$ ;  $I_{OH} = -5\text{ mA}$ ;  $C_L = 300\text{ pF}$   
A Outputs:  $I_{OL} = 16\text{ mA}$ ;  $I_{OH} = -1\text{ mA}$ ;  $C_L = 100\text{ pF}$

# SAB 8286A / SAB 8287A

## A.C. Characteristics

$T_A = 0$  to  $+70^\circ\text{C}$ ;  $V_{CC} = +5\text{ V} \pm 10\%$

### Loading

B Outputs:  $I_{OL} = 32\text{ mA}$ ;  $I_{OH} = -5\text{ mA}$ ;  $C_L = 300\text{ pF}$     A Outputs:  $I_{OL} = 16\text{ mA}$ ;  $I_{OH} = -1\text{ mA}$ ;  $C_L = 100\text{ pF}$

Symbol	Parameter	Limit Values		Unit	Test Condition
		Min.	Max.		
$t_{IVOV}$	Input to Output Delay Inverting Non-Inverting	5 5	22 30	ns	1)
$t_{EHTV}$	Transmit/Receive Hold Time	5	-		
$t_{TVEL}$	Transmit/Receive Setup	10	-		
$t_{EHOZ}$	Output Disable Time	5	18		
$t_{ELOV}$	Output Enable Time	10	30		
$t_{LIH}, t_{LOH}$	Input, Output Rise Time	-	20		From 0.8 to 2.0 V
$t_{HIL}, t_{HOL}$	Input, Output Fall Time	-	12	From 2.0 to 0.8 V	

1) See waveforms and test load circuit.

## Waveforms

All timing measurements are made at 1.5 V unless otherwise noted.

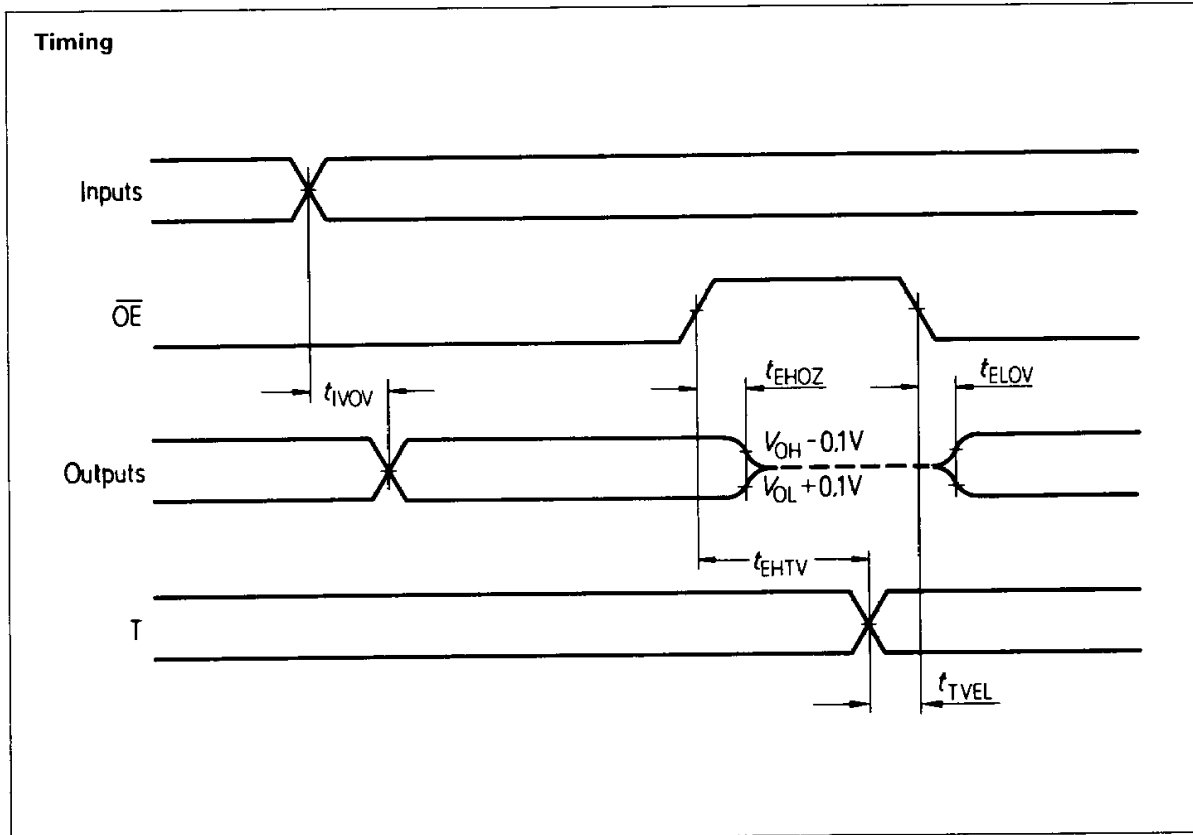

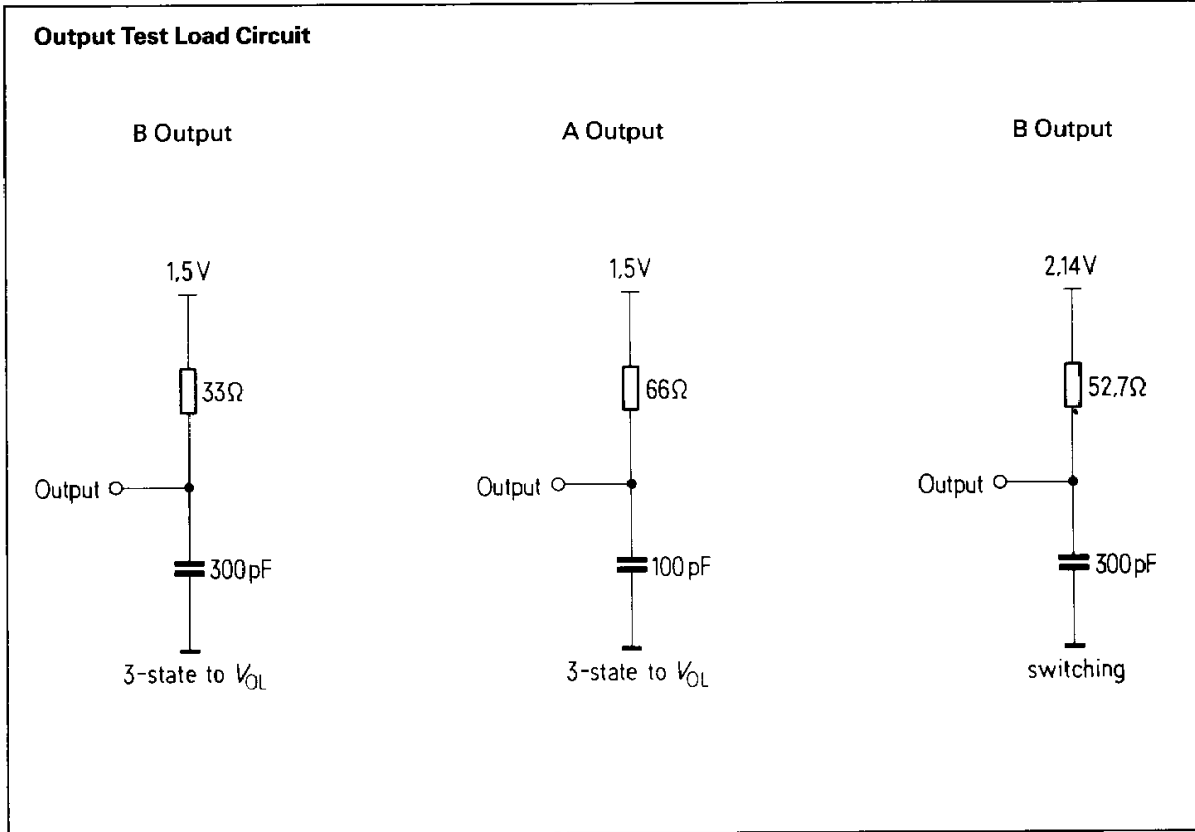
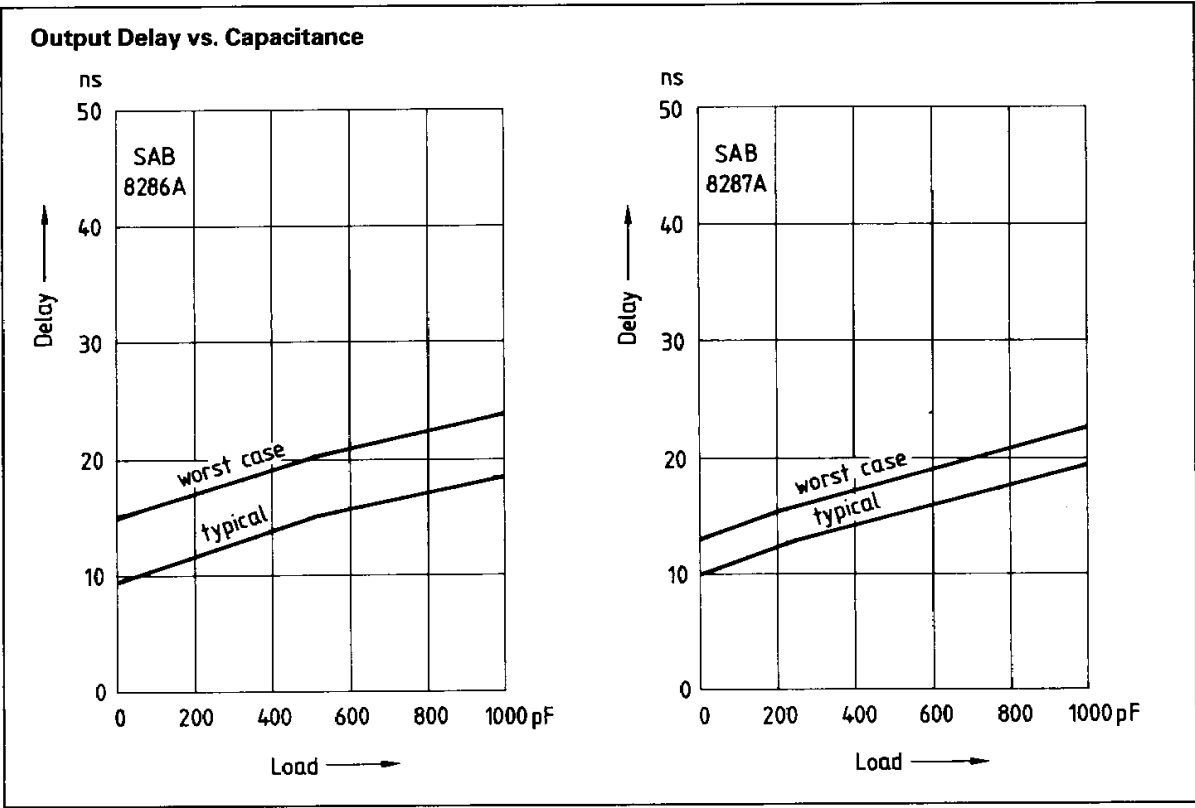

## SAB 8286A / SAB 8287A

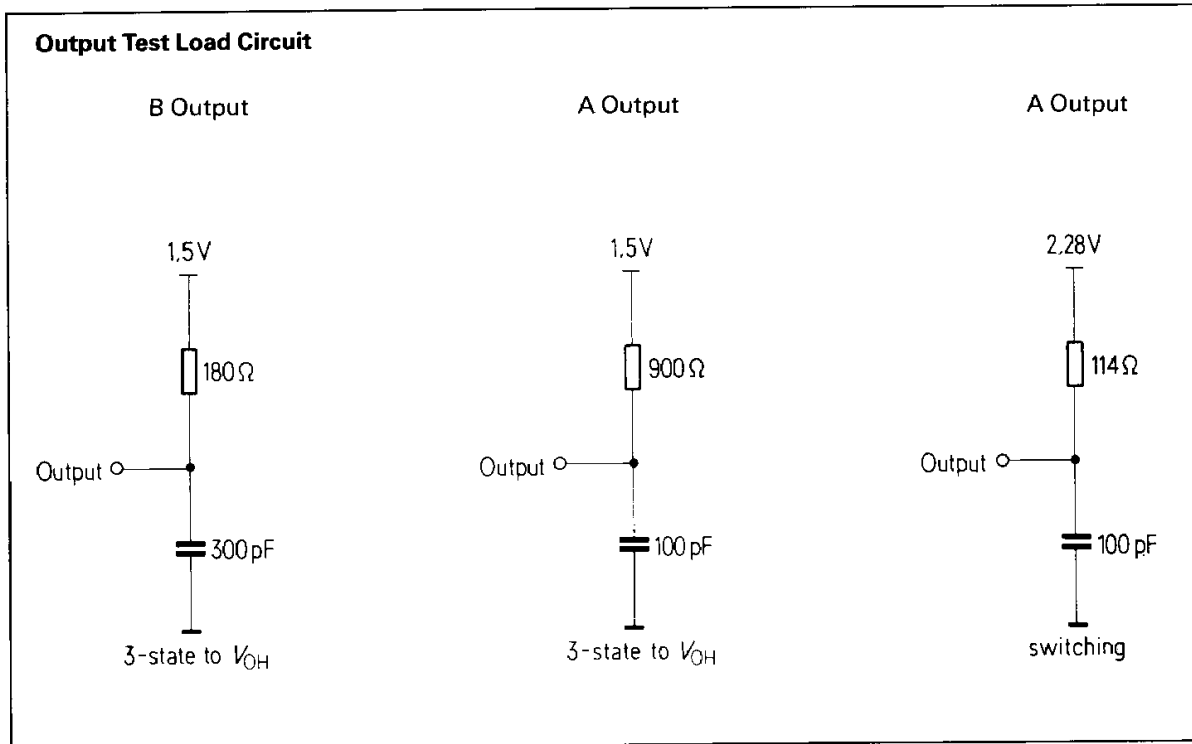

## Ordering Information

Type	Description	Ordering code
SAB 8286A-P	Octal Bus Transceiver, non inverting (plastic)	Q 67020-Y 153
SAB 8287A-P	Octal Bus Transceiver, inverting (plastic)	Q 67020-Y 154

This datasheet has been downloaded from:

[www.DatasheetCatalog.com](http://www.DatasheetCatalog.com)

Datasheets for electronic components.