



LPC1768/66/65/64

32-bit ARM Cortex-M3 microcontroller; up to 512 kB flash and 64 kB SRAM with Ethernet, USB 2.0 Host/Device/OTG, CAN

Rev. 02.06 — 18 August 2009

Preliminary data sheet

1. General description

The LPC1768/66/65/64 are ARM Cortex-M3 based microcontrollers for embedded applications featuring a high level of integration and low power consumption. The ARM Cortex-M3 is a next generation core that offers system enhancements such as enhanced debug features and a higher level of support block integration.

The LPC1768/66/65/64 operate at CPU frequencies of up to 100 MHz. The ARM Cortex-M3 CPU incorporates a 3-stage pipeline and uses a Harvard architecture with separate local instruction and data buses as well as a third bus for peripherals. The ARM Cortex-M3 CPU also includes an internal prefetch unit that supports speculative branching.

The peripheral complement of the LPC1768/66/65/64 includes up to 512 kB of flash memory, up to 64 kB of data memory, Ethernet MAC, USB Device/Host/OTG interface, 8-channel general purpose DMA controller, 4 UARTs, 2 CAN channels, 2 SSP controllers, SPI interface, 3 I²C-bus interfaces, 2-input plus 2-output I²S-bus interface, 8-channel 12-bit ADC, 10-bit DAC, motor control PWM, Quadrature Encoder interface, 4 general purpose timers, 6-output general purpose PWM, ultra-low power Real-Time Clock (RTC) with separate battery supply, and up to 70 general purpose I/O pins.

The LPC1768/66/65/64 are pin-compatible to the 100-pin LPC236x ARM7-based microcontroller series.

2. Features

- ARM Cortex-M3 processor, running at frequencies of up to 100 MHz. A Memory Protection Unit (MPU) supporting eight regions is included.
- ARM Cortex-M3 built-in Nested Vectored Interrupt Controller (NVIC).
- Up to 512 kB on-chip flash programming memory. Enhanced flash memory accelerator enables high-speed 100 MHz operation with zero wait states.
- In-System Programming (ISP) and In-Application Programming (IAP) via on-chip bootloader software.
- On-chip SRAM includes:
 - ◆ 32/16 kB of SRAM on the CPU with local code/data bus for high-performance CPU access.
 - ◆ Two/one 16 kB SRAM blocks with separate access paths for higher throughput. These SRAM blocks may be used for Ethernet (LPC1768/66/64 only), USB, and DMA memory, as well as for general purpose CPU instruction and data storage.

- Eight channel General Purpose DMA controller (GPDMA) on the AHB multilayer matrix that can be used with the SSP, I²S-bus, UART, the Analog-to-Digital and Digital-to-Analog converter peripherals, timer match signals, and for memory-to-memory transfers.
- Multilayer AHB matrix interconnect provides a separate bus for each AHB master. AHB masters include the CPU, General Purpose DMA controller, Ethernet MAC (LPC1768/66/64 only), and the USB interface. This interconnect provides communication with no arbitration delays.
- Split APB bus allows high throughput with few stalls between the CPU and DMA.
- Serial interfaces:
 - ◆ Ethernet MAC with RMII interface and dedicated DMA controller (LPC1768/66/64 only).
 - ◆ USB 2.0 full-speed device/Host/OTG controller with dedicated DMA controller and on-chip PHY for device, Host, and OTG functions. The LPC1764 includes a device controller only.
 - ◆ Four UARTs with fractional baud rate generation, internal FIFO, and DMA support. One UART has modem control I/O and RS-485/EIA-485 support, and one UART has IrDA support.
 - ◆ CAN 2.0B controller with two channels.
 - ◆ SPI controller with synchronous, serial, full duplex communication and programmable data length.
 - ◆ Two SSP controllers with FIFO and multi-protocol capabilities. The SSP interfaces can be used with the GPDMA controller.
 - ◆ Three enhanced I²C bus interfaces, one with an open-drain output supporting full I²C specification and Fast mode plus with data rates of 1Mbit/s, two with standard port pins. Enhancements include multiple address recognition and monitor mode.
 - ◆ On the LPC1768/66/65 only, I²S (Inter-IC Sound) interface for digital audio input or output, with fractional rate control. The I²S-bus interface can be used with the GPDMA. The I²S-bus interface supports 3-wire and 4-wire data transmit and receive as well as master clock input/output.
- Other peripherals:
 - ◆ 70 (100 pin package) General Purpose I/O (GPIO) pins with configurable pull-up/down resistors. All GPIOs support a new, configurable open-drain operating mode. The GPIO block is accessed through the AHB multilayer bus for fast access and located in memory such that it supports Cortex-M3 bit banding and use by the General Purpose DMA Controller.
 - ◆ 12-bit Analog-to-Digital Converter (ADC) with input multiplexing among eight pins, conversion rates up to 200 kHz, and multiple result registers. The 12-bit ADC can be used with the GPDMA controller.
 - ◆ 10-bit Digital-to-Analog Converter (DAC) with dedicated conversion timer and DMA support (LPC1768/66/65 only).
 - ◆ Four general purpose timers/counters, with a total of eight capture inputs and ten compare outputs. Each timer block has an external count input. Specific timer events can be selected to generate DMA requests.
 - ◆ One motor control PWM with support for three-phase motor control.
 - ◆ Quadrature encoder interface that can monitor one external quadrature encoder.
 - ◆ One standard PWM/timer block with external count input.

- ◆ RTC with a separate power domain and dedicated RTC oscillator. The RTC block includes 20 bytes of battery-powered backup registers.
- ◆ Watchdog Timer (WDT). The WDT can be clocked from the internal RC oscillator, the RTC oscillator, or the APB clock.
- ◆ ARM Cortex-M3 system tick timer, including an external clock input option.
- ◆ Repetitive interrupt timer provides programmable and repeating timed interrupts.
- ◆ Each peripheral has its own clock divider for further power savings.
- Standard JTAG test/debug interface for compatibility with existing tools. Serial Wire Debug and Serial Wire Trace Port options.
- Emulation trace module enables non-intrusive, high-speed real-time tracing of instruction execution.
- Integrated PMU (Power Management Unit) automatically adjusts internal regulators to minimize power consumption during Sleep, Deep sleep, Power-down, and Deep power-down modes.
- Four reduced power modes: Sleep, Deep-sleep, Power-down, and Deep power-down.
- Single 3.3 V power supply (2.4 V to 3.6 V).
- Four external interrupt inputs configurable as edge/level sensitive. All pins on PORT0 and PORT2 can be used as edge sensitive interrupt sources.
- Non-maskable Interrupt (NMI) input.
- Clock output function that can reflect the main oscillator clock, IRC clock, RTC clock, CPU clock, and the USB clock.
- The Wakeup Interrupt Controller (WIC) allows the CPU to automatically wake up from any priority interrupt that can occur while the clocks are stopped in deep sleep, Power-down, and Deep power-down modes.
- Processor wake-up from Power-down mode via any interrupt able to operate during Power-down mode (includes external interrupts, RTC interrupt, USB activity, Ethernet wake-up interrupt, CAN bus activity, PORT0/2 pin interrupt, and NMI).
- Brownout detect with separate threshold for interrupt and forced reset.
- Power-On Reset (POR).
- Crystal oscillator with an operating range of 1 MHz to 25 MHz.
- 4 MHz internal RC oscillator trimmed to 1 % accuracy that can optionally be used as a system clock.
- PLL allows CPU operation up to the maximum CPU rate without the need for a high-frequency crystal. May be run from the main oscillator, the internal RC oscillator, or the RTC oscillator.
- USB PLL for added flexibility.
- Code Read Protection (CRP) with different security levels.
- Available as 100-pin LQFP package (14 × 14 × 1.4 mm).

3. Applications

- eMetering
- Lighting
- Industrial networking
- Alarm systems
- White goods
- Motor control

4. Ordering information

Table 1. Ordering information

Type number	Package		
	Name	Description	Version
LPC1768FBD100	LQFP100	plastic low profile quad flat package; 100 leads; body 14 × 14 × 1.4 mm	SOT407-1
LPC1766FBD100	LQFP100	plastic low profile quad flat package; 100 leads; body 14 × 14 × 1.4 mm	SOT407-1
LPC1765FBD100	LQFP100	plastic low profile quad flat package; 100 leads; body 14 × 14 × 1.4 mm	SOT407-1
LPC1764FBD100	LQFP100	plastic low profile quad flat package; 100 leads; body 14 × 14 × 1.4 mm	SOT407-1

4.1 Ordering options

Table 2. Ordering options

Type number	Flash	Total SRAM	Ethernet	USB	CAN	I ² S	DAC	Package
LPC1768FBD100	512 kB	64 kB	yes	Device/Host/OTG	2	yes	yes	100 pins
LPC1766FBD100	256 kB	64 kB	yes	Device/Host/OTG	2	yes	yes	100 pins
LPC1765FBD100	256 kB	64 kB	no	Device/Host/OTG	2	yes	yes	100 pins
LPC1764FBD100	128 kB	32 kB	yes	Device only	2	no	no	100 pins

5. Block diagram

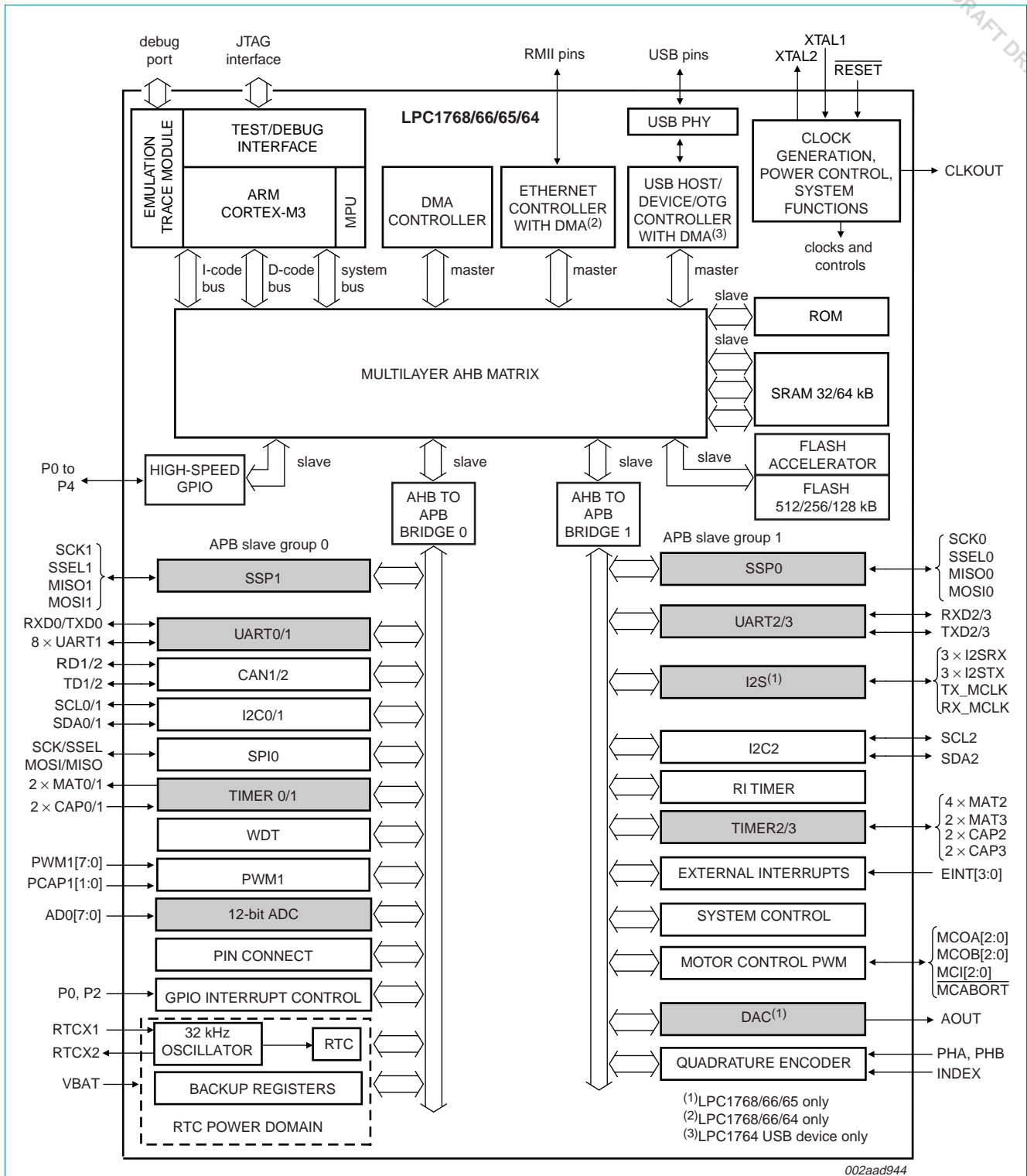

Grey-shaded blocks represent peripherals with connection to the GPDMA.

Fig 1. Block diagram

6. Pinning information

6.1 Pinning

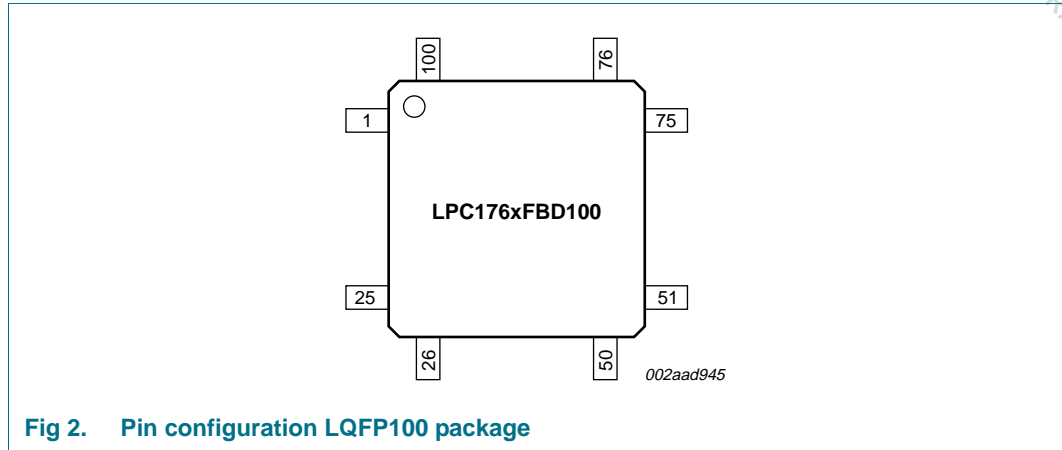

Fig 2. Pin configuration LQFP100 package

6.2 Pin description

Table 3. Pin description

Symbol	Pin	Type	Description
P0[0] to P0[31]		I/O	Port 0: Port 0 is a 32-bit I/O port with individual direction controls for each bit. The operation of port 0 pins depends upon the pin function selected via the pin connect block. Pins 12, 13, 14, and 31 of this port are not available.
P0[0]/RD1/TXD3/ SDA1	46 ^[1]	I/O	P0[0] — General purpose digital input/output pin.
		I	RD1 — CAN1 receiver input.
		O	TXD3 — Transmitter output for UART3.
		I/O	SDA1 — I ² C1 data input/output (this is not an I ² C-bus compliant open-drain pin).
P0[1]/TD1/RXD3/ SCL1	47 ^[1]	I/O	P0[1] — General purpose digital input/output pin.
		O	TD1 — CAN1 transmitter output.
		I	RXD3 — Receiver input for UART3.
		I/O	SCL1 — I ² C1 clock input/output (this is not an I ² C-bus compliant open-drain pin).
P0[2]/TXD0/AD0[7]	98 ^[2]	I/O	P0[2] — General purpose digital input/output pin.
		O	TXD0 — Transmitter output for UART0.
		I	AD0[7] — A/D converter 0, input 7.
P0[3]/RXD0/AD0[6]	99 ^[2]	I/O	P0[3] — General purpose digital input/output pin.
		I	RXD0 — Receiver input for UART0.
		I	AD0[6] — A/D converter 0, input 6.
P0[4]/ I2SRX_CLK/ RD2/CAP2[0]	81 ^[1]	I/O	P0[4] — General purpose digital input/output pin.
		I/O	I2SRX_CLK — Receive Clock. It is driven by the master and received by the slave. Corresponds to the signal SCK in the I ² S-bus specification. (LPC1768/66/65 only).
		I	RD2 — CAN2 receiver input.
		I	CAP2[0] — Capture input for Timer 2, channel 0.

Table 3. Pin description ...continued

Symbol	Pin	Type	Description
P0[5]/ I2SRX_WS/ TD2/CAP2[1]	80 ^[1]	I/O	P0[5] — General purpose digital input/output pin.
		I/O	I2SRX_WS — Receive Word Select. It is driven by the master and received by the slave. Corresponds to the signal WS in the <i>I²S-bus specification</i> . (LPC1768/66/65 only).
		O	TD2 — CAN2 transmitter output.
		I	CAP2[1] — Capture input for Timer 2, channel 1.
P0[6]/ I2SRX_SDA/ SSEL1/MAT2[0]	79 ^[1]	I/O	P0[6] — General purpose digital input/output pin.
		I/O	I2SRX_SDA — Receive data. It is driven by the transmitter and read by the receiver. Corresponds to the signal SD in the <i>I²S-bus specification</i> . (LPC1768/66/65 only).
		I/O	SSEL1 — Slave Select for SSP1.
		O	MAT2[0] — Match output for Timer 2, channel 0.
P0[7]/ I2STX_CLK/ SCK1/MAT2[1]	78 ^[1]	I/O	P0[7] — General purpose digital input/output pin.
		I/O	I2STX_CLK — Transmit Clock. It is driven by the master and received by the slave. Corresponds to the signal SCK in the <i>I²S-bus specification</i> . (LPC1768/66/65 only).
		I/O	SCK1 — Serial Clock for SSP1.
		O	MAT2[1] — Match output for Timer 2, channel 1.
P0[8]/ I2STX_WS/ MISO1/MAT2[2]	77 ^[1]	I/O	P0[8] — General purpose digital input/output pin.
		I/O	I2STX_WS — Transmit Word Select. It is driven by the master and received by the slave. Corresponds to the signal WS in the <i>I²S-bus specification</i> . (LPC1768/66/65 only).
		I/O	MISO1 — Master In Slave Out for SSP1.
		O	MAT2[2] — Match output for Timer 2, channel 2.
P0[9]/ I2STX_SDA/ MOSI1/MAT2[3]	76 ^[1]	I/O	P0[9] — General purpose digital input/output pin.
		I/O	I2STX_SDA — Transmit data. It is driven by the transmitter and read by the receiver. Corresponds to the signal SD in the <i>I²S-bus specification</i> . (LPC1768/66/65 only).
		I/O	MOSI1 — Master Out Slave In for SSP1.
		O	MAT2[3] — Match output for Timer 2, channel 3.
P0[10]/TXD2/ SDA2/MAT3[0]	48 ^[1]	I/O	P0[10] — General purpose digital input/output pin.
		O	TXD2 — Transmitter output for UART2.
		I/O	SDA2 — I ² C2 data input/output (this is not an open-drain pin).
		O	MAT3[0] — Match output for Timer 3, channel 0.
P0[11]/RXD2/ SCL2/MAT3[1]	49 ^[1]	I/O	P0[11] — General purpose digital input/output pin.
		I	RXD2 — Receiver input for UART2.
		I/O	SCL2 — I ² C2 clock input/output (this is not an open-drain pin).
		O	MAT3[1] — Match output for Timer 3, channel 1.
P0[15]/TXD1/ SCK0/SCK	62 ^[1]	I/O	P0[15] — General purpose digital input/output pin.
		O	TXD1 — Transmitter output for UART1.
		I/O	SCK0 — Serial clock for SSP0.
		I/O	SCK — Serial clock for SPI.

Table 3. Pin description ...continued

Symbol	Pin	Type	Description
P0[16]/RXD1/ SSEL0/SSEL	63 ^[1]	I/O	P0[16] — General purpose digital input/output pin.
		I	RXD1 — Receiver input for UART1.
		I/O	SSEL0 — Slave Select for SSP0.
		I/O	SSEL — Slave Select for SPI.
P0[17]/CTS1/ MISO0/MISO	61 ^[1]	I/O	P0[17] — General purpose digital input/output pin.
		I	CTS1 — Clear to Send input for UART1.
		I/O	MISO0 — Master In Slave Out for SSP0.
		I/O	MISO — Master In Slave Out for SPI.
P0[18]/DCD1/ MOSI0/MOSI	60 ^[1]	I/O	P0[18] — General purpose digital input/output pin.
		I	DCD1 — Data Carrier Detect input for UART1.
		I/O	MOSI0 — Master Out Slave In for SSP0.
		I/O	MOSI — Master Out Slave In for SPI.
P0[19]/DSR1/ SDA1	59 ^[1]	I/O	P0[19] — General purpose digital input/output pin.
		I	DSR1 — Data Set Ready input for UART1.
		I/O	SDA1 — I ² C1 data input/output (this is not an I ² C-bus compliant open-drain pin).
P0[20]/DTR1/SCL1	58 ^[1]	I/O	P0[20] — General purpose digital input/output pin.
		O	DTR1 — Data Terminal Ready output for UART1. Can also be configured to be an RS-485/EIA-485 output enable signal.
		I/O	SCL1 — I ² C1 clock input/output (this is not an I ² C-bus compliant open-drain pin).
P0[21]/RI1/RD1	57 ^[1]	I/O	P0[21] — General purpose digital input/output pin.
		I	RI1 — Ring Indicator input for UART1.
		I	RD1 — CAN1 receiver input.
P0[22]/RTS1/TD1	56 ^[1]	I/O	P0[22] — General purpose digital input/output pin.
		O	RTS1 — Request to Send output for UART1. Can also be configured to be an RS-485/EIA-485 output enable signal.
		O	TD1 — CAN1 transmitter output.
P0[23]/AD0[0]/ I2SRX_CLK/ CAP3[0]	9 ^[2]	I/O	P0[23] — General purpose digital input/output pin.
		I	AD0[0] — A/D converter 0, input 0.
		I/O	I2SRX_CLK — Receive Clock. It is driven by the master and received by the slave. Corresponds to the signal SCK in the <i>I²S-bus specification</i> . (LPC1768/66/65 only).
P0[24]/AD0[1]/ I2SRX_WS/ CAP3[1]	8 ^[2]	I	CAP3[0] — Capture input for Timer 3, channel 0.
		I/O	P0[24] — General purpose digital input/output pin.
		I	AD0[1] — A/D converter 0, input 1.
		I/O	I2SRX_WS — Receive Word Select. It is driven by the master and received by the slave. Corresponds to the signal WS in the <i>I²S-bus specification</i> . (LPC1768/66/65 only).
		I	CAP3[1] — Capture input for Timer 3, channel 1.

Table 3. Pin description ...continued

Symbol	Pin	Type	Description
P0[25]/AD0[2]/ I2SRX_SDA/ TXD3	7 ^[2]	I/O	P0[25] — General purpose digital input/output pin.
		I	AD0[2] — A/D converter 0, input 2.
		I/O	I2SRX_SDA — Receive data. It is driven by the transmitter and read by the receiver. Corresponds to the signal SD in the <i>I²S-bus specification</i> . (LPC1768/66/65 only).
		O	TXD3 — Transmitter output for UART3.
P0[26]/AD0[3]/ AOUT/RXD3	6 ^[3]	I/O	P0[26] — General purpose digital input/output pin.
		I	AD0[3] — A/D converter 0, input 3.
		O	AOUT — DAC output (LPC1768/66/65 only).
P0[27]/SDA0/ USB_SDA	25 ^[4]	I/O	P0[27] — General purpose digital input/output pin. Output is open-drain.
		I/O	SDA0 — I ² C0 data input/output. Open-drain output (for I ² C-bus compliance).
		I/O	USB_SDA — USB port I ² C serial data (OTG transceiver, LPC1768/66/65 only). (LPC1768/66/65 only).
P0[28]/SCL0/ USB_SCL	24 ^[4]	I/O	P0[28] — General purpose digital input/output pin. Output is open-drain.
		I/O	SCL0 — I ² C0 clock input/output. Open-drain output (for I ² C-bus compliance).
		I/O	USB_SCL — USB port I ² C serial clock (OTG transceiver, LPC1768/66/65 only).
P0[29]/USB_D+	29 ^[5]	I/O	P0[29] — General purpose digital input/output pin.
		I/O	USB_D+ — USB bidirectional D+ line.
P0[30]/USB_D-	30 ^[5]	I/O	P0[30] — General purpose digital input/output pin.
		I/O	USB_D- — USB bidirectional D- line.
P1[0] to P1[31]		I/O	Port 1: Port 1 is a 32-bit I/O port with individual direction controls for each bit. The operation of port 1 pins depends upon the pin function selected via the pin connect block. Pins 2, 3, 5, 6, 7, 11, 12, and 13 of this port are not available.
P1[0]/ ENET_TXD0	95 ^[1]	I/O	P1[0] — General purpose digital input/output pin.
		O	ENET_TXD0 — Ethernet transmit data 0. (LPC1768/66/64 only).
P1[1]/ ENET_TXD1	94 ^[1]	I/O	P1[1] — General purpose digital input/output pin.
		O	ENET_TXD1 — Ethernet transmit data 1. (LPC1768/66/64 only).
P1[4]/ ENET_TX_EN	93 ^[1]	I/O	P1[4] — General purpose digital input/output pin.
		O	ENET_TX_EN — Ethernet transmit data enable. (LPC1768/66/64 only).
P1[8]/ ENET_CRS	92 ^[1]	I/O	P1[8] — General purpose digital input/output pin.
		I	ENET_CRS — Ethernet carrier sense. (LPC1768/66/64 only).
P1[9]/ ENET_RXD0	91 ^[1]	I/O	P1[9] — General purpose digital input/output pin.
		I	ENET_RXD0 — Ethernet receive data. (LPC1768/66/64 only).
P1[10]/ ENET_RXD1	90 ^[1]	I/O	P1[10] — General purpose digital input/output pin.
		I	ENET_RXD1 — Ethernet receive data. (LPC1768/66/64 only).
P1[14]/ ENET_RX_ER	89 ^[1]	I/O	P1[14] — General purpose digital input/output pin.
		I	ENET_RX_ER — Ethernet receive error. (LPC1768/66/64 only).
P1[15]/ ENET_REF_CLK	88 ^[1]	I/O	P1[15] — General purpose digital input/output pin.
		I	ENET_REF_CLK — Ethernet reference clock. (LPC1768/66/64 only).
P1[16]/ ENET_MDC	87 ^[1]	I/O	P1[16] — General purpose digital input/output pin.
		O	ENET_MDC — Ethernet MIIM clock (LPC1768/66/64 only).

Table 3. Pin description ...continued

Symbol	Pin	Type	Description
P1[17]/ ENET_MDIO	86 ^[1]	I/O	P1[17] — General purpose digital input/output pin.
		I/O	ENET_MDIO — Ethernet MIIM data input and output. (LPC1768/66/64 only).
P1[18]/ USB_UP_LED/ PWM1[1]/ CAP1[0]	32 ^[1]	I/O	P1[18] — General purpose digital input/output pin.
		O	USB_UP_LED — USB GoodLink LED indicator. It is LOW when device is configured (non-control endpoints enabled). It is HIGH when the device is not configured or during global suspend.
		O	PWM1[1] — Pulse Width Modulator 1, channel 1 output.
		I	CAP1[0] — Capture input for Timer 1, channel 0.
P1[19]/MCOA0/ USB_PPWR CAP1[1]	33 ^[1]	I/O	P1[19] — General purpose digital input/output pin.
		O	MCOA0 — Motor control PWM channel 0, output A.
		O	USB_PPWR — Port Power enable signal for USB port (LPC1768/66/65 only).
		I	CAP1[1] — Capture input for Timer 1, channel 1.
P1[20]/MCI0/ PWM1[2]/SCK0	34 ^[1]	I/O	P1[20] — General purpose digital input/output pin.
		I	MCI0 — Motor control PWM channel 0, input. Also Quadrature Encoder Interface PHA input.
		O	PWM1[2] — Pulse Width Modulator 1, channel 2 output.
		I/O	SCK0 — Serial clock for SSP0.
P1[21]/MCABORT/ PWM1[3]/ SSEL0	35 ^[1]	I/O	P1[21] — General purpose digital input/output pin.
		O	MCABORT — Motor control PWM, LOW-active fast abort.
		O	PWM1[3] — Pulse Width Modulator 1, channel 3 output.
		I/O	SSEL0 — Slave Select for SSP0.
P1[22]/MCOB0/ USB_PWRD/ MAT1[0]	36 ^[1]	I/O	P1[22] — General purpose digital input/output pin.
		O	MCOB0 — Motor control PWM channel 0, output B.
		I	USB_PWRD — Power Status for USB port (host power switch, LPC1768/66/65 only).
		O	MAT1[0] — Match output for Timer 1, channel 0.
P1[23]/MCI1/ PWM1[4]/MISO0	37 ^[1]	I/O	P1[23] — General purpose digital input/output pin.
		I	MCI1 — Motor control PWM channel 1, input. Also Quadrature Encoder Interface PHB input.
		O	PWM1[4] — Pulse Width Modulator 1, channel 4 output.
		I/O	MISO0 — Master In Slave Out for SSP0.
P1[24]/MCI2/ PWM1[5]/MOSI0	38 ^[1]	I/O	P1[24] — General purpose digital input/output pin.
		I	MCI2 — Motor control PWM channel 2, input. Also Quadrature Encoder Interface INDEX input.
		O	PWM1[5] — Pulse Width Modulator 1, channel 5 output.
		I/O	MOSI0 — Master Out Slave in for SSP0.
P1[25]/MCOA1/ MAT1[1]	39 ^[1]	I/O	P1[25] — General purpose digital input/output pin.
		O	MCOA1 — Motor control PWM channel 1, output A.
		O	MAT1[1] — Match output for Timer 1, channel 1.

Table 3. Pin description ...continued

Symbol	Pin	Type	Description
P1[26]/MCOB1/ PWM1[6]/CAP0[0]	40 ^[1]	I/O	P1[26] — General purpose digital input/output pin.
		O	MCOB1 — Motor control PWM channel 1, output B.
		O	PWM1[6] — Pulse Width Modulator 1, channel 6 output.
		I	CAP0[0] — Capture input for Timer 0, channel 0.
P1[27]/CLKOUT /USB_OVRCR/ CAP0[1]	43 ^[1]	I/O	P1[27] — General purpose digital input/output pin.
		O	CLKOUT — Clock output pin.
		I	USB_OVRCR — USB port Over-Current status. (LPC1768/66/65 only).
		I	CAP0[1] — Capture input for Timer 0, channel 1.
P1[28]/MCOA2/ PCAP1[0]/ MAT0[0]	44 ^[1]	I/O	P1[28] — General purpose digital input/output pin.
		O	MCOA2 — Motor control PWM channel 2, output A.
		I	PCAP1[0] — Capture input for PWM1, channel 0.
		O	MAT0[0] — Match output for Timer 0, channel 0.
P1[29]/MCOB2/ PCAP1[1]/ MAT0[1]	45 ^[1]	I/O	P1[29] — General purpose digital input/output pin.
		O	MCOB2 — Motor control PWM channel 2, output B.
		I	PCAP1[1] — Capture input for PWM1, channel 1.
		O	MAT0[1] — Match output for Timer 0, channel 1.
P1[30]/V _{BUS} / AD0[4]	21 ^[2]	I/O	P1[30] — General purpose digital input/output pin.
		I	V_{BUS} — Monitors the presence of USB bus power. Note: This signal must be HIGH for USB reset to occur.
		I	AD0[4] — A/D converter 0, input 4.
P1[31]/SCK1/ AD0[5]	20 ^[2]	I/O	P1[31] — General purpose digital input/output pin.
		I/O	SCK1 — Serial Clock for SSP1.
		I	AD0[5] — A/D converter 0, input 5.
P2[0] to P2[31]		I/O	Port 2: Port 2 is a 32-bit I/O port with individual direction controls for each bit. The operation of port 2 pins depends upon the pin function selected via the pin connect block. Pins 14 through 31 of this port are not available.
P2[0]/PWM1[1]/ TXD1	75 ^[1]	I/O	P2[0] — General purpose digital input/output pin.
		O	PWM1[1] — Pulse Width Modulator 1, channel 1 output.
		O	TXD1 — Transmitter output for UART1.
P2[1]/PWM1[2]/ RXD1	74 ^[1]	I/O	P2[1] — General purpose digital input/output pin.
		O	PWM1[2] — Pulse Width Modulator 1, channel 2 output.
		I	RXD1 — Receiver input for UART1.
P2[2]/PWM1[3]/ CTS1/ TRACEDATA[3]	73 ^[1]	I/O	P2[2] — General purpose digital input/output pin.
		O	PWM1[3] — Pulse Width Modulator 1, channel 3 output.
		I	CTS1 — Clear to Send input for UART1.
		O	TRACEDATA[3] — Trace data, bit 3.
P2[3]/PWM1[4]/ DCD1/ TRACEDATA[2]	70 ^[1]	I/O	P2[3] — General purpose digital input/output pin.
		O	PWM1[4] — Pulse Width Modulator 1, channel 4 output.
		I	DCD1 — Data Carrier Detect input for UART1.
		O	TRACEDATA[2] — Trace data, bit 2.

Table 3. Pin description ...continued

Symbol	Pin	Type	Description
P2[4]/PWM1[5]/ DSR1/ TRACEDATA[1]	69 ^[1]	I/O	P2[4] — General purpose digital input/output pin.
		O	PWM1[5] — Pulse Width Modulator 1, channel 5 output.
		I	DSR1 — Data Set Ready input for UART1.
		O	TRACEDATA[1] — Trace data, bit 1.
P2[5]/PWM1[6]/ DTR1/ TRACEDATA[0]	68 ^[1]	I/O	P2[5] — General purpose digital input/output pin.
		O	PWM1[6] — Pulse Width Modulator 1, channel 6 output.
		O	DTR1 — Data Terminal Ready output for UART1. Can also be configured to be an RS-485/EIA-485 output enable signal.
		O	TRACEDATA[0] — Trace data, bit 0.
P2[6]/PCAP1[0]/ RI1/TRACECLK	67 ^[1]	I/O	P2[6] — General purpose digital input/output pin.
		I	PCAP1[0] — Capture input for PWM1, channel 0.
		I	RI1 — Ring Indicator input for UART1.
		O	TRACECLK — Trace Clock.
P2[7]/RD2/ RTS1	66 ^[1]	I/O	P2[7] — General purpose digital input/output pin.
		I	RD2 — CAN2 receiver input.
		O	RTS1 — Request to Send output for UART1. Can also be configured to be an RS-485/EIA-485 output enable signal.
P2[8]/TD2/ TXD2	65 ^[1]	I/O	P2[8] — General purpose digital input/output pin.
		O	TD2 — CAN2 transmitter output.
		O	TXD2 — Transmitter output for UART2.
P2[9]/ USB_CONNECT/ RXD2	64 ^[1]	I/O	P2[9] — General purpose digital input/output pin.
		O	USB_CONNECT — Signal used to switch an external 1.5 kΩ resistor under software control. Used with the SoftConnect USB feature.
		I	RXD2 — Receiver input for UART2.
P2[10]/ $\overline{\text{EINT0}}$ /NMI	53 ^[6]	I/O	P2[10] — General purpose digital input/output pin. Note: LOW on this pin while $\overline{\text{RESET}}$ is LOW forces on-chip bootloader to take over control of the part after a reset.
		I	$\overline{\text{EINT0}}$ — External interrupt 0 input.
		I	NMI — Non-maskable interrupt input.
P2[11]/ $\overline{\text{EINT1}}$ / I2STX_CLK	52 ^[6]	I/O	P2[11] — General purpose digital input/output pin.
		I	$\overline{\text{EINT1}}$ — External interrupt 1 input.
		I/O	I2STX_CLK — Transmit Clock. It is driven by the master and received by the slave. Corresponds to the signal SCK in the <i>I²S-bus specification</i> . (LPC1768/66/65 only).
P2[12]/ $\overline{\text{EINT2}}$ / I2STX_WS	51 ^[6]	I/O	P2[12] — General purpose digital input/output pin.
		I	$\overline{\text{EINT2}}$ — External interrupt 2 input.
		I/O	I2STX_WS — Transmit Word Select. It is driven by the master and received by the slave. Corresponds to the signal WS in the <i>I²S-bus specification</i> . (LPC1768/66/65 only).
P2[13]/ $\overline{\text{EINT3}}$ / I2STX_SDA	50 ^[6]	I/O	P2[13] — General purpose digital input/output pin.
		I	$\overline{\text{EINT3}}$ — External interrupt 3 input.
		I/O	I2STX_SDA — Transmit data. It is driven by the transmitter and read by the receiver. Corresponds to the signal SD in the <i>I²S-bus specification</i> . (LPC1768/66/65 only).

Table 3. Pin description ...continued

Symbol	Pin	Type	Description
P3[0] to P3[31]		I/O	Port 3: Port 3 is a 32-bit I/O port with individual direction controls for each bit. The operation of port 3 pins depends upon the pin function selected via the pin connect block. Pins 0 through 24, and 27 through 31 of this port are not available.
P3[25]/MAT0[0]/ PWM1[2]	27 ^[1]	I/O	P3[25] — General purpose digital input/output pin.
		O	MAT0[0] — Match output for Timer 0, channel 0.
		O	PWM1[2] — Pulse Width Modulator 1, output 2.
P3[26]/STCLK/ MAT0[1]/PWM1[3]	26 ^[1]	I/O	P3[26] — General purpose digital input/output pin.
		I	STCLK — System tick timer clock input.
		O	MAT0[1] — Match output for Timer 0, channel 1.
		O	PWM1[3] — Pulse Width Modulator 1, output 3.
P4[0] to P4[31]		I/O	Port 4: Port 4 is a 32-bit I/O port with individual direction controls for each bit. The operation of port 4 pins depends upon the pin function selected via the pin connect block. Pins 0 through 27, 30, and 31 of this port are not available.
P4[28]/RX_MCLK/ MAT2[0]/TXD3	82 ^[1]	I/O	P4[28] — General purpose digital input/output pin.
		I	RX_MCLK — I ² S receive master clock. (LPC1768/66/65 only).
		O	MAT2[0] — Match output for Timer 2, channel 0.
		O	TXD3 — Transmitter output for UART3.
P4[29]/TX_MCLK/ MAT2[1]/RXD3	85 ^[1]	I/O	P4[29] — General purpose digital input/output pin.
		I	TX_MCLK — I ² S transmit master clock. (LPC1768/66/65 only).
		O	MAT2[1] — Match output for Timer 2, channel 1.
		I	RXD3 — Receiver input for UART3.
TDO/SWO	1 ^[1]	O	TDO — Test Data out for JTAG interface.
		O	SWO — Serial wire trace output.
TDI	2 ^[1]	I	TDI — Test Data in for JTAG interface.
TMS/SWDIO	3 ^[1]	I	TMS — Test Mode Select for JTAG interface.
		I/O	SWDIO — Serial wire debug data input/output.
$\overline{\text{TRST}}$	4 ^[1]	I	$\overline{\text{TRST}}$ — Test Reset for JTAG interface.
TCK/SWDCLK	5 ^[1]	I	TCK — Test Clock for JTAG interface.
		I	SWDCLK — Serial wire clock.
RTCK	100 ^[1]	I/O	RTCK — JTAG interface control signal.
$\overline{\text{RSTOUT}}$	14	O	$\overline{\text{RSTOUT}}$ — This is a 3.3 V pin. LOW on this pin indicates LPC1768/66/65/64 being in Reset state.
$\overline{\text{RESET}}$	17 ^[7]	I	External reset input: A LOW on this pin resets the device, causing I/O ports and peripherals to take on their default states, and processor execution to begin at address 0. TTL with hysteresis, 5 V tolerant.
XTAL1	22 ^[8]	I	Input to the oscillator circuit and internal clock generator circuits.
XTAL2	23 ^[8]	O	Output from the oscillator amplifier.
RTCX1	16 ^[8]	I	Input to the RTC oscillator circuit.
RTCX2	18 ^[8]	O	Output from the RTC oscillator circuit.
V _{SS}	31, 41, 55, 72, 97, 83 ^[8]	I	ground: 0 V reference.

Table 3. Pin description ...continued

Symbol	Pin	Type	Description
V _{SSA}	11 ^[8]	I	analog ground: 0 V reference. This should nominally be the same voltage as V _{SS} , but should be isolated to minimize noise and error.
V _{DD(3V3)}	28, 54, 71, 96 ^[8]	I	3.3 V supply voltage: This is the power supply voltage for the I/O ports.
V _{DD(REG)(3V3)}	42, 84 ^[8]	I	3.3 V voltage regulator supply voltage: This is the supply voltage for the on-chip voltage regulator only.
V _{DDA}	10 ^[8]	I	analog 3.3 V pad supply voltage: This should be nominally the same voltage as V _{DD(3V3)} but should be isolated to minimize noise and error. This voltage is used to power the ADC and DAC. This pin should be tied to 3.3 V if the ADC and DAC are not used.
VREFP	12 ^[8]	I	ADC positive reference voltage: This should be nominally the same voltage as V _{DDA} but should be isolated to minimize noise and error. Level on this pin is used as a reference for ADC and DAC. This pin should be tied to 3.3 V if the ADC and DAC are not used.
VREFN	15	I	ADC negative reference voltage: This should be nominally the same voltage as V _{SS} but should be isolated to minimize noise and error. Level on this pin is used as a reference for ADC and DAC.
VBAT	19 ^[8]	I	RTC pin power supply: 3.3 V on this pin supplies the power to the RTC peripheral.
n.c.	13	-	not connected.

- [1] 5 V tolerant pad providing digital I/O functions with TTL levels and hysteresis.
- [2] 5 V tolerant pad providing digital I/O functions (with TTL levels and hysteresis) and analog input. When configured as a ADC input, digital section of the pad is disabled and the pin is not 5 V tolerant.
- [3] 5 V tolerant pad providing digital I/O with TTL levels and hysteresis and analog output function. When configured as the DAC output, digital section of the pad is disabled.
- [4] Open-drain 5 V tolerant digital I/O pad, compatible with I²C-bus 400 kHz specification. This pad requires an external pull-up to provide output functionality. When power is switched off, this pin connected to the I²C-bus is floating and does not disturb the I²C lines. Open-drain configuration applies to all functions on this pin.
- [5] Pad provides digital I/O and USB functions. It is designed in accordance with the *USB specification, revision 2.0* (Full-speed and Low-speed mode only).
- [6] 5 V tolerant pad with 5 ns glitch filter providing digital I/O functions with TTL levels and hysteresis.
- [7] 5 V tolerant pad with 20 ns glitch filter providing digital I/O function with TTL levels and hysteresis.
- [8] Pad provides special analog functionality.

7. Functional description

7.1 Architectural overview

The ARM Cortex-M3 includes three AHB-Lite buses: the system bus, the I-code bus, and the D-code bus (see [Figure 1](#)). The I-code and D-code core buses are faster than the system bus and are used similarly to TCM interfaces: one bus dedicated for instruction fetch (I-code) and one bus for data access (D-code). The use of two core buses allows for simultaneous operations if concurrent operations target different devices.

The LPC1768/66/65/64 use a multi-layer AHB matrix to connect the ARM Cortex-M3 buses and other bus masters to peripherals in a flexible manner that optimizes performance by allowing peripherals that are on different slaves ports of the matrix to be accessed simultaneously by different bus masters.

7.2 ARM Cortex-M3 processor

The ARM Cortex-M3 is a general purpose, 32-bit microprocessor, which offers high performance and very low power consumption. The ARM Cortex-M3 offers many new features, including a Thumb-2 instruction set, low interrupt latency, hardware divide, interruptable/continuable multiple load and store instructions, automatic state save and restore for interrupts, tightly integrated interrupt controller with wakeup interrupt controller, and multiple core buses capable of simultaneous accesses.

Pipeline techniques are employed so that all parts of the processing and memory systems can operate continuously. Typically, while one instruction is being executed, its successor is being decoded, and a third instruction is being fetched from memory.

The ARM Cortex-M3 processor is described in detail in the *Cortex-M3 Technical Reference Manual* that can be found on official ARM website.

7.3 On-chip flash program memory

The LPC1768/66/65/64 contain up to 512 kB of on-chip flash memory. A new two-port flash accelerator maximizes performance for use with the two fast AHB-Lite buses.

7.4 On-chip SRAM

The LPC1768/66/65/64 contain a total of 64 kB on-chip static RAM memory. This includes the main 32 kB SRAM, accessible by the CPU and DMA controller on a higher-speed bus, and two additional 16 kB each SRAM blocks situated on a separate slave port on the AHB multilayer matrix.

This architecture allows CPU and DMA accesses to be spread over three separate RAMs that can be accessed simultaneously.

7.5 Memory Protection Unit (MPU)

The LPC1768/66/65/64 have a Memory Protection Unit (MPU) which can be used to improve the reliability of an embedded system by protecting critical data within the user application.

The MPU allows separating processing tasks by disallowing access to each other's data, disabling access to memory regions, allowing memory regions to be defined as read-only and detecting unexpected memory accesses that could potentially break the system.

The MPU separates the memory into distinct regions and implements protection by preventing disallowed accesses. The MPU supports up to 8 regions each of which can be divided into 8 subregions. Accesses to memory locations that are not defined in the MPU regions, or not permitted by the region setting, will cause the Memory Management Fault exception to take place.

7.6 Memory map

The LPC17xx incorporates several distinct memory regions, shown in the following figures. [Figure 3](#) shows the overall map of the entire address space from the user program viewpoint following reset. The interrupt vector area supports address remapping.

The AHB peripheral area is 2 MB in size, and is divided to allow for up to 128 peripherals. The APB peripheral area is 1 MB in size and is divided to allow for up to 64 peripherals. Each peripheral of either type is allocated 16 kB of space. This allows simplifying the address decoding for each peripheral.

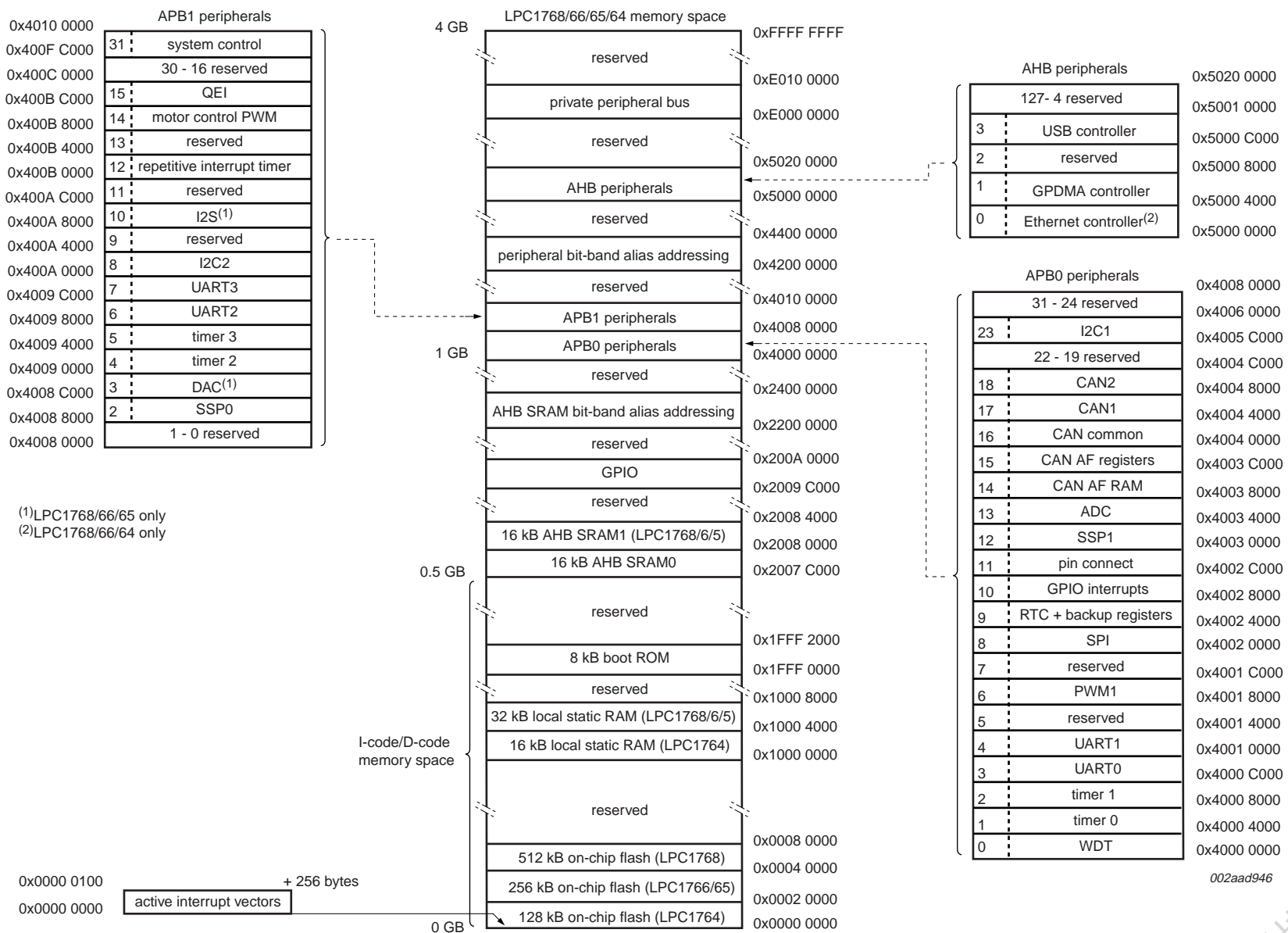

Fig 3. LPC1768/66/65/64 memory map

7.7 Nested Vectored Interrupt Controller (NVIC)

The NVIC is an integral part of the Cortex-M3. The tight coupling to the CPU allows for low interrupt latency and efficient processing of late arriving interrupts.

7.7.1 Features

- Controls system exceptions and peripheral interrupts
- In the LPC1768/66/65/64, the NVIC supports 33 vectored interrupts
- 32 programmable interrupt priority levels, with hardware priority level masking
- Relocatable vector table
- Non-Maskable Interrupt (NMI)
- Software interrupt generation

7.7.2 Interrupt sources

Each peripheral device has one interrupt line connected to the NVIC but may have several interrupt flags. Individual interrupt flags may also represent more than one interrupt source.

Any pin on PORT0 and PORT2 (total of 42 pins) regardless of the selected function, can be programmed to generate an interrupt on a rising edge, a falling edge, or both.

7.8 Pin connect block

The pin connect block allows selected pins of the microcontroller to have more than one function. Configuration registers control the multiplexers to allow connection between the pin and the on-chip peripherals.

Peripherals should be connected to the appropriate pins prior to being activated and prior to any related interrupt(s) being enabled. Activity of any enabled peripheral function that is not mapped to a related pin should be considered undefined.

Most pins can also be configured as open-drain outputs or to have a pull-up, pull-down, or no resistor enabled.

7.9 General purpose DMA controller

The GPDMA is an AMBA AHB compliant peripheral allowing selected LPC1768/66/65/64 peripherals to have DMA support.

The GPDMA enables peripheral-to-memory, memory-to-peripheral, peripheral-to-peripheral, and memory-to-memory transactions. The source and destination areas can each be either a memory region or a peripheral, and can be accessed through the AHB master. The GPDMA controller allows data transfers between the USB (LPC1768/66/65 only) and Ethernet controllers (LPC1768/66/64 only) and the various on-chip SRAM areas. The supported APB peripherals are SSP0/1, all UARTs, the I²S-bus interface, the ADC, and the DAC. Two match signals for each timer can be used to trigger DMA transfers. Note that the I²S-bus interface and the DAC are not available on the LPC1764.

7.9.1 Features

- Eight DMA channels. Each channel can support an unidirectional transfer.
- 16 DMA request lines.
- Single DMA and burst DMA request signals. Each peripheral connected to the DMA Controller can assert either a burst DMA request or a single DMA request. The DMA burst size is set by programming the DMA Controller.
- Memory-to-memory, memory-to-peripheral, peripheral-to-memory, and peripheral-to-peripheral transfers are supported.
- Scatter or gather DMA is supported through the use of linked lists. This means that the source and destination areas do not have to occupy contiguous areas of memory.
- Hardware DMA channel priority.
- AHB slave DMA programming interface. The DMA Controller is programmed by writing to the DMA control registers over the AHB slave interface.
- One AHB bus master for transferring data. The interface transfers data when a DMA request goes active.
- 32-bit AHB master bus width.
- Incrementing or non-incrementing addressing for source and destination.
- Programmable DMA burst size. The DMA burst size can be programmed to more efficiently transfer data.
- Internal four-word FIFO per channel.
- Supports 8, 16, and 32-bit wide transactions.
- Big-endian and little-endian support. The DMA Controller defaults to little-endian mode on reset.
- An interrupt to the processor can be generated on a DMA completion or when a DMA error has occurred.
- Raw interrupt status. The DMA error and DMA count raw interrupt status can be read prior to masking.

7.10 Fast general purpose parallel I/O

Device pins that are not connected to a specific peripheral function are controlled by the GPIO registers. Pins may be dynamically configured as inputs or outputs. Separate registers allow setting or clearing any number of outputs simultaneously. The value of the output register may be read back as well as the current state of the port pins.

LPC1768/66/65/64 use accelerated GPIO functions:

- GPIO registers are accessed through the AHB multilayer bus so that the fastest possible I/O timing can be achieved.
- Mask registers allow treating sets of port bits as a group, leaving other bits unchanged.
- All GPIO registers are byte and half-word addressable.
- Entire port value can be written in one instruction.
- Support for Cortex-M3 bit banding.
- Support for use with the GPDMA controller.

Additionally, any pin on PORT0 and PORT2 (total of 42 pins) providing a digital function can be programmed to generate an interrupt on a rising edge, a falling edge, or both. The edge detection is asynchronous, so it may operate when clocks are not present such as during Power-down mode. Each enabled interrupt can be used to wake up the chip from Power-down mode.

7.10.1 Features

- Bit level set and clear registers allow a single instruction to set or clear any number of bits in one port.
- Direction control of individual bits.
- All I/O default to inputs after reset.
- Pull-up/pull-down resistor configuration and open-drain configuration can be programmed through the pin connect block for each GPIO pin.

7.11 Ethernet (LPC1768/66/64 only)

Remark: The Ethernet controller is not available for part LPC1765.

The Ethernet block contains a full featured 10 Mbit/s or 100 Mbit/s Ethernet MAC designed to provide optimized performance through the use of DMA hardware acceleration. Features include a generous suite of control registers, half or full duplex operation, flow control, control frames, hardware acceleration for transmit retry, receive packet filtering and wake-up on LAN activity. Automatic frame transmission and reception with scatter-gather DMA off-loads many operations from the CPU.

The Ethernet block and the CPU share the ARM Cortex-M3 D-code and system bus through the AHB-multilayer matrix to access the various on-chip SRAM blocks for Ethernet data, control, and status information.

The Ethernet block interfaces between an off-chip Ethernet PHY using the Reduced MII (RMII) protocol and the on-chip Media Independent Interface Management (MIIM) serial bus.

The Ethernet block supports bus clock rates of up to 100 MHz.

7.11.1 Features

- Ethernet standards support:
 - Supports 10 Mbit/s or 100 Mbit/s PHY devices including 10 Base-T, 100 Base-TX, 100 Base-FX, and 100 Base-T4.
 - Fully compliant with *IEEE standard 802.3*.
 - Fully compliant with 802.3x full duplex flow control and half duplex back pressure.
 - Flexible transmit and receive frame options.
 - Virtual Local Area Network (VLAN) frame support.
- Memory management:
 - Independent transmit and receive buffers memory mapped to shared SRAM.
 - DMA managers with scatter/gather DMA and arrays of frame descriptors.
 - Memory traffic optimized by buffering and pre-fetching.

- Enhanced Ethernet features:
 - Receive filtering.
 - Multicast and broadcast frame support for both transmit and receive.
 - Optional automatic Frame Check Sequence (FCS) insertion with Cyclic Redundancy Check (CRC) for transmit.
 - Selectable automatic transmit frame padding.
 - Over-length frame support for both transmit and receive allows any length frames.
 - Promiscuous receive mode.
 - Automatic collision back-off and frame retransmission.
 - Includes power management by clock switching.
 - Wake-on-LAN power management support allows system wake-up: using the receive filters or a magic frame detection filter.
- Physical interface:
 - Attachment of external PHY chip through standard RMII interface.
 - PHY register access is available via the MIIM interface.

7.12 USB interface

The Universal Serial Bus (USB) is a 4-wire bus that supports communication between a host and one or more (up to 127) peripherals. The host controller allocates the USB bandwidth to attached devices through a token-based protocol. The bus supports hot plugging and dynamic configuration of the devices. All transactions are initiated by the host controller.

The LPC1768/66/65/64 USB interface includes a device, Host, and OTG controller with on-chip PHY for device and Host functions. The OTG switching protocol is supported through the use of an external controller. Details on typical USB interfacing solutions can be found in [Section 14.1](#).

Remark: The LPC1764 includes a device controller only.

7.12.1 USB device controller

The device controller enables 12 Mbit/s data exchange with a USB Host controller. It consists of a register interface, serial interface engine, endpoint buffer memory, and a DMA controller. The serial interface engine decodes the USB data stream and writes data to the appropriate endpoint buffer. The status of a completed USB transfer or error condition is indicated via status registers. An interrupt is also generated if enabled. When enabled, the DMA controller transfers data between the endpoint buffer and the on-chip SRAM.

7.12.1.1 Features

- Fully compliant with *USB 2.0 specification (full speed)*.
- Supports 32 physical (16 logical) endpoints with a 4 kB endpoint buffer RAM.
- Supports Control, Bulk, Interrupt and Isochronous endpoints.
- Scalable realization of endpoints at run time.

- Endpoint Maximum packet size selection (up to USB maximum specification) by software at run time.
- Supports SoftConnect and GoodLink features.
- While USB is in the Suspend mode, the LPC1768/66/65/64 can enter one of the reduced power modes and wake up on USB activity.
- Supports DMA transfers with all on-chip SRAM blocks on all non-control endpoints.
- Allows dynamic switching between CPU-controlled slave and DMA modes.
- Double buffer implementation for Bulk and Isochronous endpoints.

7.12.2 USB host controller (LPC1768/66/65 only)

The host controller enables full- and low-speed data exchange with USB devices attached to the bus. It consists of a register interface, a serial interface engine, and a DMA controller. The register interface complies with the OHCI specification.

7.12.2.1 Features

- OHCI compliant.
- One downstream port.
- Supports port power switching.

7.12.3 USB OTG controller (LPC1768/66/65 only)

USB OTG is a supplement to the USB 2.0 specification that augments the capability of existing mobile devices and USB peripherals by adding host functionality for connection to USB peripherals.

The OTG Controller integrates the host controller, device controller, and a master-only I²C-bus interface to implement OTG dual-role device functionality. The dedicated I²C-bus interface controls an external OTG transceiver.

7.12.3.1 Features

- Fully compliant with *On-The-Go supplement to the USB 2.0 Specification, Revision 1.0a*.
- Hardware support for Host Negotiation Protocol (HNP).
- Includes a programmable timer required for HNP and Session Request Protocol (SRP).
- Supports any OTG transceiver compliant with the *OTG Transceiver Specification (CEA-2011), Rev. 1.0*.

7.13 CAN controller and acceptance filters

The Controller Area Network (CAN) is a serial communications protocol which efficiently supports distributed real-time control with a very high level of security. Its domain of application ranges from high-speed networks to low cost multiplex wiring.

The CAN block is intended to support multiple CAN buses simultaneously, allowing the device to be used as a gateway, switch, or router among a number of CAN buses in industrial or automotive applications.

7.13.1 Features

- Two CAN controllers and buses.
- Data rates to 1 Mbit/s on each bus.
- 32-bit register and RAM access.
- Compatible with *CAN specification 2.0B, ISO 11898-1*.
- Global Acceptance Filter recognizes standard (11-bit) and extended-frame (29-bit) receive identifiers for all CAN buses.
- Acceptance Filter can provide FullCAN-style automatic reception for selected Standard Identifiers.
- FullCAN messages can generate interrupts.

7.14 12-bit ADC

The LPC1768/66/65/64 contain one ADC. It is a single 12-bit successive approximation ADC with eight channels and DMA support.

7.14.1 Features

- 12-bit successive approximation ADC.
- Input multiplexing among 8 pins.
- Power-down mode.
- Measurement range VREFN to VREFP.
- 12-bit conversion rate: 200 kHz.
- Individual channels can be selected for conversion.
- Burst conversion mode for single or multiple inputs.
- Optional conversion on transition of input pin or Timer Match signal.
- Individual result registers for each ADC channel to reduce interrupt overhead.
- DMA support.

7.15 10-bit DAC (LPC1768/66/65 only)

The DAC allows to generate a variable analog output. The maximum output value of the DAC is VREFP.

7.15.1 Features

- 10-bit DAC
- Resistor string architecture
- Buffered output
- Power-down mode
- Selectable output drive
- Dedicated conversion timer
- DMA support

7.16 UARTs

The LPC1768/66/65/64 each contain four UARTs. In addition to standard transmit and receive data lines, UART1 also provides a full modem control handshake interface and support for RS-485/9-bit mode allowing both software address detection and automatic address detection using 9-bit mode.

The UARTs include a fractional baud rate generator. Standard baud rates such as 115200 Bd can be achieved with any crystal frequency above 2 MHz.

7.16.1 Features

- Maximum UART data bit rate of 6.25 MBit/s.
- 16 B Receive and Transmit FIFOs.
- Register locations conform to 16C550 industry standard.
- Receiver FIFO trigger points at 1 B, 4 B, 8 B, and 14 B.
- Built-in fractional baud rate generator covering wide range of baud rates without a need for external crystals of particular values.
- Fractional divider for baud rate control, auto baud capabilities and FIFO control mechanism that enables software flow control implementation.
- UART1 equipped with standard modem interface signals. This module also provides full support for hardware flow control (auto-CTS/RTS).
- Support for RS-485/9-bit/EIA-485 mode (UART1).
- UART3 includes an IrDA mode to support infrared communication.
- All UARTs have DMA support.

7.17 SPI serial I/O controller

The LPC1768/66/65/64 contain one SPI controller. SPI is a full duplex serial interface designed to handle multiple masters and slaves connected to a given bus. Only a single master and a single slave can communicate on the interface during a given data transfer. During a data transfer the master always sends 8 bits to 16 bits of data to the slave, and the slave always sends 8 bits to 16 bits of data to the master.

7.17.1 Features

- Maximum SPI data bit rate of 12.5 Mbit/s
- Compliant with SPI specification
- Synchronous, serial, full duplex communication
- Combined SPI master and slave
- Maximum data bit rate of one eighth of the input clock rate
- 8 bits to 16 bits per transfer

7.18 SSP serial I/O controller

The LPC1768/66/65/64 contain two SSP controllers. The SSP controller is capable of operation on a SPI, 4-wire SSI, or Microwire bus. It can interact with multiple masters and slaves on the bus. Only a single master and a single slave can communicate on the bus

during a given data transfer. The SSP supports full duplex transfers, with frames of 4 bits to 16 bits of data flowing from the master to the slave and from the slave to the master. In practice, often only one of these data flows carries meaningful data.

7.18.1 Features

- Maximum SSP speed of 50 Mbit/s (master) or 8 Mbit/s (slave)
- Compatible with Motorola SPI, 4-wire Texas Instruments SSI, and National Semiconductor Microwire buses
- Synchronous serial communication
- Master or slave operation
- 8-frame FIFOs for both transmit and receive
- 4-bit to 16-bit frame
- DMA transfers supported by GPDMA

7.19 I²C-bus serial I/O controllers

The LPC1768/66/65/64 each contain three I²C-bus controllers.

The I²C-bus is bidirectional for inter-IC control using only two wires: a Serial Clock line (SCL) and a Serial Data Line (SDA). Each device is recognized by a unique address and can operate as either a receiver-only device (e.g., an LCD driver) or a transmitter with the capability to both receive and send information (such as memory). Transmitters and/or receivers can operate in either master or slave mode, depending on whether the chip has to initiate a data transfer or is only addressed. The I²C is a multi-master bus and can be controlled by more than one bus master connected to it.

7.19.1 Features

- I²C0 is a standard I²C compliant bus interface with open-drain pins. I²C0 also supports Fast mode plus with bit rates up to 1 Mbit/s.
- I²C1 and I²C2 use standard I/O pins with bit rates of up to 400 kbit/s (Fast I²C-bus).
- Easy to configure as master, slave, or master/slave.
- Programmable clocks allow versatile rate control.
- Bidirectional data transfer between masters and slaves.
- Multi-master bus (no central master).
- Arbitration between simultaneously transmitting masters without corruption of serial data on the bus.
- Serial clock synchronization allows devices with different bit rates to communicate via one serial bus.
- Serial clock synchronization can be used as a handshake mechanism to suspend and resume serial transfer.
- The I²C-bus can be used for test and diagnostic purposes.
- All I²C-bus controllers support multiple address recognition and a bus monitor mode.

7.20 I²S-bus serial I/O controllers

Remark: The I²S-bus is not available on the LPC1764.

The I²S-bus provides a standard communication interface for digital audio applications.

The *I²S-bus specification* defines a 3-wire serial bus using one data line, one clock line, and one word select signal. The basic I²S-bus connection has one master, which is always the master, and one slave. The I²S-bus interface on the LPC1768/66/65 provides a separate transmit and receive channel, each of which can operate as either a master or a slave.

7.20.1 Features

- The interface has separate input/output channels each of which can operate in master or slave mode.
- Capable of handling 8-bit, 16-bit, and 32-bit word sizes.
- Mono and stereo audio data supported.
- The sampling frequency can range from 16 kHz to 96 kHz (16, 22.05, 32, 44.1, 48, 96) kHz.
- Support for an audio master clock.
- Configurable word select period in master mode (separately for I²S-bus input and output).
- Two 8-word FIFO data buffers are provided, one for transmit and one for receive.
- Generates interrupt requests when buffer levels cross a programmable boundary.
- Two DMA requests, controlled by programmable buffer levels. These are connected to the GPDMA block.
- Controls include reset, stop and mute options separately for I²S-bus input and I²S-bus output.

7.21 General purpose 32-bit timers/external event counters

The LPC1768/66/65/64 include four 32-bit timer/counters. The timer/counter is designed to count cycles of the system derived clock or an externally-supplied clock. It can optionally generate interrupts, generate timed DMA requests, or perform other actions at specified timer values, based on four match registers. Each timer/counter also includes two capture inputs to trap the timer value when an input signal transitions, optionally generating an interrupt.

7.21.1 Features

- A 32-bit timer/counter with a programmable 32-bit prescaler.
- Counter or timer operation.
- Two 32-bit capture channels per timer, that can take a snapshot of the timer value when an input signal transitions. A capture event may also generate an interrupt.
- Four 32-bit match registers that allow:
 - Continuous operation with optional interrupt generation on match.
 - Stop timer on match with optional interrupt generation.
 - Reset timer on match with optional interrupt generation.
- Up to four external outputs corresponding to match registers, with the following capabilities:

- Set LOW on match.
 - Set HIGH on match.
 - Toggle on match.
 - Do nothing on match.
- Up to two match registers can be used to generate timed DMA requests.

7.22 Pulse width modulator

The PWM is based on the standard Timer block and inherits all of its features, although only the PWM function is pinned out on the LPC1768/66/65/64. The Timer is designed to count cycles of the system derived clock and optionally switch pins, generate interrupts or perform other actions when specified timer values occur, based on seven match registers. The PWM function is in addition to these features, and is based on match register events.

The ability to separately control rising and falling edge locations allows the PWM to be used for more applications. For instance, multi-phase motor control typically requires three non-overlapping PWM outputs with individual control of all three pulse widths and positions.

Two match registers can be used to provide a single edge controlled PWM output. One match register (PWMMR0) controls the PWM cycle rate, by resetting the count upon match. The other match register controls the PWM edge position. Additional single edge controlled PWM outputs require only one match register each, since the repetition rate is the same for all PWM outputs. Multiple single edge controlled PWM outputs will all have a rising edge at the beginning of each PWM cycle, when an PWMMR0 match occurs.

Three match registers can be used to provide a PWM output with both edges controlled. Again, the PWMMR0 match register controls the PWM cycle rate. The other match registers control the two PWM edge positions. Additional double edge controlled PWM outputs require only two match registers each, since the repetition rate is the same for all PWM outputs.

With double edge controlled PWM outputs, specific match registers control the rising and falling edge of the output. This allows both positive going PWM pulses (when the rising edge occurs prior to the falling edge), and negative going PWM pulses (when the falling edge occurs prior to the rising edge).

7.22.1 Features

- One PWM block with Counter or Timer operation (may use the peripheral clock or one of the capture inputs as the clock source).
- Seven match registers allow up to 6 single edge controlled or 3 double edge controlled PWM outputs, or a mix of both types. The match registers also allow:
 - Continuous operation with optional interrupt generation on match.
 - Stop timer on match with optional interrupt generation.
 - Reset timer on match with optional interrupt generation.

- Supports single edge controlled and/or double edge controlled PWM outputs. Single edge controlled PWM outputs all go high at the beginning of each cycle unless the output is a constant low. Double edge controlled PWM outputs can have either edge occur at any position within a cycle. This allows for both positive going and negative going pulses.
- Pulse period and width can be any number of timer counts. This allows complete flexibility in the trade-off between resolution and repetition rate. All PWM outputs will occur at the same repetition rate.
- Double edge controlled PWM outputs can be programmed to be either positive going or negative going pulses.
- Match register updates are synchronized with pulse outputs to prevent generation of erroneous pulses. Software must 'release' new match values before they can become effective.
- May be used as a standard 32-bit timer/counter with a programmable 32-bit prescaler if the PWM mode is not enabled.

7.23 Motor control PWM

The motor control PWM is a specialized PWM supporting 3-phase motors and other combinations. Feedback inputs are provided to automatically sense rotor position and use that information to ramp speed up or down. An abort input is also provided that causes the PWM to immediately release all motor drive outputs. At the same time, the motor control PWM is highly configurable for other generalized timing, counting, capture, and compare applications.

7.24 Quadrature Encoder Interface (QEI)

A quadrature encoder, also known as a 2-channel incremental encoder, converts angular displacement into two pulse signals. By monitoring both the number of pulses and the relative phase of the two signals, the user can track the position, direction of rotation, and velocity. In addition, a third channel, or index signal, can be used to reset the position counter. The quadrature encoder interface decodes the digital pulses from a quadrature encoder wheel to integrate position over time and determine direction of rotation. In addition, the QEI can capture the velocity of the encoder wheel.

7.24.1 Features

- Tracks encoder position.
- Increments/decrements depending on direction.
- Programmable for 2x or 4x position counting.
- Velocity capture using built-in timer.
- Velocity compare function with "less than" interrupt.
- Uses 32-bit registers for position and velocity.
- Three position compare registers with interrupts.
- Index counter for revolution counting.
- Index compare register with interrupts.
- Can combine index and position interrupts to produce an interrupt for whole and partial revolution displacement.

- Digital filter with programmable delays for encoder input signals.
- Can accept decoded signal inputs (clk and direction).
- Connected to APB.

7.25 Repetitive Interrupt (RI) timer

The repetitive interrupt timer provides a free-running 32-bit counter which is compared to a selectable value, generating an interrupt when a match occurs. Any bits of the timer/compare can be masked such that they do not contribute to the match detection. The repetitive interrupt timer can be used to create an interrupt that repeats at predetermined intervals.

7.25.1 Features

- 32-bit counter running from PCLK. Counter can be free-running or be reset by a generated interrupt.
- 32-bit compare value.
- 32-bit compare mask. An interrupt is generated when the counter value equals the compare value, after masking. This allows for combinations not possible with a simple compare.

7.26 ARM Cortex-M3 system tick timer

The ARM Cortex-M3 includes a system tick timer (SYSTICK) that is intended to generate a dedicated SYSTICK exception at a 10 ms interval. In the LPC1768/66/65/64, this timer can be clocked from the internal AHB clock or from a device pin.

7.27 Watchdog timer

The purpose of the watchdog is to reset the microcontroller within a reasonable amount of time if it enters an erroneous state. When enabled, the watchdog will generate a system reset if the user program fails to 'feed' (or reload) the watchdog within a predetermined amount of time.

7.27.1 Features

- Internally resets chip if not periodically reloaded.
- Debug mode.
- Enabled by software but requires a hardware reset or a watchdog reset/interrupt to be disabled.
- Incorrect/Incomplete feed sequence causes reset/interrupt if enabled.
- Flag to indicate watchdog reset.
- Programmable 32-bit timer with internal prescaler.
- Selectable time period from $(T_{cy(WDCLK)} \times 256 \times 4)$ to $(T_{cy(WDCLK)} \times 2^{32} \times 4)$ in multiples of $T_{cy(WDCLK)} \times 4$.
- The Watchdog Clock (WDCLK) source can be selected from the Internal RC (IRC) oscillator, the RTC oscillator, or the APB peripheral clock. This gives a wide range of potential timing choices of Watchdog operation under different power reduction

conditions. It also provides the ability to run the WDT from an entirely internal source that is not dependent on an external crystal and its associated components and wiring for increased reliability.

- Includes lock/safe feature.

7.28 RTC and backup registers

The RTC is a set of counters for measuring time when system power is on, and optionally when it is off. The RTC on the LPC1768/66/65/64 is designed to have extremely low power consumption, i.e. less than 1 μ A. The RTC will typically run from the main chip power supply, conserving battery power while the rest of the device is powered up. When operating from a battery, the RTC will continue working down to 2.1 V. Battery power can be provided from a standard 3 V Lithium button cell.

An ultra-low power 32 kHz oscillator will provide a 1 Hz clock to the time counting portion of the RTC, moving most of the power consumption out of the time counting function.

The RTC includes a calibration mechanism to allow fine-tuning the count rate in a way that will provide less than 1 second per day error when operated at a constant voltage and temperature. A clock output function (see [Section 7.29.4](#)) makes measuring the oscillator rate easy and accurate.

The RTC contains a small set of backup registers (20 bytes) for holding data while the main part of the LPC1768/66/65/64 is powered off.

The RTC includes an alarm function that can wake up the LPC1768/66/65/64 from all reduced power modes with a time resolution of 1 s.

7.28.1 Features

- Measures the passage of time to maintain a calendar and clock.
- Ultra low power design to support battery powered systems.
- Provides Seconds, Minutes, Hours, Day of Month, Month, Year, Day of Week, and Day of Year.
- Dedicated power supply pin can be connected to a battery or to the main 3.3 V.
- Periodic interrupts can be generated from increments of any field of the time registers.
- Backup registers (20 bytes) powered by VBAT.
- RTC power supply is isolated from the rest of the chip.

7.29 Clocking and power control

7.29.1 Crystal oscillators

The LPC1768/66/65/64 include three independent oscillators. These are the main oscillator, the IRC oscillator, and the RTC oscillator. Each oscillator can be used for more than one purpose as required in a particular application. Any of the three clock sources can be chosen by software to drive the main PLL and ultimately the CPU.

Following reset, the LPC1768/66/65/64 will operate from the Internal RC oscillator until switched by software. This allows systems to operate without any external crystal and the bootloader code to operate at a known frequency.

See [Figure 4](#) for an overview of the LPC1768/66/65/64 clock generation.

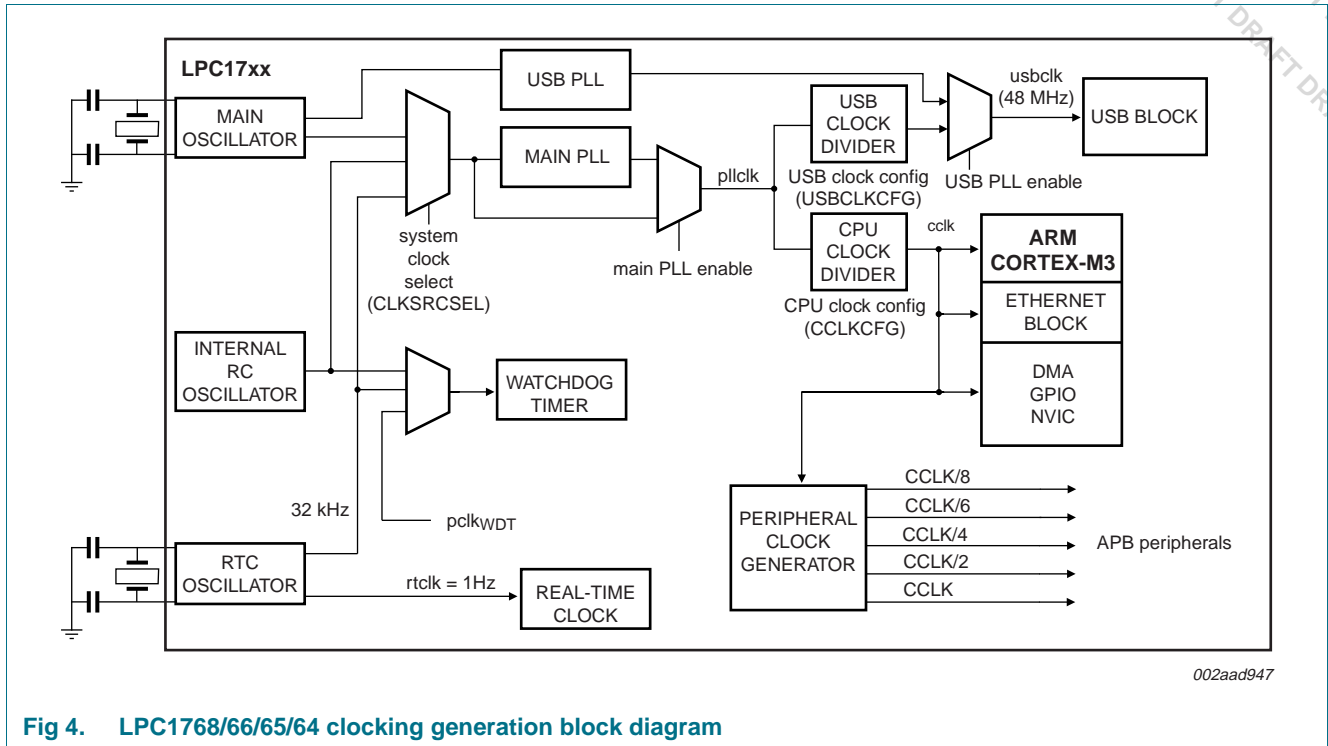

Fig 4. LPC1768/66/65/64 clocking generation block diagram

7.29.1.1 Internal RC oscillator

The IRC may be used as the clock source for the WDT, and/or as the clock that drives the PLL and subsequently the CPU. The nominal IRC frequency is 4 MHz. The IRC is trimmed to 1 % accuracy over the entire voltage and temperature range.

Upon power-up or any chip reset, the LPC1768/66/65/64 use the IRC as the clock source. Software may later switch to one of the other available clock sources.

7.29.1.2 Main oscillator

The main oscillator can be used as the clock source for the CPU, with or without using the PLL. The main oscillator also provides the clock source for the dedicated USB PLL.

The main oscillator operates at frequencies of 1 MHz to 25 MHz. This frequency can be boosted to a higher frequency, up to the maximum CPU operating frequency, by the main PLL. The clock selected as the PLL input is PLLCLKIN. The ARM processor clock frequency is referred to as CCLK elsewhere in this document. The frequencies of PLLCLKIN and CCLK are the same value unless the PLL is active and connected. The clock frequency for each peripheral can be selected individually and is referred to as PCLK. Refer to [Section 7.29.2](#) for additional information.

7.29.1.3 RTC oscillator

The RTC oscillator can be used as the clock source for the RTC block, the main PLL, and/or the CPU.

7.29.2 Main PLL (PLL0)

The PLL0 accepts an input clock frequency in the range of 32 kHz to 25 MHz. The input frequency is multiplied up to a high frequency, then divided down to provide the actual clock used by the CPU and/or the USB block.

The PLL0 input, in the range of 32 kHz to 25 MHz, may initially be divided down by a value 'N', which may be in the range of 1 to 256. This input division provides a wide range of output frequencies from the same input frequency.

Following the PLL0 input divider is the PLL0 multiplier. This can multiply the input divider output through the use of a Current Controlled Oscillator (CCO) by a value 'M', in the range of 1 through 32768. The resulting frequency must be in the range of 275 MHz to 550 MHz. The multiplier works by dividing the CCO output by the value of M, then using a phase-frequency detector to compare the divided CCO output to the multiplier input. The error value is used to adjust the CCO frequency.

The PLL0 is turned off and bypassed following a chip Reset and by entering Power-down mode. PLL0 is enabled by software only. The program must configure and activate the PLL0, wait for the PLL0 to lock, and then connect to the PLL0 as a clock source.

7.29.3 USB PLL (PLL1)

The LPC1768/66/65/64 contain a second, dedicated USB PLL1 to provide clocking for the USB interface.

The PLL1 receives its clock input from the main oscillator only and provides a fixed 48 MHz clock to the USB block only. The PLL1 is disabled and powered off on reset. If the PLL1 is left disabled, the USB clock will be supplied by the 48 MHz clock from the main PLL0.

The PLL1 accepts an input clock frequency in the range of 10 MHz to 25 MHz only. The input frequency is multiplied up the range of 48 MHz for the USB clock using a Current Controlled Oscillators (CCO). It is insured that the PLL1 output has a 50% duty cycle.

7.29.4 RTC clock output

The LPC1768/66/65/64 feature a clock output function intended for synchronizing with external devices and for use during system development to allow checking the internal clocks CCLK, IRC clock, main crystal, RTC clock, and USB clock in the outside world. The RTC clock output allows tuning the RTC frequency without probing the pin, which would distort the results.

7.29.5 Wake-up timer

The LPC1768/66/65/64 begin operation at power-up and when awakened from Power-down mode by using the 4 MHz IRC oscillator as the clock source. This allows chip operation to resume quickly. If the main oscillator or the PLL is needed by the application, software will need to enable these features and wait for them to stabilize before they are used as a clock source.

When the main oscillator is initially activated, the wake-up timer allows software to ensure that the main oscillator is fully functional before the processor uses it as a clock source and starts to execute instructions. This is important at power on, all types of Reset, and

whenever any of the aforementioned functions are turned off for any reason. Since the oscillator and other functions are turned off during Power-down mode, any wake-up of the processor from Power-down mode makes use of the wake-up Timer.

The Wake-up Timer monitors the crystal oscillator to check whether it is safe to begin code execution. When power is applied to the chip, or when some event caused the chip to exit Power-down mode, some time is required for the oscillator to produce a signal of sufficient amplitude to drive the clock logic. The amount of time depends on many factors, including the rate of $V_{DD(3V3)}$ ramp (in the case of power on), the type of crystal and its electrical characteristics (if a quartz crystal is used), as well as any other external circuitry (e.g., capacitors), and the characteristics of the oscillator itself under the existing ambient conditions.

7.29.6 Power control

The LPC1768/66/65/64 support a variety of power control features. There are four special modes of processor power reduction: Sleep mode, Deep-sleep mode, Power-down mode, and Deep power-down mode. The CPU clock rate may also be controlled as needed by changing clock sources, reconfiguring PLL values, and/or altering the CPU clock divider value. This allows a trade-off of power versus processing speed based on application requirements. In addition, Peripheral Power Control allows shutting down the clocks to individual on-chip peripherals, allowing fine tuning of power consumption by eliminating all dynamic power use in any peripherals that are not required for the application. Each of the peripherals has its own clock divider which provides even better power control.

Integrated PMU (Power Management Unit) automatically adjust internal regulators to minimize power consumption during Sleep, Deep sleep, Power-down, and Deep power-down modes.

The LPC1768/66/65/64 also implement a separate power domain to allow turning off power to the bulk of the device while maintaining operation of the RTC and a small set of registers for storing data during any of the power-down modes.

7.29.6.1 Sleep mode

When Sleep mode is entered, the clock to the core is stopped. Resumption from the Sleep mode does not need any special sequence but re-enabling the clock to the ARM core.

In Sleep mode, execution of instructions is suspended until either a Reset or interrupt occurs. Peripheral functions continue operation during Sleep mode and may generate interrupts to cause the processor to resume execution. Sleep mode eliminates dynamic power used by the processor itself, memory systems and related controllers, and internal buses.

7.29.6.2 Deep-sleep mode

In Deep-sleep mode, the oscillator is shut down and the chip receives no internal clocks. The processor state and registers, peripheral registers, and internal SRAM values are preserved throughout Deep-sleep mode and the logic levels of chip pins remain static. The output of the IRC is disabled but the IRC is not powered down for a fast wake-up later. The RTC oscillator is not stopped because the RTC interrupts may be used as the wake-up source. The PLL is automatically turned off and disconnected. The CCLK and USB clock dividers automatically get reset to zero.

The Deep-sleep mode can be terminated and normal operation resumed by either a Reset or certain specific interrupts that are able to function without clocks. Since all dynamic operation of the chip is suspended, Deep-sleep mode reduces chip power consumption to a very low value. Power to the flash memory is left on in Deep-sleep mode, allowing a very quick wake-up.

On wake-up from Deep-sleep mode, the code execution and peripherals activities will resume after 4 cycles expire if the IRC was used before entering Deep-sleep mode. If the main external oscillator was used, the code execution will resume when 4096 cycles expire. PLL and clock dividers need to be reconfigured accordingly.

7.29.6.3 Power-down mode

Power-down mode does everything that Deep-sleep mode does, but also turns off the power to the IRC oscillator and the flash memory. This saves more power but requires waiting for resumption of flash operation before execution of code or data access in the flash memory can be accomplished.

On the wake-up of Power-down mode, if the IRC was used before entering Power-down mode, it will take IRC 60 μ s to start-up. After this 4 IRC cycles will expire before the code execution can then be resumed if the code was running from SRAM. In the meantime, the flash wake-up timer then counts 4 MHz IRC clock cycles to make the 100 μ s flash start-up time. When it times out, access to the flash will be allowed. Users need to reconfigure the PLL and clock dividers accordingly.

7.29.6.4 Deep power-down mode

The Deep power-down mode can only be entered from the RTC block. In Deep power-down mode, power is shut off to the entire chip with the exception of the RTC module and the $\overline{\text{RESET}}$ pin.

The LPC1768/66/65/64 can wake up from Deep power-down mode via the $\overline{\text{RESET}}$ pin or an alarm match event of the RTC.

7.29.6.5 Wakeup interrupt controller

The Wakeup Interrupt Controller (WIC) allows the CPU to automatically wake up from any enabled priority interrupt that can occur while the clocks are stopped in Deep sleep, Power-down, and Deep power-down modes.

The WIC works in connection with the Nested Vectored Interrupt Controller (NVIC). When the CPU enters Deep sleep, Power-down, or Deep power-down mode, the NVIC sends a mask of the current interrupt situation to the WIC. This mask includes all of the interrupts that are both enabled and of sufficient priority to be serviced immediately. With this information, the WIC simply notices when one of the interrupts has occurred and then it wakes up the CPU.

The WIC eliminates the need to periodically wake up the CPU and poll the interrupts resulting in additional power savings.

7.29.7 Peripheral power control

A Power Control for Peripherals feature allows individual peripherals to be turned off if they are not needed in the application, resulting in additional power savings.

7.29.8 Power domains

The LPC1768/66/65/64 provide two independent power domains that allow the bulk of the device to have power removed while maintaining operation of the RTC and the backup Registers.

On the LPC1768/66/65/64, I/O pads are powered by the 3.3 V ($V_{DD(3V3)}$) pins, while the $V_{DD(REG)(3V3)}$ pin powers the on-chip voltage regulator which in turn provides power to the CPU and most of the peripherals.

Depending on the LPC1768/66/65/64 application, a design can use two power options to manage power consumption.

The first option assumes that power consumption is not a concern and the design ties the $V_{DD(3V3)}$ and $V_{DD(REG)(3V3)}$ pins together. This approach requires only one 3.3 V power supply for both pads, the CPU, and peripherals. While this solution is simple, it does not support powering down the I/O pad ring “on the fly” while keeping the CPU and peripherals alive.

The second option uses two power supplies; a 3.3 V supply for the I/O pads ($V_{DD(3V3)}$) and a dedicated 3.3 V supply for the CPU ($V_{DD(REG)(3V3)}$). Having the on-chip voltage regulator powered independently from the I/O pad ring enables shutting down of the I/O pad power supply “on the fly”, while the CPU and peripherals stay active.

The VBAT pin supplies power only to the RTC domain. The RTC requires a minimum of power to operate, which can be supplied by an external battery. The device core power ($V_{DD(REG)(3V3)}$) is used to operate the RTC whenever $V_{DD(REG)(3V3)}$ is present. Therefore, there is no power drain from the RTC battery when $V_{DD(REG)(3V3)}$ is available.

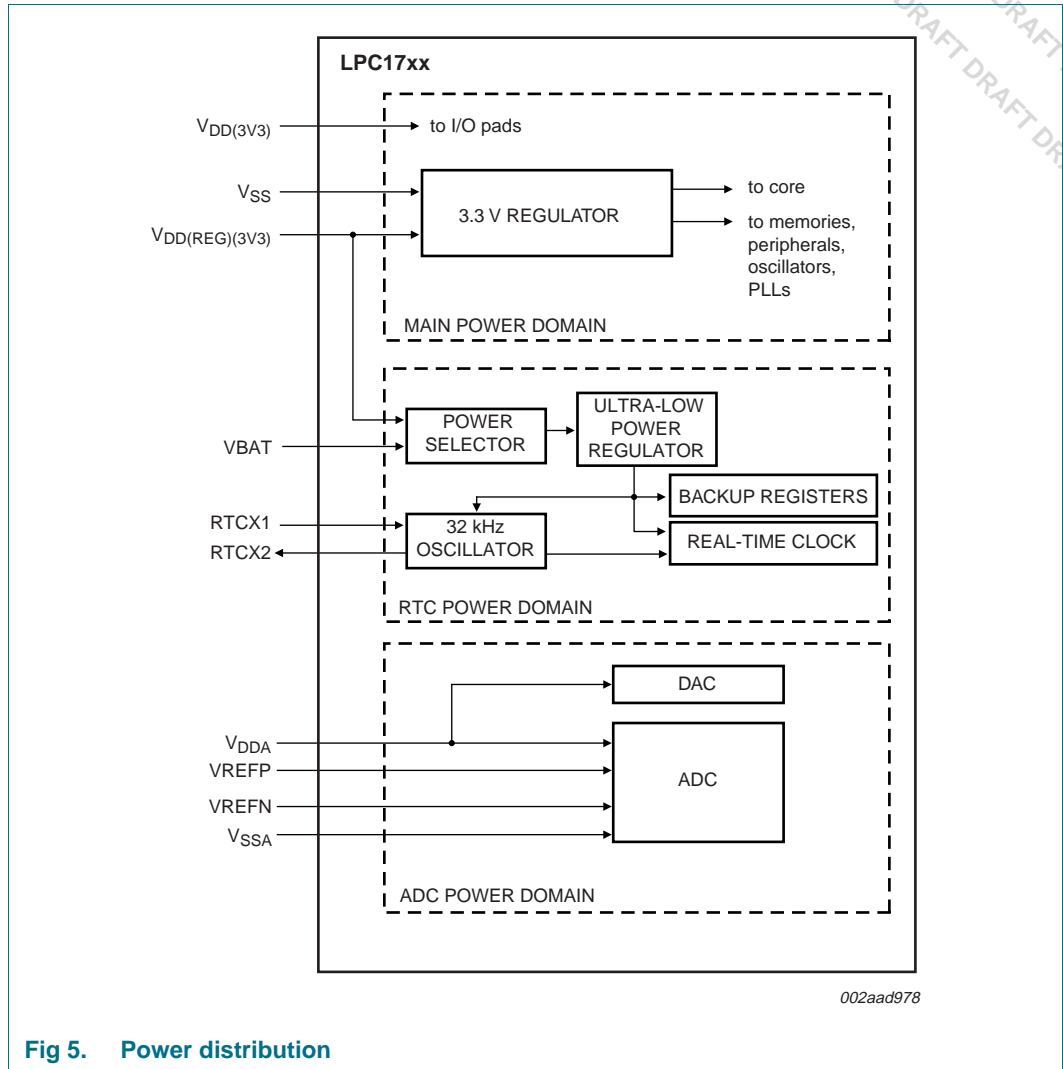

Fig 5. Power distribution

7.30 System control

7.30.1 Reset

Reset has four sources on the LPC1768/66/65/64: the $\overline{\text{RESET}}$ pin, the Watchdog reset, power-on reset (POR), and the BrownOut Detection (BOD) circuit. The $\overline{\text{RESET}}$ pin is a Schmitt trigger input pin. Assertion of chip Reset by any source, once the operating voltage attains a usable level, starts the Wake-up timer (see description in [Section 7.29.5](#)), causing reset to remain asserted until the external Reset is de-asserted, the oscillator is running, a fixed number of clocks have passed, and the flash controller has completed its initialization.

When the internal Reset is removed, the processor begins executing at address 0, which is initially the Reset vector mapped from the Boot Block. At that point, all of the processor and peripheral registers have been initialized to predetermined values.

7.30.2 Brownout detection

The LPC1768/66/65/64 include 2-stage monitoring of the voltage on the $V_{DD(REG)(3V3)}$ pins. If this voltage falls below 2.95 V, the BOD asserts an interrupt signal to the Vectored Interrupt Controller. This signal can be enabled for interrupt in the Interrupt Enable Register in the NVIC in order to cause a CPU interrupt; if not, software can monitor the signal by reading a dedicated status register.

The second stage of low-voltage detection asserts reset to inactivate the LPC1768/66/65/64 when the voltage on the $V_{DD(REG)(3V3)}$ pins falls below 2.65 V. This reset prevents alteration of the flash as operation of the various elements of the chip would otherwise become unreliable due to low voltage. The BOD circuit maintains this reset down below 1 V, at which point the power-on reset circuitry maintains the overall reset.

Both the 2.95 V and 2.65 V thresholds include some hysteresis. In normal operation, this hysteresis allows the 2.95 V detection to reliably interrupt, or a regularly executed event loop to sense the condition.

7.30.3 Code security (Code Read Protection - CRP)

This feature of the LPC1768/66/65/64 allows user to enable different levels of security in the system so that access to the on-chip flash and use of the JTAG and ISP can be restricted. When needed, CRP is invoked by programming a specific pattern into a dedicated flash location. IAP commands are not affected by the CRP.

There are three levels of the Code Read Protection.

CRP1 disables access to chip via the JTAG and allows partial flash update (excluding flash sector 0) using a limited set of the ISP commands. This mode is useful when CRP is required and flash field updates are needed but all sectors can not be erased.

CRP2 disables access to chip via the JTAG and only allows full flash erase and update using a reduced set of the ISP commands.

Running an application with level CRP3 selected fully disables any access to chip via the JTAG pins and the ISP. This mode effectively disables ISP override using P2[10] pin, too. It is up to the user's application to provide (if needed) flash update mechanism using IAP calls or call reinvoke ISP command to enable flash update via UART0.

CAUTION



If level three Code Read Protection (CRP3) is selected, no future factory testing can be performed on the device.

7.30.4 APB interface

The APB peripherals are split into two separate APB buses in order to distribute the bus bandwidth and thereby reducing stalls caused by contention between the CPU and the GPDMA controller.

7.30.5 AHB multilayer matrix

The LPC1768/66/65/64 use an AHB multilayer matrix. This matrix connects the instruction (I-code) and data (D-code) CPU buses of the ARM Cortex-M3 to the flash memory, the main (32KB) static RAM, and the Boot ROM. The GPDMA can also access all of these memories. The peripheral DMA controllers, Ethernet (LPC1768/66/64 only) and USB, can access all SRAM blocks. Additionally, the matrix connects the CPU system bus and all of the DMA controllers to the various peripheral functions.

7.30.6 External interrupt inputs

The LPC1768/66/65/64 include up to 46 edge sensitive interrupt inputs combined with up to four level sensitive external interrupt inputs as selectable pin functions. The external interrupt inputs can optionally be used to wake up the processor from Power-down mode.

7.30.7 Memory mapping control

The Cortex-M3 incorporates a mechanism that allows remapping the interrupt vector table to alternate locations in the memory map. This is controlled via the Vector Table Offset Register contained in the NVIC.

The vector table may be located anywhere within the bottom 1 GB of Cortex-M3 address space. The vector table must be located on a 128 word (512 byte) boundary because the NVIC on the LPC1768/66/65/64 is configured for 128 total interrupts.

7.31 Emulation and debugging

Debug and trace functions are integrated into the ARM Cortex-M3. Serial wire debug and trace functions are supported in addition to a standard JTAG debug and parallel trace functions. The ARM Cortex-M3 is configured to support up to eight breakpoints and four watch points.

8. Limiting values

Table 4. Limiting values

In accordance with the Absolute Maximum Rating System (IEC 60134).^[1]

Symbol	Parameter	Conditions	Min	Max	Unit
$V_{DD(3V3)}$	supply voltage (3.3 V)	core and external rail	2.4	3.6	V
$V_{DD(REG)(3V3)}$	regulator supply voltage (3.3 V)		2.4	3.6	V
V_{DDA}	analog 3.3 V pad supply voltage		-0.5	+4.6	V
$V_{i(VBAT)}$	input voltage on pin VBAT	for the RTC	-0.5	+4.6	V
$V_{i(VREFP)}$	input voltage on pin VREFP		-0.5	+4.6	V
V_{IA}	analog input voltage	on ADC related pins	-0.5	+5.1	V
V_I	input voltage	5 V tolerant I/O pins; only valid when the $V_{DD(3V3)}$ supply voltage is present	^[2] -0.5	+6.0	V
		other I/O pins	^{[2][3]} -0.5	$V_{DD(3V3)} + 0.5$	V
I_{DD}	supply current	per supply pin	^[4] -	100	mA
I_{SS}	ground current	per ground pin	^[4] -	100	mA
I_{latch}	I/O latch-up current	$-(0.5V_{DD(3V3)}) < V_I < (1.5V_{DD(3V3)})$; $T_j < 125\text{ }^\circ\text{C}$	-	100	mA
T_{stg}	storage temperature		^[5] -65	+150	$^\circ\text{C}$
$P_{tot(pack)}$	total power dissipation (per package)	based on package heat transfer, not device power consumption	-	1.5	W
V_{esd}	electrostatic discharge voltage	human body model; all pins	^[6] -4000	+4000	V

[1] The following applies to the limiting values:

- a) This product includes circuitry specifically designed for the protection of its internal devices from the damaging effects of excessive static charge. Nonetheless, it is suggested that conventional precautions be taken to avoid applying greater than the rated maximum.
- b) Parameters are valid over operating temperature range unless otherwise specified. All voltages are with respect to V_{SS} unless otherwise noted.

[2] Including voltage on outputs in 3-state mode.

[3] Not to exceed 4.6 V.

[4] The peak current is limited to 25 times the corresponding maximum current.

[5] Dependent on package type.

[6] Human body model: equivalent to discharging a 100 pF capacitor through a 1.5 k Ω series resistor.

9. Thermal characteristics

9.1 Thermal characteristics

The average chip junction temperature, T_j (°C), can be calculated using the following equation:

$$T_j = T_{amb} + (P_D \times R_{th(j-a)}) \tag{1}$$

- T_{amb} = ambient temperature (°C),
- $R_{th(j-a)}$ = the package junction-to-ambient thermal resistance (°C/W)
- P_D = sum of internal and I/O power dissipation

The internal power dissipation is the product of I_{DD} and V_{DD} . The I/O power dissipation of the I/O pins is often small and many times can be negligible. However it can be significant in some applications.

Table 5. Thermal characteristics

$V_{DD} = 2.4\text{ V to }3.6\text{ V}$; $T_{amb} = -40\text{ °C to }+85\text{ °C unless otherwise specified}$;

Symbol	Parameter	Conditions	Min	Typ	Max	Unit
$T_{j(max)}$	maximum junction temperature		-	-	125	°C

10. Static characteristics

Table 6. Static characteristics

$T_{amb} = -40\text{ }^{\circ}\text{C}$ to $+85\text{ }^{\circ}\text{C}$, unless otherwise specified.

Symbol	Parameter	Conditions	Min	Typ ^[1]	Max	Unit
Supply pins						
$V_{DD(3V3)}$	supply voltage (3.3 V)	core and external rail	2.4	3.3	3.6	V
$V_{DD(REG)(3V3)}$	regulator supply voltage (3.3 V)		2.4	3.3	3.6	V
V_{DDA}	analog 3.3 V pad supply voltage		2.7	3.3	3.6	V
$V_{i(VBAT)}$	input voltage on pin VBAT		[2] 2.1	3.3	3.6	V
$V_{i(VREFP)}$	input voltage on pin VREFP		2.7	3.3	V_{DDA}	V
$I_{DD(REG)(3V3)}$	regulator supply current (3.3 V)	active mode; code <code>while(1){</code>				
		executed from flash; all peripherals disabled; $PCLK = CCLK/8$				
		CCLK = 12 MHz; PLL disabled	[3] -	7	-	mA
		CCLK = 100 MHz; PLL enabled	[3] -	42	-	mA
		sleep mode	[3][4] -	2	-	mA
		deep sleep mode	[3][5] -	240	-	μA
		power-down mode	[3][5] -	31	-	μA
I_{BAT}	battery supply current	deep power-down mode; RTC running				
		$V_{DD(REG)(3V3)}$ present	[6] -	134	-	nA
		$V_{DD(REG)(3V3)}$ not present	[7] -	634	-	nA
$I_{DD(IO)}$	I/O supply current	deep sleep mode	[8] -	40	-	nA
		power-down mode	[8] -	40	-	nA
		deep power-down mode	[8] -	10	-	nA
$I_{DD(ADC)}$	ADC supply current	deep sleep mode	[9] -	38	-	nA
		power-down mode	[9] -	38	-	nA
		deep power-down mode	[9] -	24	-	nA
$I_{I(ADC)}$	ADC input current	on pin VREFP				
		deep sleep mode	[10] -	100	-	nA
		power-down mode	[10] -	100	-	nA
		deep power-down mode	[10] -	100	-	nA

Table 6. Static characteristics ...continued
T_{amb} = -40 °C to +85 °C, unless otherwise specified.

Symbol	Parameter	Conditions	Min	Typ ^[1]	Max	Unit
Standard port pins, RESET, RTCK						
I _{IL}	LOW-level input current	V _I = 0 V; on-chip pull-up resistor disabled	-	-	3	μA
I _{IH}	HIGH-level input current	V _I = V _{DD(3V3)} ; on-chip pull-down resistor disabled	-	-	3	μA
I _{OZ}	OFF-state output current	V _O = 0 V; V _O = V _{DD(3V3)} ; on-chip pull-up/down resistors disabled	-	-	3	μA
V _I	input voltage	pin configured to provide a digital function	[11][12][13] 0	-	5.5	V
V _O	output voltage	output active	0	-	V _{DD(3V3)}	V
V _{IH}	HIGH-level input voltage		2.0	-	-	V
V _{IL}	LOW-level input voltage		-	-	0.8	V
V _{hys}	hysteresis voltage		-	0.4	-	V
V _{OH}	HIGH-level output voltage	I _{OH} = -4 mA	[14] V _{DD(3V3)} - 0.4	-	-	V
V _{OL}	LOW-level output voltage	I _{OL} = 4 mA	[14] -	-	0.4	V
I _{OH}	HIGH-level output current	V _{OH} = V _{DD(3V3)} - 0.4 V	[14] -4	-	-	mA
I _{OL}	LOW-level output current	V _{OL} = 0.4 V	[14] 4	-	-	mA
I _{OHS}	HIGH-level short-circuit output current	V _{OH} = 0 V	[15] -	-	-45	mA
I _{OLS}	LOW-level short-circuit output current	V _{OL} = V _{DD(3V3)}	[15] -	-	50	mA
I _{pd}	pull-down current	V _I = 5 V	10	50	150	μA
I _{pu}	pull-up current	V _I = 0 V	-15	-50	-85	μA
		V _{DD(3V3)} < V _I < 5 V	0	0	0	μA
I²C-bus pins (P0[27] and P0[28])						
V _{IH}	HIGH-level input voltage		0.7V _{DD(3V3)}	-	-	V
V _{IL}	LOW-level input voltage		-	-	0.3V _{DD(3V3)}	V
V _{hys}	hysteresis voltage		-	0.5V _{DD(3V3)}	-	V
V _{OL}	LOW-level output voltage	I _{OLS} = 3 mA	[14] -	-	0.4	V
I _{LI}	input leakage current	V _I = V _{DD(3V3)}	[16] -	2	4	μA
		V _I = 5 V	-	10	22	μA
Oscillator pins						
V _{i(XTAL1)}	input voltage on pin XTAL1		0	1.8	1.95	V
V _{o(XTAL2)}	output voltage on pin XTAL2		0	1.8	1.95	V

Table 6. Static characteristics ...continued
T_{amb} = -40 °C to +85 °C, unless otherwise specified.

Symbol	Parameter	Conditions	Min	Typ ^[1]	Max	Unit
V _{i(RTCX1)}	input voltage on pin RTCX1		0	1.8	1.95	V
V _{o(RTCX2)}	output voltage on pin RTCX2		0	1.8	1.95	V
USB pins						
I _{OZ}	OFF-state output current	0 V < V _I < 3.3 V	-	-	±10	µA
V _{BUS}	bus supply voltage		-	-	5.25	V
V _{DI}	differential input sensitivity voltage	(D+) - (D-)	0.2	-	-	V
V _{CM}	differential common mode voltage range	includes V _{DI} range	0.8	-	2.5	V
V _{th(rs)se}	single-ended receiver switching threshold voltage		0.8	-	2.0	V
V _{OL}	LOW-level output voltage for low-/full-speed	R _L of 1.5 kΩ to 3.6 V	-	-	0.18	V
V _{OH}	HIGH-level output voltage (driven) for low-/full-speed	R _L of 15 kΩ to GND	2.8	-	3.5	V
C _{trans}	transceiver capacitance	pin to GND	-	-	20	pF
Z _{DRV}	driver output impedance for driver which is not high-speed capable	with 33 Ω series resistor; steady state drive	[17] 36	-	44.1	Ω

- [1] Typical ratings are not guaranteed. The values listed are at room temperature (25 °C), nominal supply voltages.
- [2] The RTC typically fails when V_{i(VBAT)} drops below 1.6 V.
- [3] V_{DD(REG)(3V3)} = 3.3 V; T_{amb} = 25 °C for all power consumption measurements.
- [4] IRC running at 4 MHz; main oscillator and PLL disabled; PCLK = CCLK₈.
- [5] BOD disabled.
- [6] On pin VBAT; I_{DD(REG)(3V3)} = 520 nA; V_{DD(REG)(3V3)} = 3.3 V; V_{BAT} = 3.3 V; T_{amb} = 25 °C.
- [7] On pin VBAT; V_{BAT} = 3.3 V; T_{amb} = 25 °C.
- [8] All internal pull-ups disabled. All pins configured as output and driven LOW. V_{DD(3V3)} = 3.3 V; T_{amb} = 25 °C.
- [9] V_{DDA} = 3.3 V; T_{amb} = 25 °C.
- [10] V_{i(VREFF)} = 3.3 V; T_{amb} = 25 °C.
- [11] Including voltage on outputs in 3-state mode.
- [12] V_{DD(3V3)} supply voltages must be present.
- [13] 3-state outputs go into 3-state mode when V_{DD(3V3)} is grounded.
- [14] Accounts for 100 mV voltage drop in all supply lines.
- [15] Allowed as long as the current limit does not exceed the maximum current allowed by the device.
- [16] To V_{SS}.
- [17] Includes external resistors of 33 Ω ± 1 % on D+ and D-.

11. Dynamic characteristics

11.1 Flash memory

Table 7. Flash characteristics

$T_{amb} = -40\text{ °C to }+85\text{ °C}$, unless otherwise specified.

Symbol	Parameter	Conditions	Min	Typ	Max	Unit
N_{endu}	endurance		[1] 10000	-	-	cycles
t_{ret}	retention time	powered	10	-	-	years
		unpowered	20	-	-	years

[1] Number of program/erase cycles.

11.2 External clock

Table 8. Dynamic characteristic: external clock

$T_{amb} = -40\text{ °C to }+85\text{ °C}$; $V_{DD(3V3)}$ over specified ranges.[1]

Symbol	Parameter	Conditions	Min	Typ[2]	Max	Unit
f_{osc}	oscillator frequency		1	-	25	MHz
$T_{cy(clk)}$	clock cycle time		40	-	1000	ns
t_{CHCX}	clock HIGH time		$T_{cy(clk)} \times 0.4$	-	-	ns
t_{CLCX}	clock LOW time		$T_{cy(clk)} \times 0.4$	-	-	ns
t_{CLCH}	clock rise time		-	-	5	ns
t_{CHCL}	clock fall time		-	-	5	ns

[1] Parameters are valid over operating temperature range unless otherwise specified.

[2] Typical ratings are not guaranteed. The values listed are at room temperature (25 °C), nominal supply voltages.

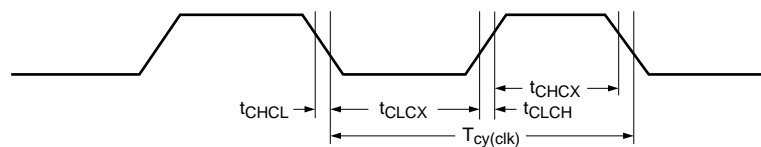

002aaa907

Fig 6. External clock timing (with an amplitude of at least $V_{i(RMS)} = 200\text{ mV}$)

11.3 Internal oscillators

Table 9. Dynamic characteristic: internal oscillators

$T_{amb} = -40\text{ }^{\circ}\text{C to } +85\text{ }^{\circ}\text{C}; 2.7\text{ V} \leq V_{DD(3V3)} \leq 3.6\text{ V}$.^[1]

Symbol	Parameter	Conditions	Min	Typ ^[2]	Max	Unit
$f_{osc(RC)}$	internal RC oscillator frequency	-	3.96	4.00	4.04	MHz
$f_i(RTC)$	RTC input frequency	-	-	32.768	-	kHz

- [1] Parameters are valid over operating temperature range unless otherwise specified.
- [2] Typical ratings are not guaranteed. The values listed are at room temperature (25 °C), nominal supply voltages.

11.4 I²C-bus

Table 10. Dynamic characteristic: I²C-bus pins (Fast-mode Plus)

$T_{amb} = -40\text{ }^{\circ}\text{C to } +85\text{ }^{\circ}\text{C}; V_{DD(3V3)}$ over specified ranges.^[1]

Symbol	Parameter	Conditions	Min	Typ ^{[2][3]}	Max	Unit
f_{SCL}	SCL clock frequency	-	-	-	1	MHz
$t_{f(o)}$	output fall time	V_{IH} to V_{IL}	$20 + 0.1 \times C_b$ ^[4]	-	-	ns
t_r	rise time	-	<td>	27	<td>	ns
t_f	fall time	-	<td>	39	<td>	ns
t_{LOW}	LOW period of the SCL clock	-	<td>	541	<td>	ns
t_{HIGH}	HIGH period of the SCL clock	-	<td>	375	<td>	ns
$t_{SU,DAT}$	data set-up time	-	<td>	23	<td>	ns

- [1] Parameters are valid over operating temperature range unless otherwise specified.
- [2] Typical ratings are not guaranteed. The values listed are at room temperature (25 °C), nominal supply voltages.
- [3] CCLK = PCLK = 20 MHz; I²C-bus interface configured in master transmitter mode.
- [4] Bus capacitance C_b in pF, from 10 pF to 400 pF.

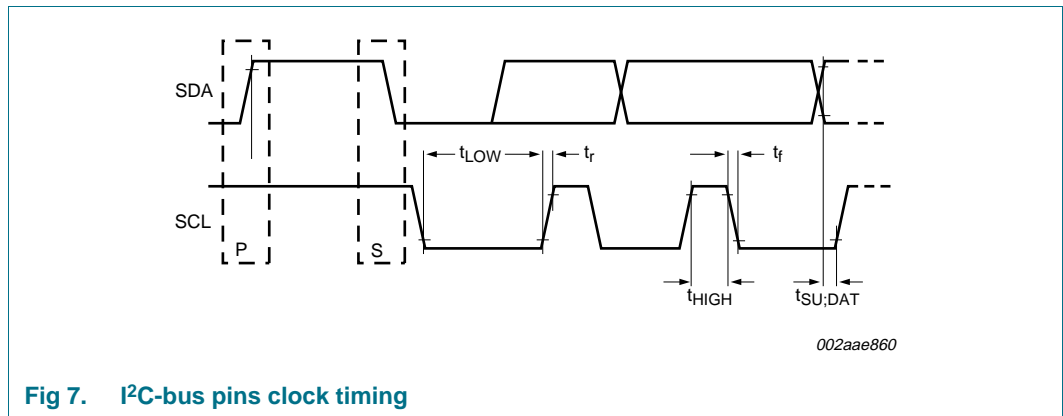

Fig 7. I²C-bus pins clock timing

11.5 I²S-bus interface

Table 11. Dynamic characteristics: I²S-bus interface pins

T_{amb} = -40 °C to +85 °C.

Symbol	Parameter	Conditions	Min	Typ	Max	Unit
common to input and output						
T _{cy(clk)}	clock cycle time		<td>	<td>	<td>	<td>
t _r	rise time		[1]	-	35	ns
t _f	fall time		[1]	-	35	ns
t _{WH}	pulse width HIGH	on pins I2STX_CLK and I2SRX_CLK	[1]	0.495 × T _{cy(clk)}	-	-
t _{WL}	pulse width LOW	on pins I2STX_CLK and I2SRX_CLK	[1]	-	-	0.505 × T _{cy(clk)} ns
output						
t _{v(Q)}	data output valid time	on pin I2STX_SDA;	[1]	-	30	ns
		on pin I2STX_WS	[1]	-	30	ns
input						
t _{su(D)}	data input set-up time	on pin I2SRX_SDA	[1]	3.5	-	ns
t _{h(D)}	data input hold time	on pin I2SRX_SDA	[1]	<td>	<td>	<td>

[1] CCLK = 20 MHz; peripheral clock to the I²S-bus interface PCLK = CCLK/4; I²S clock cycle time T_{cy(clk)} = 1600 ns, corresponds to the SCK signal in the I²S-bus specification;

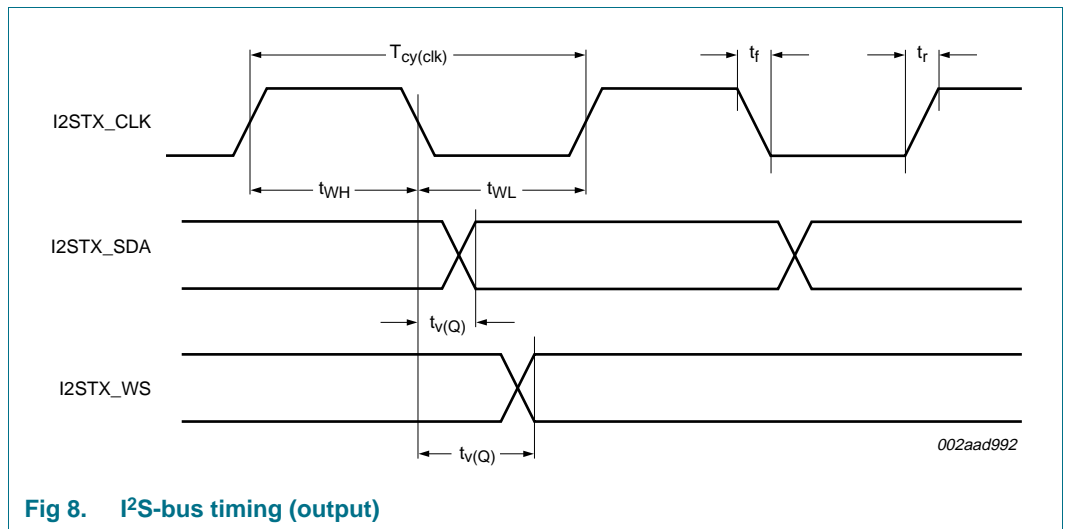

Fig 8. I²S-bus timing (output)

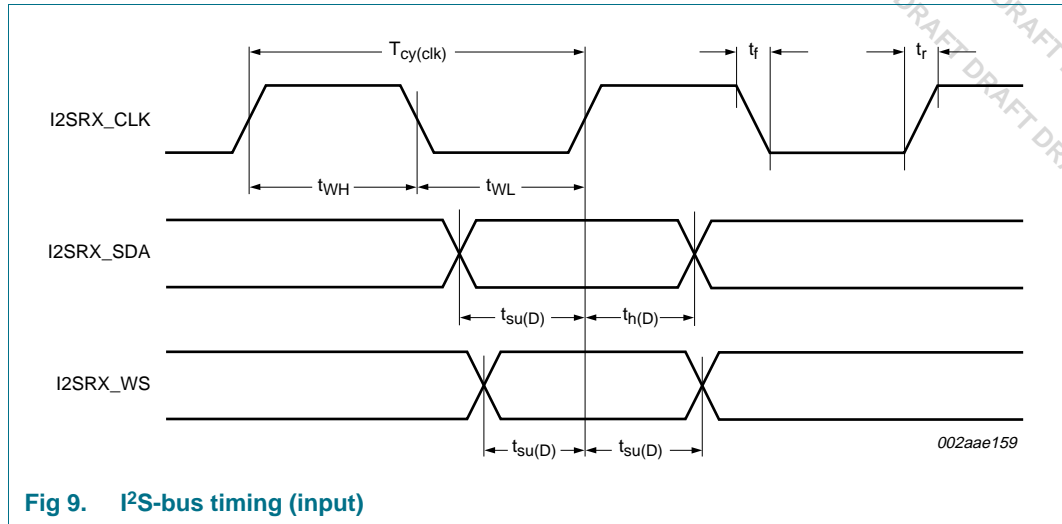

Fig 9. I2S-bus timing (input)

11.6 SSP interface

Table 12. Dynamic characteristic: SSP interface

$T_{amb} = 25\text{ }^{\circ}\text{C}$; $V_{DD(3V3)}$ over specified ranges.

Symbol	Parameter	Conditions	Min	Typ	Max	Unit
SSP interface						
$t_{su(SPI_MISO)}$	SPI_MISO set-up time	measured in SPI Master mode; see Figure 10	[1]	30	-	ns

[1] The peripheral clock for SSP is PCLK = CCLK = 20 MHz.

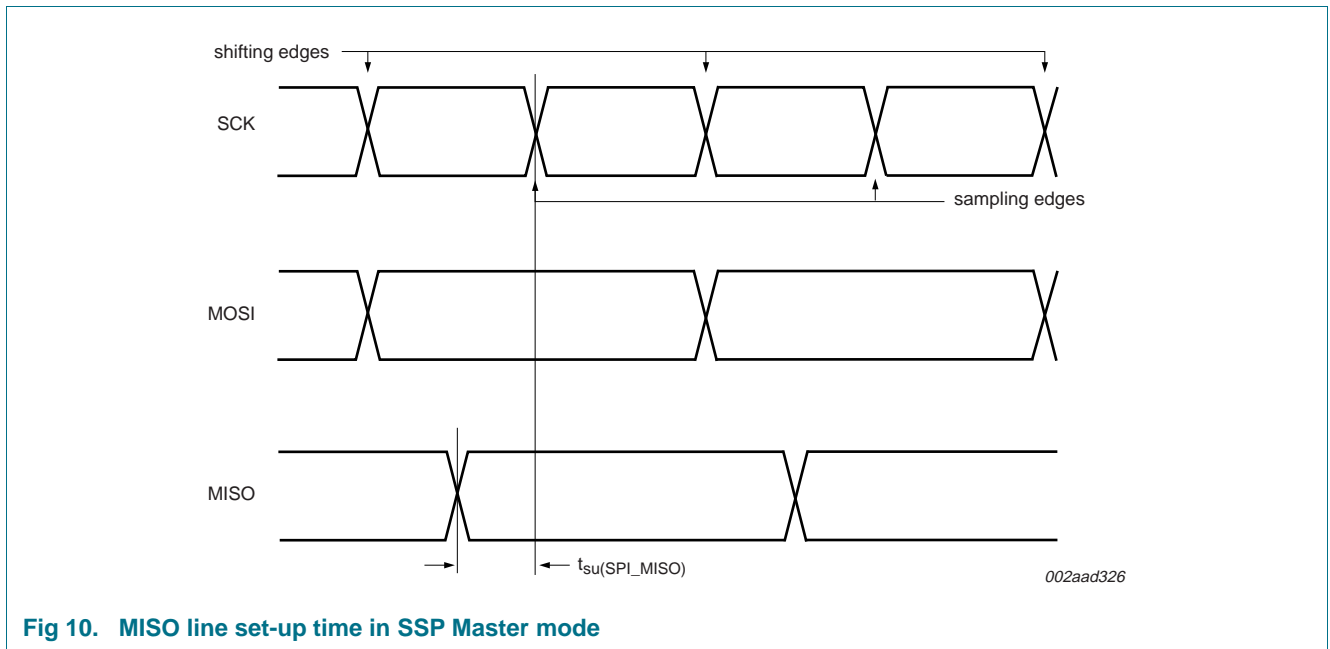

Fig 10. MISO line set-up time in SSP Master mode

11.7 USB interface

Table 13. Dynamic characteristics: USB pins (full-speed)

$C_L = 50\text{ pF}$; $R_{pu} = 1.5\text{ k}\Omega$ on $D+$ to $V_{DD(3V3)}$, unless otherwise specified.

Symbol	Parameter	Conditions	Min	Typ	Max	Unit
t_r	rise time	10 % to 90 %	8.5	-	13.8	ns
t_f	fall time	10 % to 90 %	7.7	-	13.7	ns
t_{FRFM}	differential rise and fall time matching	t_r / t_f	-	-	109	%
V_{CRS}	output signal crossover voltage		1.3	-	2.0	V
t_{FEOPT}	source SE0 interval of EOP	see Figure 11	160	-	175	ns
t_{FDEOP}	source jitter for differential transition to SE0 transition	see Figure 11	-2	-	+5	ns
t_{JR1}	receiver jitter to next transition		-18.5	-	+18.5	ns
t_{JR2}	receiver jitter for paired transitions	10 % to 90 %	-9	-	+9	ns
t_{EOPR1}	EOP width at receiver	must reject as EOP; see Figure 11	[1] 40	-	-	ns
t_{EOPR2}	EOP width at receiver	must accept as EOP; see Figure 11	[1] 82	-	-	ns

[1] Characterized but not implemented as production test. Guaranteed by design.

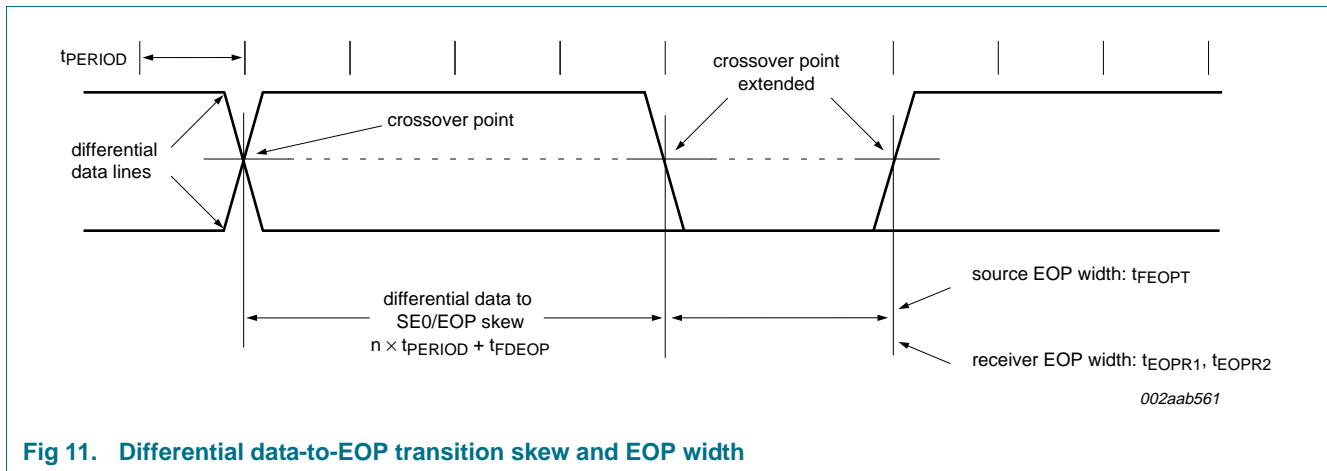

Fig 11. Differential data-to-EOP transition skew and EOP width

11.8 SPI

Table 14. Dynamic characteristics of SPI pins

$T_{amb} = -40\text{ }^{\circ}\text{C}$ to $+85\text{ }^{\circ}\text{C}$.

Symbol	Parameter	Min	Typ	Max	Unit
$T_{cy(PCLK)}$	PCLK cycle time	10	-	-	ns
T_{SPICYC}	SPI cycle time	[1] 79.6	-	-	ns
$t_{SPICLKH}$	SPICLK HIGH time	$0.485 \times T_{SPICYC}$	-	-	ns
$t_{SPICLKL}$	SPICLK LOW time	-	-	$0.515 \times T_{SPICYC}$	ns
SPI master					
t_{SPIDSU}	SPI data set-up time	[2] 0	-	-	ns
t_{SPIDH}	SPI data hold time	[2] $2 \times T_{cy(PCLK)} - 5$	-	-	ns
t_{SPIQV}	SPI data output valid time	[2] $2 \times T_{cy(PCLK)} + 30$	-	-	ns
t_{SPIOH}	SPI output data hold time	[2] $2 \times T_{cy(PCLK)} + 5$	-	-	ns
SPI slave					
t_{SPIDSU}	SPI data set-up time	[2] 0	-	-	ns
t_{SPIDH}	SPI data hold time	[2] $2 \times T_{cy(PCLK)} + 5$	-	-	ns
t_{SPIQV}	SPI data output valid time	[2] $2 \times T_{cy(PCLK)} + 35$	-	-	ns
t_{SPIOH}	SPI output data hold time	[2] $2 \times T_{cy(PCLK)} + 15$	-	-	ns

[1] $T_{SPICYC} = (T_{cy(PCLK)} \times n) \pm 0.5\%$, n is the SPI clock divider value ($n \geq 8$); PCLK is derived from the processor clock CCLK.

[2] Timing parameters are measured with respect to the 50 % edge of the clock SCK and the 10 % (90 %) edge of the data signal (MOSI or MISO).

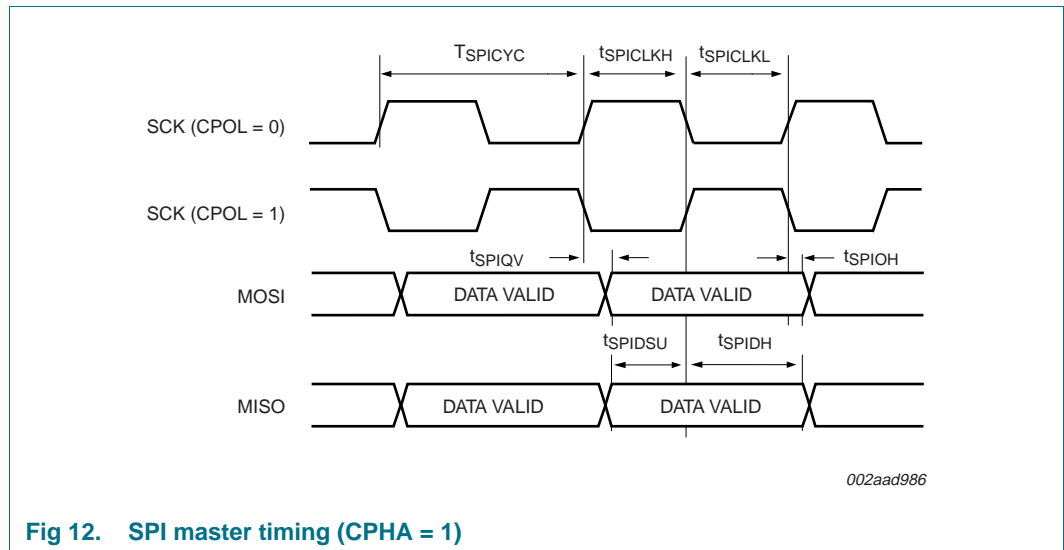

Fig 12. SPI master timing (CPHA = 1)

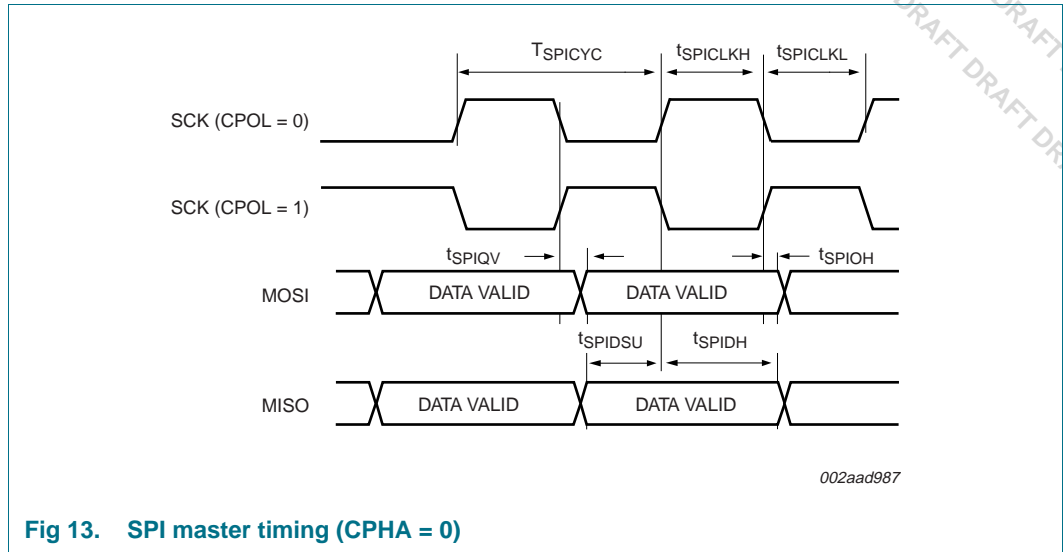

Fig 13. SPI master timing (CPHA = 0)

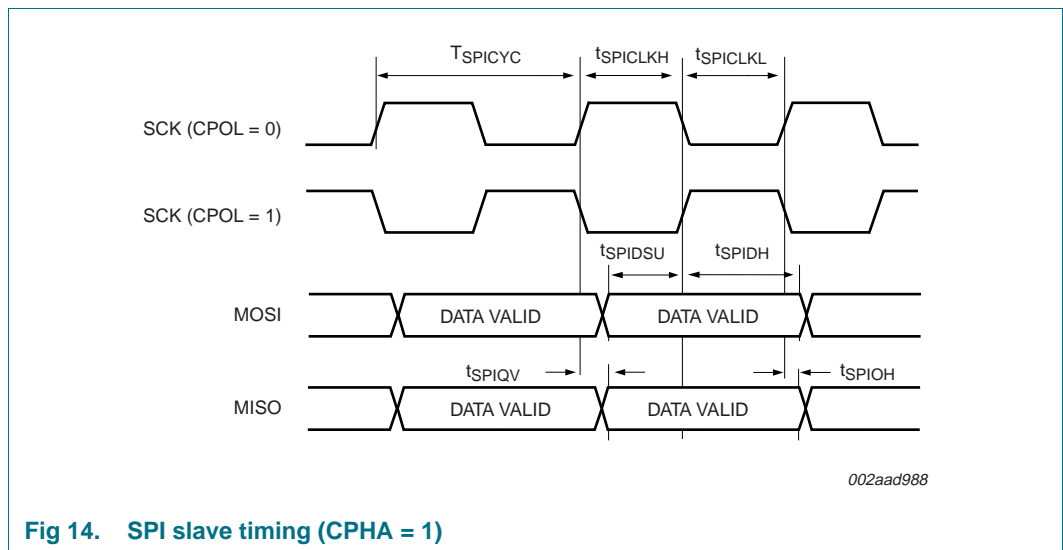

Fig 14. SPI slave timing (CPHA = 1)

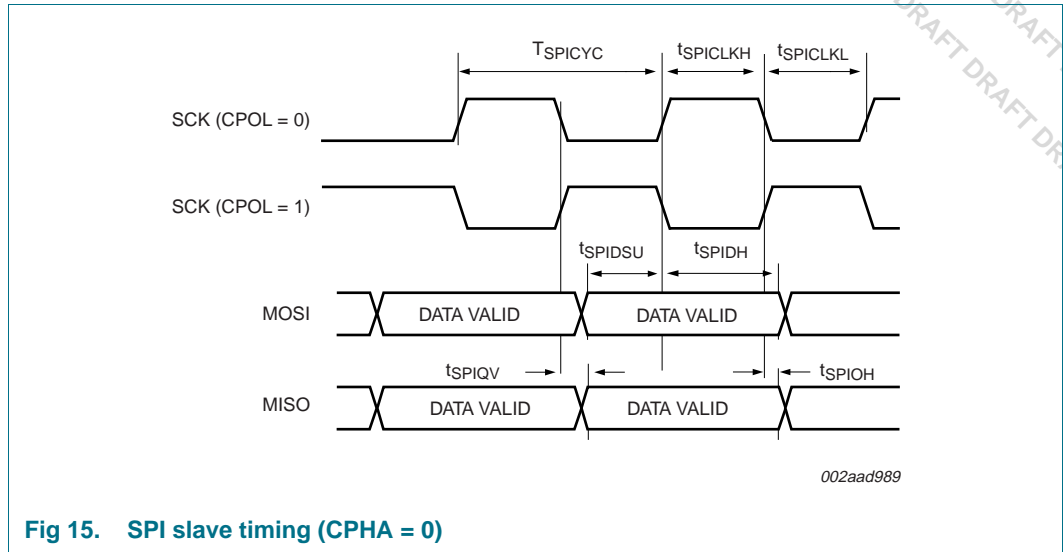

Fig 15. SPI slave timing (CPHA = 0)

12. ADC electrical characteristics

Table 15. ADC characteristics

$V_{DDA} = 2.7\text{ V to }3.6\text{ V}$; $T_{amb} = -40\text{ }^{\circ}\text{C to }+85\text{ }^{\circ}\text{C}$ unless otherwise specified; ADC frequency 13 MHz.

Symbol	Parameter	Conditions	Min	Typ	Max	Unit
V_{IA}	analog input voltage		0	-	V_{DDA}	V
C_{ia}	analog input capacitance		-	-	15	pF
E_D	differential linearity error		[1][2][3]	-	± 1	LSB
$E_{L(adj)}$	integral non-linearity		[1][4]	-	± 3	LSB
E_O	offset error		[1][5]	± 2	-	LSB
E_G	gain error		[1][6]	-	0.5	%
E_T	absolute error		[1][7]	-	4	LSB
$f_{clk(ADC)}$	ADC clock frequency		-	-	13	MHz
$f_c(ADC)$	ADC conversion frequency		-	-	200	kHz

- [1] Conditions: $V_{SSA} = 0\text{ V}$, $V_{DDA} = 3.3\text{ V}$.
- [2] The ADC is monotonic, there are no missing codes.
- [3] The differential linearity error (E_D) is the difference between the actual step width and the ideal step width. See [Figure 16](#).
- [4] The integral non-linearity ($E_{L(adj)}$) is the peak difference between the center of the steps of the actual and the ideal transfer curve after appropriate adjustment of gain and offset errors. See [Figure 16](#).
- [5] The offset error (E_O) is the absolute difference between the straight line which fits the actual curve and the straight line which fits the ideal curve. See [Figure 16](#).
- [6] The gain error (E_G) is the relative difference in percent between the straight line fitting the actual transfer curve after removing offset error, and the straight line which fits the ideal transfer curve. See [Figure 16](#).
- [7] The absolute error (E_T) is the maximum difference between the center of the steps of the actual transfer curve of the non-calibrated ADC and the ideal transfer curve. See [Figure 16](#).

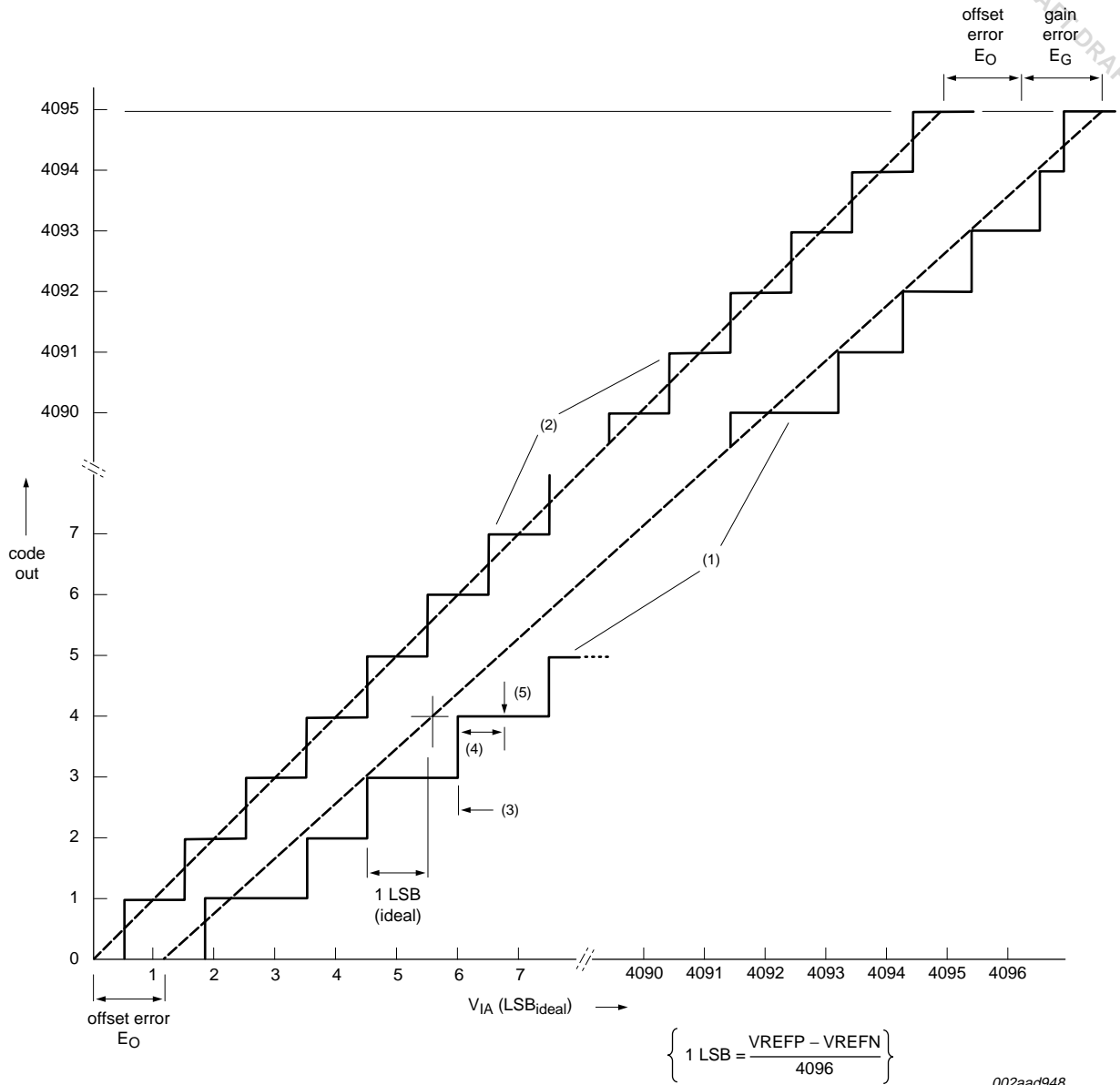

- (1) Example of an actual transfer curve.
- (2) The ideal transfer curve.
- (3) Differential linearity error (E_D).
- (4) Integral non-linearity ($E_{L(adj)}$).
- (5) Center of a step of the actual transfer curve.

Fig 16. 12-bit ADC characteristics

13. DAC electrical characteristics (LPC1768/66/65 only)

Table 16. DAC electrical characteristics

$V_{DDA} = 2.7\text{ V to }3.6\text{ V}$; $T_{amb} = -40\text{ }^{\circ}\text{C to }+85\text{ }^{\circ}\text{C}$ unless otherwise specified

Symbol	Parameter	Conditions	Min	Typ	Max	Unit
E_D	differential linearity error		-	-	± 1	LSB
$E_{L(\text{adj})}$	integral non-linearity		-	-	± 1.5	LSB
E_O	offset error		-	-	0.6	%
E_G	gain error		-	-	0.6	%
E_T	absolute error		-	-	<td>	LSB
C_L	load capacitance		-	-	200	pF
R_L	load resistance		1	-	-	k Ω

14. Application information

14.1 Suggested USB interface solutions

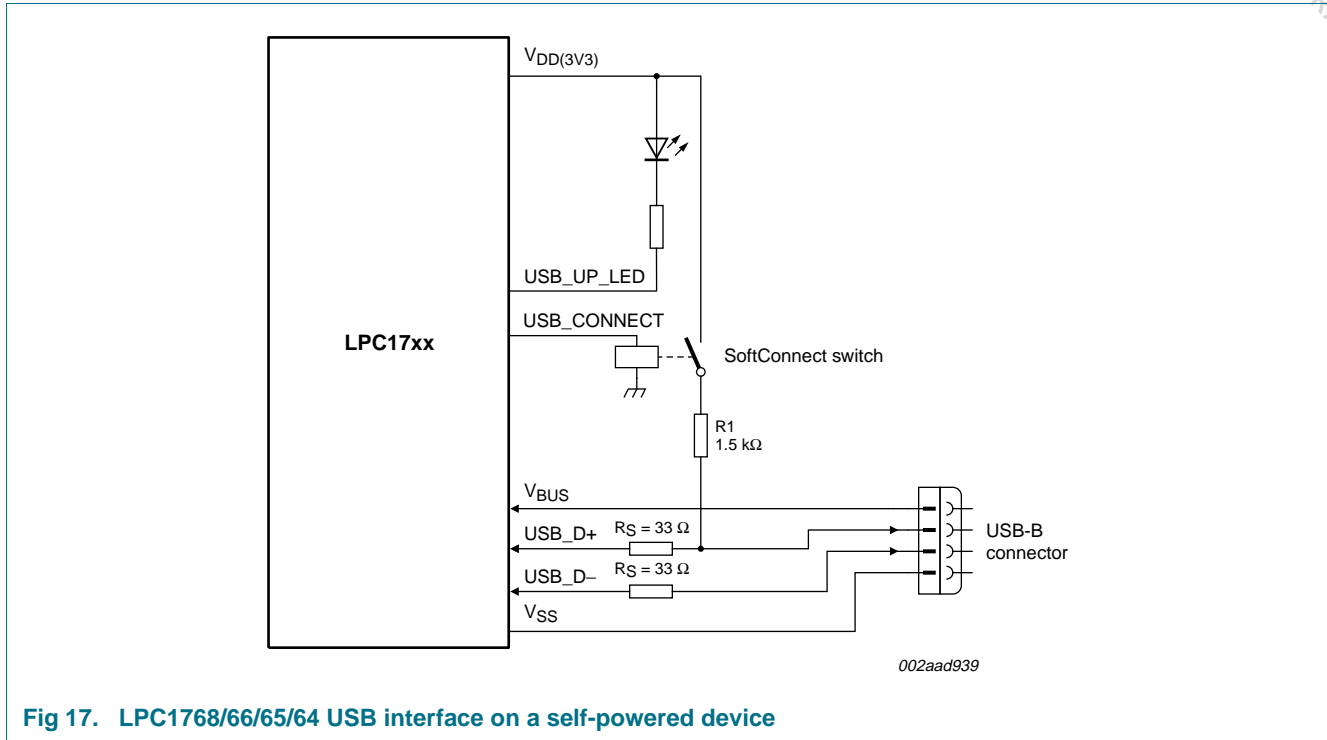

Fig 17. LPC1768/66/65/64 USB interface on a self-powered device

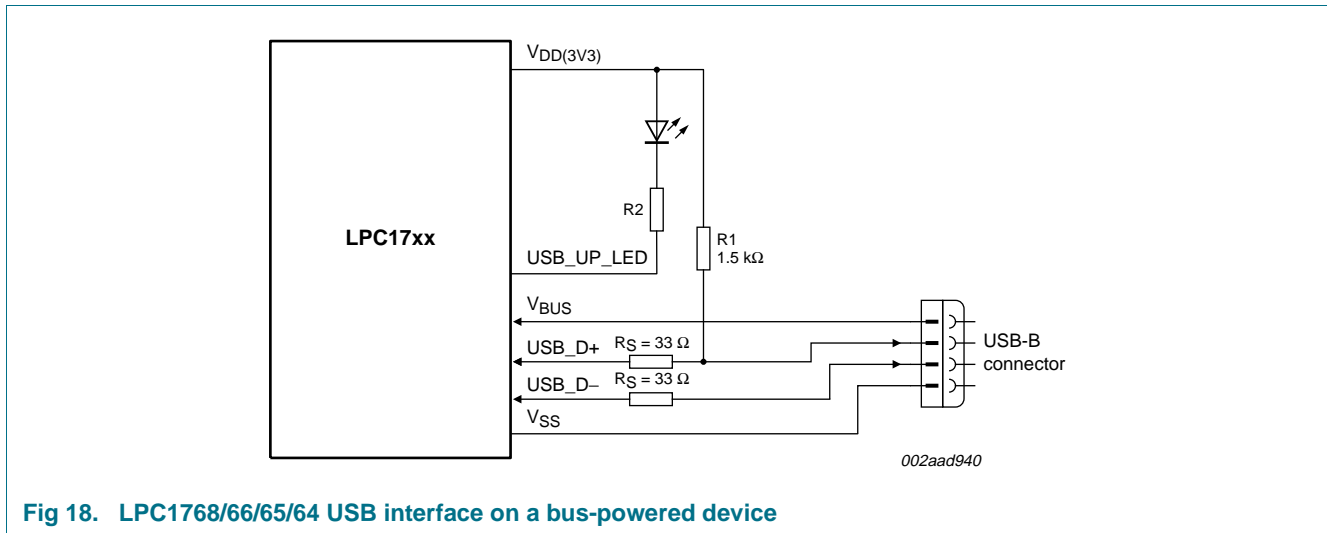

Fig 18. LPC1768/66/65/64 USB interface on a bus-powered device

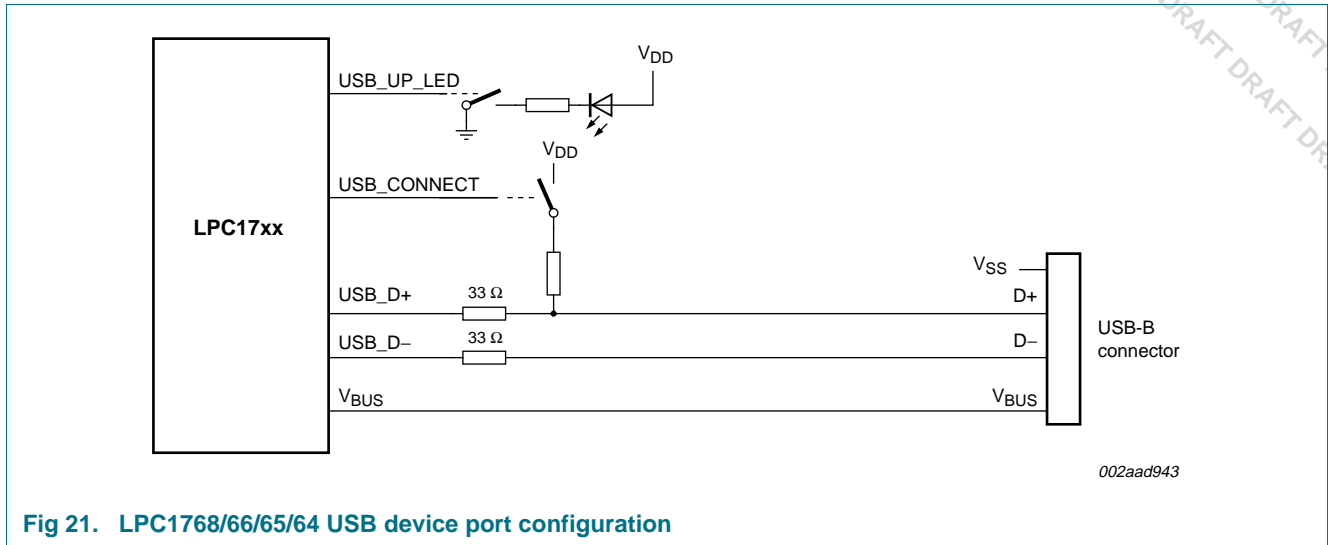

Fig 21. LPC1768/66/65/64 USB device port configuration

14.2 XTAL1 input

The input voltage to the on-chip oscillators is limited to 1.8 V. If the oscillator is driven by a clock in slave mode, it is recommended that the input be coupled through a capacitor with $C_i = 100$ pF. To limit the input voltage to the specified range, choose an additional capacitor to ground C_g which attenuates the input voltage by a factor $C_i / (C_i + C_g)$. In slave mode, a minimum of 200 mV(RMS) is needed. For more details see the *LPC17xx User manual*.

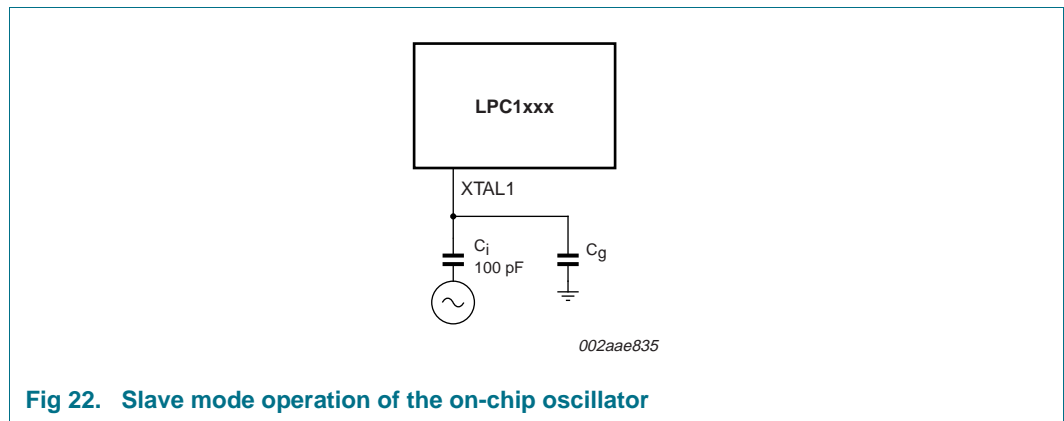

Fig 22. Slave mode operation of the on-chip oscillator

14.3 XTAL and RTCX Printed Circuit Board (PCB) layout guidelines

The crystal should be connected on the PCB as close as possible to the oscillator input and output pins of the chip. Take care that the load capacitors C_{x1} , C_{x2} , and C_{x3} in case of third overtone crystal usage have a common ground plane. The external components must also be connected to the ground plain. Loops must be made as small as possible in order to keep the noise coupled in via the PCB as small as possible. Also parasitics should stay as small as possible. Values of C_{x1} and C_{x2} should be chosen smaller accordingly to the increase in parasitics of the PCB layout.

15. Package outline

LQFP100: plastic low profile quad flat package; 100 leads; body 14 x 14 x 1.4 mm

SOT407-1

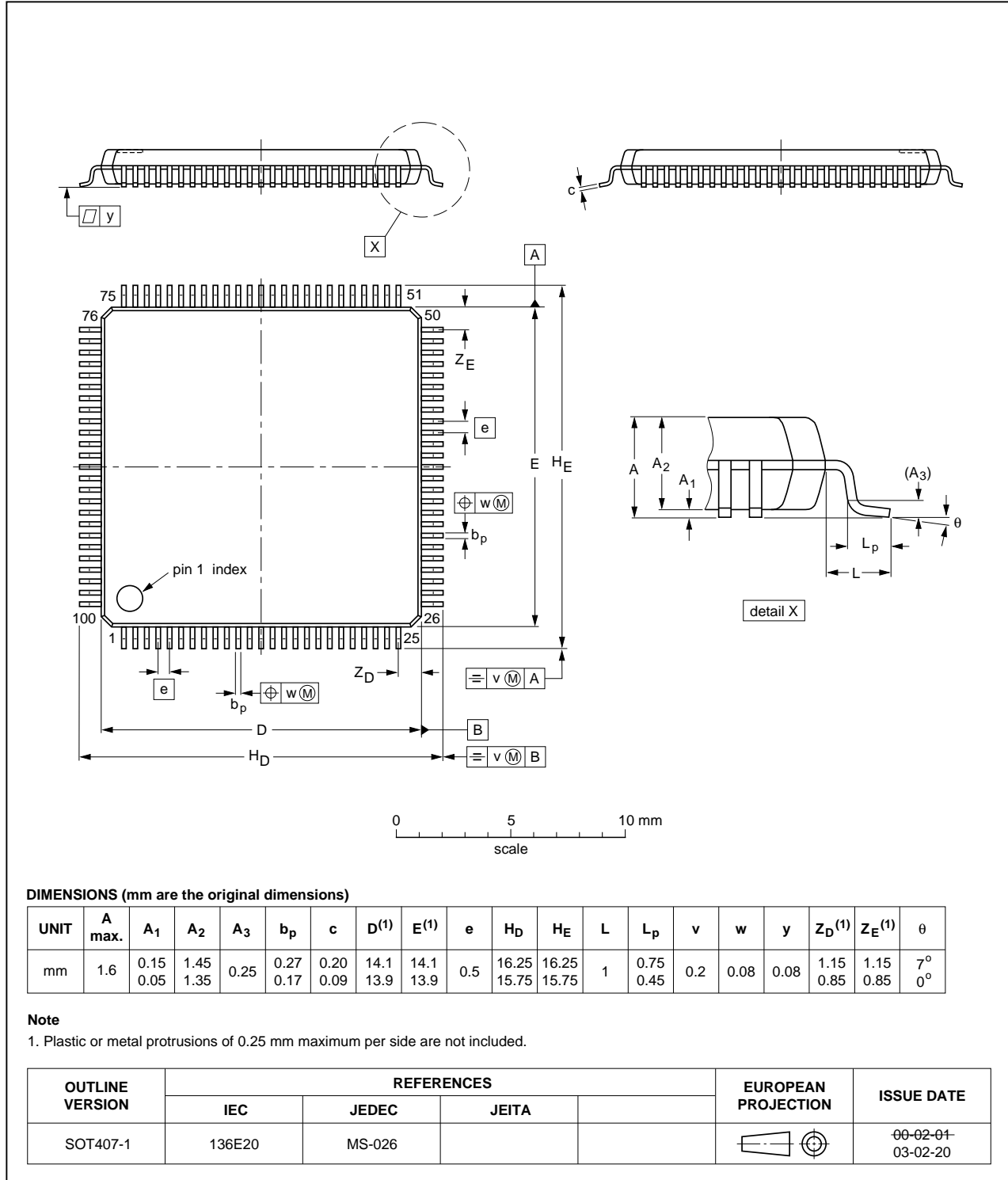

Fig 23. Package outline SOT407-1 (LQFP100)

16. Abbreviations

Table 17. Abbreviations

Acronym	Description
ADC	Analog-to-Digital Converter
AHB	Advanced High-performance Bus
AMBA	Advanced Microcontroller Bus Architecture
APB	Advanced Peripheral Bus
BOD	BrownOut Detection
CAN	Controller Area Network
DAC	Digital-to-Analog Converter
DCC	Debug Communication Channel
DMA	Direct Memory Access
DSP	Digital Signal Processing
EOP	End Of Packet
ETM	Embedded Trace Macrocell
GPIO	General Purpose Input/Output
IRC	Internal RC
IrDA	Infrared Data Association
JTAG	Joint Test Action Group
MAC	Media Access Control
MIIM	Media Independent Interface Management
OHCI	Open Host Controller Interface
OTG	On-The-Go
PHY	Physical Layer
PLL	Phase-Locked Loop
PWM	Pulse Width Modulator
RIT	Repetitive Interrupt Timer
RMII	Reduced Media Independent Interface
SE0	Single Ended Zero
SPI	Serial Peripheral Interface
SSI	Serial Synchronous Interface
SSP	Synchronous Serial Port
TCM	Tightly Coupled Memory
TTL	Transistor-Transistor Logic
UART	Universal Asynchronous Receiver/Transmitter
USB	Universal Serial Bus

17. Revision history

Table 18. Revision history

Document ID	Release date	Data sheet status	Change notice	Supersedes
LPC1768_66_65_64_2.06	<td>	Preliminary data sheet	-	LPC1768_66_65_64_2.05
Modifications:		<ul style="list-style-type: none"> • ADC absolute error E_T added (Table 15). • I²C-bus timing characteristics updated (Table 10). • ENET_MDC and ENET_MDIO functions removed from pin P2[8] and P2[9] (Table 3). • V_{esd} changed to ± 4000 V (Table 4). 		
LPC1768_66_65_64_2.05	<td>	Preliminary data sheet	-	LPC1768_66_65_64_2.04
Modifications:		<ul style="list-style-type: none"> • SPI timing characteristics added (Table 14). • I²C-bus timing characteristics added. • I²S-bus timing characteristics added (Table 11). • CLKOUT function removed from pin P1[25] (Table 3). 		
LPC1768_66_65_64_2.04	<td>	Preliminary data sheet	-	LPC1768_66_65_64_2.03
Modifications:		<ul style="list-style-type: none"> • Power consumption data added to Table 6. • ADC characteristics updated (Table 15). • DAC characteristics updated (Table 16). • V_{DDA} and VREFP pin descriptions updated (Table 3). • SPI timing characteristics added. • Data sheet status changed to Preliminary data sheet. 		
LPC1768_66_65_64_2.03	<td>	Objective data sheet	-	LPC1768_66_65_64_2.02
Modifications:		<ul style="list-style-type: none"> • Flash characteristics table updated (Table 7). • ADC conversion rate changed to 200 kHz. • XTAL1 circuit and PCB layout recommendations added (see Section 14.2 and Section 14.3). 		
LPC1768_66_65_64_2.02	<td>	Objective data sheet	-	LPC1768_66_65_64_2.01
Modifications:		<ul style="list-style-type: none"> • Flash characteristics table updated. • Maximum data bit rate for SPI, SSP, UART added. • RTC back-up RAM size updated (20 bytes). • WDT clock source added: RTC oscillator. 		
LPC1768_66_65_64_2.01	<td>	Objective data sheet	-	LPC1768_66_65_64_2
Modifications:		<ul style="list-style-type: none"> • Updated parameters E_D and $E_{L(adj)}$ in Table 15 "ADC characteristics". • Updated motor control PWM pin names in Table 3 "Pin description" and Figure 1 "Block diagram". • CLKOUT function added to pin P1[25] in Table 3 "Pin description". 		
LPC1768_66_65_64_2	<td>	Objective data sheet	-	LPC1768_66_65_64_1
Modifications:		<ul style="list-style-type: none"> • Updated Flash characteristics. • Updated Figure 3 "LPC1768/66/65/64 memory map". • Updated descriptive title. 		
LPC1768_66_65_64_1	20090115	Objective data sheet	-	-

18. Legal information

19. Data sheet status

Document status ^{[1][2]}	Product status ^[3]	Definition
Objective [short] data sheet	Development	This document contains data from the objective specification for product development.
Preliminary [short] data sheet	Qualification	This document contains data from the preliminary specification.
Product [short] data sheet	Production	This document contains the product specification.

[1] Please consult the most recently issued document before initiating or completing a design.

[2] The term 'short data sheet' is explained in section "Definitions".

[3] The product status of device(s) described in this document may have changed since this document was published and may differ in case of multiple devices. The latest product status information is available on the Internet at URL <http://www.nxp.com>.

19.1 Definitions

Draft — The document is a draft version only. The content is still under internal review and subject to formal approval, which may result in modifications or additions. NXP Semiconductors does not give any representations or warranties as to the accuracy or completeness of information included herein and shall have no liability for the consequences of use of such information.

Short data sheet — A short data sheet is an extract from a full data sheet with the same product type number(s) and title. A short data sheet is intended for quick reference only and should not be relied upon to contain detailed and full information. For detailed and full information see the relevant full data sheet, which is available on request via the local NXP Semiconductors sales office. In case of any inconsistency or conflict with the short data sheet, the full data sheet shall prevail.

19.2 Disclaimers

General — Information in this document is believed to be accurate and reliable. However, NXP Semiconductors does not give any representations or warranties, expressed or implied, as to the accuracy or completeness of such information and shall have no liability for the consequences of use of such information.

Right to make changes — NXP Semiconductors reserves the right to make changes to information published in this document, including without limitation specifications and product descriptions, at any time and without notice. This document supersedes and replaces all information supplied prior to the publication hereof.

Suitability for use — NXP Semiconductors products are not designed, authorized or warranted to be suitable for use in medical, military, aircraft, space or life support equipment, nor in applications where failure or malfunction of an NXP Semiconductors product can reasonably be expected to result in personal injury, death or severe property or environmental

damage. NXP Semiconductors accepts no liability for inclusion and/or use of NXP Semiconductors products in such equipment or applications and therefore such inclusion and/or use is at the customer's own risk.

Applications — Applications that are described herein for any of these products are for illustrative purposes only. NXP Semiconductors makes no representation or warranty that such applications will be suitable for the specified use without further testing or modification.

Limiting values — Stress above one or more limiting values (as defined in the Absolute Maximum Ratings System of IEC 60134) may cause permanent damage to the device. Limiting values are stress ratings only and operation of the device at these or any other conditions above those given in the Characteristics sections of this document is not implied. Exposure to limiting values for extended periods may affect device reliability.

Terms and conditions of sale — NXP Semiconductors products are sold subject to the general terms and conditions of commercial sale, as published at <http://www.nxp.com/profile/terms>, including those pertaining to warranty, intellectual property rights infringement and limitation of liability, unless explicitly otherwise agreed to in writing by NXP Semiconductors. In case of any inconsistency or conflict between information in this document and such terms and conditions, the latter will prevail.

No offer to sell or license — Nothing in this document may be interpreted or construed as an offer to sell products that is open for acceptance or the grant, conveyance or implication of any license under any copyrights, patents or other industrial or intellectual property rights.

Export control — This document as well as the item(s) described herein may be subject to export control regulations. Export might require a prior authorization from national authorities.

19.3 Trademarks

Notice: All referenced brands, product names, service names and trademarks are the property of their respective owners.

I²C-bus — logo is a trademark of NXP B.V.

20. Contact information

For more information, please visit: <http://www.nxp.com>

For sales office addresses, please send an email to: salesaddresses@nxp.com

21. Contents

1	General description	1	7.23	Motor control PWM	28
2	Features	1	7.24	Quadrature Encoder Interface (QEI)	28
3	Applications	3	7.24.1	Features	28
4	Ordering information	4	7.25	Repetitive Interrupt (RI) timer	29
4.1	Ordering options	4	7.25.1	Features	29
5	Block diagram	5	7.26	ARM Cortex-M3 system tick timer	29
6	Pinning information	6	7.27	Watchdog timer	29
6.1	Pinning	6	7.27.1	Features	29
6.2	Pin description	6	7.28	RTC and backup registers	30
7	Functional description	15	7.28.1	Features	30
7.1	Architectural overview	15	7.29	Clocking and power control	30
7.2	ARM Cortex-M3 processor	15	7.29.1	Crystal oscillators	30
7.3	On-chip flash program memory	15	7.29.1.1	Internal RC oscillator	31
7.4	On-chip SRAM	15	7.29.1.2	Main oscillator	31
7.5	Memory Protection Unit (MPU)	15	7.29.1.3	RTC oscillator	31
7.6	Memory map	16	7.29.2	Main PLL (PLL0)	32
7.7	Nested Vectored Interrupt Controller (NVIC)	18	7.29.3	USB PLL (PLL1)	32
7.7.1	Features	18	7.29.4	RTC clock output	32
7.7.2	Interrupt sources	18	7.29.5	Wake-up timer	32
7.8	Pin connect block	18	7.29.6	Power control	33
7.9	General purpose DMA controller	18	7.29.6.1	Sleep mode	33
7.9.1	Features	19	7.29.6.2	Deep-sleep mode	33
7.10	Fast general purpose parallel I/O	19	7.29.6.3	Power-down mode	34
7.10.1	Features	20	7.29.6.4	Deep power-down mode	34
7.11	Ethernet (LPC1768/66/64 only)	20	7.29.6.5	Wakeup interrupt controller	34
7.11.1	Features	20	7.29.7	Peripheral power control	34
7.12	USB interface	21	7.29.8	Power domains	35
7.12.1	USB device controller	21	7.30	System control	36
7.12.1.1	Features	21	7.30.1	Reset	36
7.12.2	USB host controller (LPC1768/66/65 only)	22	7.30.2	Brownout detection	37
7.12.2.1	Features	22	7.30.3	Code security (Code Read Protection - CRP)	37
7.12.3	USB OTG controller (LPC1768/66/65 only)	22	7.30.4	APB interface	37
7.12.3.1	Features	22	7.30.5	AHB multilayer matrix	38
7.13	CAN controller and acceptance filters	22	7.30.6	External interrupt inputs	38
7.13.1	Features	23	7.30.7	Memory mapping control	38
7.14	12-bit ADC	23	7.31	Emulation and debugging	38
7.14.1	Features	23	8	Limiting values	39
7.15	10-bit DAC (LPC1768/66/65 only)	23	9	Thermal characteristics	40
7.15.1	Features	23	9.1	Thermal characteristics	40
7.16	UARTs	24	10	Static characteristics	41
7.16.1	Features	24	11	Dynamic characteristics	44
7.17	SPI serial I/O controller	24	11.1	Flash memory	44
7.17.1	Features	24	11.2	External clock	44
7.18	SSP serial I/O controller	24	11.3	Internal oscillators	45
7.18.1	Features	25	11.4	I ² C-bus	45
7.19	I ² C-bus serial I/O controllers	25	11.5	I ² S-bus interface	46
7.19.1	Features	25	11.6	SSP interface	48
7.20	I ² S-bus serial I/O controllers	25	11.7	USB interface	49
7.20.1	Features	26	11.8	SPI	50
7.21	General purpose 32-bit timers/external event counters	26	12	ADC electrical characteristics	52
7.21.1	Features	26	13	DAC electrical characteristics (LPC1768/66/65 only)	54
7.22	Pulse width modulator	27	14	Application information	55
7.22.1	Features	27	14.1	Suggested USB interface solutions	55

