

FEATURES

High Dynamic Range

Output IP3: +22 dBm: Re 50 Ω @ 250 MHz

Low Noise Figure: 5.9 dB @ 250 MHz

Two Gain Versions:

AD8350-15 15 dB

AD8350-20 20 dB

-3 dB Bandwidth: 1.0 GHz

Single Supply Operation: +5 V to +10 V

Supply Current: 28 mA

Input/Output Impedance: 200 Ω

Single-Ended or Differential Input Drive

8-Lead SOIC Package

APPLICATIONS

Cellular Base Stations

Communications Receivers

RF/IF Gain Block

Differential A-to-D Driver

SAW Filter Interface

Single-Ended to Differential Conversion

High Performance Video

High Speed Data Transmission

PRODUCT DESCRIPTION

The AD8350 series are high performance fully-differential amplifiers useful in RF and IF circuits up to 1000 MHz. The amplifier has excellent noise figure of 5.9 dB at 250 MHz. It offers a high output third order intercept (OIP3) of +22 dBm at 250 MHz. Gain versions of 15 dB and 20 dB are offered.

The AD8350 is designed to meet the demanding performance requirements of communications transceiver applications. It enables a high dynamic range differential signal chain, with exceptional linearity and increased common-mode rejection. The device can be used as a general purpose gain block, an A-to-D driver, and high speed data interface driver, among other functions. The AD8350 input can also be used as a single-ended-to-differential converter.

FUNCTIONAL BLOCK DIAGRAMS

8-Lead SOIC Package (with Enable)

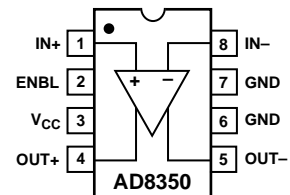

The amplifier can be operated down to +5 V with an OIP3 of +22 dBm at 250 MHz and slightly reduced distortion performance. The wide bandwidth, high dynamic range and temperature stability make this product ideal for the various RF and IF frequencies required in cellular, CATV, broadband, instrumentation and other applications.

The AD8350 is offered in an 8-lead single SOIC package. It operates from +5 V and +10 V power supplies, drawing 28 mA typical. The AD8350 offers a power enable function for power-sensitive applications. The AD8350 is fabricated using Analog Devices' proprietary high speed complementary bipolar process. The device is available in the industrial (-40°C to +85°C) temperature range.

REV. 0

Information furnished by Analog Devices is believed to be accurate and reliable. However, no responsibility is assumed by Analog Devices for its use, nor for any infringements of patents or other rights of third parties which may result from its use. No license is granted by implication or otherwise under any patent or patent rights of Analog Devices.

AD8350-15-SPECIFICATIONS (@ +25°C, $V_S = +5\text{ V}$, $G = 15\text{ dB}$, unless otherwise noted. All specifications refer to differential inputs and differential outputs unless noted.)

Parameter	Conditions	Min	Typ	Max	Units
DYNAMIC PERFORMANCE					
-3 dB Bandwidth	$V_S = +5\text{ V}$, $V_{OUT} = 1\text{ V p-p}$		0.9		GHz
	$V_S = +10\text{ V}$, $V_{OUT} = 1\text{ V p-p}$		1.1		GHz
Bandwidth for 0.1 dB Flatness	$V_S = +5\text{ V}$, $V_{OUT} = 1\text{ V p-p}$		270		MHz
	$V_S = +10\text{ V}$, $V_{OUT} = 1\text{ V p-p}$		270		MHz
Slew Rate	$V_{OUT} = 1\text{ V p-p}$		2000		V/ μs
Settling Time	0.1%, $V_{OUT} = 1\text{ V p-p}$		10		ns
Gain (S21) ¹	$V_S = +5\text{ V}$, $f = 50\text{ MHz}$	14	15	16	dB
Gain Supply Sensitivity	$V_S = +5\text{ V to } +10\text{ V}$, $f = 50\text{ MHz}$		0.003		dB/V
Gain Temperature Sensitivity	T_{MIN} to T_{MAX}		-0.002		dB/ $^{\circ}\text{C}$
Isolation (S12) ¹	$f = 50\text{ MHz}$		-18		dB
NOISE/HARMONIC PERFORMANCE					
50 MHz Signal					
Second Harmonic	$V_S = +5\text{ V}$, $V_{OUT} = 1\text{ V p-p}$		-66		dBc
	$V_S = +10\text{ V}$, $V_{OUT} = 1\text{ V p-p}$		-67		dBc
Third Harmonic	$V_S = +5\text{ V}$, $V_{OUT} = 1\text{ V p-p}$		-65		dBc
	$V_S = +10\text{ V}$, $V_{OUT} = 1\text{ V p-p}$		-70		dBc
Output Second Order Intercept ²	$V_S = +5\text{ V}$		52		dBm
	$V_S = +10\text{ V}$		52		dBm
Output Third Order Intercept ²	$V_S = +5\text{ V}$		22		dBm
	$V_S = +10\text{ V}$		23		dBm
250 MHz Signal					
Second Harmonic	$V_S = +5\text{ V}$, $V_{OUT} = 1\text{ V p-p}$		-48		dBc
	$V_S = +10\text{ V}$, $V_{OUT} = 1\text{ V p-p}$		-49		dBc
Third Harmonic	$V_S = +5\text{ V}$, $V_{OUT} = 1\text{ V p-p}$		-52		dBc
	$V_S = +10\text{ V}$, $V_{OUT} = 1\text{ V p-p}$		-61		dBc
Output Second Order Intercept ²	$V_S = +5\text{ V}$		33		dBm
	$V_S = +10\text{ V}$		34		dBm
Output Third Order Intercept ²	$V_S = +5\text{ V}$		18		dBm
	$V_S = +10\text{ V}$		22		dBm
1 dB Compression Point (RTI) ²	$V_S = +5\text{ V}$		2		dBm
	$V_S = +10\text{ V}$		5		dBm
Voltage Noise (RTI)	$f = 150\text{ MHz}$		1.7		nV/ $\sqrt{\text{Hz}}$
Noise Figure	$f = 150\text{ MHz}$		6.8		dB
INPUT/OUTPUT CHARACTERISTICS					
Differential Offset Voltage (RTI)	$V_{OUT+} - V_{OUT-}$		± 1		mV
Differential Offset Drift	T_{MIN} to T_{MAX}		0.02		mV/ $^{\circ}\text{C}$
Input Bias Current			15		μA
Input Resistance	Real		200		Ω
Input Capacitance			2		pF
CMRR	$f = 50\text{ MHz}$		-67		dB
Output Resistance	Real		200		Ω
Output Capacitance			2		pF
POWER SUPPLY					
Operating Range		+4		+11.0	V
Quiescent Current	Powered Up, $V_S = +5\text{ V}$	25	28	32	mA
	Powered Down, $V_S = +5\text{ V}$	3	3.8	5.5	mA
	Powered Up, $V_S = +10\text{ V}$	27	30	34	mA
	Powered Down, $V_S = +10\text{ V}$	3	4	6.5	mA
Power-Up/Down Switching			15		ns
Power Supply Rejection Ratio	$f = 50\text{ MHz}$, $V_S \Delta = 1\text{ V p-p}$		-58		dB
OPERATING TEMPERATURE RANGE					
		-40		+85	$^{\circ}\text{C}$

NOTES

¹See Tables I-IV for complete list of S-Parameters.

²Re: 50 Ω .

Specifications subject to change without notice.

AD8350-20-SPECIFICATIONS

(@ +25°C, $V_S = +5\text{ V}$, $G = 20\text{ dB}$, unless otherwise noted. All specifications refer to differential inputs and differential outputs unless noted.)

AD8350

Parameter	Conditions	Min	Typ	Max	Units
DYNAMIC PERFORMANCE					
-3 dB Bandwidth	$V_S = +5\text{ V}$, $V_{OUT} = 1\text{ V p-p}$		0.7		GHz
	$V_S = +10\text{ V}$, $V_{OUT} = 1\text{ V p-p}$		0.9		GHz
Bandwidth for 0.1 dB Flatness	$V_S = +5\text{ V}$, $V_{OUT} = 1\text{ V p-p}$		230		MHz
	$V_S = +10\text{ V}$, $V_{OUT} = 1\text{ V p-p}$		200		MHz
Slew Rate	$V_{OUT} = 1\text{ V p-p}$		2000		V/ μs
Settling Time	0.1%, $V_{OUT} = 1\text{ V p-p}$		15		ns
Gain (S21) ¹	$V_S = +5\text{ V}$, $f = 50\text{ MHz}$	19	20	21	dB
Gain Supply Sensitivity	$V_S = +5\text{ V to } +10\text{ V}$, $f = 50\text{ MHz}$		0.003		dB/V
Gain Temperature Sensitivity	T_{MIN} to T_{MAX}		-0.002		dB/ $^{\circ}\text{C}$
Isolation (S12) ¹	$f = 50\text{ MHz}$		-22		dB
NOISE / HARMONIC PERFORMANCE					
50 MHz Signal					
Second Harmonic	$V_S = +5\text{ V}$, $V_{OUT} = 1\text{ V p-p}$		-65		dBc
	$V_S = +10\text{ V}$, $V_{OUT} = 1\text{ V p-p}$		-66		dBc
Third Harmonic	$V_S = +5\text{ V}$, $V_{OUT} = 1\text{ V p-p}$		-66		dBc
	$V_S = +10\text{ V}$, $V_{OUT} = 1\text{ V p-p}$		-70		dBc
Output Second Order Intercept ²	$V_S = +5\text{ V}$		50		dBm
	$V_S = +10\text{ V}$		50		dBm
Output Third Order Intercept ²	$V_S = +5\text{ V}$		22		dBm
	$V_S = +10\text{ V}$		23		dBm
250 MHz Signal					
Second Harmonic	$V_S = +5\text{ V}$, $V_{OUT} = 1\text{ V p-p}$		-45		dBc
	$V_S = +10\text{ V}$, $V_{OUT} = 1\text{ V p-p}$		-46		dBc
Third Harmonic	$V_S = +5\text{ V}$, $V_{OUT} = 1\text{ V p-p}$		-55		dBc
	$V_S = +10\text{ V}$, $V_{OUT} = 1\text{ V p-p}$		-60		dBc
Output Second Order Intercept ²	$V_S = +5\text{ V}$		31		dBm
	$V_S = +10\text{ V}$		32		dBm
Output Third Order Intercept ²	$V_S = +5\text{ V}$		18		dBm
	$V_S = +10\text{ V}$		22		dBm
1 dB Compression Point (RTI) ²	$V_S = +5\text{ V}$		-2.6		dBm
	$V_S = +10\text{ V}$		1.8		dBm
Voltage Noise (RTI)	$f = 150\text{ MHz}$		1.7		nV/ $\sqrt{\text{Hz}}$
Noise Figure	$f = 150\text{ MHz}$		5.6		dB
INPUT/OUTPUT CHARACTERISTICS					
Differential Offset Voltage (RTI)	$V_{OUT+} - V_{OUT-}$		± 1		mV
Differential Offset Drift	T_{MIN} to T_{MAX}		0.02		mV/ $^{\circ}\text{C}$
Input Bias Current			15		μA
Input Resistance	Real		200		Ω
Input Capacitance			2		pF
CMRR	$f = 50\text{ MHz}$		-52		dB
Output Resistance	Real		200		Ω
Output Capacitance			2		pF
POWER SUPPLY					
Operating Range		+4		+11.0	V
Quiescent Current	Powered Up, $V_S = +5\text{ V}$	25	28	32	mA
	Powered Down, $V_S = +5\text{ V}$	3	3.8	5.5	mA
	Powered Up, $V_S = +10\text{ V}$	27	30	34	mA
	Powered Down, $V_S = +10\text{ V}$	3	4	6.5	mA
Power-Up/Down Switching			15		ns
Power Supply Rejection Ratio	$f = 50\text{ MHz}$, $V_S \Delta = 1\text{ V p-p}$		-45		dB
OPERATING TEMPERATURE RANGE					
		-40		+85	$^{\circ}\text{C}$

NOTES

¹See Tables I-IV for complete list of S-Parameters.

²Re: 50 Ω .

Specifications subject to change without notice.

AD8350

ABSOLUTE MAXIMUM RATINGS*

Supply Voltage, V_S	+11 V
Input Power Differential	+8 dBm
Internal Power Dissipation	400 mW
θ_{JA}	100°C/W
Maximum Junction Temperature	+125°C
Operating Temperature Range	-40°C to +85°C
Storage Temperature Range	-65°C to +150°C
Lead Temperature Range (Soldering 60 sec)	+300°C

*Stresses above those listed under Absolute Maximum Ratings may cause permanent damage to the device. This is a stress rating only; functional operation of the device at these or any other conditions above those indicated in the operational section of this specification is not implied. Exposure to absolute maximum rating conditions for extended periods may effect device reliability.

PIN CONFIGURATION

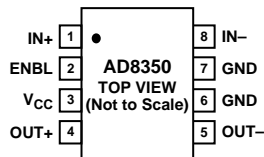

PIN FUNCTION DESCRIPTIONS

Pin	Function	Description
1, 8	IN+, IN-	Differential Inputs. IN+ and IN- should be ac-coupled (pins have a dc bias of midsupply). Differential input impedance is 200 Ω .
2	ENBL	Power-up Pin. A high level (5 V) enables the device; a low level (0 V) puts device in sleep mode.
3	V_{CC}	Positive Supply Voltage. +5 V to +10 V.
4, 5	OUT+, OUT-	Differential Outputs. OUT+ and OUT- should be ac-coupled (pins have a dc bias of midsupply). Differential input impedance is 200 Ω .
6, 7	GND	Common External Ground Reference.

ORDERING GUIDE

Model	Temperature Range	Package Description	Package Option
AD8350AR15	-40°C to +85°C	8-Lead SOIC	SO-8
AD8350AR15-REEL ¹	-40°C to +85°C	8-Lead SOIC	SO-8
AD8350AR15-REEL ⁷²	-40°C to +85°C	8-Lead SOIC	SO-8
AD8350AR15-EVAL		Evaluation Board (15 dB)	
AD8350AR20	-40°C to +85°C	8-Lead SOIC	SO-8
AD8350AR20-REEL ¹	-40°C to +85°C	8-Lead SOIC	SO-8
AD8350AR20-REEL ⁷²	-40°C to +85°C	8-Lead SOIC	SO-8
AD8350AR20-EVAL		Evaluation Board (20 dB)	

NOTES

¹13" Reels of 2500 each.

⁷²7" Reels of 750 each.

CAUTION

ESD (electrostatic discharge) sensitive device. Electrostatic charges as high as 4000 V readily accumulate on the human body and test equipment and can discharge without detection. Although the AD8350 features proprietary ESD protection circuitry, permanent damage may occur on devices subjected to high energy electrostatic discharges. Therefore, proper ESD precautions are recommended to avoid performance degradation or loss of functionality.



Typical Performance Characteristics—AD8350

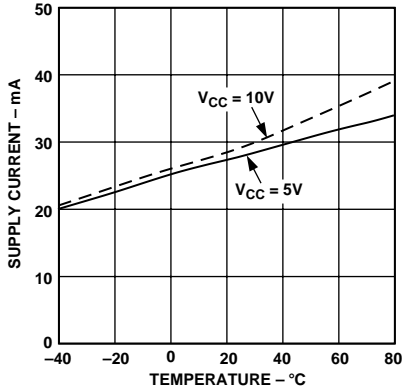

Figure 1. Supply Current vs. Temperature

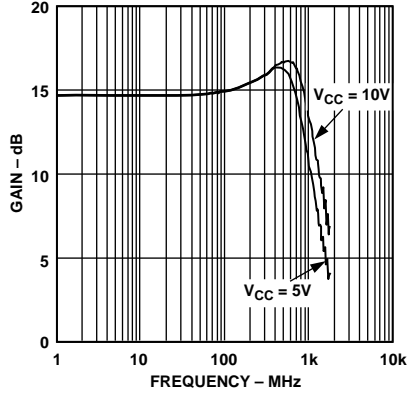

Figure 2. AD8350-15 Gain (S21) vs. Frequency

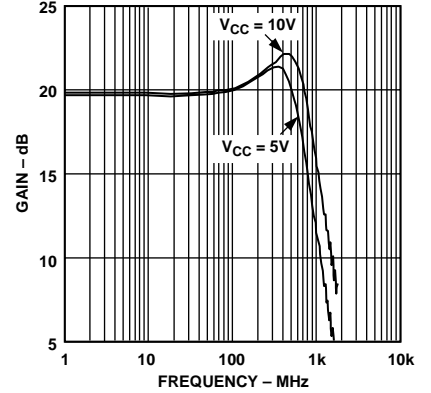

Figure 3. AD8350-20 Gain (S21) vs. Frequency

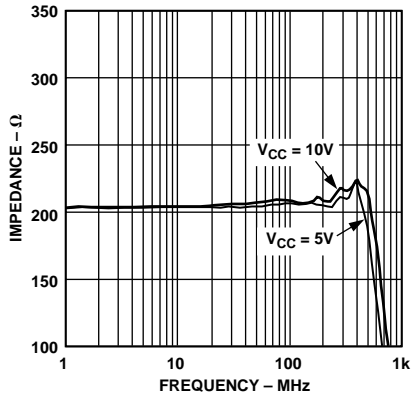

Figure 4. AD8350-15 Input Impedance vs. Frequency

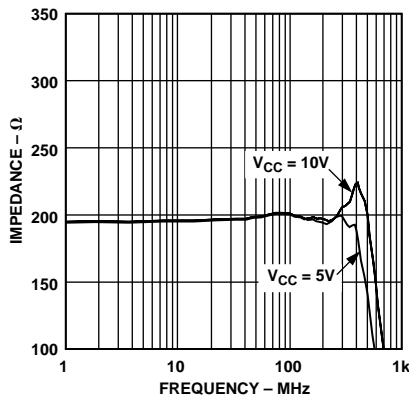

Figure 5. AD8350-20 Input Impedance vs. Frequency

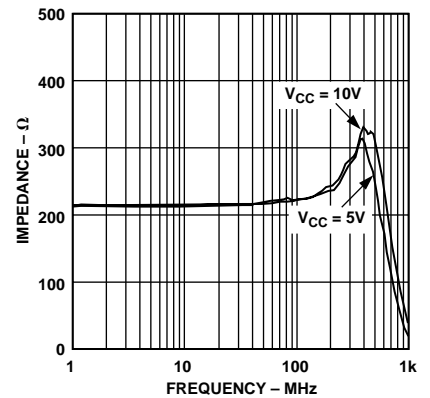

Figure 6. AD8350-15 Output Impedance vs. Frequency

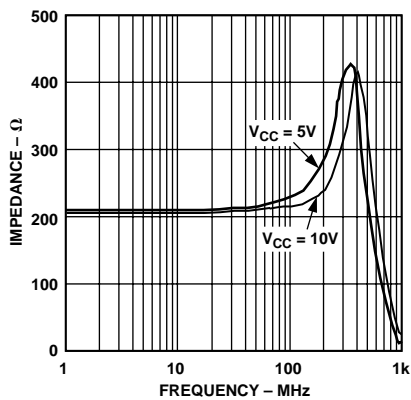

Figure 7. AD8350-20 Output Impedance vs. Frequency

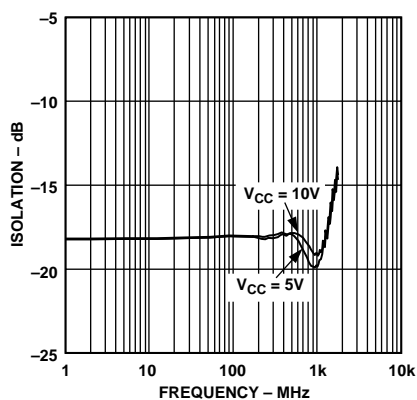

Figure 8. AD8350-15 Isolation (S12) vs. Frequency

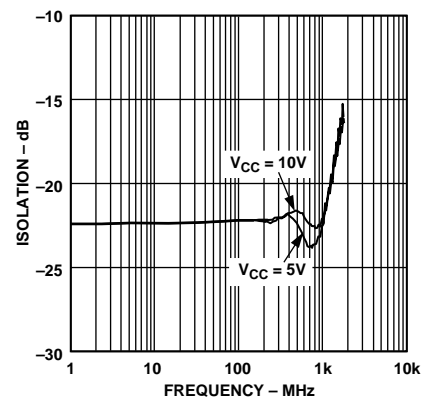

Figure 9. AD8350-20 Isolation (S12) vs. Frequency

AD8350

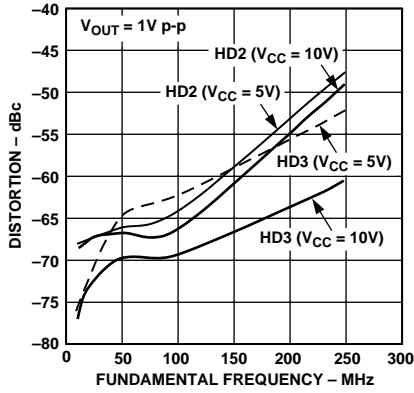

Figure 10. AD8350-15 Harmonic Distortion vs. Frequency

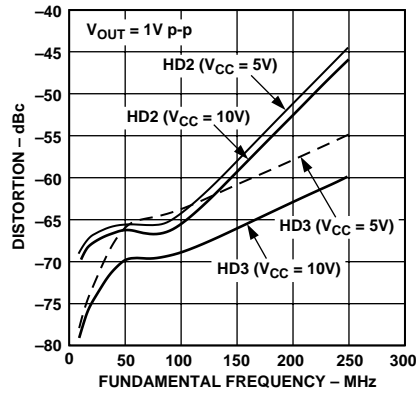

Figure 11. AD8350-20 Harmonic Distortion vs. Frequency

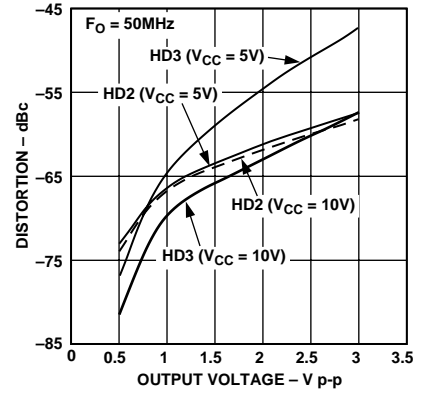

Figure 12. AD8350-15 Harmonic Distortion vs. Differential Output Voltage

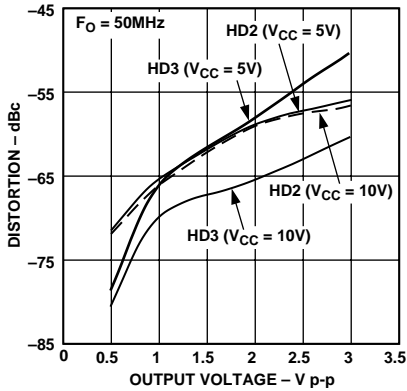

Figure 13. AD8350-20 Harmonic Distortion vs. Differential Output Voltage

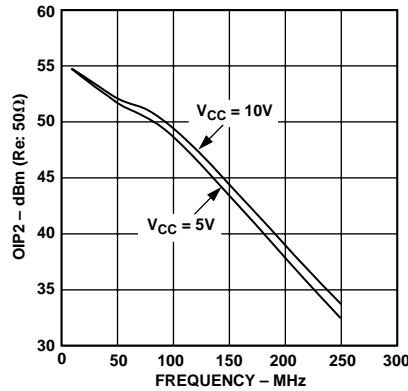

Figure 14. AD8350-15 Output Referred IP2 vs. Frequency

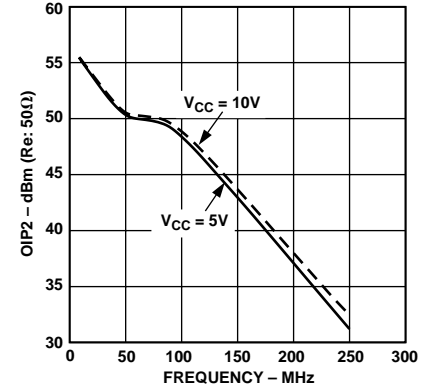

Figure 15. AD8350-20 Output Referred IP2 vs. Frequency

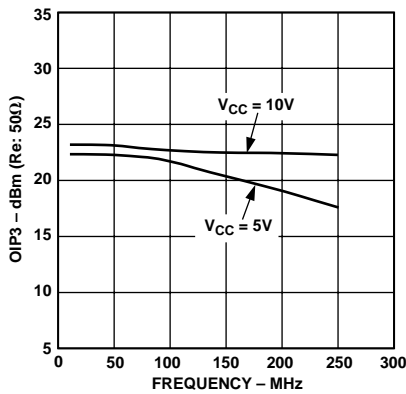

Figure 16. AD8350-15 Output Referred IP3 vs. Frequency

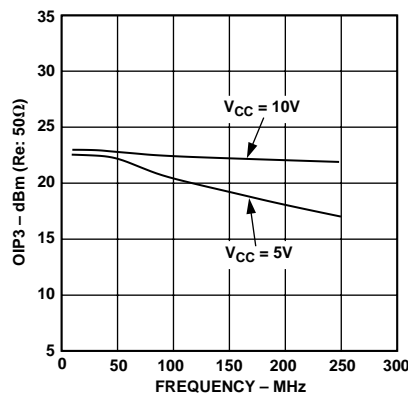

Figure 17. AD8350-20 Output Referred IP3 vs. Frequency

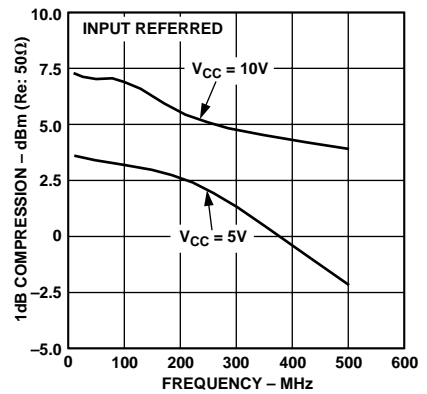

Figure 18. AD8350-15 1 dB Compression vs. Frequency

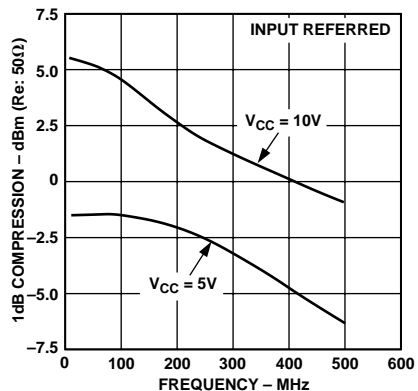

Figure 19. AD8350-20 1 dB Compression vs. Frequency

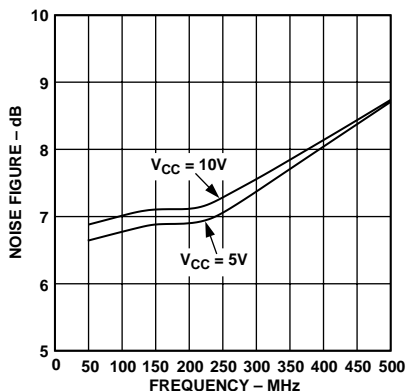

Figure 20. AD8350-15 Noise Figure vs. Frequency

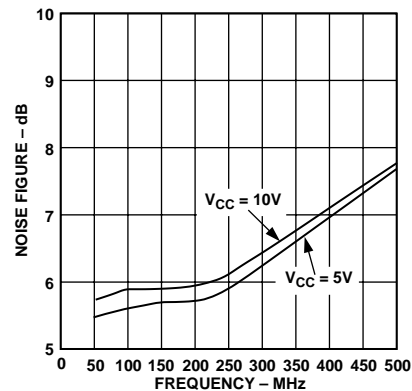

Figure 21. AD8350-20 Noise Figure vs. Frequency

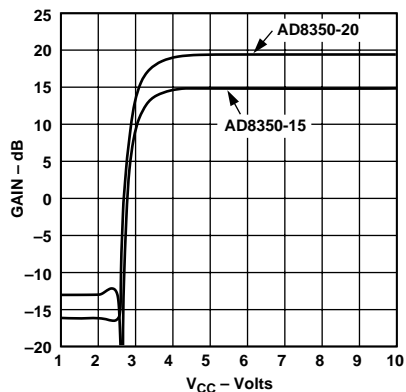

Figure 22. AD8350 Gain (S21) vs. Supply Voltage

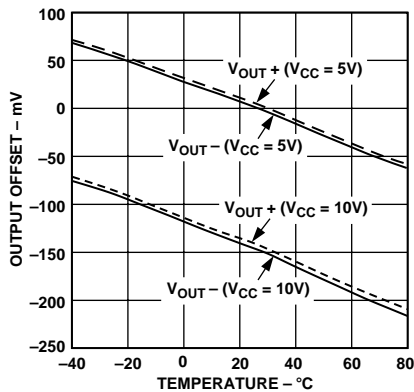

Figure 23. AD8350 Output Offset Voltage vs. Temperature

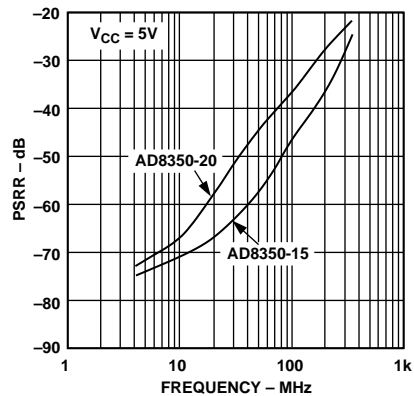

Figure 24. AD8350 PSRR vs. Frequency

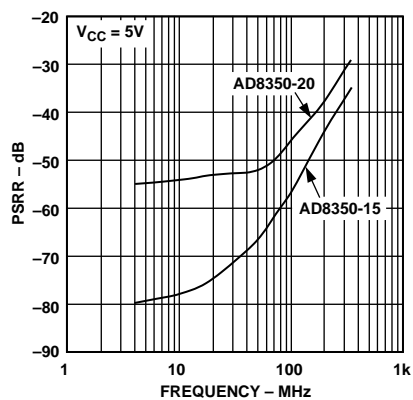

Figure 25. AD8350 CMRR vs. Frequency

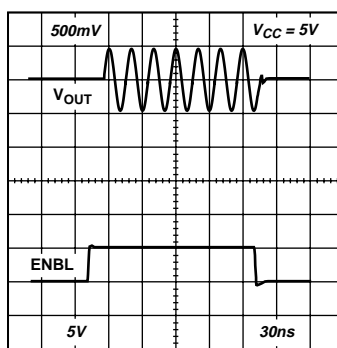

Figure 26. AD8350 Power-Up/Down Response Time

AD8350

APPLICATIONS

Using the AD8350

Figure 27 shows the basic connections for operating the AD8350. A single supply in the range +5 V to +10 V is required. The power supply pin should be decoupled using a 0.1 μF capacitor. The ENBL pin is tied to the positive supply or to +5 V (when $V_{\text{CC}} = +10\text{ V}$) for normal operation and should be pulled to ground to put the device in sleep mode. Both the inputs and the outputs have dc bias levels at midsupply and should be ac-coupled.

Also shown, in Figure 27, are the impedance balancing requirements, either resistive or reactive, of the input and output. With an input and output impedance of 200 Ω , the AD8350 should be driven by a 200 Ω source and loaded by a 200 Ω impedance. A reactive match can also be implemented.

Figure 28 shows how the AD8350 can be driven by a single-ended source. The unused input should be ac-coupled to ground. When driven single-ended, there will be a slight imbalance in the differential output voltages. This will cause an increase in the second order harmonic distortion (at 50 MHz, with $V_{\text{CC}} = +10\text{ V}$ and $V_{\text{OUT}} = 1\text{ V p-p}$, -59 dBc was measured for the second harmonic on AD8350-15).

Reactive Matching

In practical applications, the AD8350 will most likely be matched using reactive matching components as shown in Figure 29. Matching components can be calculated using a Smith Chart and the AD8350's S-Parameters (see Tables I and II) along with those of the devices that are driving and loading it. The S-Parameters in Tables I and II assume a differential source and load impedance of 50 Ω . Because the load impedance on the output of the AD8350 affects the input impedance, a simultaneous conjugate match must be performed to correctly match both input and output.

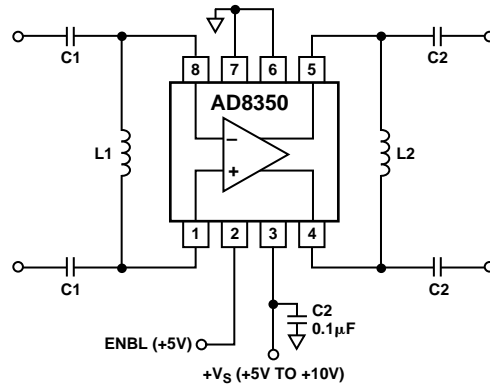

Figure 29. Reactively Matching the Input and Output

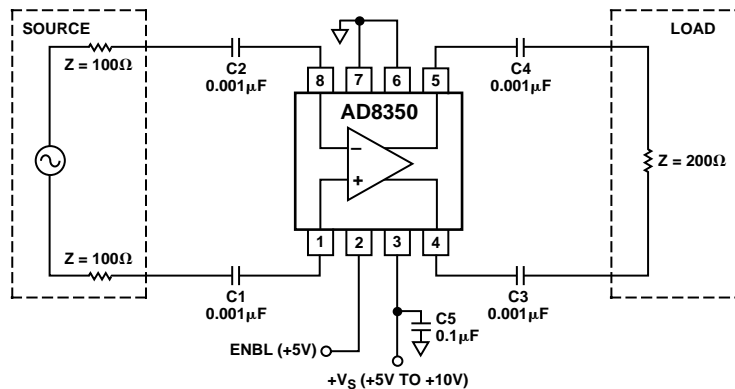

Figure 27. Basic Connections for Differential Drive

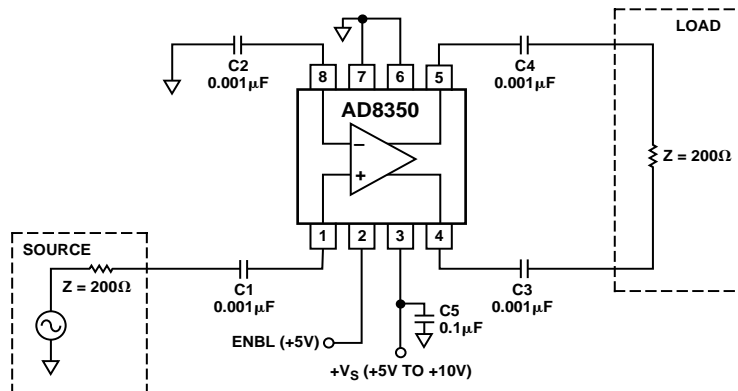

Figure 28. Basic Connections for Single-Ended Drive

Figure 30 shows how the AD8350 input can be matched for a single-ended drive. The unused input is ac-coupled to ground using a low impedance (i.e., high value) capacitance. The S-Parameters for this configuration are shown in Tables III and IV. These values assume a single-ended source impedance of $50\ \Omega$ and a differential load impedance of $50\ \Omega$. As in the case of a differential drive, a simultaneous conjugate match must be performed to correctly match both input and output.

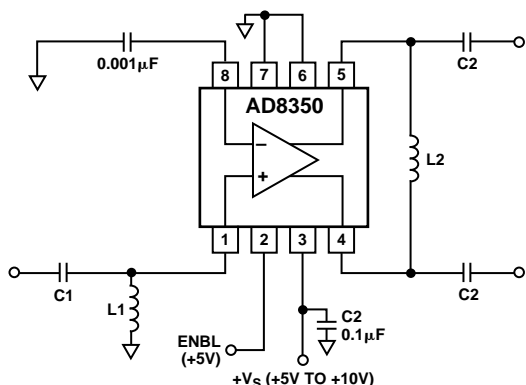

Figure 30. Matching Circuit for Single-Ended Drive

Evaluation Board

Figure 31 shows the schematic of the AD8350 evaluation board as it is shipped from the factory. The board is configured to allow easy evaluation using single-ended $50\ \Omega$ test equipment. The input and output transformers have a 4-to-1 impedance ratio and transform the AD8350's $200\ \Omega$ input and output impedances to $50\ \Omega$. In this mode, $0\ \Omega$ resistors (R1 and R4) are required.

To allow compensation for the insertion loss of the transformers, a calibration path is provided at Test In and Test Out. This consists of two transformers connected back to back.

To drive and load the board differentially, transformers T1 and T2 should be removed and replaced with four $0\ \Omega$ resistors (0805 size); Resistors R1 and R4 ($0\ \Omega$) should also be removed. This yields a circuit with a broadband input and output impedance of $200\ \Omega$. To match to impedances other than this, matching components (0805 size) can be placed on pads C1, C2, C3, C4, L1 and L2.

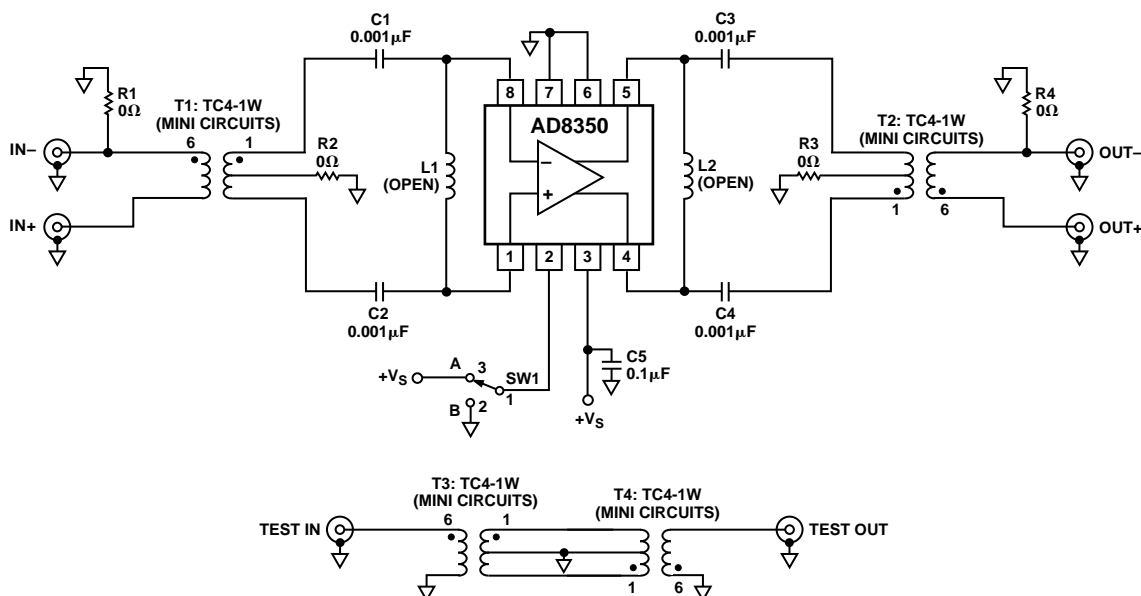

Figure 31. AD8350 Evaluation Board

Table I. Typical S Parameters AD8350-15: $V_{CC} = 5$ V, Differential Input Signal.
 $Z_{SOURCE}(diff) = 50 \Omega$, $Z_{LOAD}(diff) = 50 \Omega$

Frequency (MHz)	S11	S12	S21	S22
50	0.791 $\angle -3^\circ$	0.068 $\angle 177^\circ$	2.73 $\angle -3^\circ$	0.795 $\angle -2^\circ$
100	0.787 $\angle -6^\circ$	0.071 $\angle 174^\circ$	2.79 $\angle -7^\circ$	0.794 $\angle -5^\circ$
150	0.778 $\angle -9^\circ$	0.070 $\angle 172^\circ$	2.91 $\angle -11^\circ$	0.787 $\angle -7^\circ$
200	0.766 $\angle -13^\circ$	0.072 $\angle 168^\circ$	3.06 $\angle -16^\circ$	0.779 $\angle -10^\circ$
250	0.749 $\angle -17^\circ$	0.074 $\angle 165^\circ$	3.24 $\angle -21^\circ$	0.768 $\angle -12^\circ$

Table II. Typical S Parameters AD8350-20: $V_{CC} = 5$ V, Differential Input Signal.
 $Z_{SOURCE}(diff) = 50 \Omega$, $Z_{LOAD}(diff) = 50 \Omega$

Frequency (MHz)	S11	S12	S21	S22
50	0.810 $\angle -4^\circ$	0.046 $\angle 176^\circ$	4.82 $\angle -2.5^\circ$	0.822 $\angle -3^\circ$
100	0.795 $\angle -8^\circ$	0.043 $\angle 173^\circ$	4.99 $\angle -6.16^\circ$	0.809 $\angle -5^\circ$
150	0.790 $\angle -12^\circ$	0.045 $\angle 169^\circ$	5.30 $\angle -9.82^\circ$	0.807 $\angle -8^\circ$
200	0.776 $\angle -17^\circ$	0.046 $\angle 165^\circ$	5.71 $\angle -14.89^\circ$	0.795 $\angle -10^\circ$
250	0.757 $\angle -22^\circ$	0.048 $\angle 162^\circ$	6.25 $\angle -21.29^\circ$	0.783 $\angle -13^\circ$

Table III. Typical S Parameters AD8350-15: $V_{CC} = 5$ V, Single-Ended Input Signal.
 $Z_{SOURCE}(diff) = 50 \Omega$, $Z_{LOAD}(diff) = 50 \Omega$

Frequency (MHz)	S11	S12	S21	S22
50	0.718 $\angle -6^\circ$	0.068 $\angle 177^\circ$	2.62 $\angle -4^\circ$	0.798 $\angle -3^\circ$
100	0.701 $\angle -12^\circ$	0.066 $\angle 173^\circ$	2.66 $\angle -10^\circ$	0.794 $\angle -6^\circ$
150	0.683 $\angle -19^\circ$	0.067 $\angle 167^\circ$	2.76 $\angle -15^\circ$	0.789 $\angle -10^\circ$
200	0.657 $\angle -24^\circ$	0.069 $\angle 163^\circ$	2.86 $\angle -22^\circ$	0.776 $\angle -13^\circ$
250	0.625 $\angle -31^\circ$	0.070 $\angle 159^\circ$	2.98 $\angle -28^\circ$	0.763 $\angle -16^\circ$

Table IV. Typical S Parameters AD8350-20: $V_{CC} = 5$ V, Single-Ended Input Signal.
 $Z_{SOURCE}(diff) = 50 \Omega$, $Z_{LOAD}(diff) = 50 \Omega$

Frequency (MHz)	S11	S12	S21	S22
50	0.747 $\angle -7^\circ$	0.040 $\angle 175^\circ$	4.71 $\angle -4^\circ$	0.814 $\angle -3^\circ$
100	0.739 $\angle -14^\circ$	0.042 $\angle 170^\circ$	4.82 $\angle -9^\circ$	0.813 $\angle -6^\circ$
150	0.728 $\angle -21^\circ$	0.044 $\angle 166^\circ$	5.08 $\angle -15^\circ$	0.804 $\angle -10^\circ$
200	0.698 $\angle -29^\circ$	0.045 $\angle 161^\circ$	5.37 $\angle -22^\circ$	0.792 $\angle -13^\circ$
250	0.659 $\angle -37^\circ$	0.048 $\angle 156^\circ$	5.76 $\angle -30^\circ$	0.774 $\angle -16^\circ$

OUTLINE DIMENSIONS

Dimensions shown in inches and (mm).

**8-Lead Plastic SOIC
(SO-8)**

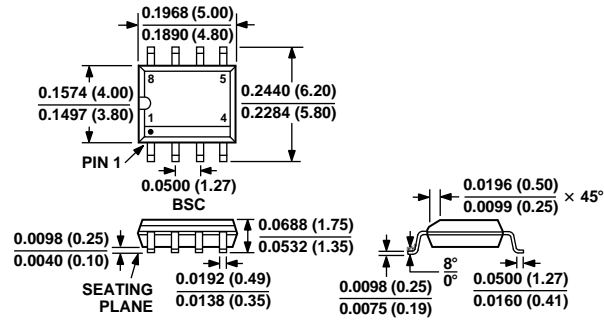

C3577-8-4/99

PRINTED IN U.S.A.