

8-STAGE STATIC SHIFT REGISTERS

4014B SYNCHRONOUS PARALLEL OR SERIAL INPUT/SERIAL OUTPUT

4021B ASYNCHRONOUS PARALLEL INPUT OR SYNCHRONOUS SERIAL INPUT/SERIAL OUTPUT

- MEDIUM-SPEED OPERATION-12MHz (typ.) CLOCK RATE AT $V_{DD} - V_{SS} = 10V$
- FULLY STATIC OPERATION
- 8 MASTER-SLAVE FLIP-FLOPS PLUS OUTPUT BUFFERING AND CONTROL GATING
- QUIESCENT CURRENT SPECIFIED TO 20V FOR HCC DEVICE
- 5V, 10V AND 15V PARAMETRIC RATINGS
- INPUT CURRENT OF 100nA AT 18V AND 25°C FOR HCC DEVICE
- 100% TESTED FOR QUIESCENT CURRENT
- MEETS ALL REQUIREMENTS OF JEDEC TENTATIVE STANDARD N° 13A, "STANDARD SPECIFICATIONS FOR DESCRIPTION OF "B" SERIES CMOS DEVICES"

DESCRIPTION

The **HCC4014B**, **HCC4021B** (extended temperature range) and the **HCF4014B**, **HCF4021B** (intermediate temperature range) are monolithic integrated circuits, available in 16-lead dual in-line plastic or ceramic package and plastic micro package. The **HCC/HCF4014B** and **HCC/HCF4021B** seriestypes are 8-stage parallel-or serial-input/serial-output registers having common CLOCK and PARALLEL/SERIAL CONTROL inputs, a single SERIAL data input, and individual parallel "JAM" inputs to each register stage. Each register stage is a D type, master-slave flip-flop in addition to an output from stage 8, "Q" outputs are also available from stages 6 and 7. Parallel as well as serial entry is made into the register synchronously with the positive clock line transition in the **HCC/HCF4014B**. In the **HCC/HCF4021B** serial entry is synchronous with the clock but parallel entry is asynchronous. In both types, entry is controlled by the PARALLEL/SERIAL CONTROL input. When the PARALLEL/SERIAL CONTROL input is low, data is serially shifted into the 8-stage register synchronously with the positive transition of the clock line. When the PARALLEL/SERIAL CONTROL input is high, data is jammed into the 8-stage register via the parallel input

lines and synchronous with the positive transition of the clock line. In the **HCC/HCF4021B**, the CLOCK input of the internal stage is "forced" when asynchronous parallel entry is made. Register expansion using multiple package is permitted.

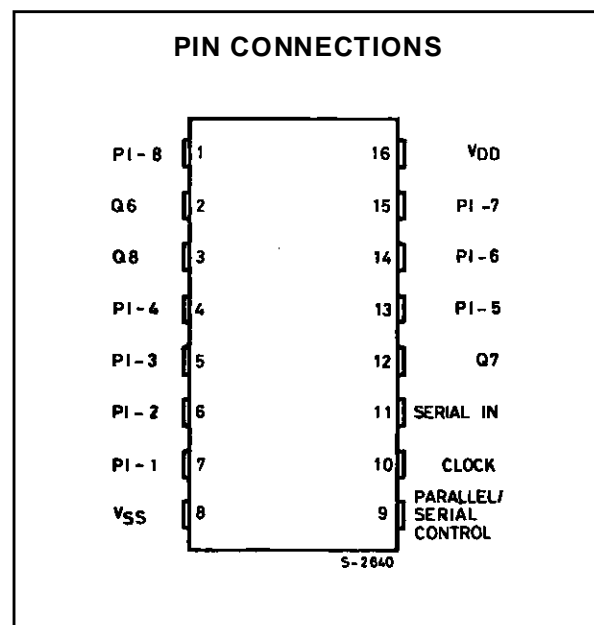
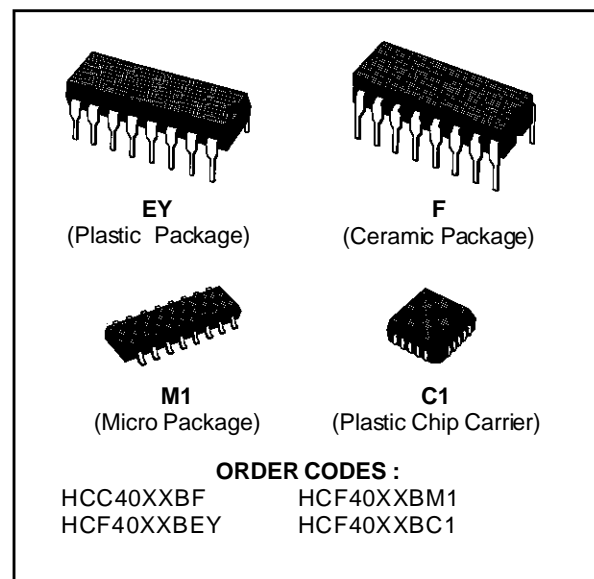

FUNCTIONAL DIAGRAM

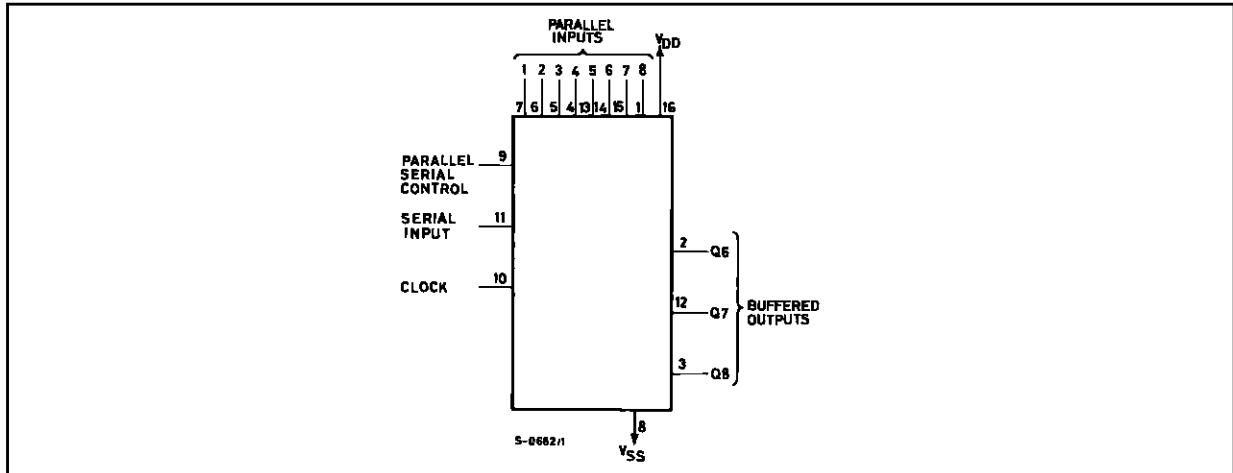

ABSOLUTE MAXIMUM RATINGS

Symbol	Parameter	Value	Unit
V_{DD}^*	Supply Voltage : HCC Types HCF Types	- 0.5 to + 20 - 0.5 to + 18	V V
V_i	Input Voltage	- 0.5 to $V_{DD} + 0.5$	V
I_i	DC Input Current (any one input)	± 10	mA
P_{tot}	Total Power Dissipation (per package) Dissipation per Output Transistor for $T_{op} =$ Full Package-temperature Range	200 100	mW mW
T_{op}	Operating Temperature : HCC Types HCF Types	- 55 to + 125 - 40 to + 85	$^{\circ}C$ $^{\circ}C$
T_{stg}	Storage Temperature	- 65 to + 150	$^{\circ}C$

Stresses above those listed under "Absolute Maximum Ratings" may cause permanent damage to the device. This is a stress rating only and functional operation of the device at these or any other conditions above those indicated in the operational sections of this specification is not implied. Exposure to absolute maximum rating conditions for external periods may affect device reliability.

* All voltage values are referred to V_{SS} pin voltage.

RECOMMENDED OPERATING CONDITIONS

Symbol	Parameter	Value	Unit
V_{DD}	Supply Voltage : HCC Types HCF Types	3 to 18 3 to 15	V V
V_i	Input Voltage	0 to V_{DD}	V
T_{op}	Operating Temperature : HCC Types HCF Types	- 55 to + 125 - 40 to + 85	$^{\circ}C$ $^{\circ}C$

LOGIC DIAGRAMS

4014B

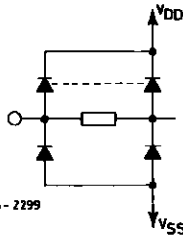
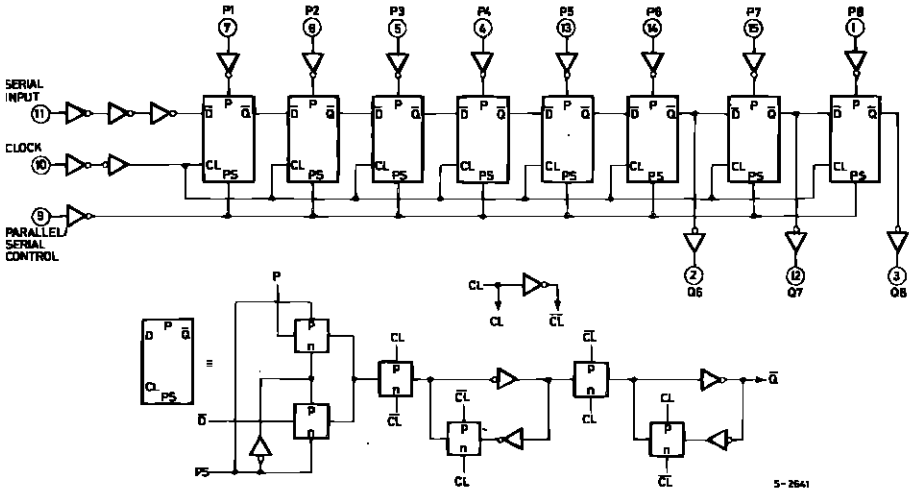

ALL INPUTS ARE PROTECTED BY COS/MOS PROTECTION NETWORK

4021B

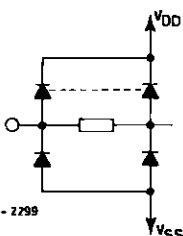
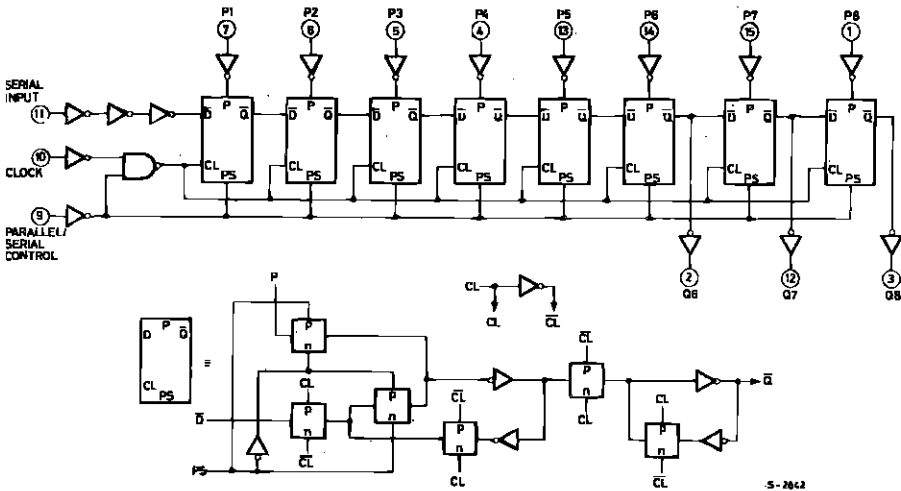

ALL INPUTS ARE PROTECTED BY COS/MOS PROTECTION NETWORK

HCC/HCF4014B/4021B

TRUTH TABLES

HCC/HCF 4014B

CL	Serial Input	Parallel/Serial Control	PI-1	PI-n	Q ₁ (internal)	Q _n
	X	1	0	0	0	0
	X	1	1	0	1	0
	X	1	0	1	0	1
	X	1	1	1	1	1
	0	0	X	X	0	Q _{n-1}
	1	0	X	X	1	Q _{n-1}
	X	X	X	X	Q ₁	Q _n

X = don't care case.
NC = no change.

HCC/HCF4021B

CL	Serial Input	Parallel/Serial Control	PI-1	PI-n	Q ₁ (internal)	Q _n
X	X	1	0	0	0	0
X	X	1	0	1	0	1
X	X	1	1	0	1	0
X	X	1	1	1	1	1
	0	0	X	X	0	Q _{n-1}
	1	0	X	X	1	Q _{n-1}
	X	0	X	X	Q ₁	Q _n

X = don't care case.
NC = no change.

STATIC ELECTRICAL CHARACTERISTICS (over recommended operating conditions)

Symbol	Parameter	Test Conditions				Value						Unit			
		V _I (V)	V _O (V)	I _O (μA)	V _{DD} (V)	T _{Low} *		25°C			T _{High} *				
						Min.	Max.	Min.	Typ.	Max.	Min.		Max.		
I _L	Quiescent Current				5	-55°C		25°C			+85°C		μA		
						HCC Types	0/5			5	5	0.04		5	150
							0/10			10	10	0.04		10	300
							0/15			15	20	0.04		20	600
							0/20			20	100	0.08		100	3000
						HCF Types	0/5			5	20	0.04		20	150
0/10			10	40	0.04		40	300							
0/15			15	80	0.04		80	600							
V _{OH}	Output High Voltage			< 1	5	-55°C		25°C			+85°C		V		
						0/5			4.95	4.95	4.95				
						0/10			9.95	9.95	9.95				
V _{OL}	Output Low Voltage			< 1	5	-55°C		25°C			+85°C		V		
						5/0			0.05	0.05	0.05				
						10/0			0.05	0.05	0.05				
V _{IH}	Input High Voltage			< 1	5	-55°C		25°C			+85°C		V		
						0.5/4.5			3.5	3.5	3.5				
						1/9			7	7	7				
V _{IL}	Input Low Voltage			< 1	5	-55°C		25°C			+85°C		V		
						4.5/0.5			1.5	1.5	1.5				
						9/1			3	3	3				
				< 1	15	-55°C		25°C			+85°C				
						13.5/1.5			4	4	4				

* T_{Low} = -55°C for HCC device; -40°C for HCF device.

* T_{High} = +125°C for HCC device; +85°C for HCF device.

The Noise Margin for both "1" and "0" level is: 1V min. with V_{DD} = 5V, 2V min. with V_{DD} = 10V, 2.5 V min. with V_{DD} = 15V.

STATIC ELECTRICAL CHARACTERISTICS (continued)

Symbol	Parameter	Test Conditions				Value						Unit	
		V _I (V)	V _O (V)	I _O (μ A)	V _{DD} (V)	T _{Low} *		25°C			T _{High} *		
						Min.	Max.	Min.	Typ.	Max.	Min.		Max.
I _{OH}	Output Drive Current	HCC Types	0/ 5	2.5		5	- 2		- 1.6	- 3.2		- 1.15	mA
			0/ 5	4.6		5	- 0.64		- 0.51	- 1		- 0.36	
			0/10	9.5		10	- 1.6		- 1.3	- 2.6		- 0.9	
			0/15	13.5		15	- 4.2		- 3.4	- 6.8		- 2.4	
		HCF Types	0/ 5	2.5		5	- 1.53		- 1.36	- 3.2		- 1.1	
			0/ 5	4.6		5	- 0.52		- 0.44	- 1		- 0.36	
			0/10	9.5		10	- 1.3		- 1.1	- 2.6		- 0.9	
			0/15	13.5		15	- 3.6		- 3.0	- 6.8		- 2.4	
I _{OL}	Output Sink Current	HCC Types	0/ 5	0.4		5	0.64		0.51	1		0.36	mA
			0/10	0.5		10	1.6		1.3	2.6		0.9	
			0/15	1.5		15	4.2		3.4	6.8		2.4	
		HCF Types	0/ 5	0.4		5	0.52		0.44	1		0.36	
			0/10	0.5		10	1.3		1.1	2.6		0.9	
			0/15	1.5		15	3.6		3.0	6.8		2.4	
I _{IH} , I _{IL}	Input Leakage Current	HCC Types	0/18	Any Input	18		± 0.1		$\pm 10^{-5}$	± 0.1		± 1	μ A
		HCF Types	0/15		15		± 0.3		$\pm 10^{-5}$	± 0.3		± 1	
C _I	Input Capacitance		Any Input						5	7.5		pF	

* T_{Low} = -55°C for HCC device : - 40°C for HCF device.* T_{High} = + 125°C for HCC device : + 85°C for HCF device.The Noise Margin for both "1" and "0" level is : 1V min. with V_{DD} = 5V, 2V min. with V_{DD} = 10V, 2.5 V min. with V_{DD} = 15V.DYNAMIC ELECTRICAL CHARACTERISTICS (T_{amb} = 25°C, C_L = 50pF, R_L = 200k Ω , typical temperature coefficient for all V_{DD} = 0.3%/°C values, all input rise and fall time = 20ns)

Symbol	Parameter	Test Conditions		Value			Unit
			V _{DD} (V)	Min.	Typ.	Max.	
CLOCKED OPERATION							
t _{PLH} , t _{PHL}	Propagation Delay Time		5		160	320	ns
			10		80	160	
			15		60	120	
t _{THL} , t _{TLH}	Transition Time		5		100	200	ns
			10		50	100	
			15		40	80	
f _{CL} *	Maximum Clock Input Frequency		5	3	6		MHz
			10	6	12		
			15	8.5	17		
t _w	Clock Pulse Width		5	180	90		ns
			10	80	40		
			15	50	25		

* If more than one unit is cascaded t_{CL} should be made less than or equal to the sum of the transition time and the fixed propagation delay of the output of the driving stage of the estimated capacitive load.

DYNAMIC ELECTRICAL CHARACTERISTICS (Continued)

Symbol	Parameter	Test Conditions		Value			Unit
			V _{DD} (V)	Min.	Typ.	Max.	
CLOCKED OPERATION							
t _r , t _f	Clock Input Rise or Fall Time		5			15	μs
			10			15	
			15			15	
t _{setup}	Setup Time, serial Input (ref. to CL)		5	120	60		ns
			10	80	40		
			15	60	30		
t _{setup}	Setup Time, parallel Input (4014B) (ref. to CL)		5	80	40		ns
			10	50	25		
			15	40	20		
t _{setup}	Setup Time, parallel Input (4021B) (ref. to P/S)		5	50	25		ns
			10	30	15		
			15	20	10		
t _{setup}	Setup Time, parallel/serial Control (4014B) (ref. to CL)		5	180	90		ns
			10	80	40		
			15	60	30		
t _{hold}	Hold Time, serial in, parallel in, parallel/serial Control		5	0			ns
			10	0			
			15	0			
t _{WH}	P/S Pulse Width (4021B)		5	160	80		ns
			10	80	40		
			15	50	25		
t _{rem}	P/S Removal time (4021B) (ref. to CL)		5	280	140		ns
			10	140	70		
			15	100	50		

* If more than one unit is cascaded t_{CL} should be made less than or equal to the sum of the transition time and the fixed propagation delay of the output of the driving stage of the estimated capacitive load.

Typical Output Low (sink) Current Characteristics.

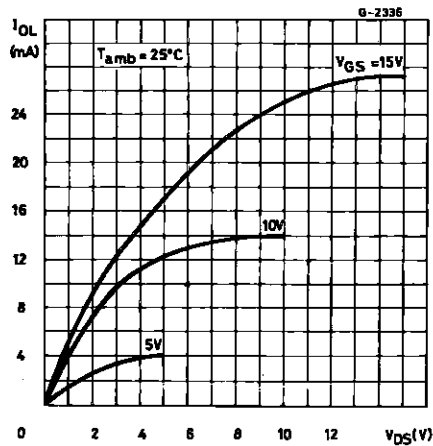

Minimum Output Low (sink) Current Characteristics.

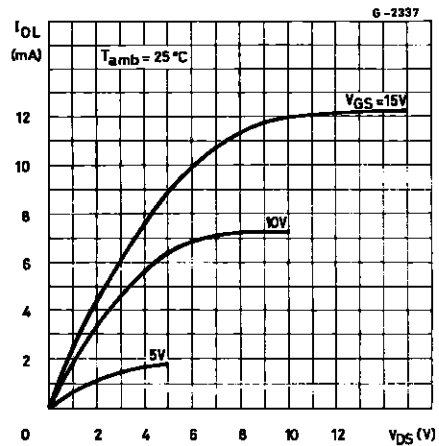

Typical Output High (source) Current Characteristics.

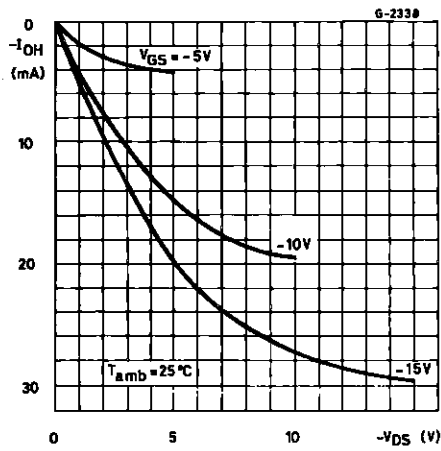

Minimum Output High (source) Current Characteristics.

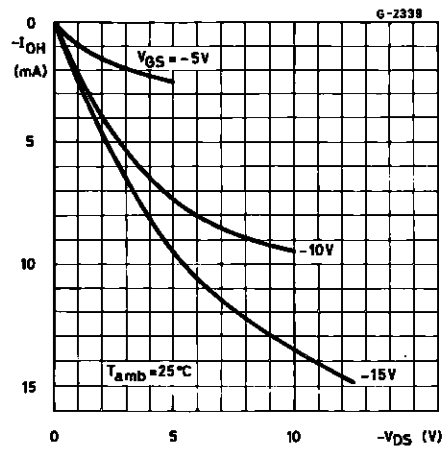

Typical Transition Time vs. Load Capacitance.

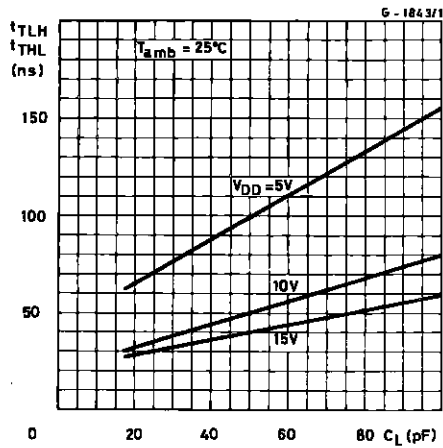

Typical Propagation Delay Time vs. Load Capacitance.

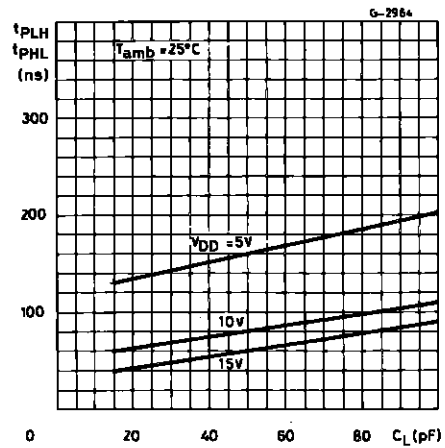

Typical Dynamic Power Dissipating vs. Clock Input Frequency.

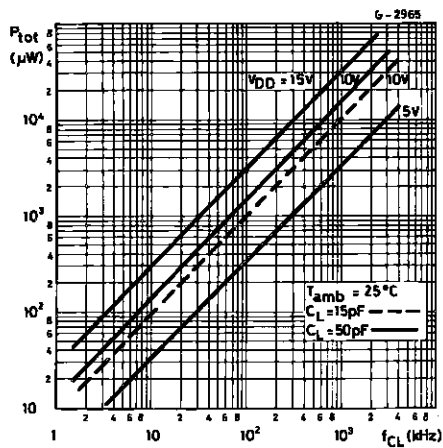

TEST CIRCUITS

Quiescent Device Current.

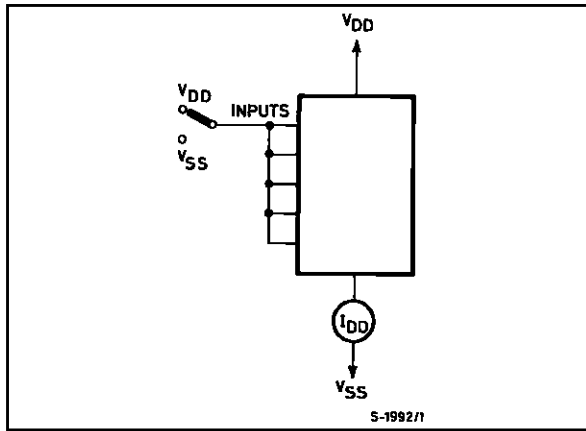

Noise Immunity.

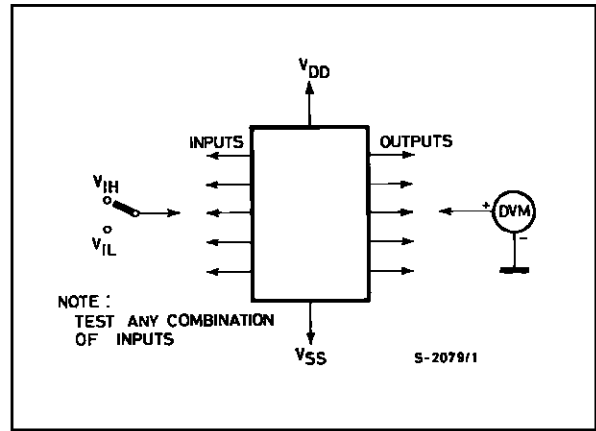

Input Leakage Current.

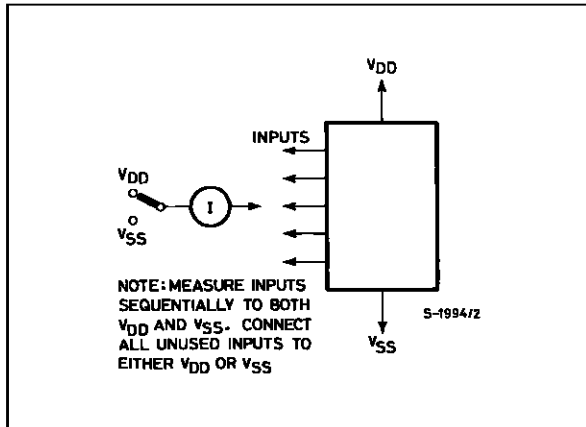

Dynamic Power Dissipation.

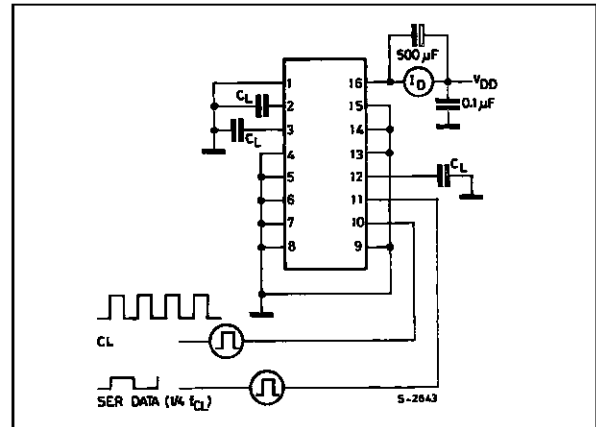

Plastic DIP16 (0.25) MECHANICAL DATA

DIM.	mm			inch		
	MIN.	TYP.	MAX.	MIN.	TYP.	MAX.
a1	0.51			0.020		
B	0.77		1.65	0.030		0.065
b		0.5			0.020	
b1		0.25			0.010	
D			20			0.787
E		8.5			0.335	
e		2.54			0.100	
e3		17.78			0.700	
F			7.1			0.280
I			5.1			0.201
L		3.3			0.130	
Z			1.27			0.050

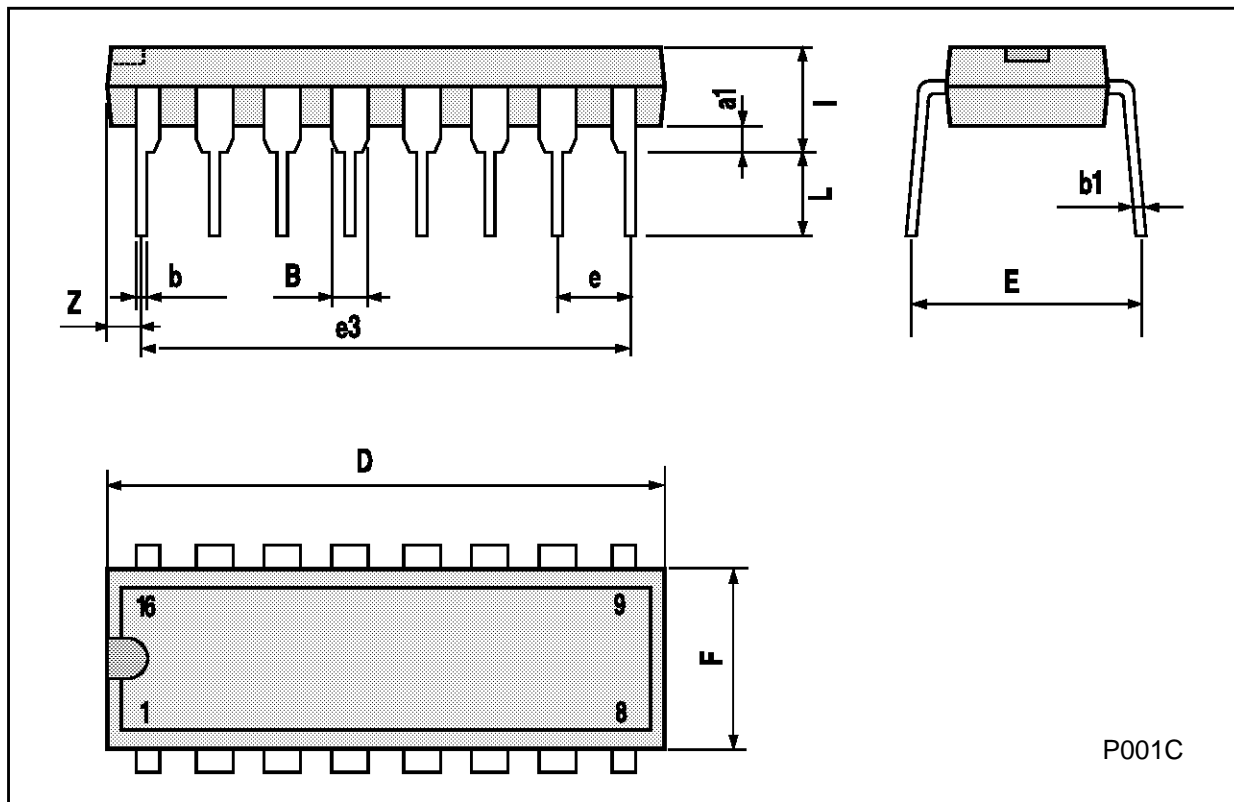

Ceramic DIP16/1 MECHANICAL DATA

DIM.	mm			inch		
	MIN.	TYP.	MAX.	MIN.	TYP.	MAX.
A			20			0.787
B			7			0.276
D		3.3			0.130	
E	0.38			0.015		
e3		17.78			0.700	
F	2.29		2.79	0.090		0.110
G	0.4		0.55	0.016		0.022
H	1.17		1.52	0.046		0.060
L	0.22		0.31	0.009		0.012
M	0.51		1.27	0.020		0.050
N			10.3			0.406
P	7.8		8.05	0.307		0.317
Q			5.08			0.200

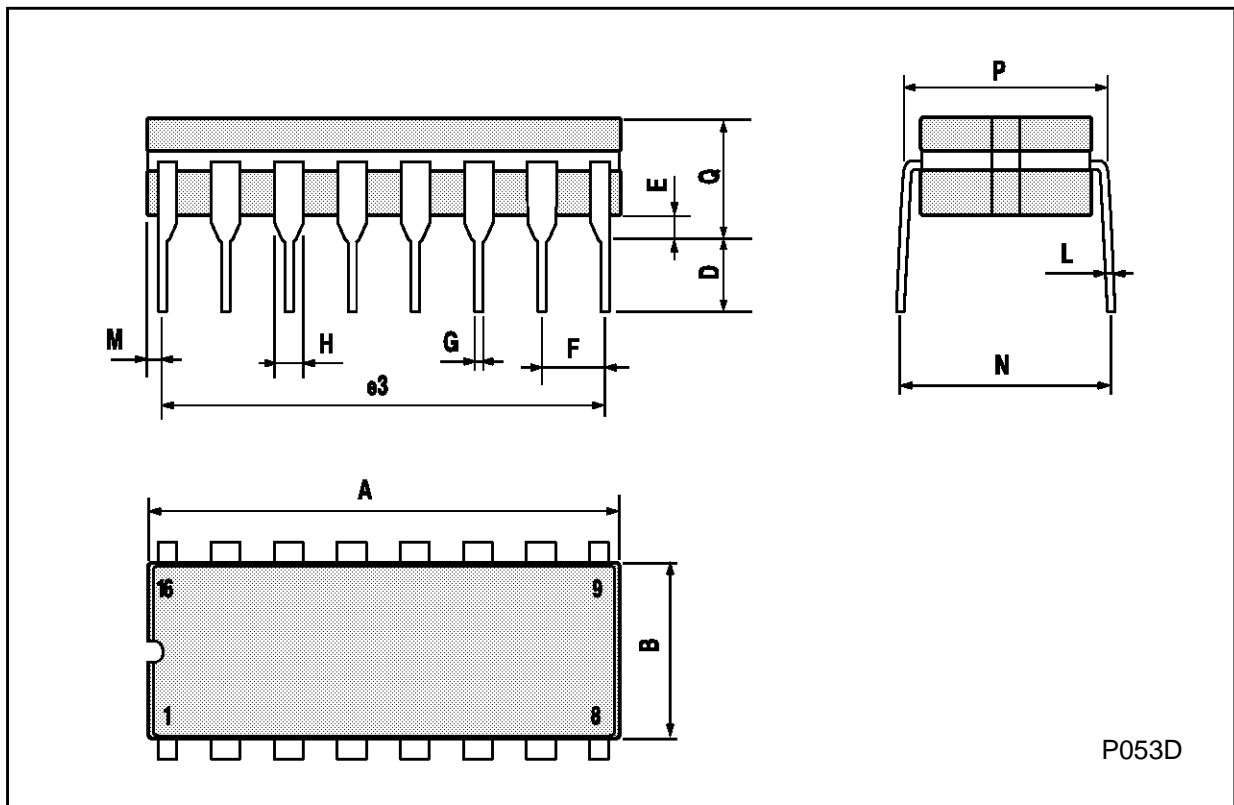

SO16 (Narrow) MECHANICAL DATA

DIM.	mm			inch		
	MIN.	TYP.	MAX.	MIN.	TYP.	MAX.
A			1.75			0.068
a1	0.1		0.2	0.004		0.007
a2			1.65			0.064
b	0.35		0.46	0.013		0.018
b1	0.19		0.25	0.007		0.010
C		0.5			0.019	
c1	45° (typ.)					
D	9.8		10	0.385		0.393
E	5.8		6.2	0.228		0.244
e		1.27			0.050	
e3		8.89			0.350	
F	3.8		4.0	0.149		0.157
G	4.6		5.3	0.181		0.208
L	0.5		1.27	0.019		0.050
M			0.62			0.024
S	8° (max.)					

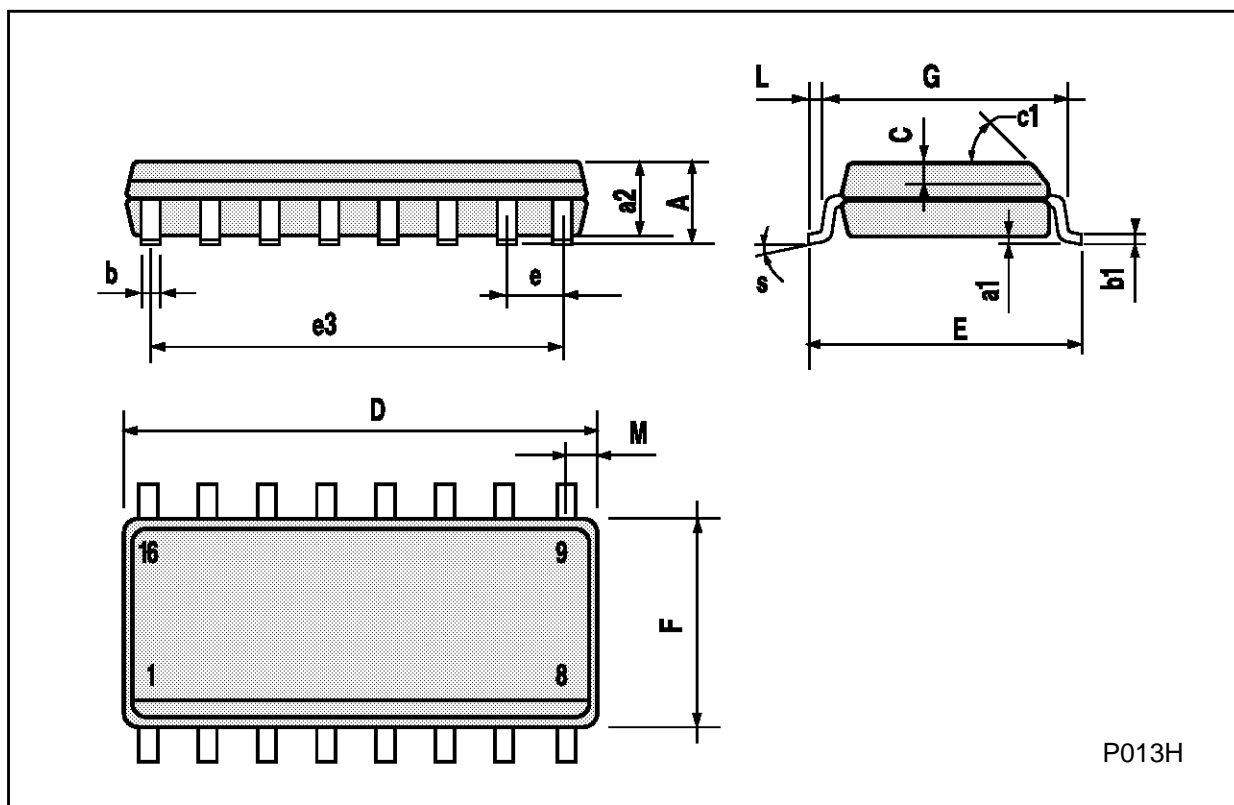

PLCC20 MECHANICAL DATA

DIM.	mm			inch		
	MIN.	TYP.	MAX.	MIN.	TYP.	MAX.
A	9.78		10.03	0.385		0.395
B	8.89		9.04	0.350		0.356
D	4.2		4.57	0.165		0.180
d1		2.54			0.100	
d2		0.56			0.022	
E	7.37		8.38	0.290		0.330
e		1.27			0.050	
e3		5.08			0.200	
F		0.38			0.015	
G			0.101			0.004
M		1.27			0.050	
M1		1.14			0.045	

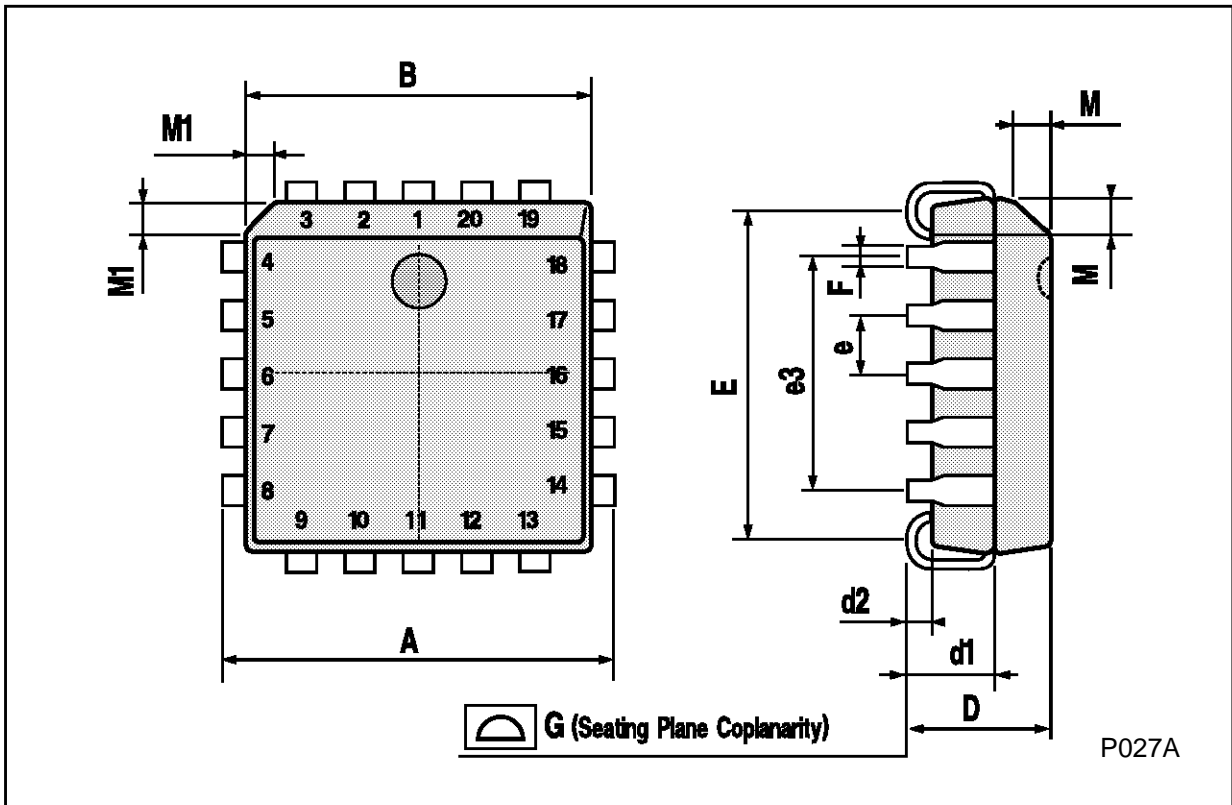

Information furnished is believed to be accurate and reliable. However, SGS-THOMSON Microelectronics assumes no responsibility for the consequences of use of such information nor for any infringement of patents or other rights of third parties which may result from its use. No license is granted by implication or otherwise under any patent or patent rights of SGS-THOMSON Microelectronics. Specifications mentioned in this publication are subject to change without notice. This publication supersedes and replaces all information previously supplied. SGS-THOMSON Microelectronics products are not authorized for use as critical components in life support devices or systems without express written approval of SGS-THOMSON Microelectronics.

© 1996 SGS-THOMSON Microelectronics - Printed in Italy - All Rights Reserved

SGS-THOMSON Microelectronics GROUP OF COMPANIES

Australia - Brazil - Canada - China - France - Germany - Hong Kong - Italy - Japan - Korea - Malaysia - Malta - Morocco - The Netherlands - Singapore - Spain - Sweden - Switzerland - Taiwan - Thailand - United Kingdom - U.S.A

This datasheet has been download from:

www.datasheetcatalog.com

Datasheets for electronics components.