

isc N-Channel MOSFET Transistor

2SK1855

DESCRIPTION

- Drain Current $I_D=12A @ T_C=25^\circ C$
- Drain Source Voltage-
: $V_{DSS}=500V(\text{Min})$
- Fast Switching Speed

APPLICATIONS

- Switching power supply

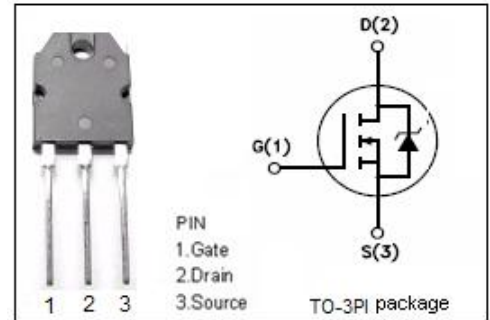

ABSOLUTE MAXIMUM RATINGS($T_a=25^\circ C$)

SYMBOL	PARAMETER	VALUE	UNIT
V_{DSS}	Drain-Source Voltage ($V_{GS}=0$)	500	V
V_{GS}	Gate-Source Voltage	± 30	V
I_D	Drain Current-continuous@ $T_C=25^\circ C$	12	A
P_{tot}	Total Dissipation@ $T_C=25^\circ C$	125	W
T_j	Max. Operating Junction Temperature	150	$^\circ C$
T_{stg}	Storage Temperature Range	-55~150	$^\circ C$

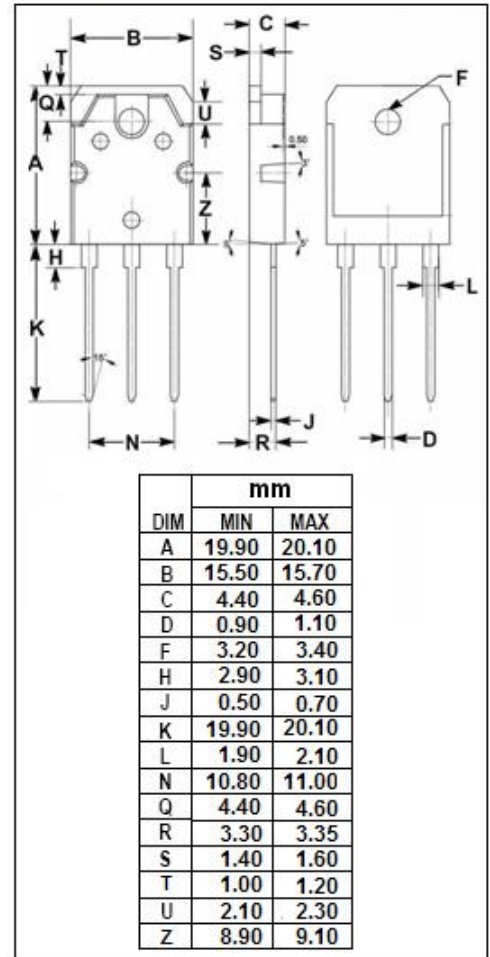

isc N-Channel MOSFET Transistor**2SK1855**• ELECTRICAL CHARACTERISTICS ($T_C=25^\circ\text{C}$)

SYMBOL	PARAMETER	CONDITIONS	MIN	MAX	UNIT
$V_{(BR)DSS}$	Drain-Source Breakdown Voltage	$V_{GS}=0; I_D=1\text{mA}$	500		V
$V_{GS(th)}$	Gate Threshold Voltage	$V_{DS}=V_{GS}; I_D=1\text{mA}$	2.0	4.0	V
$R_{DS(on)}$	Drain-Source On-Resistance	$V_{GS}=10\text{V}; I_D=6\text{A}$		0.7	Ω
I_{GSS}	Gate-Body Leakage Current	$V_{GS}= \pm 30\text{V}; V_{DS}=0$		± 100	nA
I_{DSS}	Zero Gate Voltage Drain Current	$V_{DS}=500\text{V}; V_{GS}=0$		300	μA