

MAX14626

High-Voltage Reverse-Input-Capable 4–20mA Current Loop Protector

General Description

The MAX14626 current loop protector features a current-limit switch to prevent damage to the sensor devices due to faulty current loop conditions. The current-limit switch features a 25Ω (typ) on-resistance and operates from a +2.3V to +36V input voltage range. The accurate current limit is set to 30mA, making the part ideal for protecting the sensor reading devices.

The MAX14626 handles an overcurrent event in a continuous current-limit mode. Additional safety features include thermal shutdown to prevent overheating and reverse-input blocking to protect from being reverse connected into the sensor.

The device is available in a tiny 6-pin (3mm x 3mm), TDFN exposed pad package and is specified over the -40°C to +85°C extended temperature range.

Applications

- Industrial Current Loop Control

Benefits and Features

- High Performance
 - Low On-Resistance 25Ω (typ)
 - Accurate ±10% Current Limit
 - +2.3V to +40V Wide Supply Voltage Range
 - Low Operating Current
 - Ultra-Low Temperature Coefficient
- Robust Protection for Sensors
 - Avoids Power Dissipation Issues Compared to Discrete Solutions
 - Thermal Shutdown
 - Reverse Input Protection
- Saves Space in Compact Systems
 - Eliminates Need for Discrete PTC Poly Switch, Zener Diodes, and Resistors
 - 3mm x 3mm, 6-Pin TDFN Package

Ordering Information appears at end of data sheet.

Typical Operating Circuit

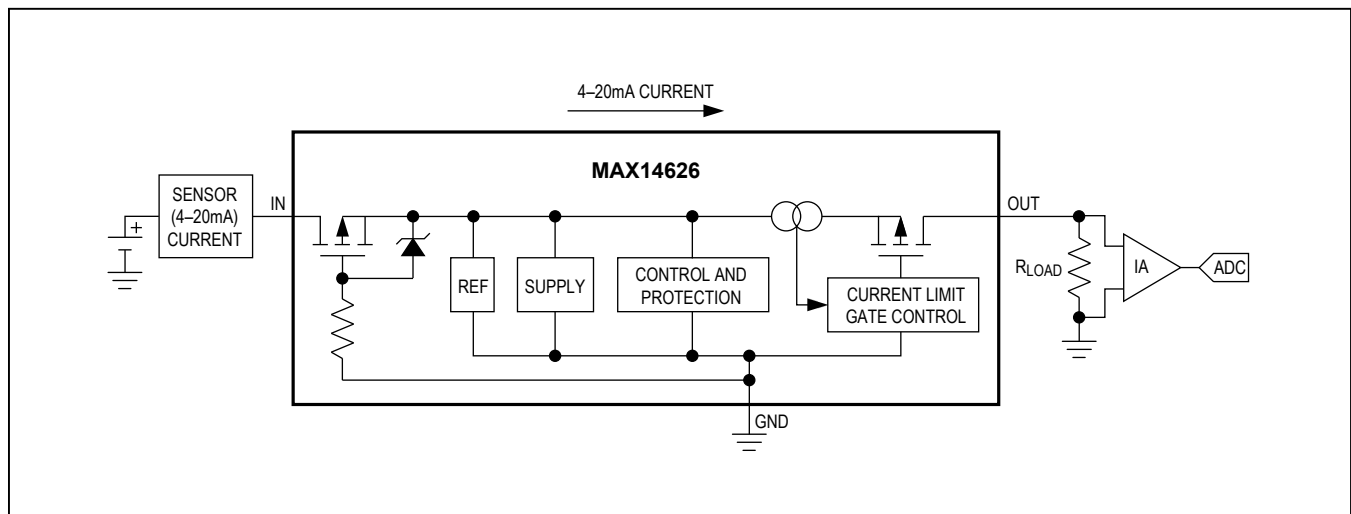

Absolute Maximum Ratings

(All voltages referenced to GND.)

IN to GND.....	-40V to +40V
OUT to GND.....	-0.3V to +40V
Current into IN.....	Internally Limited
Current into OUT.....	100mA
Continuous Power Dissipation ($T_A = +70^\circ\text{C}$) TDFN (derate 23.8mW/°C above +70°C).....	1904.8mW

Operating Temperature Range.....	-40°C to +125°C
Maximum Junction Temperature.....	+150°C
Storage Temperature Range.....	-65°C to +150°C
Lead Temperature (soldering, 10s).....	+300°C
Soldering Temperature (reflow).....	+260°C

Stresses beyond those listed under "Absolute Maximum Ratings" may cause permanent damage to the device. These are stress ratings only, and functional operation of the device at these or any other conditions beyond those indicated in the operational sections of the specifications is not implied. Exposure to absolute maximum rating conditions for extended periods may affect device reliability.

Package Thermal Characteristics (Note 1)

TDFN

Junction-to-Ambient Thermal Resistance (θ_{JA})42°C/W

Junction-to-Case Thermal Resistance (θ_{JC})9°C/W

Note 1: Package thermal resistances were obtained using the method described in JEDEC specification JESD51-7, using a four-layer board. For detailed information on package thermal considerations, refer to www.maximintegrated.com/thermal-tutorial.

DC Electrical Characteristics

($I_{IN} = 50\mu\text{A}$ to 24mA, $T_A = -40^\circ\text{C}$ to +85°C, $R_{LOAD} = 25\Omega$ to 1k Ω , unless otherwise noted. Typical values are at $I_{IN} = 10\text{mA}$, $R_{LOAD} = 250\Omega$, and $T_A = +25^\circ\text{C}$.) (Note 2)

PARAMETER	SYMBOL	CONDITIONS	MIN	TYP	MAX	UNITS
SUPPLY VOLTAGE						
Operating Start Voltage	V_{IN_ST}	$I_{IN} = 20\mu\text{A}$			2.3	V
Operating IN Voltage	V_{IN}				36	V
Operating IN to OUT Drop Voltage		$I_{IN} = 24\text{mA}$			2.8	V
Quiescent Current (Normal Mode: 4–20mA)	I_Q	$R_{LOAD} \leq 250\Omega$		40	56	μA
Quiescent Current (Current-Limit Mode: Current > 25mA)	I_Q	$I_{OUT} = 30\text{mA}$, $V_{IN} = 5\text{V}$, $R_{LOAD} = 25\Omega$			65	μA
Reverse Current	I_{REV}	$V_{IN} = -36\text{V}$, $V_{OUT} = 0\text{V}$, current into OUT		0.01	0.3	μA
IN to OUT Switch On-Resistance	R_{ON}	$V_{IN} = 4\text{V}$, $I_{OUT} = 16\text{mA}$		25	45	Ω
Forward Current Limit	I_{LIM}	$V_{IN} = 36\text{V}$	27	30	33	mA
DYNAMIC						
Turn-On Time	t_{SS}	$V_{IN} = 3\text{V}$, time from V_{IN} applied to $V_{OUT} = 90\%$ of V_{IN} (Note 3)		10		μs
Turn-Off Time	t_{OFF}	Time from thermal shutdown (Note 3)		20		μs
Current-Limit Reaction Time	t_{LIM}	Input current source from 20mA to 50mA (Note 4)		50		μs
Current-Limit Overshoot Voltage		Input current source from 0mA to 50mA		50		%
Input Small Signal Bandwidth	BW	2mA \leq DC $I_{IN} \leq$ 24mA, $D I_{IN} = 1\text{mA}_{P-P}$ at 1k Ω		> 10		kHz

DC Electrical Characteristics (continued)

($I_{IN} = 50\mu A$ to $24mA$, $T_A = -40^{\circ}C$ to $+85^{\circ}C$, $R_{LOAD} = 25\Omega$ to $1k\Omega$, unless otherwise noted. Typical values are at $I_{IN} = 10mA$, $R_{LOAD} = 250\Omega$, and $T_A = +25^{\circ}C$.) (Note 2)

PARAMETER	SYMBOL	CONDITIONS	MIN	TYP	MAX	UNITS
THERMAL PROTECTION						
Thermal Shutdown				+150		$^{\circ}C$
Thermal-Shutdown Hysteresis				20		$^{\circ}C$

Note 2: All devices are 100% production tested at $T_A = +25^{\circ}C$, unless otherwise noted. Limits over the $-40^{\circ}C$ to $+85^{\circ}C$ operating temperature range are guaranteed by design.

Note 3: Turn-on time and turn-off time are defined as the difference in the time between when the output voltage crosses 10% and 90% of the final output voltage.

Note 4: Input current source can support voltage up to $+40V$ (absolute maximum). Current reaction time is defined as the settling time of the output current after a fault event.

Typical Operating Characteristics

($V_{IN} = 24V$, $I_{IN} = 10mA$, $R_{LOAD} = 250\Omega$, unless otherwise noted. Typical values are at $T_A = +25^{\circ}C$.)

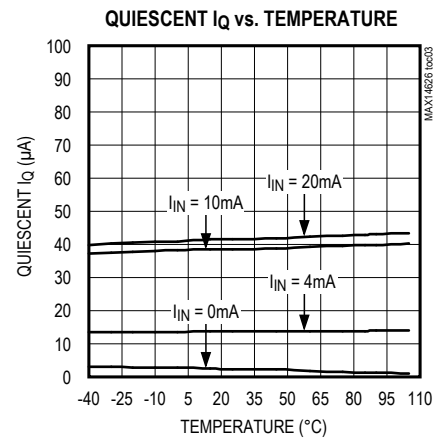
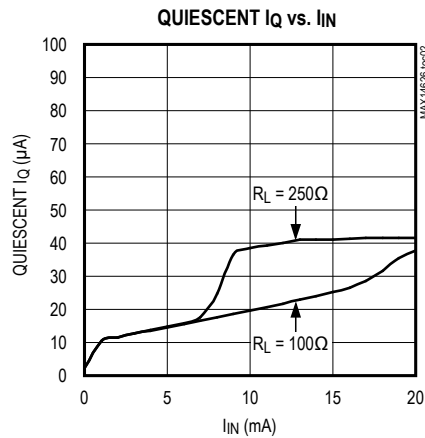
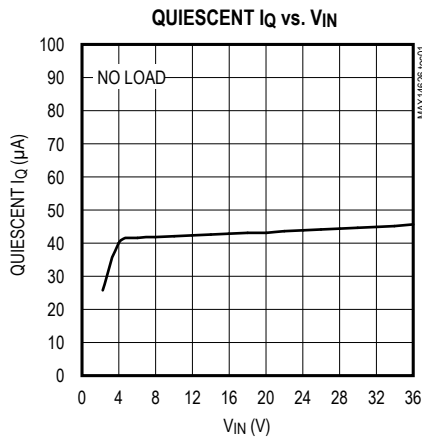

Typical Operating Characteristics (continued)

($V_{IN} = 24V$, $I_{IN} = 10mA$, $R_{LOAD} = 250\Omega$, unless otherwise noted. Typical values are at $T_A = +25^\circ C$.)

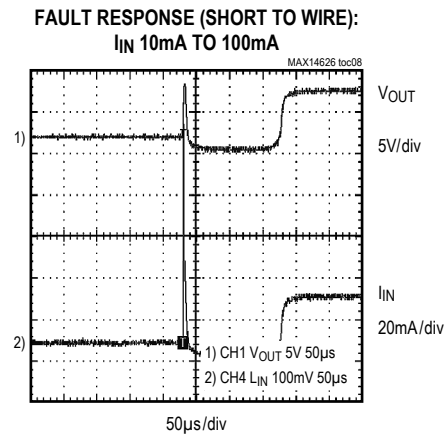
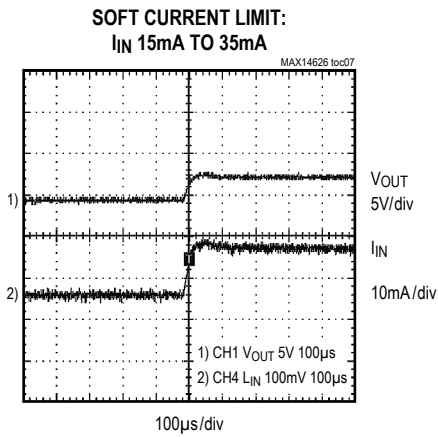
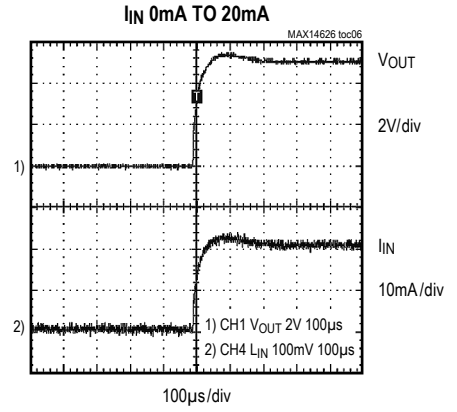
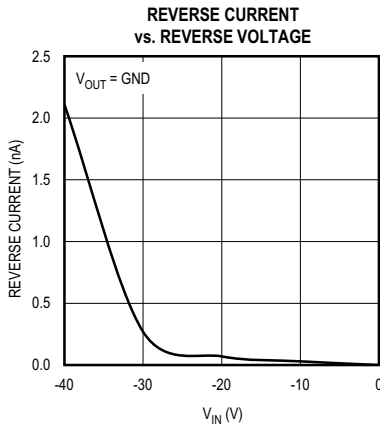
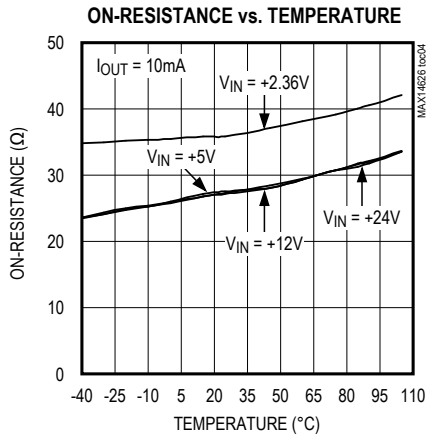

Pin Configuration

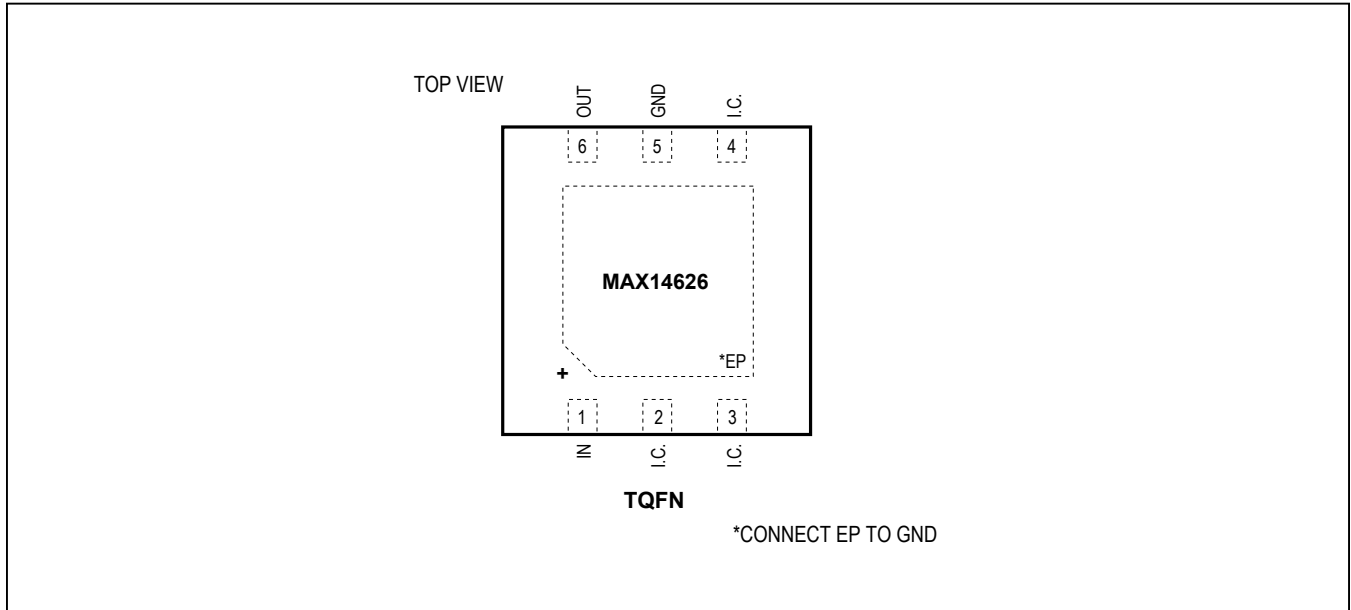

Pin Description

PIN	NAME	FUNCTION
1	IN	Power Input
2, 3, 4	I.C.	Internally Connected. Connect I.C. to GND.
5	GND	Ground
6	OUT	Switch Output
—	EP	Exposed Pad. Connect EP to GND. Connect to a large ground plane to maximize thermal performance. Not intended as an electrical connection point.

Functional Diagram

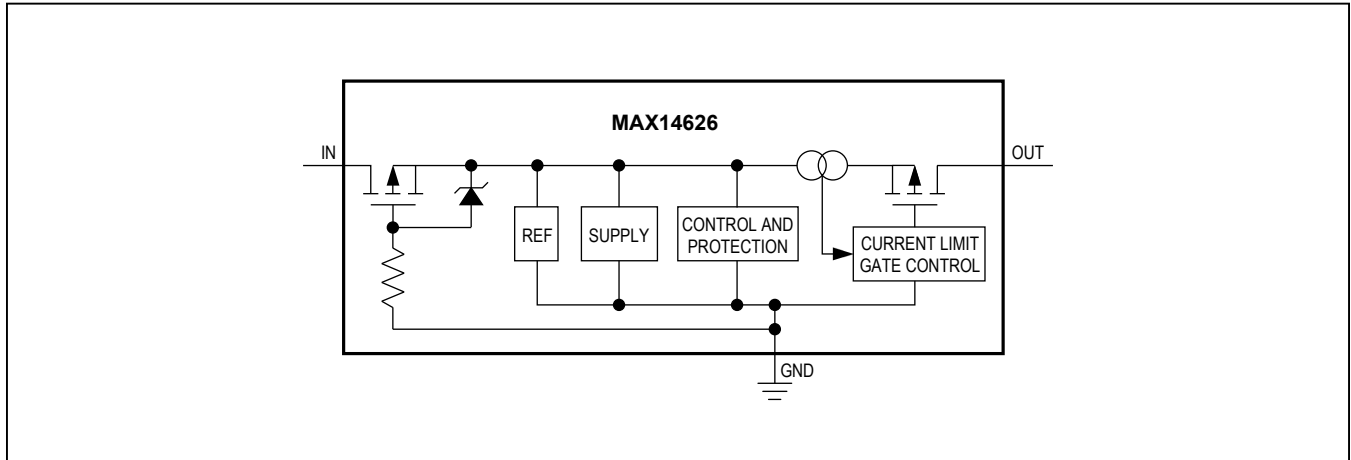

Detailed Description

The MAX14626 current loop protector features a current-limit switch to prevent damage to the sensor devices due to faulty current loop conditions. The current-limit switch features a 25Ω (typ) on-resistance and operates from a +2.3V to +36V input voltage range. The accurate current limit is set to 30mA, making the part ideal for protecting the sensor reading devices.

The MAX14626 handles an overcurrent event in a continuous current-limit mode. Additional safety features include thermal shutdown to prevent overheating and reverse input blocking to protect from being reverse connected into the sensor.

Reverse Input Protection

The device features reverse input protection to protect the downstream sensor. When a reverse input voltage is detected, control circuitry turns off the internal FET and isolates the output from the input.

Thermal Shutdown

The device enters thermal shutdown when the die temperature exceeds +150°C (typ). In thermal shutdown, the internal FETs are turned off. When the die temperature drops by 20°C, the device turns back on automatically.

Applications Information

Figure 1 shows the device in a 4–20mA current loop sensor application.

Exposed Pad and Layout Concerns

Connect the exposed pad to a large ground plane to maximize thermal performance. The exposed pad is not intended as an electrical connection point.

To optimize the switch response time to output short-circuit conditions, it is very important to keep all traces as short as possible to reduce the effect of undesirable parasitic inductance.

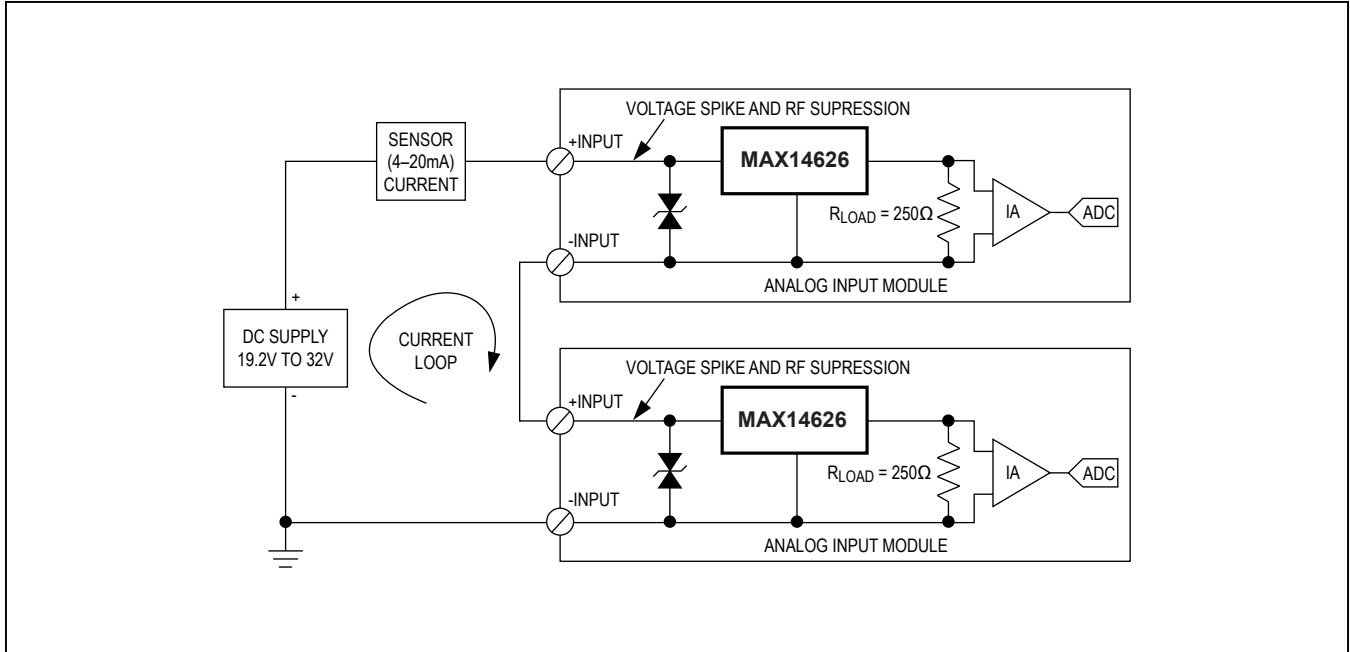

Figure 1. 4–20mA Current Loop Sensor Application

Ordering Information

PART	TEMP RANGE	PIN-PACKAGE	TOP MARK
MAX14626ETT+T	-40°C to +85°C	6 TDFN-EP*	AVF

+Denotes a lead(Pb)-free/RoHS-compliant package.

T = Tape and reel.

*EP = Exposed pad.

Package Information

For the latest package outline information and land patterns (footprints), go to www.maximintegrated.com/packages. Note that a “+”, “#”, or “-” in the package code indicates RoHS status only. Package drawings may show a different suffix character, but the drawing pertains to the package regardless of RoHS status.

PACKAGE TYPE	PACKAGE CODE	DOCUMENT NO.	LAND PATTERN
6 TDFN	T633+2	21-0137	90-0058

Chip Information

PROCESS: BiCMOS

Revision History

REVISION NUMBER	REVISION DATE	DESCRIPTION	PAGES CHANGED
0	3/12	Initial release	—
1	9/17	Updated TOC5 in <i>Typical Operating Characteristics</i>	4

For pricing, delivery, and ordering information, please contact Maxim Direct at 1-888-629-4642, or visit Maxim Integrated's website at www.maximintegrated.com.

Maxim Integrated cannot assume responsibility for use of any circuitry other than circuitry entirely embodied in a Maxim Integrated product. No circuit patent licenses are implied. Maxim Integrated reserves the right to change the circuitry and specifications without notice at any time. The parametric values (min and max limits) shown in the Electrical Characteristics table are guaranteed. Other parametric values quoted in this data sheet are provided for guidance.

Mouser Electronics

Authorized Distributor

Click to View Pricing, Inventory, Delivery & Lifecycle Information:

[Maxim Integrated:](#)

[MAX14626ETT+T](#)