

HENGSTLER



Encoders

- **Incremental**
- **Absolute**
- **Motor Feedback Systems**

Innovative products from your competent partner. Worldwide

HENGSTLER Products



Encoders

Absolute Encoders ACURO drive and ACURO industry, Incremental Encoders, Ex-proof and stainless steel versions, Bus Encoders.



Industrial Counting and Control Components

Starting from mini-counters up to ambitious control counters, multi-function counters, counters with interface, position indicators, timers, tachometers.



Printers and Cutters

Printer solutions e.g. applications in the sector of info points, ticket dispensers, cash dispensers, POS systems, modular thermal and needle printers, accessories such as winders and cutters.

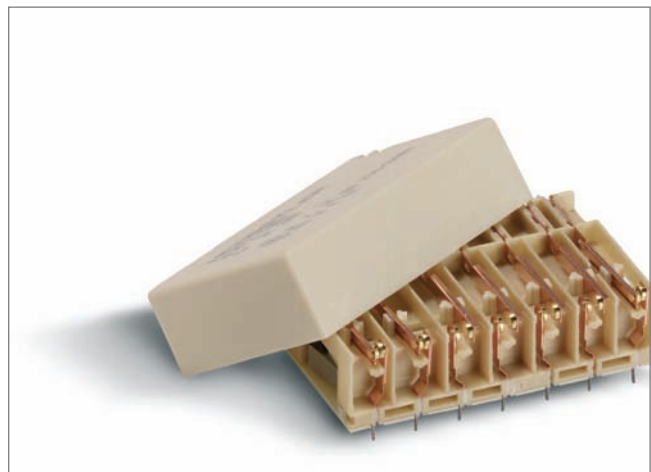

Relay technology

Main focus is the worldwide most versatile product range of safety relays – relays with guided contact sets. Furthermore: bistable relays, insulation relays, high-voltage relays, mini switching relays.

Further Danaher Brands of the Sensors & Controls Group

Dynapar™

Harowe™

Partlow™

Eagle Signal™

Namco™

Veeder-Root™

ENM™

NorthStar™

West™

Contents

Page

GENERAL ASPECTS

■ Variety and competence - HENGSTLER today	2
■ Our service for you	4
■ HENGSTLER produces worldwide	5

PRODUCTS

■ Products in this catalogue	7
■ Applications	34

INCREMENTAL ENCODERS

■ Overview of product range	38
■ Industrial encoder types with full shaft	47
■ Industrial encoder types with hollow shaft	62
■ Economy encoders	81
■ Encoder in explosion-proof versions and stainless steel versions	92
■ Sine-wave encoders	97

ABSOLUTE ENCODERS Single and Multiturn

■ Overview of product range	101
■ ACURO industry BiSS/ SSI Field bus systems Parallel	109
■ Encoder in explosion-proof versions and stainless steel versions	154

MOTOR FEEDBACK SYSTEMS

For Miniature DC & Stepper Motors

■ Overview of product range	167
■ Incremental kit encoders	180

For Asynchronous & DC Motors

■ Hollow shaft encoders	189
-------------------------	-----

For AC Synchronous & BLDC Motors

■ Comcoders	191
■ Incremental encoders	221
■ Absolute encoders	225
■ Sine-wave encoders	231
■ Resolvers	234

ACCESSORIES

■ Position indicator for absolute encoders	237
■ Encoder with shock module	240
■ Flexible couplings	241
■ Mounting elements	244
■ Connectors, cables	248
■ Measuring wheels	254

TECHNICAL BASICS

■ Encoders basics Output signals incremental encoders, maximum speed, protection class, examples of flange mounting	256
■ Basics of incremental encoders - output	261
■ Basics of sine-wave encoders	266
■ Basics of absolute encoders ACURO - interfaces	268
■ Glossary of technical terms	290

CONTACT

■ Sales and Service international	296
-----------------------------------	-----

OTHERS

■ Terms and Conditions	299
------------------------	-----

Good reasons for working with Hengstler

Better by competence.

This catalog provides proof of our competence in the business field of encoders – a comprehensive program characterized (as are all Hengstler products) by state-of-the-art technology, excellent design and highest standards of quality and reliability.

The Hengstler headquarters are located in Aldingen, in South-West Germany, on the edge of the Black Forest – a region famous for its industrial pioneers and inventors. The foundations for the Hengstler company were laid by one of these inventors, Johannes Hengstler, who, in 1846, set up a workshop which was later to become the center of the worldwide Hengstler group.

The workshop was started for the manufacture of clock springs; today, Hengstler products range from miniature counters to absolute hollow shaft encoders.



Hengstler – you can count on us.



The Hengstler headquarters in Aldingen.

All technical data and information contained herein, including the graphics, were collected and compiled with the utmost care.

This brochure provides information on products and accessories, which, however, does not constitute any guarantee for technical data or features. The user of these products must determine himself the suitability of the product for the intended use. All technical data is subject to alterations. For questions of technical nature or regarding prices and delivery, please contact our company headquarters or field service employees.

Successful with Hengstler



Innovation at an international level

Our numerous branches and representatives in Europe, America and Asia have made us a truly international enterprise. Our availability around the globe is, of course, a great benefit for our customers – the next Hengstler contact is never far away.

Our sound footing in all parts of the world also has a positive effect on our product know-how. Findings from worldwide research programs provide a pool of information from which, in turn, the material for the carefully directed, overall technological concept is won. These findings form the practice-oriented basis for ongoing innovation and efficiency in all corporate sectors.

The pace of innovation is getting faster and faster in all sectors of technology. Only those who are able to follow or even set this pace will continue to be competitive. Strong, reliable partners are needed to help you cope with these new demands. You need partners whose top priority is added product value/customer value, customer-orientation and high quality.

And taking all this into account, Hengstler is your partner of choice.

Hengstler is a leading European manufacturer in the field of industrial counting and control components, e.g. counters, encoders, industrial and temperature controllers, as well as relays. The product range is completed by printers and cutters, with Hengstler being the greatest manufacturer for cutters in Europe.

Hengstler: your Technology Partner

One of our particular strengths is the project management of custom applications. The basis for this is our wide experience gained over many years in the fields of electromechanics, mechanics, pneumatics and electronics which is, of course, mirrored in our product program. Hengstler offers its customers complete support starting at the project planning and development right through to the final product. At present we are handling complex projects in the field of pneumatics and printers for well-known companies, such as Bosch, Festo, IBM and Siemens.

Talk to Hengstler.
We can offer solutions.

Customer Orientation

- Hengstler is never far away – wherever you are in the world
- Application-specific assistance
- Customer-oriented manufacturing (one-piece-flow)
- Fair price/performance ratio
- Short delivery times and a high degree of availability
- 48-hour repair service

Experience

Hengstler was founded in 1846 and has been manufacturing counters since 1926, printers since 1970, sensors since 1987, relays since 1983...

Quality

- High-quality materials in accordance with VDE (Association of German Electrotechnical Engineers)
- UL, CL- and TÜV approvals
- DQS-certified to ISO 9001
- Environmental certified to DIN ISO 14001

Competence

- Vast know-how in the fields of development, manufacturing and sales marketing
- Assistance and support are provided by specialists.

Variety

- Hengstler offers a wide range of components for counting, controlling, indicating, measuring, switching and printing
- Get it all from one source!
- Benefit from numerous variants – for added flexibility.

Innovation

- Product development is based on state-of-the-art technology and highly advanced processes.
- Our products are setting the pace - around the globe
- We offer communicative products with state-of-the-art bus technology.

Our service for you



Customer Service

– always remains close to you – thanks to our extensive sales & distribution network. Please contact your local Hengstler distributor, addresses see chapter “Contact” (page 296).

Talk to Hengstler.
We offer solutions.

Customer Advantages:

- Personal customer service
- Many years of experience

World-wide Representation

You will always find a friendly contact at Hengstler – wherever you are in the world. Our experienced, competent partners are familiar with your branch – just get in touch. Please contact your local Hengstler distributor, addresses see chapter “Contact” (page 296).

Customer Advantages:

- We’re there for you – wherever you are – worldwide

Technical Support

If you should have any technical questions concerning your product selection or specific application – get fast and competent help. See chapter “Contact” (page 296).

Customer Advantages:

- Quick response to your technical queries

Always on the safe side

Quality and reliability of our products are our top priority. Our quality management system is DQS-certified to DIN EN ISO 9001. Reg. No. 1540-01.

Environmental responsibility

We are committed to environmentally responsible business practices and production. This is why our company has been certified to the DIN ISO 14001: 2004 environmental management systems standard.

Order Service

You can reach our team to place your order by phone between 8.00 am and 4.30 pm:

Phone +49 800-436 47 85 37 or
Phone +49 7424-89 201

Orders may also be placed 24 hours by
Fax +49 7424-89 500

Customer Advantages:

- No minimum order quantities or extra charge for small order sizes
- At any time reachable for your orders

Your order will be processed immediately after receipt. If any question remains regarding your order, we will call you back.

Please contact us if you require a quotation for higher quantities, special versions or delivery times. If you can’t find your desired product in our catalogue, don’t hesitate to let us know - we would be glad to help you.

Please visit as well our online store at www.hengstler.com

HENGSTLER produces worldwide

Germany – HENGSTLER GmbH
Aldingen

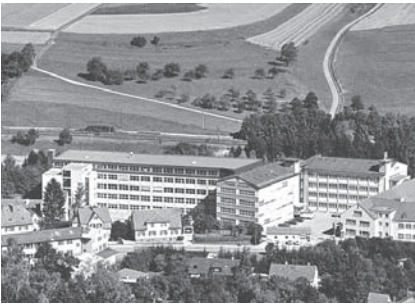

Slovakia – HENGSTLER sro
Kezmarok



USA – Danaher Controls
Gurnee, Illinois

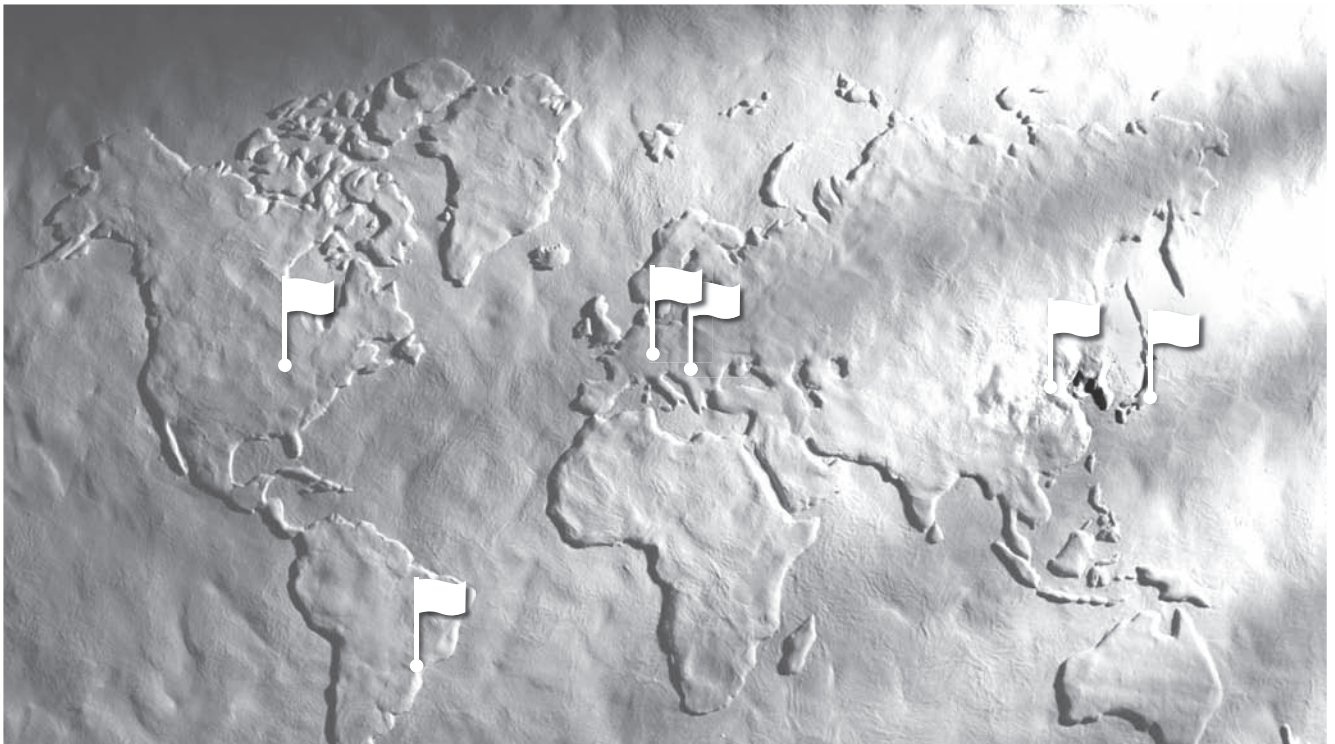

Brasil – Veeder Root do Brasil
Sao Paulo



China – Danaher ICG China
Tianjin



Japan – Danaher ICG Japan Co.
Osaka

Notes

Incremental Encoders - Industrial types

Solid shaft



Type	RI 30	RI 36	RI 58
Special features	<ul style="list-style-type: none"> ■ small encoder for industrial applications ■ low power consumption ■ high immunity to interference ■ cable lengths up to 100 m ■ suitable for high pulse frequencies ■ high level of protection ■ applications, e.g. CNC machine , handling systems, motors, medical technology, textile machinery 	<ul style="list-style-type: none"> ■ small industrial encoder for high numbers of pulses ■ high operating safety ■ applications, e.g. CNC axles, machine tools, robots, special machinery, high-speed winding machines 	<ul style="list-style-type: none"> ■ universal industrial encoder ■ up to 10 000 pulses ■ protection class up to IP67 ■ operating temperature up to 100°C ■ suitable for high shock loads ■ applications e.g. machine tools, CNC axles, packaging machinery, motors, drives, injection moulding machines, sawing machines, textile machinery
Number of pulses	5 ... 1500	5 ... 3600	1 ... 10000
Technical Data - mechanical			
Flange	S = synchro flange, R = pilot flange	S = synchro flange, R = pilot flange	S = synchro flange, K = pilot flange, Q = square flange, M = Synchro clamping flange
Shaft diameter	5 mm	6 / 6.35 mm	6 / 6.35 / 7 / 10 / 9.52 / 12 mm
Absolute max. shaft load radial/axial	10/5 N	10/5 N	Ø 12 mm - 80/60 N Ø 7 ... 10 mm - 60/40 N Ø 6 mm / 6.35 mm - 40/20 N
Absolute max. speed	10 000 min ⁻¹	10 000 min ⁻¹	10 000 min ⁻¹
Torque	≤ 0.2 Ncm	≤ 0.3 Ncm	≤ 0.5 Ncm
Protection class housing/bearing	IP64/64	IP64/64	IP65/64, IP67/67
General design	as per DIN VDE 0160, protection class III	as per DIN VDE 0160, protection class III	as per DIN VDE 0160, protection class III
Operating temperature	-10 ... +70 °C	-10 ... +70 °C	RI 58-O: -10 ... +70 °C/ RI 58-T: -25 ... +100 °C
Connection	Cable axial/radial	Cable or connector axial/radial	Cable or connector axial/radial
Size	Ø 30 mm	Ø 36 mm	Ø 58 mm, square fl.=63.5 mm/80mm
Weight approx.	60 g	80 g	300 g
Technical Data - electrical			
Output	RS 422 / push-pull	RS 422 / push-pull	RS 422 / push-pull / push-pull complementary
Supply voltage (SELV)	DC 5 V / DC 10 - 30 V	DC 5 V / DC 10 - 30 V	DC 5 V / DC 10 - 30 V
Max. current w/o load	40 mA (DC 5 V), 30 mA (DC 24 V), 60 mA (DC 10 V)	40 mA (DC 5 V), 30 mA (DC 24 V), 60 mA (DC 10 V)	40 mA (DC 5 V), 30 mA (DC 24 V), 60 mA (DC 10 V)
Max. pulse frequency	300 kHz (RS 422) 200 kHz (push-pull)	300 kHz (RS 422) 200 kHz (push-pull)	300 kHz (RS 422) 200 kHz (push-pull)
Output load	RS 422: ±30 mA push-pull with short circuit protection: 30 mA (DC 10 - 30 V)	RS 422: ±30 mA push-pull with short circuit protection: 30 mA (DC 10 - 30 V)	RS 422: ±30 mA push-pull with short circuit protection: 30 mA (DC 10 - 30 V)
Alarm output	NPN-O.C. 5 mA	NPN-O.C. 5 mA	NPN-O.C. 5 mA
Pulse shape	Square wave	Square wave	Square wave
Pulse duty factor	1 : 1	1 : 1	1 : 1
Page	47	51	54

Incremental Encoders - Industrial types

Hollow shaft



Type	RI 36-H	RI 58-H	RI 58-D
Special features	<ul style="list-style-type: none"> miniature industry encoder for high numbers of pulses short mounting depth easy mounting procedure applications, e.g. motors, machine tools, packaging machines, robots, automated SMD equipment 	<ul style="list-style-type: none"> through hollow shaft high accuracy due to integrated coupling secure shaft mounting applications e.g. textile machinery, motors, drives, copiers 	<ul style="list-style-type: none"> direct mounting without coupling flexible hollow shaft concept up to 14 mm through hollow shaft or as end shaft (blind shaft) operating temperature up to 100 °C (RI 58 TD) applications, e.g. positioning drives, motors
Number of pulses	5 ... 3600	1 ... 5000	1 ... 5000
Technical Data - mechanical			
Flange or shaft fixing	Clamping shaft (one side open) with front clamping ring; hubshaft with tether as torque support	S = synchro flange	E = synchro flange with blind shaft F, D, H= synchro flange with clamping shaft
Shaft diameter	Hollow shaft 4 / 6 / 8 / 10 mm	Hollow shaft 10 mm/12 mm	Hollow shaft 10 mm/12 mm/14 mm
Absolute max. shaft load	misalignment radial ± 0.15 mm, misalignment axial ± 0.5 mm,	misalignment axial ± 0.4 mm misalignment parallel 0,4 mm misalignment angular 1°	
Absolute max. speed	10000 min ⁻¹	3000 min ⁻¹	6000 min ⁻¹
Torque	≤ 0.3 Ncm	≤ 2 Ncm	≤ 1.7 Ncm
Protection class housing/bearing	IP64/64	IP64/64	IP65/64
General design	as per DIN VDE 0160, protection class III	as per DIN VDE 0160, protection class III	as per DIN VDE 0160, protection class III
Operating temperature	-10 ... +70 °C	-10 ... +70 °C	-10 ... +70 °C (Option: -25 .. +100 °C)
Connection	Cable axial/radial	Cable radial	Cable or connector radial
Size	Ø 36 mm	Ø 58 mm	Ø 58 mm
Weight approx.	80 g	210 g	170 g
Technical Data - electrical			
Output	RS 422/push-pull/ push-pull complementary	RS 422/push-pull/ push-pull complementary	RS 422/push-pull/ push-pull complementary
Supply voltage (SELV)	DC 5 V/DC 10 - 30 V	DC 5 V/DC 10 - 30 V	DC 5 V/DC 10 - 30 V
Max. current w/o load	40 mA (DC 5 V), 30 mA (DC 24 V), 60 mA (DC 10 V)	40 mA (DC 5 V), 30 mA (DC 24 V), 60 mA (DC 10 V)	40 mA (DC 5 V), 30 mA (DC 24 V), 60 mA (DC 10 V)
Max. pulse frequency	300 kHz (RS 422) 200 kHz (push-pull)	300 kHz (RS 422) 200 kHz (push-pull)	300 kHz (RS 422) 200 kHz (push-pull)
Output load	RS 422: ± 30 mA push-pull with short circuit protection: 30 mA (DC 10 - 30 V)	RS 422: ± 30 mA push-pull with short circuit protection: 30 mA (DC 10 - 30 V)	RS 422: ± 30 mA push-pull with short circuit protection: 30 mA (DC 10 - 30 V)
Alarm output	NPN-O.C. 5 mA	NPN-O.C. 5 mA	NPN-O.C. 5 mA
Pulse shape	Square wave	Square wave	Square wave
Pulse duty factor	1 : 1	1 : 1	1 : 1
Page	62	65	68

Incremental Encoders - Industrial types

Hollow shaft



Type	RI 76 TD	RI 80-E
Special features	<ul style="list-style-type: none"> ■ through hollow shaft ■ shaft diameters 15 to 42 mm ■ external diameter only 76 mm ■ simple installation with clamping ring front or rear ■ operating temperature up to 100 °C ■ applications e.g. motors, printing machines, elevators 	<ul style="list-style-type: none"> ■ Incremental Output ■ 30...45 mm hollow shaft ■ Rugged mechanical design ■ Unbreakable disc ■ Integrated diagnostic system ■ Wide voltage range DC 5 ... 30 V
Number of pulses	1 ... 10 000	1024, 2048, 4096 other number of pulses on request
Technical Data - mechanical		(preliminary)
Shaft fixation	Clamping ring front or rear	Keyway, set screw
Coupling	stator coupling (hubshaft with tether)	Spring tether (single, double)
Shaft diameter	Hollow shaft 15 ... 42 mm	
Max. speed	6 000 min ⁻¹ (depends on version)	3 600 min ⁻¹ (IP50), 1 500 min ⁻¹ (IP64)
Torque	3 ... 10 Ncm (depends on version)	
Protection class housing/bearing	IP50/40 (Option: IP65/64)	IP50, IP64
General design	as per DIN EN 61010, protection class III, Contamination level 2, over voltage class II	as per DIN EN 61010, protection class III, Contamination level 2, over voltage class II
Operating temperature	-25 ... +100 °C	-20 ... +70 °C
Connection	Cable radial	Sub-D 15p. / cable, radial
Size	Ø 76 mm	
Weight approx.	320 ... 580 g (depends on version)	1 000 g
Technical Data - electrical		(preliminary)
Output	RS 422 / push-pull / push-pull complementary	RS 422 / push-pull / push-pull complementary
Supply voltage (SELV)	DC 5 V / DC 10 - 30 V	DC 5 V ±10% or DC 5 - 30 V
Max. current w/o load	60 mA (DC 5 V), 60 mA (DC 10 V), 35 mA (DC 24 V)	60 mA (DC 5 V), 60 mA (DC 10 V), 35 mA (DC 24 V)
Max. pulse frequency	300 kHz (RS 422) 200 kHz (push-pull)	600 kHz (RS 422) 200 kHz (push-pull)
Output load	RS 422: ±30 mA push-pull with short circuit protection: 30 mA (DC 10 - 30 V)	RS 422: ±30 mA push-pull with short circuit protection: 40 mA (DC 5 - 30 V)
Alarm output	NPN-O.C. 5 mA	NPN-O.C. 5 mA
Pulse shape	Square wave	Square wave
Pulse duty factor	1 : 1	1 : 1
Page	74	78

Incremental Encoders - Economy types



Type	PC 9 / PC 9S
Special features	<ul style="list-style-type: none"> ■ Provides digital control inputs from operators' panel ■ Bidirectional squarewave signal outputs ■ Up to 512 increments ■ Continuous and reversible rotation ■ Noncontacting ■ Operating temperature -40 ... 100 °C
Number of pulses	100 ... 512
Technical Data - mechanical	
Absolute max. shaft load	1/8" Shaft: 4 N axial, 27 N radial 1/4" Shaft: 4 N axial, 4 N radial
Moment of inertia	0.20 gcm ²
Operating temperature	-40 ... +100 °C
Storage temperature	-50 ... +125 °C
Relative humidity	90 %, non-condensing
Connection	PC9: 10 pole header, (Accessory: 30 cm ribbon cable with connector) PC9S: 5 pole header, (Accessory: 30 cm cable with connector)
Technical Data - electrical	
Code	Inkremental, optical
Phasing	90° ±18° electrical
Symmetry	180° ±18° electrical
Index pulse width	90° ±36° electrical
Supply voltage	DC 5 V ±10 %
Supply current	10 mA, typical
Standby current	max. 50 µA (PC9 only)
Output signals	min. 2.5 V high (V _{OH}) max. 0.5 V low (V _{OL})
Output current	PC9: 3 mA sink/source (25 °C), 2 mA (100 °C) PC9S: 6 mA sink/source (25 °C), 4 mA (100 °C)
Max. pulse frequency	200 kHz
Pulse shape	Square wave
Pulse duty factor	1:1
Page	81

Incremental Encoders - Economy types



Type	RI 32	RI 38	RI 41
Special features	<ul style="list-style-type: none"> ■ economy encoder for small devices ■ long life due to ball bearings ■ low torque ■ application e.g. laboratory devices, fitness machines, crimping machines, tampon printing machines, small grinding machines 	<ul style="list-style-type: none"> ■ encoder for universal mounting due to front or rear fixing ■ long life due to ball bearings ■ low torque ■ applications e.g. small motors, laboratory devices, labelling devices, plotters, length measuring machines 	<ul style="list-style-type: none"> ■ economy encoder ■ high mechanical life ■ applications e.g. small motors, graphic machines, desktop robots, wood working machines
Number of pulses	5 ... 1500	5 ... 1024	5 ... 3600
Technical Data - mechanical			
Flange	R = pilot flange	Q = square flange	R = pilot flange
Shaft diameter	5 mm/6 mm	6 mm	6 mm
Absolute max. shaft load	radial 10 N, axial 5 N	radial 10 N, axial 5 N	radial 10 N, axial 5 N
Absolute max. speed	6 000 min ⁻¹	10 000 min ⁻¹	10 000 min ⁻¹
Torque	≤ 0.05 Ncm	≤ 0.2 Ncm	
Protection class housing/bearing	IP50/40	IP50/40	IP50/40
General design	as per DIN VDE 0160, protection class III	as per DIN VDE 0160, protection class III	as per DIN VDE 0160, protection class III
Operating temperature	-10° ... +60 °C	-10° ... +60 °C	-10° ... +70 °C
Connection	Cable radial/axial	Cable radial	Cable radial
Size	Ø 30 mm	39 x 39 mm	Ø 40 mm
Weight approx.	50 g	60 g	60 g
Technical Data - electrical			
Output	push-pull	push-pull	push-pull
Supply voltage (SELV)	DC 5 V or DC 10 - 30 V	DC 5 V or DC 10 - 30 V	DC 5 V or DC 10 - 30 V
Max. current w/o load	40 mA (DC 5 V), 30 mA (DC 24 V)	40 mA (DC 5 V), 30 mA (DC 24 V)	40 mA (DC 5 V), 30 mA (DC 24 V)
Max. pulse frequency	300 kHz (DC 5 V) 200 kHz (DC 10 - 30 V)	300 kHz (DC 5 V) 200 kHz (DC 10 - 30 V)	300 kHz (DC 5 V) 200 kHz (DC 10 - 30 V)
Output load	push-pull with short circuit protection: 10 mA (DC 5 V), 30 mA (DC 10 - 30 V)	push-pull with short circuit protection: 10 mA (DC 5 V), 30 mA (DC 10 - 30 V)	push-pull with short circuit protection: 10 mA (DC 5 V), 30 mA (DC 10 - 30 V)
Alarm output	NPN-O.C. 5 mA	NPN-O.C. 5 mA	NPN-O.C. 5 mA
Pulse shape	Square wave	Square wave	Square wave
Pulse duty factor	1 : 1	1 : 1	1 : 1
Page	84	86	88

Incremental Encoders - Economy types



Type	RI 42
Special features	<ul style="list-style-type: none"> ■ economy encoder ■ high protection IP65 ■ push-pull or NPN-O.C. ■ applications, e.g. textile machinery
Number of pulses	5 ... 1 024
Technical Data - mechanical	
Flange	R = pilot flange
Shaft diameter	6 mm
Absolute max. shaft load	radial 10 N, axial 5 N
Absolute max. speed	10 000 min ⁻¹
Torque	≤ 1 Ncm
Protection class housing/bearing	IP65/64
General design	as per DIN VDE 0160, protection class III
Operating temperature	0° ... +60 °C
Connection	Cable axial
Size	Ø 40 mm
Weight approx.	75 g
Technical Data - electrical	
Output	push-pull / push-pull complementary / NPN-O.C.
Supply voltage (SELV)	DC 5 V / DC 10 - 30 V / DC 10 - 24 V
Max. current w/o load	40 mA (DC 5 V), 30 mA (DC 24 V)
Max. pulse frequency	300 kHz (DC 5 V) 200 kHz (DC 10 - 30 V) 50 kHz (DC 10 - 24 V)
Output load	push-pull with short circuit protection: 10 mA (DC 5 V), 30 mA (DC 10 - 30 V)
Alarm output	NPN-O.C. 5 mA
Pulse shape	Square wave
Pulse duty factor	1 : 1
Page	90

Incremental EX and Stainless Steel Encoders



Type	RX 70-TI / RX 71-TI (Stainless)	RI 59
Special features	<ul style="list-style-type: none"> ■ explosion-proof according to EX II 2 G/D EEX d IIC T6/T4 ■ highest operating safety ■ applications e.g. lacquering lines, surface processing machines, filling plants, mixing machines, silo systems 	<ul style="list-style-type: none"> ■ stainless steel encoder with high degree of protection ■ high corrosion resistance ■ suitable for use in food production ■ applications e.g. packaging machinery, filling plants, washing systems, mixing machines
Number of pulses	1 ... 10 000	1 ... 10 000
Technical Data - mechanical		
Flange	K = clamping flange	Q = square flange
Shaft diameter	10 mm	9.52 mm / 10 mm
Max. shaft load	radial 100 N, axial 40 N	radial 60 N, axial 40 N
Max. speed	6 000 min ⁻¹ (T6), 10 000 min ⁻¹ (T4)	10 000 min ⁻¹
Torque	≤ 0.5 Ncm	≤ 0.5 Ncm
Protection class housing/bearing	IP65/64	IP67/67
General design	as per DIN VDE 0160, protection class III	as per DIN VDE 0160, protection class III
Operating temperature	-10 ... + 40 °C	-10 ... + 70 °C
Connection	Cable axial	Cable radial
Size	Ø 70 mm	Ø 58 mm, square flange = 63.5 mm
Weight approx.	1400 g	620 g
Technical Data - electrical		
Output	RS 422 / push-pull / push-pull complementary	RS 422 / push-pull / push-pull complementary
Supply voltage (SELV)	DC 5 V / DC 10 - 30 V	DC 5 V / DC 10 - 30 V
Max. current w/o load	40 mA (DC 5 V), 30 mA (DC 24 V), 60 mA (DC 10 V)	40 mA (DC 5 V), 30 mA (DC 24 V), 60 mA (DC 10 V)
Max. pulse frequency	300 kHz (RS 422) 200 kHz (push-pull)	300 kHz (RS 422) 200 kHz (push-pull)
Output load	RS 422: ±30 mA push-pull with short circuit protection: 30 mA (DC 10 - 30 V)	RS 422: ±30 mA push-pull with short circuit protection: 30 mA (DC 10 - 30 V)
Alarm output	NPN-O.C. 5 mA	NPN-O.C. 5 mA
Pulse shape	Square wave	Square wave
Pulse duty factor	1 : 1	1 : 1
Pulse width error	± max. 25° electrical	± max. 25° electrical
Page	92	95

Incremental Sine-Wave Encoders



Type	RIS 58-0	RIS 58-H
Special features	<ul style="list-style-type: none"> ■ Harmonic distortion less than 1 % ■ Extended temperature range, -40° up to +100 °C ■ 500 kHz sine-wave incremental signal frequency response ■ Self-monitoring and error compensation ■ Secure against short-circuit and overload 	<ul style="list-style-type: none"> ■ Harmonic distortion less than 1 % ■ Extended temperature range, -40° up to +100 °C ■ 500 kHz sine-wave incremental signal frequency response ■ Self-monitoring and error compensation ■ Secure against short-circuit and overload
Number of pulses	1 000, 1 024, 2 048, 2 500 (other number of pulses on request)	1 000, 1 024, 2 048(other number of pulses on request)
Technical Data - mechanical		
Shaft diameter	6 mm	10 mm, 12 mm hollow shaft
Absolute max. shaft load	radial 60 N/ axial 40 N	
Balance tolerances		axial ±1.5 mm, radial ±0.2 mm
Max. speed	12 000 min ⁻¹	12 000 min ⁻¹
Torque	≤ 1 Ncm	≤ 1 Ncm
Protection (EN 60529)	Bearing IP64, Housing IP65	Bearing IP64, Housing IP65
General design	as per DIN EN 61010-1	as per DIN EN 61010-1
Operating temperature	-40 ... +100 °C	-40 ... +100 °C
Vibration (IEC 68-2-6)	≤ 100 m/s ²	≤ 100 m/s ²
Shock (IEC 68-2-27)	≤ 1 000 m/s ²	≤ 1 000 m/s ²
Material housing	Aluminium	Aluminium
Connection	Cable axial or radial Conin axial or radial	Cable axial or radial Conin axial or radial
Size	Ø 58 mm	Ø 58 mm
Weight approx.	265 g	270 g
Technical Data - electrical		
Supply voltage (SELV)	DC 5 V / ±10 %	DC 5 V / ±10 %
Max. current w/o load	120 mA	120 mA
Incremental signals A, B	Sine - Cosine 1 Vpp	Sine - Cosine 1 Vpp
Absolute accuracy	±35"	±35"
Repeatability	±7"	±7"
Max. frequency	500 kHz	500 kHz
Reference signal: R	> 0,4 V (1 pulse / turn)	> 0,4 V (1 pulse / turn)
Page	97	99

Absolute Shaft Encoders - ACURO industry

AC 36 - BiSS / SSI

Special Features

- Compact design for single or multiturn
- Interfaces: standard SSI, expanded SSI mode or BiSS
- Use of sine / cosine signals for fast control tasks possible



Type	AC36 - BiSS / SSI
Technical Data - mechanical	(preliminary)
Housing diameter	37.5 mm
Protection class shaft input	IP64
Protection class housing	IP64
Flange	pilot flange
Shaft diameter	6 mm
Max. speed	Continuous: 10 000 min ⁻¹ , Short term: 12 000 min ⁻¹
Starting Torque	0,01 Nm
Moment of inertia	2.5 x 10 ⁻⁶ kgm ²
Spring tether (hollow shaft)	
Tolerance axial / radial	± 0.5 mm/ ± 0.05 mm
Shock resistance DIN EN 60068-2-27	1 000 m/s ² (6 ms)
Vibration resistance DIN EN 60068-2-6	100 m/s ² (10 ... 2 000 Hz)
Operating temperature	-25 ... +100 °C
Storage temperature	-15 ... +85 °C (because of packing)
Weight approx. ST/MT	80 g / 130 g
Technical Data - electrical	(preliminary)
Supply voltage	DC 5 V, -5 % / + 10 %
Max. current w/o load ST/MT	50 mA / 100 mA
Interface	BiSS or Standard SSI
Lines / Drives	Clock and Data / RS422
Output code	Gray or Binary
Resolution singleturn	13 Bit ... max. 17 Bit
Resolution multiturn	12 Bit
Incremental signals	Sine - Cosine 1 Vpp
Number of pulses	2048
3 dB limiting frequency	500 kHz
Alarm output	Alarm bit (SSI option), warning bit and alarm bit (BiSS)
Connection	Cable axial or radial
Page	109

Absolute Shaft Encoders - ACURO industry

AC 58 - BiSS / SSI, Parallel

Special Features

- Compact design for single or multiturn
- Aids for start-up and operation: diagnostic LED, preset key with optical response
- Interfaces: standard SSI, expanded SSI mode or BiSS
- Use of sine / cosine signals for fast control tasks possible



Type	AC 58 - BiSS / SSI	AC 58 - Parallel
Technical Data - mechanical		
Housing diameter	58 mm	58 mm
Protection class shaft input	IP64 or IP67	IP64 or IP67
Protection class housing	IP64 (IP67 optional)	IP64 (IP67 optional)
Flange	Synchro flange, clamping flange, hubshaft with tether, square flange	Synchro flange, clamping flange, hubshaft with tether, square flange
Shaft diameter	Solid shaft 6 mm, 10 mm; Hub shaft 10 mm, 12 mm	Solid shaft 6 mm, 10 mm; Hub shaft 10 mm, 12 mm
Max. speed	Continuous: 10 000 min ⁻¹ , Short term: 12 000 min ⁻¹	Continuous: 10 000 min ⁻¹ , Short term: 12 000 min ⁻¹
Shaft load	axial 40 N / radial 60 N	axial 40 N / radial 60 N
Operating temperature	-40 ... 100 °C	-40 ... 100 °C
Weight approx. ST/MT	260 g / 310 g	350 g / 400 g
Technical Data - electrical		
Supply voltage	DC 5 V, -5 % / + 10 % or DC 10 - 30 V	DC 10 - 30 V
Max. current w/o load ST/MT	50 mA / 100 mA	200 mA / 300 mA
Interface	BiSS or Standard SSI	Parallel
Resolution singleturn	10-17 Bit, Gray Excess: 360, 720 steps	10-14 Bit, Gray Excess: 360, 720 steps
Resolution multi turn	12 Bit	12 Bit
Optional incremental signals	Sine - Cosine 1 Vpp	
Number of pulses	2048	
Absolute accuracy	±35"	
Repeat accuracy	±7"	
Parameterization	Code type, direction of rotation, warning, alarm	
Control input	Direction	ST: Latch, Direction, Tristate MT: Tristate
Reset key	Latch via parameterization	only with MT
Alarm output	Alarm bit (SSI option), warning bit and alarm bit (BiSS)	NPN o.c. max. 5 mA
Status LED	Green = OK.; red = alarm	Green = OK.; red = alarm
Connection	Cable axial or radial Conin axial or radial M12, 8 pole	Cable axial or radial 17 pole Conin axial or radial 37 pole Sub-D
Page	113	118

Absolute Shaft Encoders - ACURO industry

AC 58 with Fieldbus Interfaces

Special Features

- Overall length: 63 mm for singleturn, 73 mm for multiturn, including bus cover
- The complete bus specific electronics is integrated in the connection cover
- Option: Display "tico"
- Diagnostic LEDs in the bus cover



Type	AC 58 - Profibus	AC 58 - CANopen	AC 58 - CANLayer 2
Technical Data - mechanical			
Housing diameter	58 mm	58 mm	58 mm
Protection class shaft input	IP64 or IP67	IP64 or IP67	IP64 or IP67
Protection class housing	IP67	Bus cover: IP67 Conin, cable: IP64 (IP67 optional)	Bus cover: IP67 Conin, cable: IP64 (IP67 optional)
Flange	Synchro flange, clamping flange, hubshaft with tether, square flange	Synchro flange, clamping flange, hubshaft with tether, square flange	Synchro flange, clamping flange, hubshaft with tether, square flange
Shaft diameter	Solid shaft 6 mm, 10 mm; Hub shaft 10 mm, 12 mm	Solid shaft 6 mm, 10 mm; Hub shaft 10 mm, 12 mm	Solid shaft 6 mm, 10 mm; Hub shaft 10 mm, 12 mm
Max. speed	Continuous: 10 000 min ⁻¹ , Short term: 12 000 min ⁻¹	Continuous: 10 000 min ⁻¹ , Short term: 12 000 min ⁻¹	Continuous: 10 000 min ⁻¹ , Short term: 12 000 min ⁻¹
Shaft load	axial 40 N / radial 60 N	axial 40 N / radial 60 N	axial 40 N / radial 60 N
Operating temperature	-40 ... 85 °C	-40 ... 85 °C	-40 ... 85 °C
Weight approx. ST/MT	350 g / 400 g	350 g / 400 g	350 g / 400 g
Technical Data - electrical			
Supply voltage	DC 10 - 30 V	DC 10 - 30 V	DC 10 - 30 V
Max. current w/o load ST/MT	220 mA / 250 mA	220 mA / 250 mA	220 mA / 250 mA
Interface	RS 485	CAN High-Speed according ISO/DIS 11898	CAN High-Speed according ISO/DIS 11898
Profile / Protocol	Profibus DP with encoder profile Class C2 (parameterizable)	CANopen accord. DS 301 with encoder profile DSP 406	CAN 2.0 A
Programmable	Resolution, preset, direction	Resolution, preset, direction	Direction, limit values
Output code	Binary	Binary	Binary
Transfer mode		Poll mode (only on request), Change of State (automatic if value changes), cyclical with adjustable cycle timer	Poll mode (only on request), Change of State (automatic if value changes), cyclical with adjustable cycle timer
Baud rate	is automatically set within a range of 9,6 Kbaud through 12 Mbaud	set via DIP switch within a range of 10 trough 1000 Kbit/s	set via DIP switch within a range of 10 trough 1000 Kbit/s
Resolution singleturn	10-14 Bit	10-14 Bit	10-14 Bit
Resolution multiturn	12 Bit	12 Bit	12 Bit
Integrated special functions	speed, acceleration, operating time	speed, acceleration, round axis, limit values	
Connection	Bus cover with: <ul style="list-style-type: none"> • 3 M12 connectors • 3 sealed cable exits • double conin 12 pole radial cw • 4 pole M12 f. "tico" display + 2 sealed cable exits 	Bus cover with: <ul style="list-style-type: none"> • 3 sealed cable exits • double conin 9 pole radial cw Cable radial or axial Conin radial or axial, cw or ccw	Bus cover with: <ul style="list-style-type: none"> • 3 sealed cable exits • double conin connectors 9 pole radial cw Cable radial or axial Conin radial or axial, cw or ccw
Page	123	127	130

Absolute Shaft Encoders - ACURO industry

AC 58 with Fieldbus Interfaces

Special Features

- Overall length: 63 mm for singleturn, 73 mm for multiturn, including bus cover
- The complete bus specific electronics is integrated in the connection cover
- Option: Display "tico"
- DiagnosticLEDs in the bus cover



Type	AC 58 - DeviceNet	AC 58 - Interbus	AC 58 - SUCOnet
Technical Data - mechanical			
Housing diameter	58 mm	58 mm	58 mm
Protection class shaft input	IP64 or IP67	IP64 or IP67	IP64 or IP67
Protection class housing	IP67	Bus cover: IP67 Cable: IP64 (IP67 optional)	IP64
Flange	Synchro flange, clamping flange, hubshaft with tether, square flange	Synchro flange, clamping flange, hubshaft with tether, square flange	Synchro flange, clamping flange, hubshaft with tether, square flange
Shaft diameter	Solid shaft 6 mm, 10 mm; Hub shaft 10 mm, 12 mm	Solid shaft 6 mm, 10 mm; Hub shaft 10 mm, 12 mm	Solid shaft 6 mm, 10 mm; Hub shaft 10 mm, 12 mm
Max. speed	Continuous: 10 000 min ⁻¹ , Short term: 12 000 min ⁻¹	Continuous: 10 000 min ⁻¹ , Short term: 12 000 min ⁻¹	Continuous: 10 000 min ⁻¹ , Short term: 12 000 min ⁻¹
Shaft load	axial 40 N / radial 60 N	axial 40 N / radial 60 N	axial 40 N / radial 60 N
Operating temperature	-40 ... 85 °C	-40 ... 70 °C	-10 ... 60 °C
Weight approx. ST/MT	350 g / 400 g	350 g / 400 g	260 g / 310 g
Technical Data - electrical			
Supply voltage	DC 10 - 30 V	DC 10-30 V	DC 10-30 V
Max. current w/o load ST/MT	220 mA / 250 mA	220 mA / 250 mA	220 mA
Interface	CAN High-Speed according ISO/DIS 11898, CAN-Specification 2.0 A (11-Bit-Identifier)	Remote installation bus Interbus, ENCOM Profile K3 (parameterizable), K2	RS485
Profile / Protocol	DeviceNet nach Rev. 2.0, programmable encoder	K3 = ID-Code 37 K2 = ID-Code 36	SUCOnet-K1 or Hengstler-G1-Protocol
Programmable	Resolution, preset, direction	Direction, scaling factor, preset, offset	
Output code	Binary	32 Bit binary	Binary
Transfer mode	Poll mode (only on request), Change of State (automatic if value changes), cyclical with adjustable cycle timer		
Baud rate	set via DIP switches to 125, 250, 500 Kbaud	500 Kbaud according ENCOM	
Resolution singleturn	10-14 Bit	10-12 Bit	10 - 13 Bit
Resolution multiturn	12 Bit	12 Bit	12 Bit
Connection	Bus cover with: <ul style="list-style-type: none"> • 2 sealed cable exits • 4 pole M12 f. "tico" display + 2 sealed cable exits • 5 pole M12 	Bus cover with: <ul style="list-style-type: none"> • 3 sealed cable exits • 4 pole M12 f. "tico" Display + 2 sealed cable exits • double conin 9 pole Cable 12 pole, radial and axial 	Cable axial/ radial
Page	133	136	140

Absolute Shaft Encoders - ACURO industry

AC 58 - SSI programmable

Special Features

- Compact design: 59mm length for single or multiturn
- Aids for start-up and operation: diagnostic LED, preset key with optical response
- Parameterization: resolution, code type, sense of rotation, output format, warning, alarm
- Parameters can be stored in a non-volatile memory



Type	AC 58 - SSI Programmable
Technical Data - mechanical	
Housing diameter	58 mm
Protection class shaft input	IP64 or IP67
Protection class housing	IP64 (IP67 optional)
Flange	Synchro flange, clamping flange, hubshaft with tether, square flange
Shaft diameter	Solid shaft 6 mm, 10 mm; Hub shaft 10 mm, 12 mm
Max. speed	Continuous: 10 000 min ⁻¹ , Short term: 12 000 min ⁻¹
Shaft load	axial 40 N / radial 60 N
Operating temperature	-40 ... 70 °C
Weight approx. ST/MT	260 g / 310 g
Technical Data - electrical	
Supply voltage	DC 10 - 30 V
Max. current w/o load	max. 250 mA
Interface	SSI programmable
Resolution singleturn	10 - 17 Bit
Resolution multiturn	12 Bit
Parameterization	resolution, code type, sense of rotation, output format, warning, alarm
Control input	Direction, Preset 1, Preset 2
Alarm output	Alarm bit
Status LED	Green = ok.; red = alarm
Connection	Cable radial or axial Conin radial or axial, ccw
Page	142

Absolute Shaft Encoders - ACURO industry

AC 110 - BiSS / SSI

Special Features

- Hollow shaft up to 50 mm
- Singleturn up to bis 17 Bit



Type	AC 110 - BiSS / SSI
Technical Data - mechanical	(preliminary)
Housing diameter	110 mm
Shaft diameter	up to 50 mm
Protection class shaft	IP50 or IP64
Protection class housing	IP50 or IP64
Flange	Hollowshaft with tether
Max. speed	IP50: 3600 min ⁻¹ IP64: 1500 min ⁻¹
Spring tether (hollow shaft) Tolerance axial / radial	± 0.5 mm / ± 0.05 mm
Vibration resistance (IEC 68-2-6)	100 m/ s ² (10 - 500 Hz)
Shock resistance (IEC 68-2-27)	1000 m/ s ² (6 ms)
Operating temperature	-20 ...+70°C
Storage temperature	-50 ...+80°C
Weight approx.	1000 g
Technical Data - electrical	(preliminary)
Supply voltage	DC 5 V (-5 %/ +10 %) or DC 10-30 V
Max. current w/o load ST/MT	120 mA
Lines/ Drives	Clock and Data/ RS422
Output code	Binary or Gray
Resolution singleturn	10 - 17 Bit
Incremental signals	Sine - Cosine 1 Vpp
No. of increments	4096
3 dB limiting frequency	500 kHz
Absolute accuracy	± 35"
Repeatability	± 7"
Alarm output	alarm bit (SSI), warning bit and alarm bit (BiSS)
Connection	Cable radial Cable with Conin-Coupling
Page	151

Absolute Shaft Encoders

Stainless Steel / Explosion-Proof



Type	AC 59/61	AX 70/ AX 71 (Stainless)
Special Features	<ul style="list-style-type: none"> ■ Compact design ■ Protection class IP67 ■ High corrosion resistance ■ Robust design ■ Resolution up to 29 Bit (17 Bit ST, 12 Bit MT) ■ Connection with cable or with bus terminal box ■ Applications: <ul style="list-style-type: none"> - Packaging machine for food and beverage - Ship equipment (e.g. cranes, winches, cable laying ships) - Offshore - Applications 	<ul style="list-style-type: none"> ■ ATEX certification for gas and dust explosion proof ■ EX-classification: Ex II 2 G/D E Ex d II C T4/T6 ■ Same electrical performance as ACURO industry ■ Protection class up to IP67 ■ Diameter only 70 mm ■ Robust design ■ Available with stainless steel ■ Resolution up to 29 Bit (17 Bit ST, 12 Bit MT) ■ Applications: enamelling production line, petro chemistry, bottling machines, mixers, silo works, mills ■ Interfaces: SSI, SSI programmable, Profibus, CANopen
Technical Data – mechanical		
Housing diameter		70 mm
Shaft diameter	10 mm	10 mm
Flange	Square flange 63.5 x 63.5 mm	Clamping flange
Max. speed	Short term: 10 000 min ⁻¹ Continuous: 6 000 min ⁻¹	6 000 min ⁻¹ (T6) 10 000 min ⁻¹ (T4)
Torque	< 1 Ncm	≤ 1 Ncm
Moment or inertia	approx. 20 gcm ²	approx. 20 gcm ²
Max. shaft load	axial 40 N/ radial 60 N	axial 40 N/ radial 100 N
Vibration proof (IEC 68-2-6)	100 m/ s ² (10 - 500 Hz)	100 m/ s ² (10 - 500 Hz)
Shock resistance (IEC 68-2-27)	1000 m/ s ² (6 ms)	1000 m/ s ² (6 ms)
Operating temperature	SSI, BiSS, Parallel: -40...+100°C SSI-P, Interbus: -40...+70°C Profibus, CANopen, CANlayer2, DeviceNet: -40...+ 85°C	-40 ... +60 °C (T4) -40 ... +40 °C (T6)
Storage temperature	40...+ 85°C	-25 ... +80 °C
Material Shaft/ Housing	Stainless steel	Aluminium (AX 70) Stainless steel (AX 71)
Weight approx.	AC 59 with 1.5 m cable: 700 g AC 61 with 1.5 m cable: 980 g AC 61 with bus cover (MT): 1 180 g	1 000 g (AX 70), 1 900 g (AX 71)
Technical Data – electrical		
	The electrical data depend on the type of interface. Please refer to the specific interface chapter.	The electrical data depend on the type of interface. Please refer to chapter "AX 70 / AX 71".
Page	154	161

Motor Feedback Systems - Kit Encoders for Miniature DC and Stepper Motors



Type	E 9	M 9	M 14
Special features	<ul style="list-style-type: none"> ■ ideal for position and speed sensing in small machines and actuators ■ low power standby mode is ideal for battery powered devices ■ 200 kHz operating frequency ■ resolution to 512 lines/rev 	<ul style="list-style-type: none"> ■ ideal for position and speed sensing in small machines and actuators ■ 200 kHz operating frequency ■ resolution to 512 lines/rev 	<ul style="list-style-type: none"> ■ ideal economical feedback device for servo and stepper motors ■ short axial length and compact 1.5 inch diameter ■ easy "snap-on" installation ■ high resolution to 1024 lines/rev and 200 kHz bandwidth ■ drop-in replacement for HP 5540
Number of pulses	100 ... 512	100 ... 512	200 ... 1 024
Commutation	None	None	None
Technical Data - mechanical			
Shaft diameter	Hollow shaft Ø 1.5 ... 4.0 mm	Hollow shaft Ø 1.5 ... 4.0 mm	Hollow shaft Ø 3.0 ... 8.0 mm
Max. speed	12 000 min ⁻¹	12 000 min ⁻¹	12 000 min ⁻¹
Protection class housing/bearing	---	---	---
Operating temperature	-40 ... + 100 °C	-40 ... + 100 °C	-40 ... + 100 °C
Diameter	22.0 mm	22.0 mm	38.0 mm
Mounting depth	20.0 mm	14.8 mm	17.2 mm
Technical Data - electrical			
Output	TTL	TTL	TTL
Supply voltage (SELV)	DC 5 V ±10 %	DC 5 V ±10 %	DC 5 V ±10 %
Max. current w/o load	10 mA, typ. Standby current: max. 50 µA	10 mA, typ.	10 mA, typ.
Max. pulse frequency	200 kHz	200 kHz	200 kHz
Max. output load	3 mA (25°C), 2 mA (100°C)	3 mA (25°C), 2 mA (100°C)	6mA (25°C) 4 mA (100°C)
Pulse shape	Square wave	Square wave	Square wave
Phasing	90°±18° electrical	90°±18° electrical	90°±18° electrical
Symmetry	180°±18° electrical	180°±18° electrical	180°±18° electrical
Page	180	183	186

Motor Feedback Systems - Hollow shaft Encoders for Asynchronous & DC Motors



Type	RI 36-H	RI 58-D	RI 58TD
Special features	<ul style="list-style-type: none"> ■ miniature industry encoder for high numbers of pulses ■ short mounting depth ■ easy mounting procedure ■ applications, e.g. motors, machine tools, packaging machines, robots, automated SMD equipment 	<ul style="list-style-type: none"> ■ direct mounting without coupling ■ flexible hollow shaft concept up to 14 mm ■ through hollow shaft or as end shaft (blind shaft) ■ easy mounting procedure with clamping flange or fastening thread ■ short mounting depth of 33 mm ■ operating temperature up to 80 °C ■ Fixing of the flange with a stator coupling or cylindrical pin ■ applications, e.g. positioning drives, motors 	<ul style="list-style-type: none"> ■ direct mounting without coupling ■ flexible hollow shaft concept up to 14 mm ■ through hollow shaft or as end shaft (blind shaft) ■ easy mounting procedure with clamping flange or fastening thread ■ short mounting depth of 33 mm ■ operating temperature up to 100 °C ■ Fixing of the flange with a stator coupling or cylindrical pin ■ applications, e.g. positioning drives, motors
Number of pulses	5 ... 3 600	1 ... 5 000	4 ... 2 500
Commutation	None	None	None
Technical Data - mechanical			
Shaft diameter	Hollow shaft 4 / 6 / 8 / 10 mm	Hollow shaft 10 mm / 12 mm / 14 mm	Hollow shaft 10 mm / 12 mm / 14 mm
Max. speed	10 000 min ⁻¹	6 000 min ⁻¹	6 000 min ⁻¹
Max. speed (continuous)			
Protection class housing/bearing	IP64/64	IP65/64	IP65/64
General design	as per DIN VDE 0160, protection class III	as per DIN VDE 0160, protection class III	as per DIN VDE 0160, protection class III
Operating temperature	-10 ... +70 °C	-10 ... +70 °C	-25 .. +100 °C
Diameter	36 mm	58 mm	58 mm
Mounting depth	39 mm	33 mm .. 50.5 mm (depends on version)	33 mm .. 50.5 mm (depends on version)
Technical Data - electrical			
Output	RS 422 / push-pull / push-pull complementary	RS 422 / push-pull / push-pull complementary	RS 422 / push-pull / push-pull complementary
Supply voltage (SELV)	DC 5 V / DC 10 - 30 V	DC 5 V / DC 10 - 30 V	DC 5 V / DC 10 - 30 V
Max. current w/o load	40 mA (DC 5 V), 30 mA (DC 24 V), 60 mA (DC 10 V)	40 mA (DC 5 V), 30 mA (DC 24 V), 60 mA (DC 10 V)	40 mA (DC 5 V), 30 mA (DC 24 V), 60 mA (DC 10 V)
Max. pulse frequency	300 kHz (RS 422) 200 kHz (push-pull)	300 kHz (RS 422) 200 kHz (push-pull)	300 kHz (RS 422) 200 kHz (push-pull)
Max. output load	RS 422: ±30 mA push-pull with short circuit protection: 30 mA (DC 10 - 30 V)	RS 422: ±30 mA push-pull with short circuit protection: 30 mA (DC 10 - 30 V)	RS 422: ±30 mA push-pull with short circuit protection: 30 mA (DC 10 - 30 V)
Pulse shape	Square wave	Square wave	Square wave
Page	62	68	68

Motor Feedback Systems - Hollow shaft Encoders for Asynchronous & DC Motors



Type	RI 76TD	RI 80-E
Special features	<ul style="list-style-type: none"> ■ through hollow shaft ■ shaft diameters 15 to 42 mm ■ external diameter only 76 mm ■ simple installation with clamping ring front or rear ■ operating temperature up to 100 °C ■ applications e.g. motors, printing machines, elevators 	<ul style="list-style-type: none"> ■ incremental Output ■ 30...45 mm hollow shaft ■ rugged mechanical design ■ unbreakable disc ■ integrated diagnostic system ■ wide voltage range DC 5 ... 30 V
Number of pulses	1 ... 10 000	1024, 2048, 4096 other number of pulses on request
Commutation	None	None
Technical Data - mechanical		
Shaft fixation	Clamping ring front or rear	Keyway, set screw
Coupling	stator coupling (hubshaft with tether)	Spring tether (single, double)
Shaft diameter	Hollow shaft 15 ... 42 mm	Hollow shaft 30 ... 45 mm
Max. speed	6 000 min ⁻¹ (depends on version)	3 600 min ⁻¹ (IP50), 1 500 min ⁻¹ (IP64)
Protection class housing/bearing	IP50/40 (Option: IP65/64)	IP50, IP64
General design	as per DIN EN 61010, protection class III, Contamination level 2, over voltage class II	as per DIN EN 61010, protection class III, Contamination level 2, over voltage class II
Operating temperature	-25 ... +100 °C	-20 ... +70 °C
Connection	Cable radial	Sub-D 15p. / cable, radial
Diameter	76 mm	
Weight	320 ... 580 g (depends on version)	1 000 g
Technical Data - electrical		
Output	RS 422/push-pull/push-pull complementary	RS 422/push-pull/push-pull complementary
Supply voltage (SELV)	DC 5V/DC 10 - 30 V	DC 5V ±10% or DC 5 - 30 V
Max. current w/o load	60 mA (DC 5V), 60 mA (DC 10 V), 35 mA (DC 24 V)	60 mA (DC 5V), 60 mA (DC 10 V), 35 mA (DC 24 V)
Max. pulse frequency	300 kHz (RS 422) 200 kHz (push-pull)	600 kHz (RS 422) 200 kHz (push-pull)
Max. output load	RS 422: ±30 mA push-pull with short circuit protection: 30 mA (DC 10 - 30 V)	RS 422: ±30 mA push-pull with short circuit protection: 40 mA (DC 5 - 30 V)
Alarm output	NPN-O.C. 5 mA	NPN-O.C. 5 mA
Pulse shape	Square wave	Square wave
Pulse duty factor	1 : 1	1 : 1
Page	74	78

Motor Feedback Systems - Hollow shaft Encoders for Asynchronous & DC Motors



Type	RIS 58-H
Special features	<ul style="list-style-type: none"> ■ harmonic distortion less than 1 % ■ extended temperature range, -40° up to +100 °C ■ 500 kHz sine-wave incremental signal frequency response ■ self-monitoring and error compensation ■ secure against short-circuit and overload
Number of pulses	1 000, 1 024, 2 048, 2 500, 5 000
Technical Data - mechanical	
Shaft diameter	10 mm, 12 mm hollow shaft
Balance tolerances	axial ±1.5 mm, radial ±0.2 mm
Max. speed	12 000 min ⁻¹
Torque	≤ 1 Ncm
Protection (EN 60529)	Bearing IP64, Housing IP65
General design	as per DIN EN 61010-1
Operating temperature	-40 ... +100 °C
Vibration (IEC 68-2-6)	≤ 100 m/s ²
Shock (IEC 68-2-27)	≤ 1 000 m/s ²
Material housing	Aluminium
Connection	Cable axial or radial Conin axial or radial
Size	Ø 58 mm
Weight approx.	270 g
Technical Data - electrical	
Supply voltage (SELV)	DC 5 V / ±10 %
Max. current w/o load	120 mA
Incremental signals A, B	Sine - Cosine 1 Vpp
Absolute accuracy	±35"
Repeatability	±7"
Max. output frequency	500 kHz
Reference signal: R	> 0,4 V (1 pulse / turn)
Page	99

Motor Feedback Systems - Hollow shaft Encoders for Asynchronous & DC Motors



Type	AC 58 - BiSS / SSI	AC 110 - BiSS / SSI
Technical Data - mechanical		
Housing diameter	58 mm	110 mm
Shaft diameter	Hub shaft 10 mm, 12 mm	up to 50 mm
Protection class shaft input	IP64 or IP67	IP50 or IP64
Protection class housing	IP64 (IP67 optional)	IP50 or IP64
Flange	Hubshaft with tether	Hollow shaft with tether
Max. speed	Continuous: 10 000 min ⁻¹ , Short term: 12 000 min ⁻¹	IP50: 3600 min ⁻¹ IP64: 1500 min ⁻¹
Shaft load	axial 40 N / radial 60 N	
Spring tether (hollow shaft)		
Tolerance axial / radial	± 1.5 mm / ± 0.2 mm	± 0.5 mm / ± 0.05 mm
Shock resistance (IEC 68-2-27)	1 000 m/s ² (6 ms)	1000 m/ s ² (6 ms)
Vibration resistance (IEC 68-2-6)	100 m/s ² (10 ... 2 000 Hz)	100 m/ s ² (10 - 500 Hz)
Operating temperature	-40 ... 100 °C	-20 ... +70 °C
Weight approx. ST/MT	260 g / 310 g	1000 g
Technical Data - electrical		
Supply voltage	DC 5 V, -5 % / + 10 % or DC 10 - 30 V	DC 5 V (-5 % / +10 %) or DC 10-30 V
Max. current w/o load ST/MT	50 mA / 100 mA	120 mA
Interface	BiSS or Standard SSI	BiSS or Standard SSI
Lines/ Drives	Clock and Data/ RS422	Clock and Data/ RS422
Output code	Binary or Gray	Binary or Gray
Linearity	±1/2 LSB (± 1 LSB for resolution > 13 Bit)	
Resolution singleturn	10-17 Bit, Gray Excess: 360, 720 steps	10 - 17 Bit
Resolution multiturn	12 Bit	only singleturn
Optional incremental signals	Sine - Cosine 1 Vpp	Sine - Cosine 1 Vpp
Number of pulses	2048	4096
3 db limiting frequency	500 kHz	500 kHz
Absolute accuracy	±35"	± 35"
Repeatability	±7"	± 7"
Parameterization	Code type, sense of rotation, warning, alarm	Code type, sense of rotation, warning, alarm
Control input	Direction	Direction
Reset key	Disable via parameterization	
Alarm output	Alarm bit (SSI option), warning bit and alarm bit (BiSS)	Alarm bit (SSI option), warning bit and alarm bit (BiSS)
Status LED	Green = OK.; red = alarm	
Connection	Cable axial or radial Conin axial or radial M12, 8 pole	Cable radial Cable with Conin-Coupling
Page	113	151

Motor Feedback Systems - Comcoders for AC Synchronous & BLDC Motors



Type	M15	M21
Special features	<ul style="list-style-type: none"> ■ through hollow shaft, diameter 3.18 ... 10 mm ■ output signals: A, B, N as incremental signals as well as 4, 6 or 8 pole commutation signals ■ external diameter 40 mm (1.5") ■ mounting depth only 28 mm (1.1") ■ max. speed up to 12 000 min⁻¹ ■ operating temperature up to 120°C 	<ul style="list-style-type: none"> ■ through hollow shaft, diameter 6 ... 12.7 mm ■ output signals: A, B, N as incremental signals as well as 4, 6, 8, 10, 12 or 16 pole commutation signals ■ external diameter 53 mm (2.1") ■ mounting depth only 20 mm (0.8") ■ max. speed up to 12 000 min⁻¹ ■ operating temperature up to 120°C
Number of pulses	200 ... 1 024	500 ... 2 048
Commutation	4, 6 or 8 pole	4, 6, 8, 10, 12 or 16 pole
Technical Data - mechanical		
Shaft diameter	Hollow shaft 3.18 ... 10 mm	Hollow shaft 6 ... 12.7 mm
Max. speed	12 000 min ⁻¹	12 000 min ⁻¹
Max. speed (continuous)		
Protection class housing/bearing	IP40/40	IP40/40 (with cover)
General design		
Operating temperature	-40 ... +120 °C	-40 ... +120 °C
Diameter	39.6 mm	53 mm
Mounting depth	27.9 mm	20.3 mm
Technical Data - electrical		
Output	NPN-O.C. / RS 422	NPN-O.C. / RS 422
Supply voltage (SELV)	DC 5 V / DC 12 V ±10%	DC 5 V / DC 2 V ±10%
Max. current w/o load	Incremental: max. 100 mA Incremental + Commutation: 120 mA	Incremental: max. 100 mA Incremental + Commutation: 175 mA
Max. pulse frequency	200 kHz	200 kHz
Max. output load	NPN-O.C. 16 mA RS 422: ±40 mA	RS 422: ±40 mA NPN-O.C. 16 mA
Max. output load commutation	NPN-O.C. 16 mA RS 422: ±40 mA	NPN-O.C. 16 mA RS 422: ±40 mA
Pulse shape	Square wave	Square wave
Phasing	90°±18° electrical	90°±18° electrical
Symmetry	180°±18° electrical	180°±18° electrical
Accuracy commutation signals	±6 arc-mins. max.	±6 arc-mins. max.
Page	191	196

Motor Feedback Systems - Comcoders for AC Synchronous & BLDC Motors

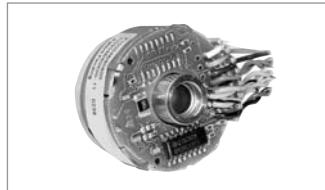

Type	F10	F15	F21
Special features	<ul style="list-style-type: none"> ■ through hollow shaft, diameter 6 mm ■ output signals: A, B, N as incremental signals as well as 6 or 10 pole commutation signals ■ resolution up to 2 048 ppr ■ frequency response to 300 kHz ■ resolver compatible mounting ■ operating temperature up to 120 °C 	<ul style="list-style-type: none"> ■ through hollow shaft, diameter 9.52 mm ■ output signals: A, B, N as incremental signals as well as 6, 8 or 10 pole commutation signals ■ resolution up to 2 048 ppr ■ frequency response to 300 kHz ■ resolver compatible mounting ■ operating temperature up to 120 °C 	<ul style="list-style-type: none"> ■ through hollow shaft, diameter 12.7 mm ■ output signals: A, B, N as incremental signals as well as 6, 8, 10, 12 or 16 pole commutation signals ■ resolution up to 2 048 ppr ■ frequency response to 300 kHz ■ resolver compatible mounting ■ operating temperature up to 120 °C
Number of pulses	1 024, 2 048	1 024, 2 048	1 024, 2 048
Commutation	6 or 10 pole	6, 8 or 10 pole	6, 8, 10, 12 or 16 pole
Technical Data - mechanical			
Shaft diameter	Hollow shaft 6 mm	Hollow shaft 9.52 mm	Hollow shaft 12.7 mm
Max. speed	12 000 min ⁻¹	12 000 min ⁻¹	12 000 min ⁻¹
Max. speed (continuous)	5 000 min ⁻¹	5 000 min ⁻¹	5 000 min ⁻¹
Protection class housing/bearing	---	---	---
General design			
Operating temperature	0° ... +120 °C	0° ... +120 °C	0° ... +120 °C
Diameter	31.7mm max.	36.8 mm max.	53 mm max.
Mounting depth	22.5 mm	22.4 mm	26 mm max.
Technical Data - electrical			
Output	RS422	RS422	RS422
Supply voltage (SELV)	DC 5 V ±10 %	DC 5 V ±10 %	DC 5 V ±10 %
Max. current w/o load	100 mA max.	100 mA max.	100 mA max.
Max. pulse frequency	300 kHz	300 kHz	300 kHz
Max. output load	RS422: ±40mA,	RS422: ±40mA,	RS422: ±40mA,
Max. output load commutation	O.C.: 8mA or RS 422: ±40mA,	O.C.: 8mA or RS 422: ±40mA,	O.C.: 8mA or RS422: ±40mA,
Pulse shape	Square wave	Square wave	Square wave
Accuracy incremental signals	±2.5 arc-mins.	±2.5 arc-mins.	±2.5 arc-mins.
Accuracy commutation signals	±6 arc-mins. max.	±6 arc-mins. max.	±6 arc-mins. max.
Page	201	205	209

Motor Feedback Systems - Comcoders for AC Synchronous & BLDC Motors

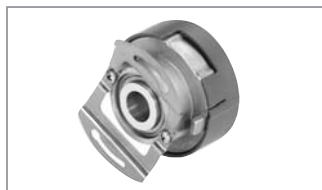
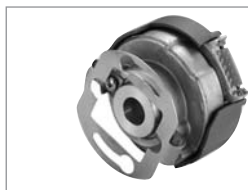

Type	F14	F18
Special features	<ul style="list-style-type: none"> ■ through hollow shaft, diameter 6 ... 8mm ■ Phased Array Technology ■ resolution up to 5 000 ppr ■ with 4, 6, 8 and 10 pole commutation signals ■ frequency response to 500 kHz ■ stator coupling ■ resolver compatible mounting (optional) ■ external diameter 40 mm ■ operating temperature up to +120°C 	<ul style="list-style-type: none"> ■ through hollow shaft, diameter 6 ... 12.7 mm ■ Phased Array Technology ■ resolution up to 10 000 ppr ■ with 4, 6, 8, 10, 12 and 16 pole commutation signals ■ frequency response to 500 kHz ■ stator coupling ■ external diameter 50 mm ■ operating temperature up to +120°C
Number of pulses	200 ... 5 000	500 ... 10 000
Commutation	4, 6, 8 or 10 pole	4, 6, 8, 10, 12 or 16 pole
Technical Data - mechanical		
Shaft diameter	Hollow shaft 6 ... 8 mm	Hollow shaft 6 ... 12.7 mm
Max. speed	12 000 min ⁻¹	12 000 min ⁻¹
Max. speed (continuous)		
Protection class housing/bearing	IP40/40 (with cover)	IP40/40 (with cover)
General design		
Operating temperature	0° ... +120 °C	0° ... +120 °C
Diameter	39.4 mm	49.7 mm
Mounting depth	34.6 mm max.	43.4 mm max.
Technical Data - electrical		
Output	O.C. or RS 422	O.C. or RS 422
Supply voltage (SELV)	DC 5 V ±10 %	DC 5 V ±10 %
Max. current w/o load	Incremental: max. 150 mA Incremental + Commutation: 175 mA	Incremental: max. 150 mA Incremental + Commutation: 175 mA
Max. pulse frequency	500 kHz	500 kHz
Max. output load	RS 422: ±40 mA NPN-O.C. 16 mA	RS 422: ±40 mA NPN-O.C. 16 mA
Max. output load commutation	NPN-O.C. 16 mA RS 422: ±40 mA	NPN-O.C. 16 mA RS 422: ±40 mA
Pulse shape	Square wave	Square wave
Accuracy incremental signals	±2.5 arc-mins.	±2.5 arc-mins.
Accuracy commutation signals	±6 arc-mins. max.	±6 arc-mins. max.
Page	213	217

Motor Feedback Systems - Comcoders for AC Synchronous & BLDC Motors



Type	RF53
Special features	<ul style="list-style-type: none"> ■ Solid shaft motor encoder for BLDC and gearless elevator traction machines ■ Incremental & Commutation ■ up to 10 000 ppr ■ up to +120 °C operating temperature ■ IP54 ■ Housing diameter 53 mm
Number of pulses	500 ... 10 000
Commutation	4, 6, 8, 10, 12,16, 20, 24 or 32 pole
Technical Data - mechanical	(preliminary)
Housing diameter	53 mm
Shaft	cone solid shaft
Flange	spring tether
Protection class housing/bearing	IP54
Shaft load axial/ radial	20 / 90 N
Axial runout of mating shaft	±1.4 mm
Radial runout of mating shaft	±0.18 mm
Max. speed	12 000 U/min (short term) 5 000 U/min (continuous)
Max. operating temperature	-20°C ... +120°C
Vibration resistance	1000 m/s ²
Shock resistance	25 m/s ²
Material shaft / housing	Stainless steel / Aluminium
Weight	200 g
Connection	Sub-D connector PCB-connector with mating connector and cable
Technical Data - electrical	(preliminary)
Output	O.C-NPN. or RS 422
Supply voltage	DC 5 ±10%
Max. current w/o load	100 mA
Code	Incremental with commutation option, optical
Tolerance Incremental signals	±2,5 arc-mins. max. (edge to edge)
Tolerance Commutation	±6 arc-mins. max.
Output frequency	max. 100 kHz
Output circuit	Differential line driver (ET7272), 40 mA max. Open Collector, max. 8 mA; Pull up mit 2,0 kOhm
Page	221

Motor Feedback Systems - Absolute Encoders for AC Synchronous & BLDC Motors



Type	AD 36	AD 58	AC 110
Technical Data - mechanical			
Housing diameter	37.5mm	58 mm	110 mm
Shaft diameter	8 mm	Cone 10 mm	up to 50 mm
Protection class shaft input	IP40	IP40	IP50 or IP64
Protection class housing	IP40	IP40	IP50 or IP64
Flange	Hollow shaft with tether	Hollow shaft with tether, tapered shaft	Hollow shaft with tether
Max. speed	Continuous 10 000 min ⁻¹ , Short term 12 000 min ⁻¹	Continuous 10 000 min ⁻¹ , Short term 12 000 min ⁻¹	IP50: 3600 min ⁻¹ IP64: 1500 min ⁻¹
Shaft load	0.01 Nm	0.01 Nm	
Torque	2.5 x 10 ⁻⁶ kgm ²	3.8 x 10 ⁻⁶ kgm ²	
Spring tether (hollow shaft) Tolerance axial / radial	± 0.5 mm/ ±0.05 mm	± 1.5 mm/ ±0.2 mm	± 0.5 mm / ± 0.05 mm
Shock resistance (IEC 68-2-27)	1 000 m/s ² (6 ms)	1 000 m/s ² (6 ms)	1000 m/ s ² (6 ms)
Vibration resistance (IEC 68-2-6)	100 m/s ² (10 ... 2 000 Hz)	100 m/s ² (10 ... 2 000 Hz)	100 m/ s ² (10 - 500 Hz)
Operating temperature	-25 ... +100 °C	-15 ... +120 °C	-20 ... +70 °C
Weight approx. ST/MT	80 g / 130 g	216 g / 310 g	1000 g
Technical Data - electrical			
Supply voltage	DC 5 V (-5 % / +10 %) or DC 7-30 V	DC 5 V, -5 % / + 10 %	DC 5 V (-5 % / +10 %) or DC 10-30 V
Max. current w/o load ST/MT	50 mA / 100 mA	50 mA / 100 mA	120 mA
Interface	BiSS or Standard SSI	BiSS or Standard SSI	
Lines/ Drives	Clock and Data / RS422	Clock and Data / RS422	Clock and Data/ RS422
Output code	Binary or Gray	Binary or Gray	Binary or Gray
Resolution singleturn	12 - 17 Bit (SSI), 12 - 19 Bit (BiSS)	13 Bit (SSI) ... max. 22 Bit (BiSS)	10 - 17 Bit
Resolution multiturn	12 Bit	12 Bit	only singleturn
Optional incremental signals	Sine - Cosine 1 Vpp	Sine - Cosine 1 Vpp	Sine - Cosine1 Vpp
Number of pulses	2048	2048	4096
3 db limiting frequency	500 kHz	500 kHz	500 kHz
Absolute accuracy	±35"	±35"	± 35"
Repeatability	±7"	±7"	± 7"
Alarm output	Alarm bit (SSI), warning bit and alarm bit (BiSS)	alarm bit (SSI), warning bit and alarm bit (BiSS)	alarm bit (SSI), warning bit and alarm bit (BiSS)
Connection	Cable PCB-Connector 12 pole	Cable PCB-Connector 12 pole	Cable radial Cable with Conin-Coupling
Page	225	228	151

Motor Feedback Systems - Sine-wave Encoders for AC Synchronous & BLDC Motors



Type	S21
Special features	<ul style="list-style-type: none"> ■ operating temperature range of -15 up to +120 °C ■ 500 kHz limiting frequency with excellent signal quality ■ excellent immunity to interference (EN 61000-4-4, Class 4) ■ signal control and system monitoring ■ high signal quality through control and error compensation
Technical Data - mechanical	
Shaft form	Cone 1/10
Shaft variations	Tapered solid shaft (Tapered hollow shaft on request)
Shaft diameter	10 mm
Absolute max. shaft load radial / axial	with tapered solid shaft: 90 N / 20 N
Balance tolerances	axial ± 0.5 mm, radial ± 0.1 mm
Max. speed	12.000 min ⁻¹
Torque	≤ 1 Ncm
Protection class (EN 60529)	IP40
General design	as per DIN EN 61010-1
Operating temperature	-15 ... +120 °C
Vibration resistance (IEC 68-2-6)	≤ 100 m/s ²
Shock resistance (IEC 68-2-27)	≤ 1000 m/s ²
Material housing	Aluminium
Connection	PCB connector + cable
Size	Ø 53.5 mm
Weight approx.	170 g
Technical Data - electrical	
Supply voltage (SELV)	DC 5 V ±10 %
Max. current w/o load	max. 120 mA
Incremental signals A, B	Sine - Cosine 1 Vpp
Number of pulses	2048
Absolute accuracy	±35"
Repeatability	±7"
Max. output frequency	500 kHz
Reference signal: R	> 0.4 V (1pulse / turn)
Commutation signal: C, D	Sine - Cosine 1 Vpp (1 period / turn)
Page	231

Motor Feedback Systems - Resolver for AC Synchronous & BLDC Motors



Type	Resolvers
Special features	<ul style="list-style-type: none"> ■ Through hollow shaft, diameter 4 up to 92 mm ■ compact design ■ easy and quick mounting procedure (standardized resolver mounting) ■ Operating temperature up to 155 °C ■ Applications, e.g. motors, machine tools, robots, automated SMD equipment, medical technology
Number of pulses	Drive or external electronics
Commutation	Drive or external electronics
Technical Data - mechanical	
Shaft diameter	Hollow shaft 4.0 .. 92.7 mm
Max. speed	20 000 min ⁻¹ (special: >30 000 min ⁻¹)
Max. speed (continuous)	
Protection class housing/bearing	---
General design	
Operating temperature	-25 ... +155 °C
Diameter	Ø 26.5 ... 139.7 mm
Mounting depth	16.5 ... 31.8 mm
Technical Data - electrical	
Output	depends on input signal
Supply voltage (SELV)	
Max. current w/o load	
Max. pulse frequency	
Max. output load	
Max. output load commutation	
Pulse shape	Sine
Tolerance	typical +/- 10°
Accuracy commutation signals	---
Page	234

Application Examples for Encoders

Encoder Applications:

- Packaging industry
- Food industry
- Medical technology
- Elevators
- Conveyor systems
- Robotics
- Cranes
- Positioning control
- Electronics
- Baggage conveyor systems
- Metalworking
- Motors
- Servo motors
- Vector drives
- Mechanical engineering
- Turning machines
- Stamping machines
- Bending machines
- Welding systems
- Sawing machines
- etc.

Application Examples with Encoders

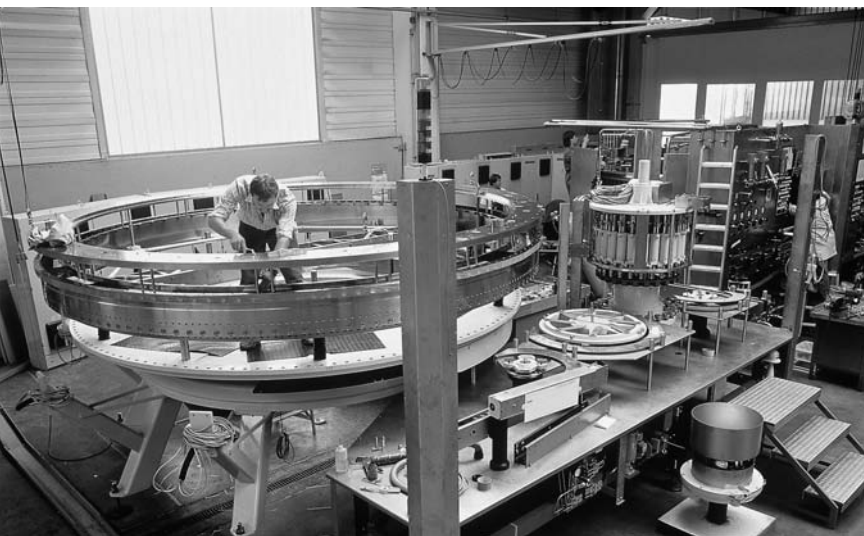
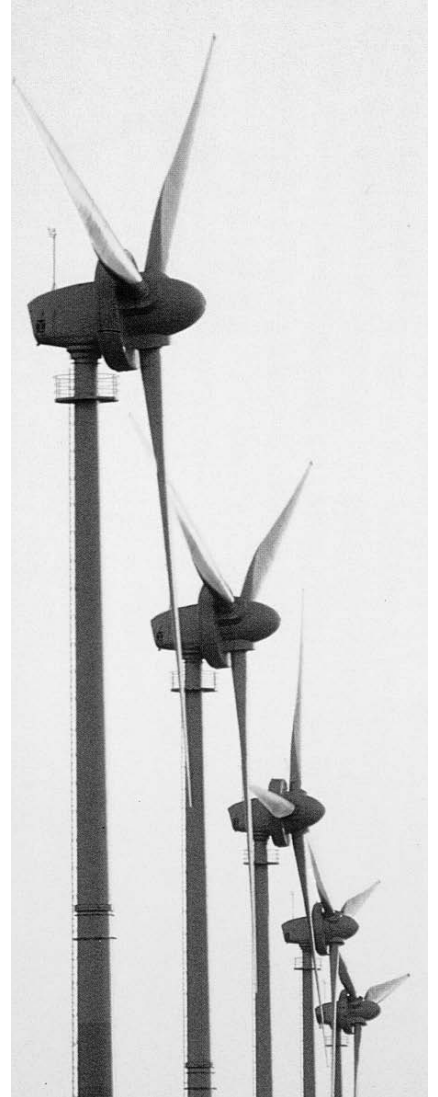

Application Examples with Motor Encoders



Notes

Incremental Encoders



Incremental encoders are sensors capable of generating signals in response to rotary movement. In conjunction with mechanical conversion devices, such as rack-and-pinions, measuring wheels or spindles, incremental shaft encoders can also be used to measure linear movement. The shaft encoder generates a signal for each incremental change in position.

With the optical transformation, a line-coded disc made of metal, plastic or glass and positioned on a rotary bearing interrupts the infra red light ray emitted by gallium arsenid sender diode. The number of lines determines the resolution, i.e. the measuring points within a revolution. The interruptions of the light ray are sensed by the receptor element and electronically processed. The information is then made available as a rectangular signal at the encoder output.

Examples for typical applications of incremental encoders:

- Door closing devices for trains
- Desktop robots
- Lens grinding machines
- Plotters
- Testing machines for optical waveguides
- Scattering machines
- Tampon printing machines
- Ultrasonic welding
- Screwing machines
- Labelling machines
- x/y indication
- Analysis devices
- Drilling machines
- Mixing machines

Incremental Encoders - Industrial types

Solid shaft



Incremental Encoders

Type	RI 30	RI 36	RI 58
Special features	<ul style="list-style-type: none"> ■ small encoder for industrial applications ■ low power consumption ■ high immunity to interference ■ cable lengths up to 100 m ■ suitable for high pulse frequencies ■ high level of protection ■ applications, e.g. CNC machine, handling systems, motors, medical technology, textile machinery 	<ul style="list-style-type: none"> ■ small industrial encoder for high numbers of pulses ■ high operating safety ■ applications, e.g. CNC axles, machine tools, robots, special machinery, high-speed winding machines 	<ul style="list-style-type: none"> ■ universal industrial encoder ■ up to 10 000 pulses ■ protection class up to IP67 ■ operating temperature up to 100°C ■ suitable for high shock loads ■ applications e.g. machine tools, CNC axles, packaging machinery, motors, drives, injection moulding machines, sawing machines, textile machinery
Number of pulses	5 ... 1500	5 ... 3600	1 ... 10000
Technical Data - mechanical			
Flange	S = synchro flange, R = pilot flange	S = synchro flange, R = pilot flange	S = synchro flange, K = pilot flange, Q = square flange, M = Synchro clamping flange
Shaft diameter	5 mm	6 / 6.35 mm	6 / 6.35 / 7 / 10 / 9.52 / 12 mm
Absolute max. shaft load radial/axial	10/5 N	10/5 N	Ø 12 mm - 80/60 N Ø 7 ... 10 mm - 60/40 N Ø 6 mm / 6.35 mm - 40/20 N
Absolute max. speed	10 000 min ⁻¹	10 000 min ⁻¹	10 000 min ⁻¹
Torque	≤ 0.2 Ncm	≤ 0.3 Ncm	≤ 0.5 Ncm
Protection class housing/bearing	IP64/64	IP64/64	IP65/64, IP67/67
General design	as per DIN VDE 0160, protection class III	as per DIN VDE 0160, protection class III	as per DIN VDE 0160, protection class III
Operating temperature	-10 ... +70 °C	-10 ... +70 °C	RI 58-O: -10 ... +70 °C/ RI 58-T: -25 ... +100 °C
Connection	Cable axial/radial	Cable or connector axial/radial	Cable or connector axial/radial
Size	Ø 30 mm	Ø 36 mm	Ø 58 mm, square fl.=63.5 mm/80mm
Weight approx.	60 g	80 g	300 g
Technical Data - electrical			
Output	RS 422 / push-pull	RS 422 / push-pull	RS 422 / push-pull / push-pull complementary
Supply voltage (SELV)	DC 5 V / DC 10 - 30 V	DC 5 V / DC 10 - 30 V	DC 5 V / DC 10 - 30 V
Max. current w/o load	40 mA (DC 5 V), 30 mA (DC 24 V), 60 mA (DC 10 V)	40 mA (DC 5 V), 30 mA (DC 24 V), 60 mA (DC 10 V)	40 mA (DC 5 V), 30 mA (DC 24 V), 60 mA (DC 10 V)
Max. pulse frequency	300 kHz (RS 422) 200 kHz (push-pull)	300 kHz (RS 422) 200 kHz (push-pull)	300 kHz (RS 422) 200 kHz (push-pull)
Output load	RS 422: ±30 mA push-pull with short circuit protection: 30 mA (DC 10 - 30 V)	RS 422: ±30 mA push-pull with short circuit protection: 30 mA (DC 10 - 30 V)	RS 422: ±30 mA push-pull with short circuit protection: 30 mA (DC 10 - 30 V)
Alarm output	NPN-O.C. 5 mA	NPN-O.C. 5 mA	NPN-O.C. 5 mA
Pulse shape	Square wave	Square wave	Square wave
Pulse duty factor	1 : 1	1 : 1	1 : 1
Page	47	51	54

Incremental Encoders - Industrial types

Hollow shaft



Type	RI 36-H	RI 58-H	RI 58-D
Special features	<ul style="list-style-type: none"> ■ miniature industry encoder for high numbers of pulses ■ short mounting depth ■ easy mounting procedure ■ applications, e.g. motors, machine tools, packaging machines, robots, automated SMD equipment 	<ul style="list-style-type: none"> ■ through hollow shaft ■ high accuracy due to integrated coupling ■ secure shaft mounting ■ applications e.g. textile machinery, motors, drives, copiers 	<ul style="list-style-type: none"> ■ direct mounting without coupling ■ flexible hollow shaft concept up to 14 mm ■ through hollow shaft or as end shaft (blind shaft) ■ operating temperature up to 100 °C (RI 58 TD) ■ applications, e.g. positioning drives, motors
Number of pulses	5 ... 3600	1 ... 5000	1 ... 5000
Technical Data - mechanical			
Flange or shaft fixing	Clamping shaft (one side open) with front clamping ring; hubshaft with tether as torque support	S = synchro flange	E = synchro flange with blind shaft F, D, H= synchro flange with clamping shaft
Shaft diameter	Hollow shaft 4 / 6 / 8 / 10 mm	Hollow shaft 10 mm/12 mm	Hollow shaft 10 mm/12 mm/14 mm
Absolute max. shaft load	misalignment radial ± 0.15 mm, misalignment axial ± 0.5 mm,	misalignment axial ± 0.4 mm misalignment parallel 0,4 mm misalignment angular 1°	
Absolute max. speed	10000 min ⁻¹	3000 min ⁻¹	6000 min ⁻¹
Torque	≤ 0.3 Ncm	≤ 2 Ncm	≤ 1.7 Ncm
Protection class housing/bearing	IP64/64	IP64/64	IP65/64
General design	as per DIN VDE 0160, protection class III	as per DIN VDE 0160, protection class III	as per DIN VDE 0160, protection class III
Operating temperature	-10 ... +70 °C	-10 ... +70 °C	-10 ... +70 °C (Option: -25 .. +100 °C)
Connection	Cable axial/radial	Cable radial	Cable or connector radial
Size	Ø 36 mm	Ø 58 mm	Ø 58 mm
Weight approx.	80 g	210 g	170 g
Technical Data - electrical			
Output	RS 422/push-pull/ push-pull complementary	RS 422/push-pull/ push-pull complementary	RS 422/push-pull/ push-pull complementary
Supply voltage (SELV)	DC 5 V/DC 10 - 30 V	DC 5 V/DC 10 - 30 V	DC 5 V/DC 10 - 30 V
Max. current w/o load	40 mA (DC 5 V), 30 mA (DC 24 V), 60 mA (DC 10 V)	40 mA (DC 5 V), 30 mA (DC 24 V), 60 mA (DC 10 V)	40 mA (DC 5 V), 30 mA (DC 24 V), 60 mA (DC 10 V)
Max. pulse frequency	300 kHz (RS 422) 200 kHz (push-pull)	300 kHz (RS 422) 200 kHz (push-pull)	300 kHz (RS 422) 200 kHz (push-pull)
Output load	RS 422: ± 30 mA push-pull with short circuit protection: 30 mA (DC 10 - 30 V)	RS 422: ± 30 mA push-pull with short circuit protection: 30 mA (DC 10 - 30 V)	RS 422: ± 30 mA push-pull with short circuit protection: 30 mA (DC 10 - 30 V)
Alarm output	NPN-O.C. 5 mA	NPN-O.C. 5 mA	NPN-O.C. 5 mA
Pulse shape	Square wave	Square wave	Square wave
Pulse duty factor	1 : 1	1 : 1	1 : 1
Page	62	65	68

Incremental Encoders - Industrial types

Hollow shaft



Type	RI 76 TD	RI 80-E
Special features	<ul style="list-style-type: none"> ■ through hollow shaft ■ shaft diameters 15 to 42 mm ■ external diameter only 76 mm ■ simple installation with clamping ring front or rear ■ operating temperature up to 100 °C ■ applications e.g. motors, printing machines, elevators 	<ul style="list-style-type: none"> ■ Incremental Output ■ 30...45 mm hollow shaft ■ Rugged mechanical design ■ Unbreakable disc ■ Integrated diagnostic system ■ Wide voltage range DC 5 ... 30 V
Number of pulses	1 ... 10 000	1024, 2048, 4096 other number of pulses on request
Technical Data - mechanical		
Shaft fixation	Clamping ring front or rear	Keyway, set screw
Coupling	stator coupling (hubshaft with tether)	Spring tether (single, double)
Shaft diameter	Hollow shaft 15 ... 42 mm	
Max. speed	6 000 min ⁻¹ (depends on version)	3 600 min ⁻¹ (IP50), 1 500 min ⁻¹ (IP64)
Torque	3 ... 10 Ncm (depends on version)	
Protection class housing/bearing	IP50/40 (Option: IP65/64)	IP50, IP64
General design	as per DIN EN 61010, protection class III, Contamination level 2, over voltage class II	as per DIN EN 61010, protection class III, Contamination level 2, over voltage class II
Operating temperature	-25 ... +100 °C	-20 ... +70 °C
Connection	Cable radial	Sub-D 15p. / cable, radial
Size	Ø 76 mm	
Weight approx.	320 ... 580 g (depends on version)	1 000 g
Technical Data - electrical		
Output	RS 422/push-pull / push-pull complementary	RS 422/push-pull / push-pull complementary
Supply voltage (SELV)	DC 5 V / DC 10 - 30 V	DC 5 V ±10% or DC 5 - 30 V
Max. current w/o load	60 mA (DC 5 V), 60 mA (DC 10 V), 35 mA (DC 24 V)	60 mA (DC 5 V), 60 mA (DC 10 V), 35 mA (DC 24 V)
Max. pulse frequency	300 kHz (RS 422) 200 kHz (push-pull)	600 kHz (RS 422) 200 kHz (push-pull)
Output load	RS 422: ±30 mA push-pull with short circuit protection: 30 mA (DC 10 - 30 V)	RS 422: ±30 mA push-pull with short circuit protection: 40 mA (DC 5 - 30 V)
Alarm output	NPN-O.C. 5 mA	NPN-O.C. 5 mA
Pulse shape	Square wave	Square wave
Pulse duty factor	1 : 1	1 : 1
Page	74	78

Incremental Encoders - Economy types



Type	PC 9 / PC 9S
Special features	<ul style="list-style-type: none"> ■ Provides digital control inputs from operators's panel ■ Bidirectional squarewave signal outputs ■ Up to 512 increments ■ Continuous and reversible rotation ■ Noncontacting ■ Operating temperature -40 ... 100 °C
Number of pulses	100 ... 512
Technical Data - mechanical	
Absolute max. shaft load	1/8" Shaft: 4 N axial, 27 N radial 1/4" Shaft: 4 N axial, 4 N radial
Moment of inertia	0.20 gcm ²
Operating temperature	-40 ... +100 °C
Storage temperature	-50 ... +125 °C
Relative humidity	90 %, non-condensing
Connection	PC9: 10 pole header, (Accessory: 30 cm ribbon cable with connector) PC9S: 5 pole header, (Accessory: 30 cm cable with connector)
Technical Data - electrical	
Code	Inkremental, optical
Phasing	90° ±18° electrical
Symmetry	180° ±18° electrical
Index pulse width	90° ±36° electrical
Supply voltage	DC 5 V ±10 %
Supply current	10 mA, typical
Standby current	max. 50 µA (PC9 only)
Output signals	min. 2.5 V high (V _{OH}) max. 0.5 V low (V _{OL})
Output current	PC9: 3 mA sink/source (25 °C), 2 mA (100 °C) PC9S: 6 mA sink/source (25 °C), 4 mA (100 °C)
Max. pulse frequency	200 kHz
Pulse shape	Square wave
Pulse duty factor	1:1
Page	81

Incremental Encoders - Economy types



Type	RI 32	RI 38	RI 41
Special features	<ul style="list-style-type: none"> ■ economy encoder for small devices ■ long life due to ball bearings ■ low torque ■ application e.g. laboratory devices, fitness machines, crimping machines, tampon printing machines, small grinding machines 	<ul style="list-style-type: none"> ■ encoder for universal mounting due to front or rear fixing ■ long life due to ball bearings ■ low torque ■ applications e.g. small motors, laboratory devices, labelling devices, plotters, length measuring machines 	<ul style="list-style-type: none"> ■ economy encoder ■ high mechanical life ■ applications e.g. small motors, graphic machines, desktop robots, wood working machines
Number of pulses	5 ... 1500	5 ... 1024	5 ... 3600
Technical Data - mechanical			
Flange	R = pilot flange	Q = square flange	R = pilot flange
Shaft diameter	5 mm/6 mm	6 mm	6 mm
Absolute max. shaft load	radial 10 N, axial 5 N	radial 10 N, axial 5 N	radial 10 N, axial 5 N
Absolute max. speed	6 000 min ⁻¹	10 000 min ⁻¹	10 000 min ⁻¹
Torque	≤ 0.05 Ncm	≤ 0.2 Ncm	
Protection class housing/bearing	IP50/40	IP50/40	IP50/40
General design	as per DIN VDE 0160, protection class III	as per DIN VDE 0160, protection class III	as per DIN VDE 0160, protection class III
Operating temperature	-10° ... +60 °C	-10° ... +60 °C	-10° ... +70 °C
Connection	Cable radial/axial	Cable radial	Cable radial
Size	Ø 30 mm	39 x 39 mm	Ø 40 mm
Weight approx.	50 g	60 g	60 g
Technical Data - electrical			
Output	push-pull	push-pull	push-pull
Supply voltage (SELV)	DC 5 V or DC 10 - 30 V	DC 5 V or DC 10 - 30 V	DC 5 V or DC 10 - 30 V
Max. current w/o load	40 mA (DC 5 V), 30 mA (DC 24 V)	40 mA (DC 5 V), 30 mA (DC 24 V)	40 mA (DC 5 V), 30 mA (DC 24 V)
Max. pulse frequency	300 kHz (DC 5 V) 200 kHz (DC 10 - 30 V)	300 kHz (DC 5 V) 200 kHz (DC 10 - 30 V)	300 kHz (DC 5 V) 200 kHz (DC 10 - 30 V)
Output load	push-pull with short circuit protection: 10 mA (DC 5 V), 30 mA (DC 10 - 30 V)	push-pull with short circuit protection: 10 mA (DC 5 V), 30 mA (DC 10 - 30 V)	push-pull with short circuit protection: 10 mA (DC 5 V), 30 mA (DC 10 - 30 V)
Alarm output	NPN-O.C. 5 mA	NPN-O.C. 5 mA	NPN-O.C. 5 mA
Pulse shape	Square wave	Square wave	Square wave
Pulse duty factor	1 : 1	1 : 1	1 : 1
Page	84	86	88

Incremental Encoders - Economy types



Type	RI 42
Special features	<ul style="list-style-type: none"> ■ economy encoder ■ high protection IP65 ■ push-pull or NPN-O.C. ■ applications, e.g. textile machinery
Number of pulses	5 ... 1 024
Technical Data - mechanical	
Flange	R = pilot flange
Shaft diameter	6 mm
Absolute max. shaft load	radial 10 N, axial 5 N
Absolute max. speed	10 000 min ⁻¹
Torque	≤ 1 Ncm
Protection class housing/bearing	IP65/64
General design	as per DIN VDE 0160, protection class III
Operating temperature	0° ... +60 °C
Connection	Cable axial
Size	Ø 40 mm
Weight approx.	75 g
Technical Data - electrical	
Output	push-pull / push-pull complementary / NPN-O.C.
Supply voltage (SELV)	DC 5 V / DC 10 - 30 V / DC 10 - 24 V
Max. current w/o load	40 mA (DC 5 V), 30 mA (DC 24 V)
Max. pulse frequency	300 kHz (DC 5 V) 200 kHz (DC 10 - 30 V) 50 kHz (DC 10 - 24 V)
Output load	push-pull with short circuit protection: 10 mA (DC 5 V), 30 mA (DC 10 - 30 V)
Alarm output	NPN-O.C. 5 mA
Pulse shape	Square wave
Pulse duty factor	1 : 1
Page	90

Incremental EX and Stainless Steel Encoders



Type	RX 70-TI / RX 71-TI (Stainless)	RI 59
Special features	<ul style="list-style-type: none"> ■ explosion-proof according to EX II 2 G/D EEX d IIC T6/T4 ■ highest operating safety ■ applications e.g. lacquering lines, surface processing machines, filling plants, mixing machines, silo systems 	<ul style="list-style-type: none"> ■ stainless steel encoder with high degree of protection ■ high corrosion resistance ■ suitable for use in food production ■ applications e.g. packaging machinery, filling plants, washing systems, mixing machines
Number of pulses	1 ... 10 000	1 ... 10 000
Technical Data - mechanical		
Flange	K = clamping flange	Q = square flange
Shaft diameter	10 mm	9.52 mm / 10 mm
Max. shaft load	radial 100 N, axial 40 N	radial 60 N, axial 40 N
Max. speed	6 000 min ⁻¹ (T6), 10 000 min ⁻¹ (T4)	10 000 min ⁻¹
Torque	≤ 0.5 Ncm	≤ 0.5 Ncm
Protection class housing/bearing	IP65/64	IP67/67
General design	as per DIN VDE 0160, protection class III	as per DIN VDE 0160, protection class III
Operating temperature	-10 ... + 40 °C	-10 ... + 70 °C
Connection	Cable axial	Cable radial
Size	Ø 70 mm	Ø 58 mm, square flange = 63.5 mm
Weight approx.	1400 g	620 g
Technical Data - electrical		
Output	RS 422 / push-pull / push-pull complementary	RS 422 / push-pull / push-pull complementary
Supply voltage (SELV)	DC 5 V / DC 10 - 30 V	DC 5 V / DC 10 - 30 V
Max. current w/o load	40 mA (DC 5 V), 30 mA (DC 24 V), 60 mA (DC 10 V)	40 mA (DC 5 V), 30 mA (DC 24 V), 60 mA (DC 10 V)
Max. pulse frequency	300 kHz (RS 422) 200 kHz (push-pull)	300 kHz (RS 422) 200 kHz (push-pull)
Output load	RS 422: ±30 mA push-pull with short circuit protection: 30 mA (DC 10 - 30 V)	RS 422: ±30 mA push-pull with short circuit protection: 30 mA (DC 10 - 30 V)
Alarm output	NPN-O.C. 5 mA	NPN-O.C. 5 mA
Pulse shape	Square wave	Square wave
Pulse duty factor	1 : 1	1 : 1
Pulse width error	± max. 25° electrical	± max. 25° electrical
Page	92	95

Incremental Sine-Wave Encoders



Type	RIS 58-0	RIS 58-H
Special features	<ul style="list-style-type: none"> ■ Harmonic distortion less than 1 % ■ Extended temperature range, -40° up to +100 °C ■ 500 kHz sine-wave incremental signal frequency response ■ Self-monitoring and error compensation ■ Secure against short-circuit and overload 	<ul style="list-style-type: none"> ■ Harmonic distortion less than 1 % ■ Extended temperature range, -40° up to +100 °C ■ 500 kHz sine-wave incremental signal frequency response ■ Self-monitoring and error compensation ■ Secure against short-circuit and overload
Number of pulses	1 000, 1 024, 2 048, 2 500 (other number of pulses on request)	1 000, 1 024, 2 048 (other number of pulses on request)
Technical Data - mechanical		
Shaft diameter	6 mm	10 mm, 12 mm hollow shaft
Absolute max. shaft load	radial 60 N/ axial 40 N	
Balance tolerances		axial ±1.5 mm, radial ±0.2 mm
Max. speed	12 000 min ⁻¹	12 000 min ⁻¹
Torque	≤ 1 Ncm	≤ 1 Ncm
Protection (EN 60529)	Bearing IP64, Housing IP65	Bearing IP64, Housing IP65
General design	as per DIN EN 61010-1	as per DIN EN 61010-1
Operating temperature	-40 ... +100 °C	-40 ... +100 °C
Vibration (IEC 68-2-6)	≤ 100 m/s ²	≤ 100 m/s ²
Shock (IEC 68-2-27)	≤ 1 000 m/s ²	≤ 1 000 m/s ²
Material housing	Aluminium	Aluminium
Connection	Cable axial or radial Conin axial or radial	Cable axial or radial Conin axial or radial
Size	Ø 58 mm	Ø 58 mm
Weight approx.	265 g	270 g
Technical Data - electrical		
Supply voltage (SELV)	DC 5 V / ±10 %	DC 5 V / ±10 %
Max. current w/o load	120 mA	120 mA
Incremental signals A, B	Sine - Cosine 1 Vpp	Sine - Cosine 1 Vpp
Absolute accuracy	±35"	±35"
Repeatability	±7"	±7"
Max. frequency	500 kHz	500 kHz
Reference signal: R	> 0,4 V (1 pulse / turn)	> 0,4 V (1 pulse / turn)
Page	97	99

Industrial types

Solid shaft



- Miniature encoder for industrial use
- Low current consumption
- High noise interference immunity
- Cable lengths of up to 100 m
- Suitable for high pulse frequencies
- High protection class
- Application e.g.:
CNC machines, manipulators, motors,
medical technology, textile machines

NUMBER OF PULSES

5 / 10 / 20 / 25 / 30 / 50 / 60 / 100 / 120 / 128 / 200 / 250 / 256 / 288 / 300 / 360 / 400 / **500 / 512** / 600 / 720 / 900 / **1000** / 1024 / 1250 / 1500

Other number of pulses on request

Preferably available versions are printed in bold type.

TECHNICAL DATA mechanical

Shaft diameter	5 mm
Absolute max. shaft load	radial 10 N, axial 5 N
Absolute max. speed	max. 10 000 min ⁻¹
Torque	≤ 0.2 Ncm
Moment of inertia	approx. 0.8 gcm ²
Protection class (EN 60529)	Housing IP64, bearings IP64
Operating temperature	-10 ... +70 °C
Storage temperature	-25 ... +85 °C
Vibration resistance	100 m/s ² (10 ... 2000 Hz)
Shock resistance	1 000 m/s ² (6 ms)
Connection	1.5 m cable radial/axial ¹ , connector axial
Housing	Aluminium
Flange	S = synchro flange, R = pilot flange
Weight	approx. 60 g

¹ Other cable length on request

TECHNICAL DATA electrical

General design	as per DIN VDE 0160, protection class III, contamination level 2, overvoltage class II	
Supply voltage (SELV)	with RS 422 (R, T): DC 5 V ± 10 % with push-pull (K): DC 10 - 30 V ²	
Max. current w/o load	40 mA (DC 5 V), 60 mA (DC 10 V), 30 mA (DC 24 V)	
Standard-output versions ³	RS 422 (R)	A, B, N, \overline{A} , \overline{B} , \overline{N} , Alarm
	RS 422 (T)	A, B, N, \overline{A} , \overline{B} , \overline{N} , Sense
	push-pull (K)	A, B, N, Alarm

² Pole protection

³ Output description and technical data see chapter "Technical basics"

DIMENSIONAL DRAWINGS

Synchro flange, cable

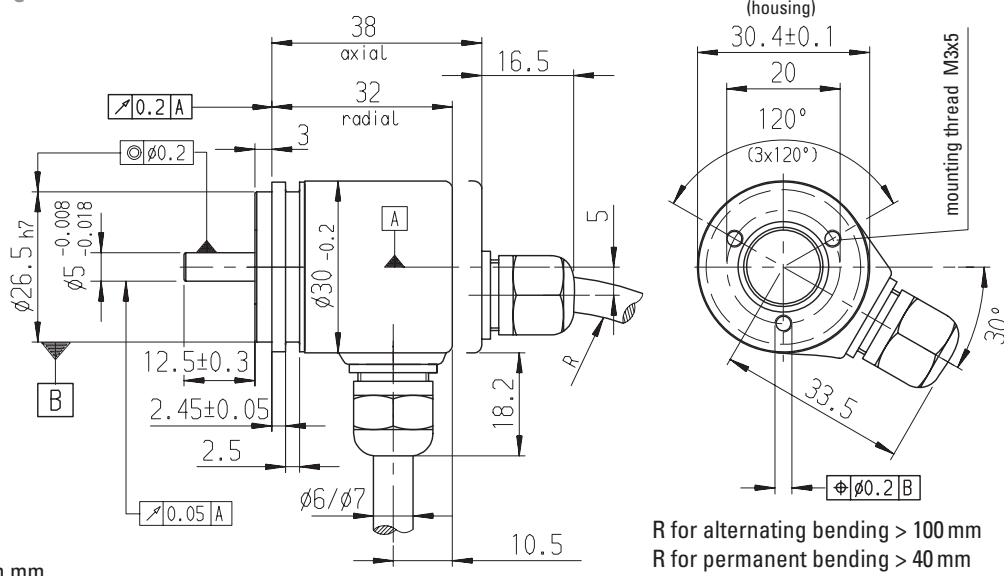

Pilot flange, cable

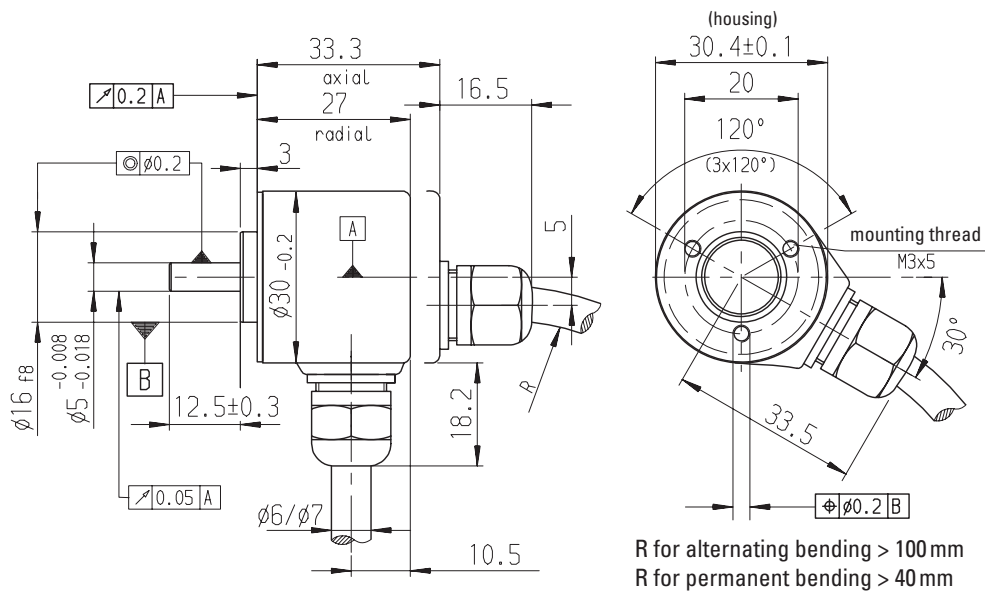

Incremental Shaft Encoders Industrial types

Type RI 30 Solid shaft

Synchro flange, BINDER

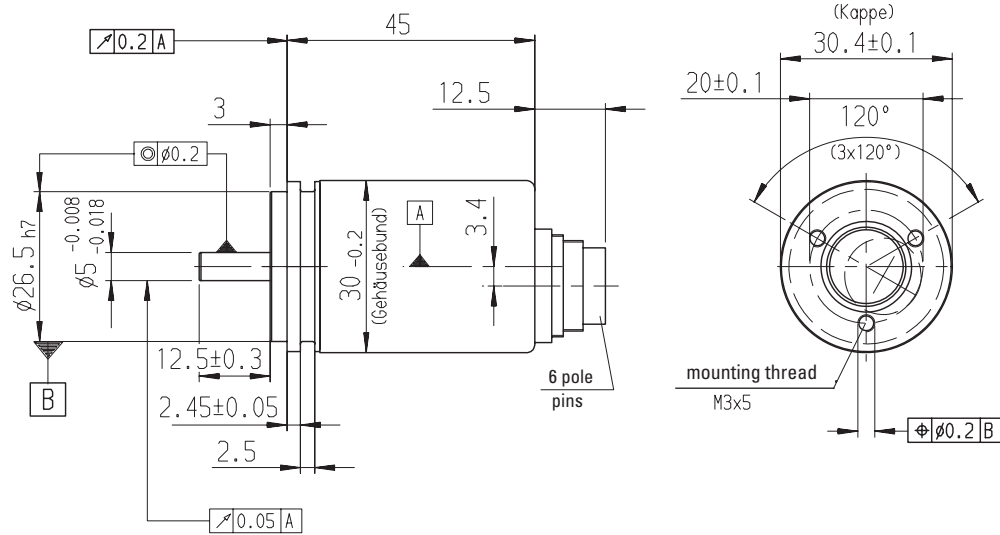

Dimensions in mm

Pilot flange, BINDER

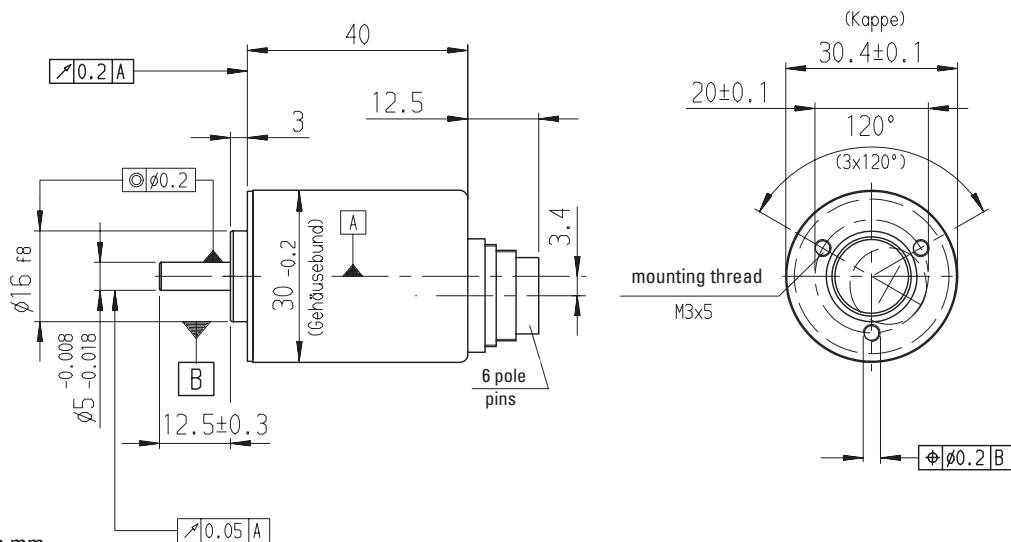

Dimensions in mm

Incremental Shaft Encoders

Type RI 30

Industrial types

Solid shaft

CONNECTOR 6 POLE (BINDER)

Description (push-pull)	Pin
DC 10 - 30 V	1
Channel A	2
Channel N	3
Channel B	4
Alarm	5
GND	6

PIN ASSIGNMENT Cable

Description (push-pull)	Description (RS 422)	Lead Ø mm ²	Colour
DC 10 - 30 VDC	DC 5 V	0.5	red
	Sense V _{CC}	0.14	yellow/red
Channel A	Channel A	0.14	white
	Channel \bar{A}	0.14	white/brown
Channel B	Channel B	0.14	green
	Channel \bar{B}	0.14	green/brown
Channel N	Channel N	0.14	yellow
	Channel \bar{N}	0.14	yellow/brown
GND	GND	0.5	black
Alarm	Alarm /Sense GND ¹	0.14	yellow/black
screen ²	screen ²		screen ²

¹ depending on ordering code

² connected with encoder housing

ORDERING INFORMATION

Type	Model	Number of pulses	Supply voltage	Flange, Protection, Shaft	Output	Connection
<input type="checkbox"/>	<input type="checkbox"/>	<input type="text"/>	<input type="checkbox"/>	<input type="text"/>	<input type="checkbox"/>	<input type="checkbox"/>
RI30-	O Standard	5 ... 1 500	A DC 5 V E DC 10 - 30 V (only with push-pull)	S.34 Synchro, IP64, 5 mm R.34 Pilot, IP64, 5 mm	T RS422 + Sense K push-pull short circuit proof R RS422 + Alarm	A Cable axial B Cable radial N BINDER ¹ 6 pole, axial (only push-pull)
¹ encoder connector with pins						

Industrial types

Solid shaft



NUMBER OF PULSES

- Miniature industry standard encoder for high numbers of pulses
- High reliability
- Application e.g.:
 - CNC axles
 - Machine tools
 - Robots
 - Special purpose machines
 - High-speed winding machines

5 / 10 / 20 / 25 / 28 / 32 / 50 / 60 / 72 / 100 / 128 / 144 / 200 / 250 / 256 / 288 / 300 / 360 / 400 / 500 / 512 / 600 / 720 / 900 / 1000 / 1024 / 1250 / 1500 / 2000 / 2048 / 2500 / 3000 / 3600
 Other number of pulses on request

TECHNICAL DATA mechanical

Shaft diameter	6 mm / 6.35 mm
Absolute max. shaft load	radial 10 N, axial 5 N
Absolute max. speed	max. 10 000 min ⁻¹
Torque	≤ 0.3 Ncm
Moment of inertia	approx. 2.8 gcm ²
Protection class (EN 60529)	Housing IP64, bearings IP64
Operating temperature	-10 ... +70 °C
Storage temperature	-25 ... +85 °C
Vibration resistance	100 m/s ² (10 ... 2000 Hz)
Shock resistance	1 000 m/s ² (6 ms)
Connection	1.5 m cable ¹ or connector, axial or radial
Housing	Aluminium
Flange	S = synchro flange, R = pilot flange
Weight	approx. 80 g

¹ Other cable length on request

TECHNICAL DATA electrical

General design	as per DIN VDE 0160, protection class III, contamination level 2, overvoltage class II	
Supply voltage (SELV)	with RS 422 (R, T):	DC 5 V ± 10 %
	with push-pull (K, I):	DC 10 - 30 V ²
Max. current w/o load	40 mA (DC 5 V), 60 mA (DC 10 V), 30 mA (DC 24 V)	
Standard output versions ³	RS 422 (R):	A, B, N, \overline{A} , \overline{B} , \overline{N} , \overline{Alarm}
	RS 422 (T):	A, B, N, \overline{A} , \overline{B} , \overline{N} , Sense
	push-pull (K):	A, B, N, \overline{Alarm}
	push-pull complementary (I):	A, B, N, \overline{A} , \overline{B} , \overline{N} , \overline{Alarm}

² Pole protection

³ Output description and technical data see chapter "Technical basics"

Incremental Shaft Encoders Industrial types

Type RI 36 Solid shaft

DIMENSIONAL DRAWINGS

Synchro flange

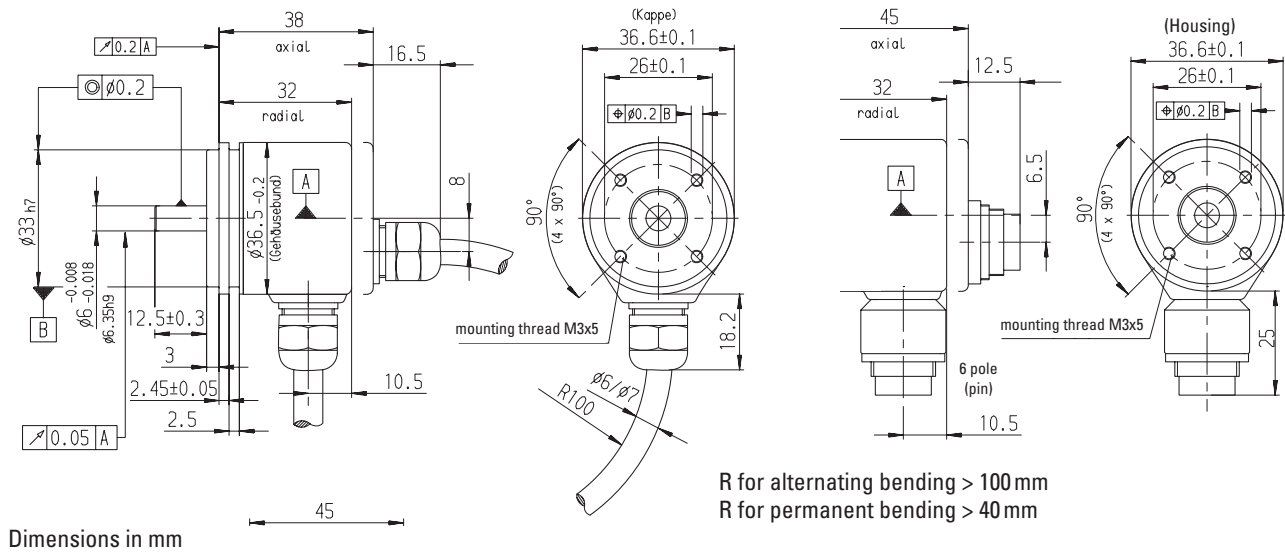

Pilot flange

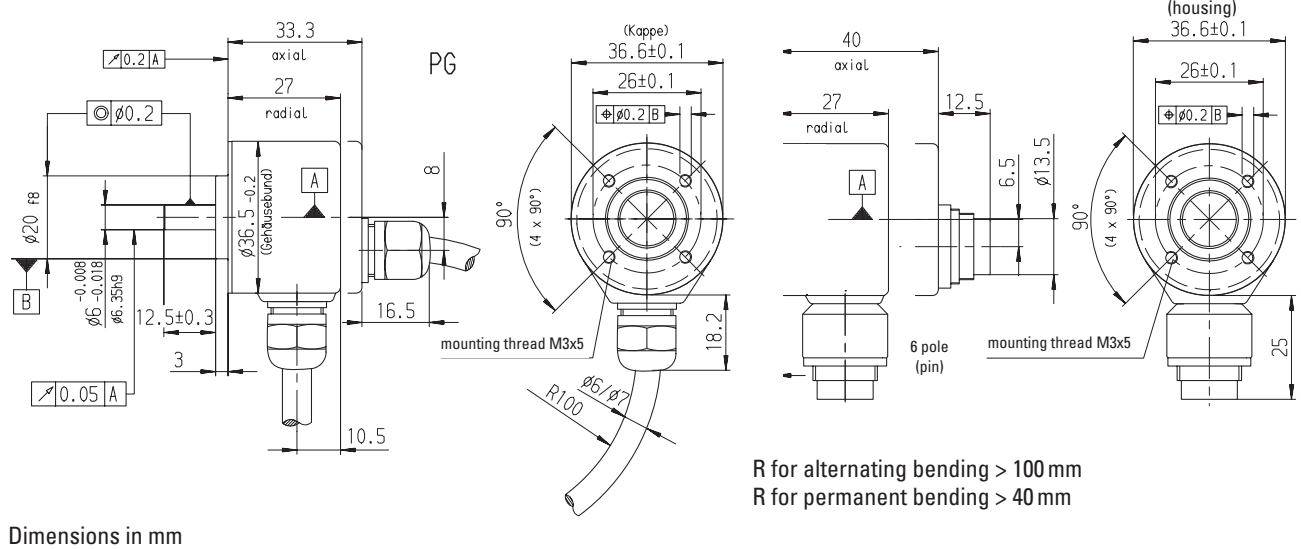

CONNECTOR 6 POLE (BINDER)

Description (push-pull)	Pin
DC 10 - 30 V	1
Channel A	2
Channel N	3
Channel B	4
Alarm	5
GND	6

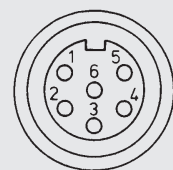

PIN ASSIGNMENT

Cable PVC (A, B)		Output		
Colour	Lead mm ²	RS 422 (R, T)	push-pull (K)	push-pull complementary (I)
red	0.5	DC 5 V	DC 10 - 30 V	DC 10 - 30 V
yellow/red	0.14	Sense V _{CC}		Sense V _{CC}
white	0.14	Channel A	Channel A	Channel A
white/brown	0.14	Channel \bar{A}		Channel \bar{A}
green	0.14	Channel B	Channel B	Channel B
green/brown	0.14	Channel \bar{B}		Channel \bar{B}
yellow	0.14	Channel N	Channel N	Channel N
yellow/brown	0.14	Channel \bar{N}		Channel \bar{N}
black	0.5	GND	GND	GND
yellow/black	0.14	Alarm/Sense GND ¹	Alarm	Alarm
screen ²		screen ²	screen ²	screen ²

¹ depending on ordering code

² connected with encoder housing

ORDERING INFORMATION

Type	Model	Number of pulses	Supply voltage	Flange, Protection, Shaft	Output	Connection
<input type="text"/>	<input type="text"/>	<input type="text"/>	<input type="text"/>	<input type="text"/>	<input type="text"/>	<input type="text"/>
RI36-	O Standard	5 ... 3 600	A DC 5 V E DC 10 - 30 V (only with push-pull)	S.31 Synchro, IP64, 6 mm S.35 Synchro, IP64, 6.35 mm R.31 Pilot, IP64, 6 mm R.35 Pilot, IP64, 6.35 mm	T RS422 + Sense K push-pull short circuit proof R RS422 + Alarm I push-pull complementary	A Cable axial B Cable radial N BINDER ³ 6 pole, axial (only push-pull) J BINDER ³ , 6 pole, radial (only push-pull)

³ encoder connector with pins

Industrial types

Solid shaft



Synchro flange



Clamping flange

- Universal industry standard encoder
- Up to 40 000 steps with 10 000 pulses
- High signal accuracy
- Protection class up to IP67
- Operating temperature up to 100 °C (RI 58-T)
- Flexible due to many flange and configuration variants
- Suitable for high shock ratings
- Application e.g.: Machine tools, CNC axles, packing machines, motors/drives, injection moulding machines, sawing machines, textile machines
- For EX version, see RX 70-I

NUMBER OF PULSES

RI 58-O 1 / 2 / 3 / 4 / 5 / 10 / 15 / 20 / 25 / 30 / 35 / 40 / 45 / 50 / 60 / 64 / 70 / 72 / 80 / **100** / 125 / 128 / 144 / 150 / 180 / 200 / 230 / **250** / 256 / 300 / 314 / 350 / 360 / 375 / 400 / 460 / 480 / **500** / 512 / 600 / 625 / 635 / 720 / 750 / 900 / **1000** / **1024** / 1200 / **1250** / 1500 / 1600 / 1800 / 2000 / 2048 / **2500** / 3000 / 3480 / **3600** / 3750 / 3968 / 4000 / **4096** / 4800 / **5000** / 5400 / 6000 / 7200 / 7680 / 8000 / 8192 / 9000 / 10000
 Other number of pulses on request
 Preferably available versions are printed in bold type.

RI 58-T (high temperature) as above, but only for the range from 4 ... 2500 pulses
 Other number of pulses on request

TECHNICAL DATA mechanical

Shaft diameter	6 mm / 6.35 mm / 7 mm / 12 mm / 10 mm / 9.52 mm	
Absolute max. shaft load	Ø 12 mm	radial 80 N/axial 60 N
	Ø 7...10 mm	radial 60 N/axial 40 N
	Ø 6 mm / 6.35 mm	radial 40 N/axial 20 N
Absolute max. speed	10 000 min ⁻¹	
Torque	≤ 0.5 Ncm, ≤ 1 Ncm (IP67)	
Moment of inertia	Synchro flange approx. 14 gcm ² Clamping flange approx. 20 gcm ²	
Protection class (EN 60529)	Housing IP65, bearings IP64 Housing IP67, bearings IP67	
Operating temperature	RI 58-O: -10 ... +70 °C; RI 58-T: -25 ... +100 °C	
Storage temperature	RI 58-O: -25 ... +85 °C; RI 58-T: -25 ... +100 °C	
Vibration resistance (IEC 68-2-6)	100 m/s ² (10 ... 2000 Hz)	
Shock resistance (IEC 68-2-27)	1 000 m/s ² (6 ms)	
Connection	1.5 m cable ¹ or connector, axial oder radial	
Housing	Aluminium Ø 58 mm	
Flange	S = synchro flange, K = clamping flange, G, Q = square flange, M = synchro clamping flange	
Weight	approx. 360 g	

¹ Other cable length on request

Industrial types

Solid shaft

TECHNICAL DATA electrical

General design	as per DIN VDE 0160, protection class III, Contamination level 2, over voltage level II		
Supply voltage (SELV)	with RS 422 + Sense (T): DC 5V ± 10 % with RS 422 + Alarm (R): DC 5V ± 10 % oder DC 10 - 30 V ¹ with push-pull (K, I): DC 10 - 30V ¹		
Max. current w/o load	40 mA (DC 5V), 60 mA (DC 10V), 30 mA (DC 24V)		
Standard output versions ²	RS 422 (R):	A, B, N, \bar{A} , \bar{B} , \bar{N} , \bar{Alarm}	
	RS 422 (T):	A, B, N, \bar{A} , \bar{B} , \bar{N} , Sense	
	push-pull (K):	A, B, N, \bar{Alarm}	
	push-pull complementary (I):	A, B, N, \bar{A} , \bar{B} , \bar{N} , \bar{Alarm}	

¹ Pole protection with supply voltage DC 10-30 V

² Output description and technical data see chapter "Technical basics"

PIN ASSIGNMENT Cable PVC

Cable PVC (A, B) Colour	Output RS 422 (R, T)	push-pull (K)	push-pull complementary (I)
red	DC 5/10 - 30 V	DC 10 - 30 V	DC 10 - 30 V
yellow/red	Sense V _{CC}		Sense V _{CC}
white	Channel A	Channel A	Channel A
white/brown	Channel \bar{A}		Channel \bar{A}
green	Channel B	Channel B	Channel B
green/brown	Channel \bar{B}		Channel \bar{B}
yellow	Channel N	Channel N	Channel N
yellow/brown	Channel \bar{N}		Channel \bar{N}
black	GND	GND	GND
yellow/black	\bar{Alarm} /Sense GND ¹	\bar{Alarm}	\bar{Alarm}
screen ²	screen ²	screen ²	screen ²

¹ depending on ordering code

² connected with encoder housing

PIN ASSIGNMENT Cable TPE

Cable TPE (E, F) Colour	Output RS 422 (R, T)	push-pull (K)	push-pull complementary (I)
brown/green	DC 5/10 - 30 V	DC 10 - 30 V	DC 10 - 30 V
blue	Sense V _{CC}		Sense V _{CC}
brown	Channel A	Channel A	Channel A
green	Channel \bar{A}		Channel \bar{A}
grey	Channel B	Channel B	Channel B
pink	Channel \bar{B}		Channel \bar{B}
red	Channel N	Channel N	Channel N
black	Channel \bar{N}		Channel \bar{N}
white/green	GND	GND	GND
violet (white) ¹	\bar{Alarm} /Sense GND ²	\bar{Alarm}	\bar{Alarm}
screen ³	screen ³	screen ³	screen ³

¹ white with RS 422 + Sense (T)



² depending on ordering code

³ connected with encoder housing

Industrial types

Solid shaft

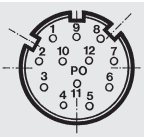
CONNECTOR 12 POLE (CONIN)

Pin	RS 422 + Sense (T)	RS 422 + Alarm (R)	push-pull (K)	push-pull complementary (I)	
1	Channel \bar{B}	Channel \bar{B}	N.C.	Channel \bar{B}	 Pin assignment connector counter clockwise (CCW)
2	Sense V_{CC}	Sense V_{CC}	N.C.	Sense V_{CC}	
3	Channel N	Channel N	Channel N	Channel N	
4	Channel \bar{N}	Channel \bar{N}	N.C.	Channel \bar{N}	
5	Channel A	Channel A	Channel A	Channel A	
6	Channel \bar{A}	Channel \bar{A}	N.C.	Channel \bar{A}	
7	N.C.	Alarm	Alarm	Alarm	 connector clockwise (cw)
8	Channel B	Channel B	Channel B	Channel B	
9	N.C. ¹	N.C. ¹	N.C. ¹	N.C. ¹	
10	GND	GND	GND	GND	
11	Sense GND	N.C.	N.C.	N.C.	
12	DC 5 V	DC 5/10 - 30 V	DC 10 - 30 V	DC 10 - 30 V	

¹ screen for cable with CONIN connector

CONNECTOR 10 POLE (MIL)

Pin	Description RS 422/Euro-pinout (Connection codes O and K)	push-pull	push-pull complementary
1/A	Channel A	Channel A	Channel A
2/B	Channel B	Channel B	Channel B
3/C	Channel N	Channel N	Channel N
4/D	DC 5/10 - 30 V	DC 10 - 30 V	DC 10 - 30 V
5/E	Alarm	Alarm	Alarm
6/F	GND	GND	GND
7/G	Channel \bar{A}	screen	Channel \bar{A}
8/H	Channel \bar{B}	N.C.	Channel \bar{B}
9/I	Channel \bar{N}	N.C.	Channel \bar{N}
10/J	screen	screen	screen

CONNECTOR 6 POLE (BINDER)

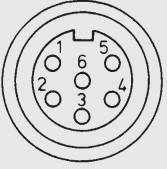
Description (push-pull)	Pin (Stifte)	
DC 10 - 30 V	1	
Channel A	2	
Channel N	3	
Channel B	4	
Alarm	5	
GND	6	

Incremental Shaft Encoders Industrial types

Type RI 58 Solid shaft

DIMENSIONAL DRAWINGS

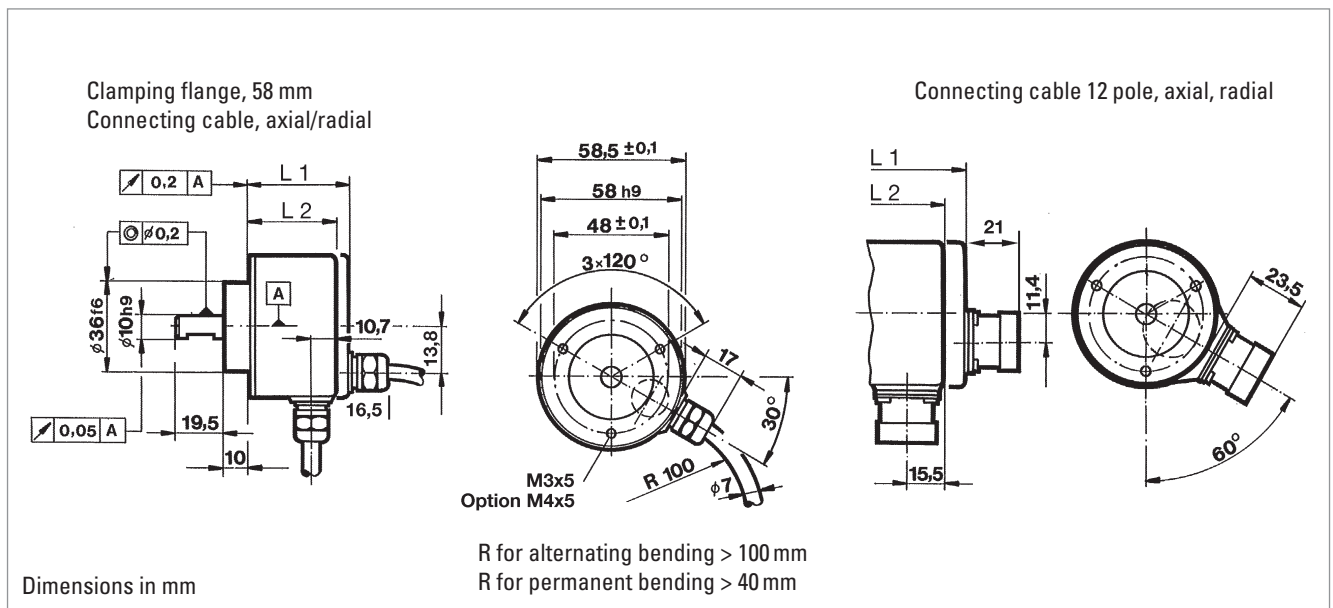
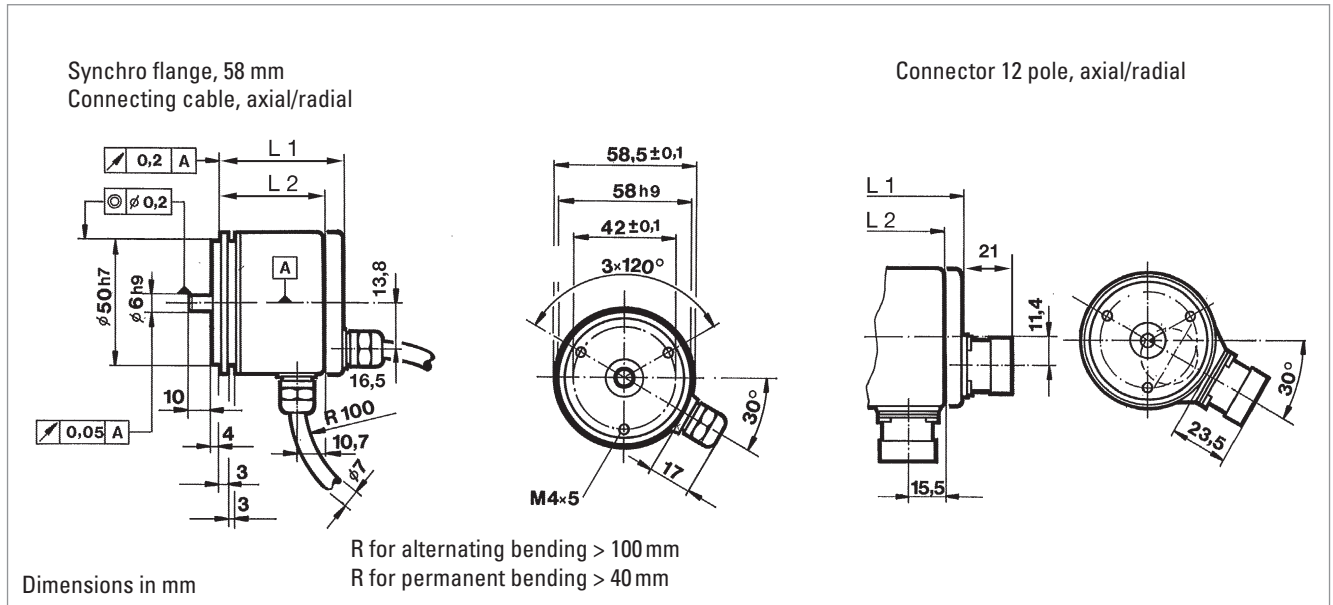

DIMENSIONS

Typ	Connection	Output	axial L1 mm	radial L2 mm
Synchro flange, 58 mm	cable	R (with $U_B = DC 5 V$), T, K, I	51.5	41.5
		R (with $U_B = DC 10 - 30 V$)	56	56
	connector	R (with $U_B = DC 5 V$), T, K, I	57.5	51.5
		R (with $U_B = DC 10 - 30 V$)	57.5	56
Clamping flange, 58 mm	cable	R (with $U_B = DC 5 V$), T, K, I	45.5	35.5
		R (with $U_B = DC 10 - 30 V$)	50	50
	connector	R (with $U_B = DC 5 V$), T, K, I	51.5	45.5
		R (with $U_B = DC 10 - 30 V$)	51.5	50

Incremental Shaft Encoders Industrial types

Type RI 58 Solid shaft

DIMENSIONAL DRAWINGS

**Synchro clamping flange,
63.5 mm (2.5")**

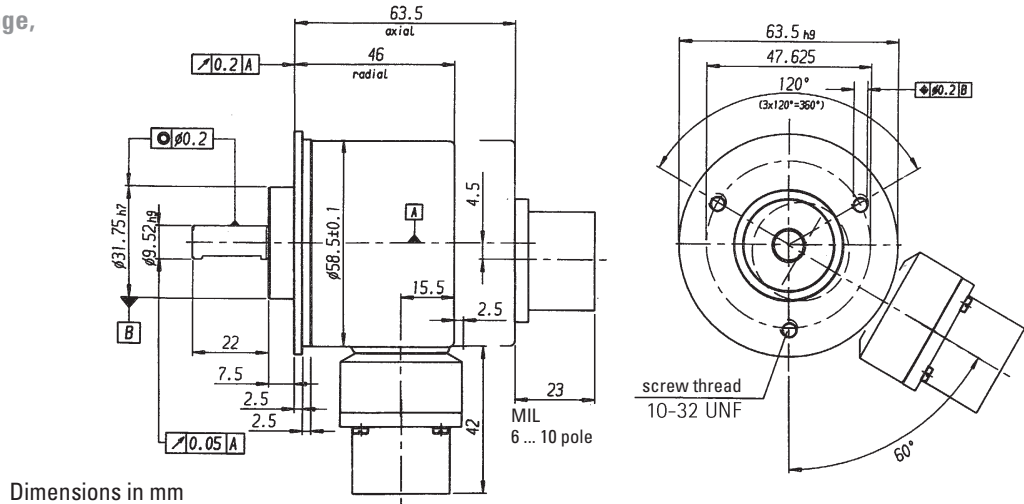

**Square flange,
63.5 x 63.5 mm (2.5" x 2.5")**

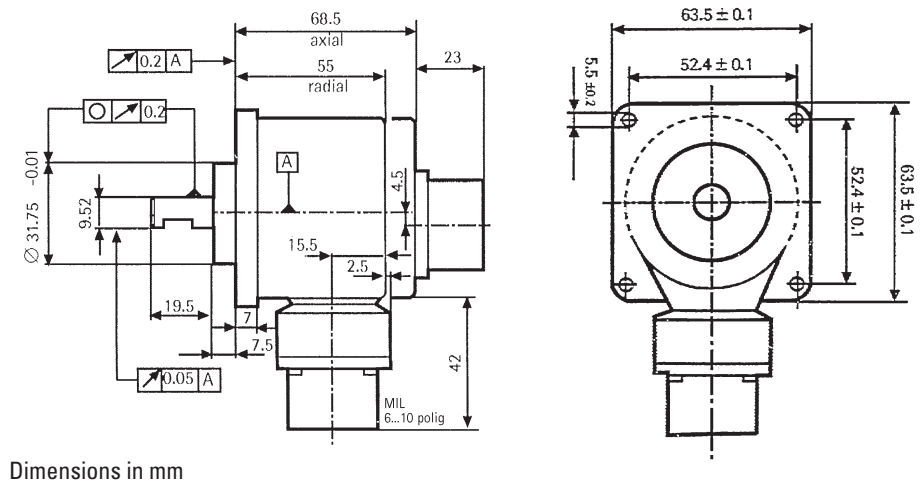

Square flange, 80 x 80 mm

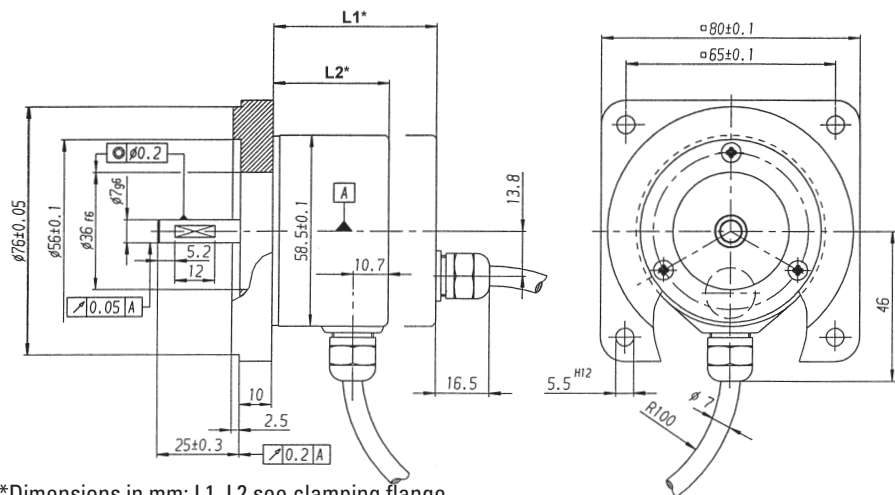

Incremental Shaft Encoders

Guide for selection

Type RI 58

Solid shaft

STANDARD VERSIONS

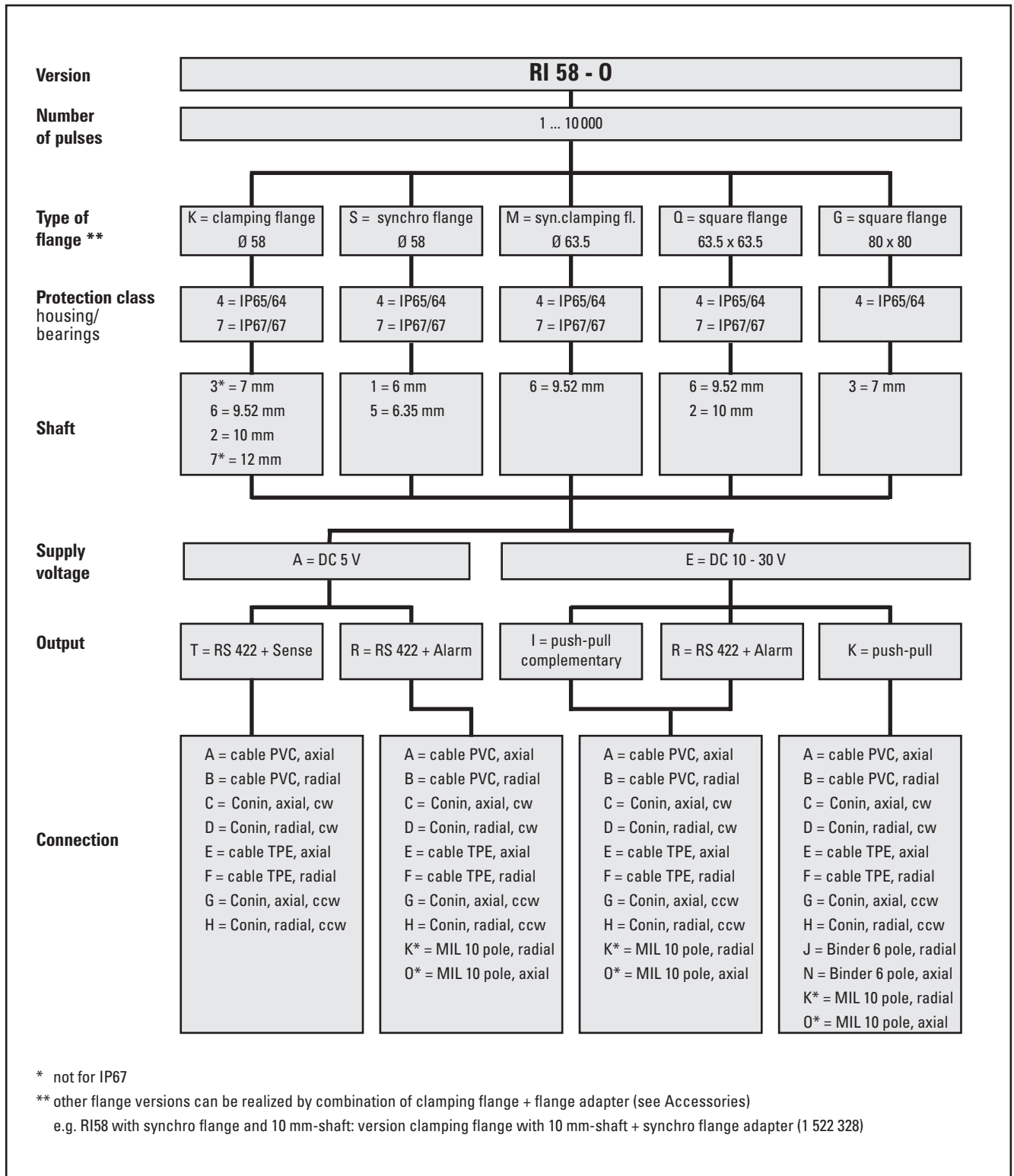

Incremental Shaft Encoders

Guide for selection

Type RI 58

Solid shaft

STANDARD VERSIONS
100 °C max. operation temperature

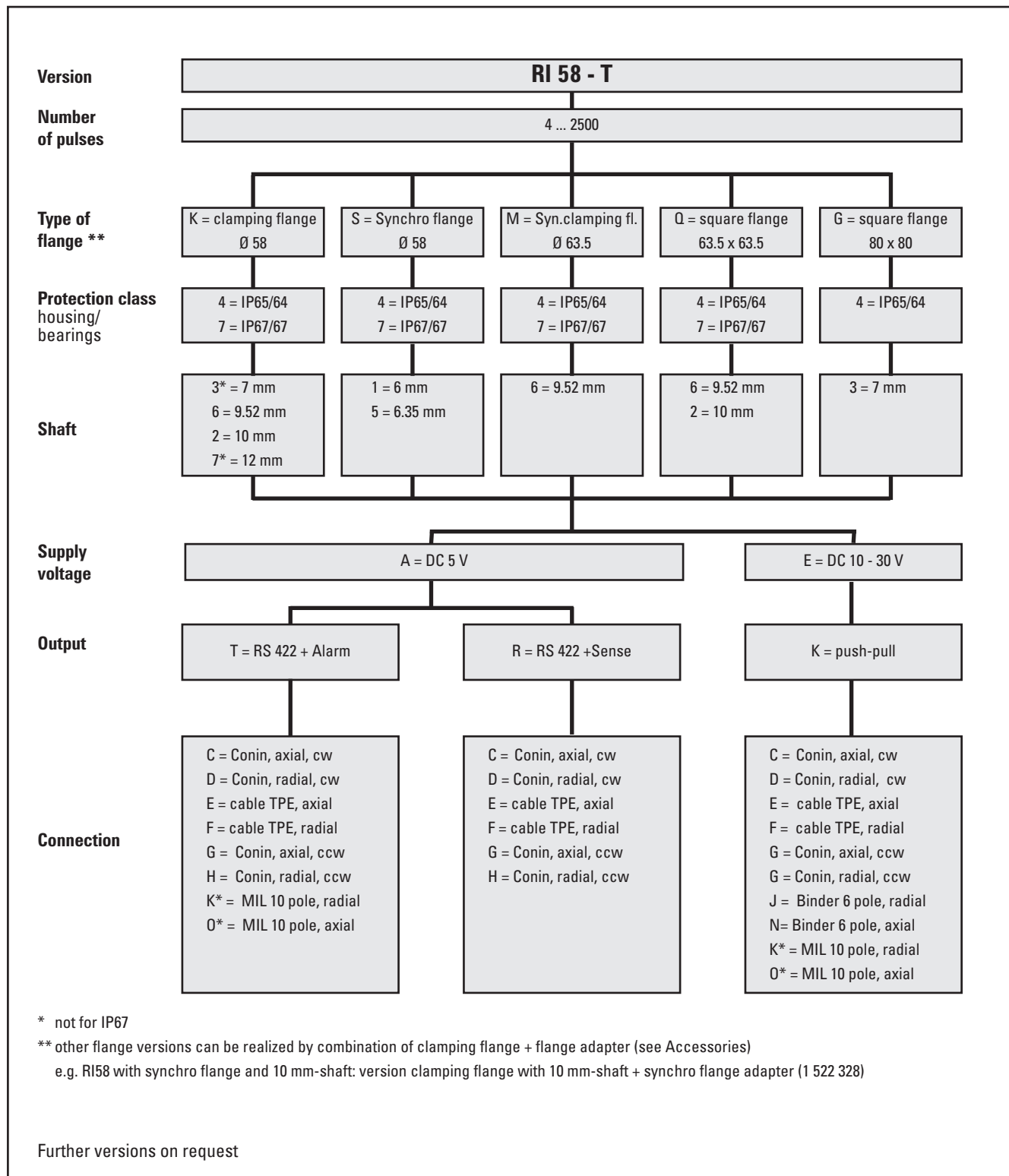

Incremental Shaft Encoders

Industrial types

Type RI 58

Solid shaft

ORDERING INFORMATION

Please check „selection guide“ on previous pages as not all combinations are possible!

Type	Model	Number of pulses	Supply voltage	Flange, Protection ¹ , Shaft ²	Output	Connection
<input type="checkbox"/>	<input type="checkbox"/>	<input type="checkbox"/>	<input type="checkbox"/>	<input type="checkbox"/>	<input type="checkbox"/>	<input type="checkbox"/>
RI58-	O Standard T High temperature	RI58-O: 1 ... 10 000 RI58-T: 4 ... 2 500	A DC 5 V E DC 10-30 V (only with push-pull)	K.43 Clamping Ø58, IP65/64, 7 mm K.46 Clamping Ø58, IP65/64, 9.52 mm K.42 Clamping Ø58, IP65/64, 10 mm K.47 Clamping Ø58, IP65/64, 12 mm K.76 Clamping Ø58, IP67/67, 9.52 mm K.72 Clamping Ø58, IP67/67, 10 mm S.41 Synchro Ø58, IP65/64, 6 mm S.45 Synchro Ø58, IP65/64, 6.35 mm S.71 Synchro Ø58, IP67/67, 6 mm S.75 Synchro Ø58, IP67/67, 6.35 mm M.46 Syn.clamping Ø63.5, IP65/64, 9.52 mm M.76 Syn.clamping Ø63.5, IP67/67, 9.52 mm Q.46 Square 63.5 x 63.5, IP65/64, 9.52 mm Q.42 Square 63.5 x 63.5, IP65/64, 10 mm Q.76 Square 63.5 x 63.5, IP67/67, 9.52 mm Q.72 Square 63.5 x 63.5, IP67/67, 10 mm G.43 Square 80 x 80, IP67/67, 7 mm	T RS 422 + Sense K push-pull, short circuit proof I push-pull complementary R RS 422 + Alarm	A PVC cable, axial B PVC cable, radial C CONIN ³ , axial, cw D CONIN ³ , radial, cw E TPE cable, axial F TPE cable, radial G CONIN ³ , axial, ccw H CONIN ³ , radial, ccw J BINDER ³ , 6 pole, radial N BINDER ³ , 6 pole, axial O MIL MS ³ , 10 pole, axial K MIL MS ³ , 10 pole, radial

¹ Housing/ bearings

² other flange versions can be realized by combination of clamping flange + flange adapter (see Accessories)
e.g. RI58 with synchro flange and 10 mm-shaft: version clamping flange with 10 mm-shaft + synchro flange adapter (1 522 328)

³ encoder connector with pins

ACCESSORIES

Clamping eccentric (set of three)

Ordering code 0 070 655

Spring washer coupling
hole 6/6 mm

Ordering code 3 520 081

hole 10/10 mm

Ordering code 3 520 088

Cable plug connector
for connector (CONIN),
cw (type of connection C, D)

Ordering code 3 539 202

for connector (CONIN),
ccw (type of connection G, H)

Ordering code 3 539 229

Mounting spanner
for CONIN connectors

Ordering code 3 539 343

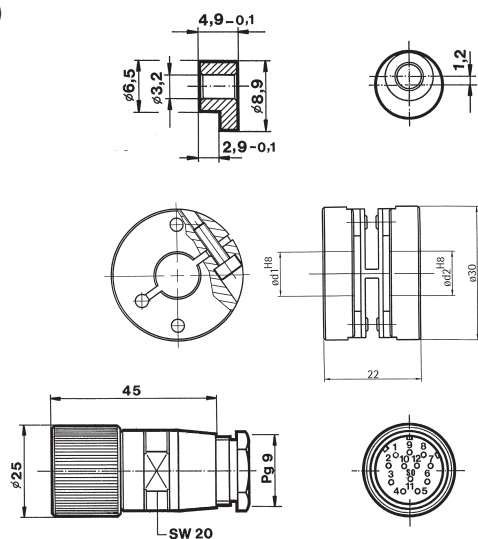

Extension cables
(TPE)

12 pole plug (socket) on one end

L = 3 m

L = 5 m

L = 10 m

TPE cable (not made up with connectors) **3 280 112** + state required length

For more detailed specifications and other accessories see chapter "Accessories"

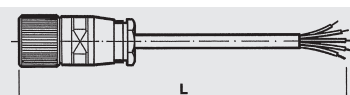

clockwise (C,D)

Ordering code

1 522 348

1 522 349

1 522 350

counter clockwise (G,H)

Ordering code

1 522 394

1 522 395

1 522 396

Industrial types

Hollow shaft



- miniature industry encoder for high number of pulses
- short mounting length
- easy mounting procedure
- Application e.g.:
 - Motors
 - Machine tools
 - Packaging Machines
 - Robots
 - Automated SMD equipment

NUMBER OF PULSES

5 / 10 / 20 / 25 / 50 / 60 / 100 / 200 / 250 / 300 / 360 / 500 / 600 / 720 / 1000 / 1024 / 1250 / 1500 / 2000 / 2048 / 2500 / 3000 / 3600
 Other number of pulses on request

TECHNICAL DATA mechanical

Mounting	Clamping shaft (one side open) with clamping ring front
Coupling	Hubshaft with tether
Shaft diameter	4, 6, 8, 10 mm hollow shaft
Angular shaft misalignment max.	±0.15 mm radial, ±0.5 mm axial
Absolute max. speed	max. 10 000 min ⁻¹
Torque	≤ 1 Ncm
Moment of inertia	approx. 3 gcm ²
Protection class (EN 60529)	Housing IP64, bearings IP64
Operating temperature	-10 ... +70 °C
Storage temperature	-25 ... +85 °C
Vibration resistance	100 m/s ² (10 ... 2000 Hz)
Shock resistance	1000 m/s ² (6 ms)
Connection	1.5 m cable ¹ axial or radial
Housing	Aluminium
Weight	approx. 80 g

¹ Other cable length on request

TECHNICAL DATA electrical

General design	as per DIN VDE 0160, protection class III, contamination level 2, overvoltage class II	
Supply voltage (SELV)	with RS 422 (R, T):	DC 5 V ± 10 %
	with push-pull (K, I):	DC 10 - 30 V ²
Max. current w/o load	40 mA (DC 5 V), 60 mA (DC 10 V), 30 mA (DC 24 V)	
Standard output versions ³	RS 422 (R):	A, B, N, \overline{A} , \overline{B} , \overline{N} , \overline{Alarm}
	RS 422 (T):	A, B, N, \overline{A} , \overline{B} , \overline{N} , Sense
	push-pull (K):	A, B, N, \overline{Alarm}
	push-pull complementary (I):	A, B, N, \overline{A} , \overline{B} , \overline{N} , \overline{Alarm}

² Pole protection

³ Output description and technical data see chapter "Technical basics"

Incremental Shaft Encoders Industrial types

Type RI 36-H Hollow shaft

DIMENSIONAL DRAWINGS

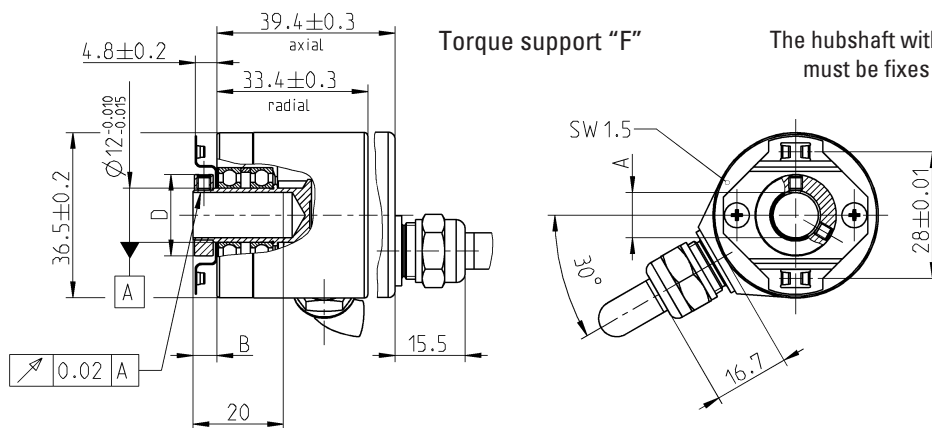
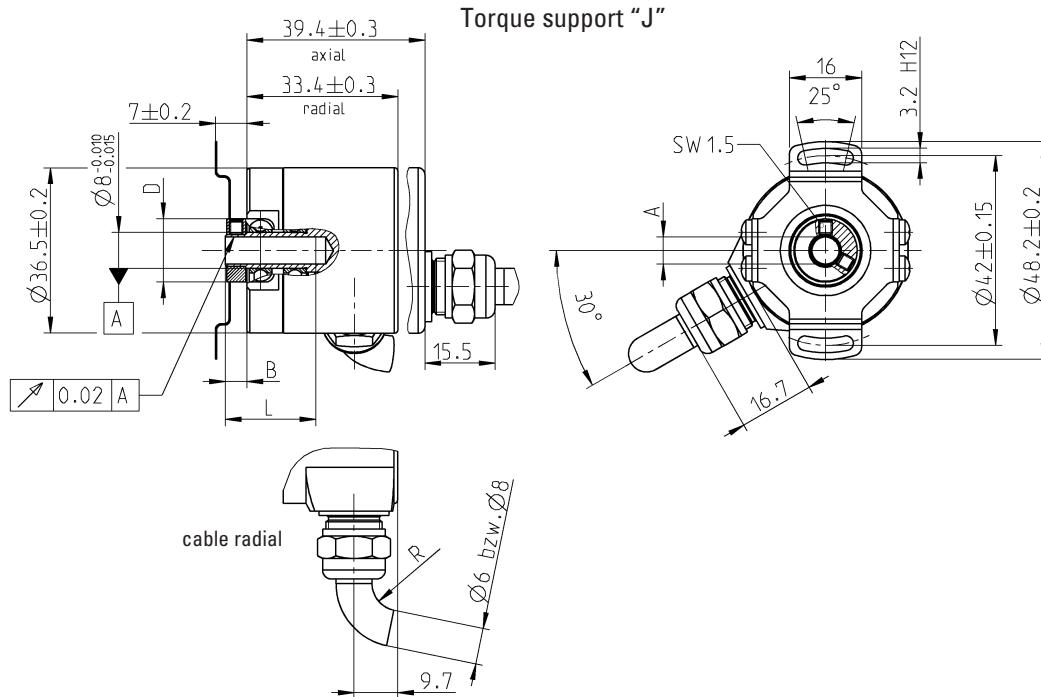

Dim.:	Hollow shaft Ø				Unit
A	4 +0.01	6 +0.01	8 +0.01	10 +0.01	mm
A*	4 g7	10 g7	8 g7	10 g7	mm
B	4.8±0.2	4.8±0.2	5.3±0.2	5.3±0.2	mm
D	12	14	16	18	mm
L min	6	9	12	15	mm
L max	20	20	20	20	mm

A* = diameter of connection shaft
 B = space between housing and shaft
 D = Ø clamping ring
 L = length of connection shaft

R for alternating bending ≥ 100 mm
 R for permanent bending ≤ 40 mm

Tightening torque of set screw 15 Ncm

Dimensions in mm

PIN ASSIGNMENT

Cable PVC (A, B)		Output		
Colour	Litze mm ²	RS 422 (R, T)	push-pull (K)	push-pull complementary (I)
red	0.5	DC 5 V	DC 10 - 30 V	DC 10 - 30 V
yellow/red	0.14	Sense V _{CC}		Sense V _{CC}
white	0.14	Channel A	Channel A	Channel A
white/brown	0.14	Channel \bar{A}		Channel \bar{A}
green	0.14	Channel B	Channel B	Channel B
green/brown	0.14	Channel \bar{B}		Channel \bar{B}
yellow	0.14	Channel N	Channel N	Channel N
yellow/brown	0.14	Channel \bar{N}		Channel \bar{N}
black	0.5	GND	GND	GND
yellow/black	0.14	Alarm / Sense GND ¹	Alarm	Alarm
screen ²		screen ²	screen ²	screen ²

¹ depending on ordering code

² connected with encoder housing

ORDERING INFORMATION

Type	Model	Number of pulses	Supply voltage	Flange, Protection, Shaft	Output	Connection
<input type="checkbox"/>	<input type="checkbox"/>	<input type="text"/>	<input type="checkbox"/>	<input type="text"/>	<input type="checkbox"/>	<input type="checkbox"/>
RI36-	H Hollow shaft	5 ... 3 600	A DC 5 V E DC 10 - 30 V (only with push-pull)	F.30 Clamping, IP64, 4 mm * F.31 Clamping, IP64, 6 mm * F.3C Clamping, IP64, 8 mm * F.32 Clamping, IP64, 10 mm * J.30 Clamping, IP64, 4 mm ** J.31 Clamping, IP64, 6 mm ** J.3C Clamping, IP64, 8 mm ** J.32 Clamping, IP64, 10 mm **	T RS 422 + Sense K push-pull short circuit proof R RS 422 + Alarm I push-pull complementary	A Cable axial B Cable radial
<p>* Fixing of hubshaft with tether by cylindrical pin ** Fixing of hubshaft with tether by oblong hole</p>						

Industrial types

Hollow shaft



- Through shaft
- High accuracy by means of integrated flexible coupling
- Safe shaft mounting
- Application e.g.:
 - textile machines
 - motors
 - drives
 - copiers

NUMBER OF PULSES

1 / 2 / 3 / 4 / 5 / 10 / 15 / 20 / 25 / 30 / 35 / 40 / 45 / 50 / 60 / 64 / 70 / 72 / 80 / **100** / 125 / 128 / 144 / 150 / 180 / 200 / **250** / 256 / 300 / 314 / 350 / 360 / 375 / 400 / 460 / 480 / **500** / 512 / 600 / 625 / 720 / 900 / **1000** / **1024** / **1250** / 1500 / 1600 / 1800 / 2000 / 2048 / **2500** / 3000 / 3480 / **3600** / 4000 / **4096** / **5000**

Other number of pulses on request

Preferably available versions are printed in bold type.

TECHNICAL DATA
mechanical

Shaft diameter	10 mm hollow shaft 12 mm hollow shaft
Required dimension of mounting shaft	Ø 10 mm, tolerance g8 (-0.005 ... -0.027 mm) Ø 12 mm, tolerance g8 (-0.006 ... -0.033 mm)
Balance tolerances	
Misalignment axial	± 0.4 mm
Misalignment parallel	0.4 mm
Misalignment angular	1°
Absolute max. speed	max. 3000 min ⁻¹
Torque	≤ Ncm (IP64)
Moment of inertia	approx. 65 gcm ² (10 mm shaft) approx. 95 gcm ² (12 mm shaft)
Protection class (EN 60529)	Housing IP64, bearings IP64
Operating temperature an Welle	-10 ... +70 °C
Storage temperature	-25 ... +85 °C
Vibration resistance (IEC 68-2-6)	10 g = 100 m/s ² (10 ... 2 kHz)
Shock resistance (IEC 68-2-27)	100 g = 1000 m/s ² (6 ms)
Connection	Cable radial, 1.5 m ¹
Housing	Aluminium
Flange	Synchro flange
Weight	approx. 210 g

¹ Other cable length on request

Incremental Shaft Encoders Type RI 58-H

Industrial types Hollow shaft

TECHNICAL DATA electrical

General design	as per DIN VDE 0160, protection class III, contamination level 2, overvoltage class II	
Supply voltage	with RS 422 + Sense (T): DC 5 V ± 10 % with RS 422 + Alarm (R): DC 5 V ± 10 % oder DC 10 - 30 V ¹ with push-pull (K, I): DC 10 - 30 V ¹	
Max. current w/o load	40 mA (DC 5 V), 60 mA (DC 10 V), 30 mA (DC 24 V)	
Standard output versions ²	RS 422 (R):	A, B, N, \bar{A} , \bar{B} , \bar{N} , Alarm
	RS 422 (T):	A, B, N, \bar{A} , \bar{B} , \bar{N} , Sense
	push-pull (K):	A, B, N, Alarm
	push-pull complementary (I):	A, B, N, \bar{A} , \bar{B} , \bar{N} , Alarm

¹ Pole protection with supply voltage DC 10 - 30 V

² Output description and technical data see chapter "Technical basics"

DIMENSIONAL DRAWINGS

Synchro flange

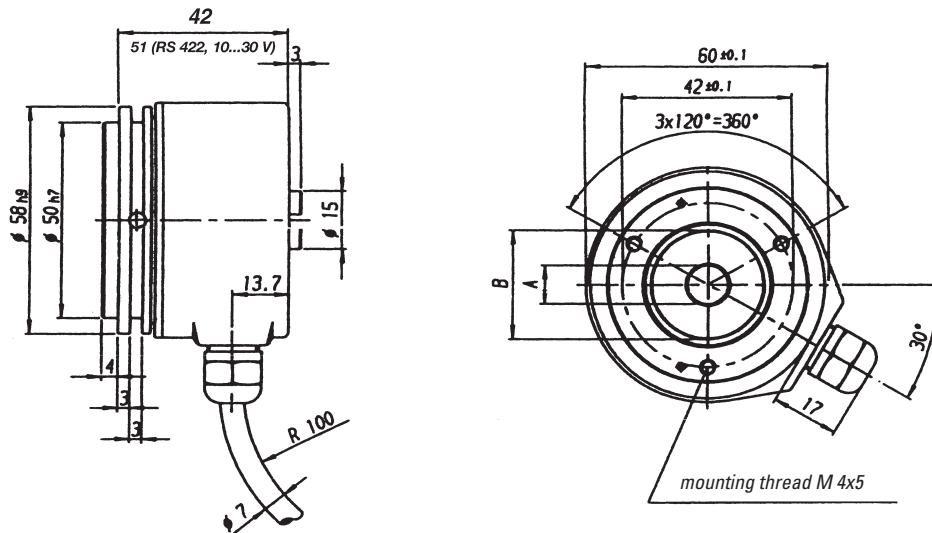

R for alternating bending > 100 mm
R for permanent bending > 40 mm

∅ Hollow shaft	Required dimension of mounting shaft (g8)
10 mm	-0.005 ... -0.027 mm
12 mm	-0.006 ... -0.033 mm

Dimensions in mm

Dim.:	∅	
A	10 mm*	12 mm*
B	28 mm	33 mm

* Tolerance
H7 = 0 ... +0.018 mm

Incremental Shaft Encoders Type RI 58-H

Industrial types Hollow shaft

PIN ASSIGNMENT

Connecting cable		Output	
Colour	Lead \varnothing	RS 422 T and R	push-pull K and I
red	0.5 mm ²	DC 5/10 - 30 V	DC 10 - 30 V
red/yellow	0.14 mm ²	Sense VCC	Sense VCC
white	0.14 mm ²	Channel A	Channel A
white/brown	0.14 mm ²	Channel \bar{A}	Channel \bar{A} ¹
green	0.14 mm ²	Channel B	Channel B
green/brown	0.14 mm ²	Channel \bar{B}	Channel \bar{B} ¹
yellow	0.14 mm ²	Channel N	Channel N
yellow/brown	0.14 mm ²	Channel \bar{N}	Channel \bar{N} ¹
black	0.5 mm ²	GND	GND
black/yellow	0.14 mm ²	Alarm /Sense GND ²	Alarm
screen ³		screen ³	screen ³

¹ only push-pull complementary (I)

² depending on ordering code

³ connected with encoder housing

ORDERING INFORMATION

Type	Model	Number of pulses	Supply voltage	Flange, Protection, Shaft	Output	Connection
<input type="checkbox"/>	<input type="checkbox"/>	<input type="text"/>	<input type="checkbox"/>	<input type="text"/>	<input type="checkbox"/>	<input type="checkbox"/>
RI58-	H Hollow shaft	1 ... 5 000	A DC 5 V ¹ E DC 10 - 30 V ² (only with push-pull)	S.42 Synchro, IP64, 10 mm S.47 Synchro, IP64, 12 mm	K push-pull T RS 422+ Sense R RS 422+ Alarm I push-pull complementary	B PVC cable radial
¹ with output T, R ² with output K, I, R						

ACCESSORIES

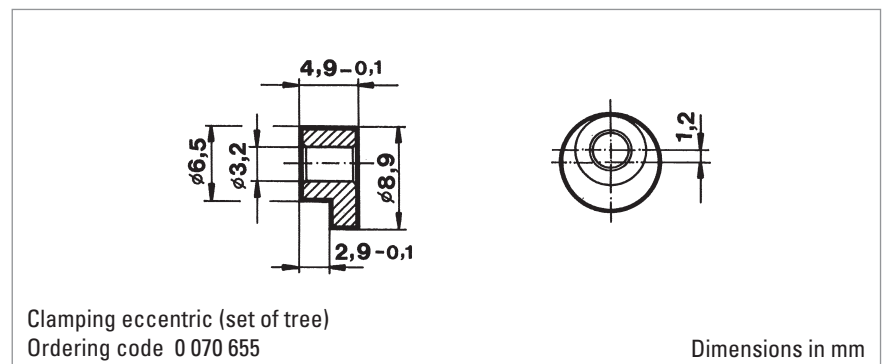

Industrial types

Hollow shaft



- Flexible hollow shaft design up to diameter 14 mm
- Short overall length
- Easy installation by means of clamping shaft or blind shaft
- Application e.g.:
 - actuators
 - length measuring machines
 - motors
- Operating temperature up to 100 °C (RI 58 TD)
- Various shaft versions:
 - Mounting code E = Blind shaft (not through)
 - Mounting code F = Clamping shaft (not through)
 - Mounting code D = Clamping shaft (solid shaft)

NUMBER OF PULSES

RI 58-D 1 / 2 / 3 / 4 / 5 / 10 / 20 / 25 / 30 / 35 / 40 / 45 / 50 / 60 / 64 / 70 / 72 / 80 / **100** / 125 / 128 / 144 / 150 / 180 / 200 / **250** / 256 / 300 / 314 / 350 / 360 / 375 / 400 / 460 / 480 / **500** / 512 / 600 / 625 / 720 / 900 / **1000** / **1024** / **1250** / 1500 / 1600 / 1800 / 2000 / 2048 / **2500** / 3000 / 3480 / **3600** / 4000 / **4096** / **5000**

RI 58 TD (high temperature) as above, but only for the range from 4 ... 2500 pulses
Other number of pulses on request
Preferably available versions are printed in bold type.

TECHNICAL DATA mechanical

Mounting	Synchro flange with clamping shaft or blind shaft
Shaft diameter	Hollow shaft 10 mm, hollow shaft 12 mm, hollow shaft 14 mm (not through)
Required dimensions of mounting shaft	Ø 10 mm, tolerance g8 (-0.005...-0.027 mm) Ø 12/14 mm, tolerance g8 (-0.006...-0.033 mm)
Absolute max. speed	E, F: max. 6000 min ⁻¹ ; D: max 4000 min ⁻¹
Torque	≤ 1 Ncm with non-through shaft (E, F) ≤ 2 Ncm with through shaft (D)
Moment of inertia	F: approx. 35 gcm ² (clamping non through shaft) E: approx. 20 gcm ² (end shaft) D: approx. 60 gcm ² (clamping through shaft)
Protection class (EN 60529)	E, F: housing IP65, bearings IP64 D: housing IP64, bearings IP64
Operating temperature	-10 ... +70 °C, Option: -25 ...+100°C
Storage temperature	-25 ... +85 °C
Vibration resistance (IEC 68-2-6)	10 g = 100 m/s ² (10 ... 2000 Hz)
Shock resistance (IEC 68-2-27)	100 g = 1000 m/s ² (6 ms)
Connection	1.5 m cable ¹ or connector, radial
Housing	Aluminium
Weight approx.	E, F: 170 g; D: 190 g

¹ Other cable length on request

Incremental Shaft Encoders

Type RI 58-D

Industrial types

Hollow shaft

TECHNICAL DATA electrical

General design	as per DIN VDE 0160, protection class III, contamination level 2, overvoltage class II	
Supply voltage (SELV)	with RS 422 + Sense (T):	DC 5 V ± 10 %
	with RS 422 + Alarm (R):	DC 5 V ± 10 % oder DC 10 - 30 V ¹
	with push-pull (K, I):	DC 10 - 30 V ¹
Max. current w/o load	40 mA (5 VDC), 60 mA (10 VDC), 30 mA (24 VDC)	
Standard output versions ²	RS 422 (R):	A, B, N, \bar{A} , \bar{B} , \bar{N} , Alarm
	RS 422 (T):	A, B, N, \bar{A} , \bar{B} , \bar{N} , Sense
	push-pull (K):	A, B, N, Alarm
	push-pull complementary (I):	A, B, N, \bar{A} , \bar{B} , \bar{N} , Alarm

¹ Pole protection with supply voltage DC 10 - 30 V

² Output description and technical data see chapter "Technical basics"

DIMENSIONAL DRAWINGS

Mounting = F: clamping shaft, not through

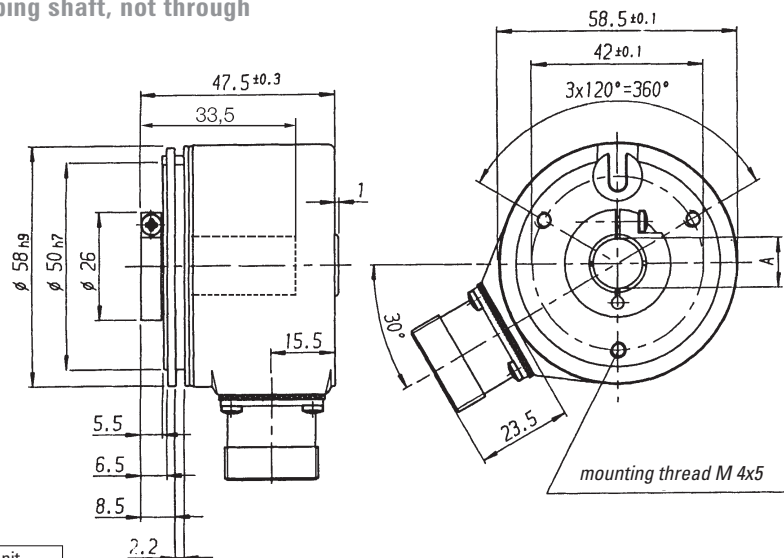

Dim.:	Hollow shaft Ø	Unit
A	10 ^{H7} 12 ^{H7} 14 ^{H7}	mm
A*	10 ^{g8} 12 ^{g8} 14 ^{g8}	mm

A* = Diameter of connection shaft

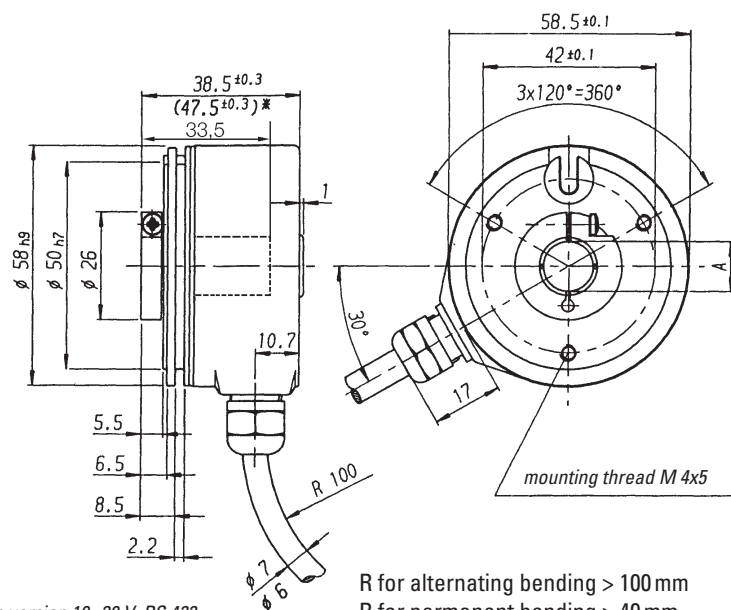

Dimensions in mm

* with version 10 - 30 V RS 422

R for alternating bending > 100 mm
R for permanent bending > 40 mm

Incremental Shaft Encoders Industrial types

Type RI 58-D Hollow shaft

DIMENSIONAL DRAWINGS

Mounting = D: through shaft with clamping ring

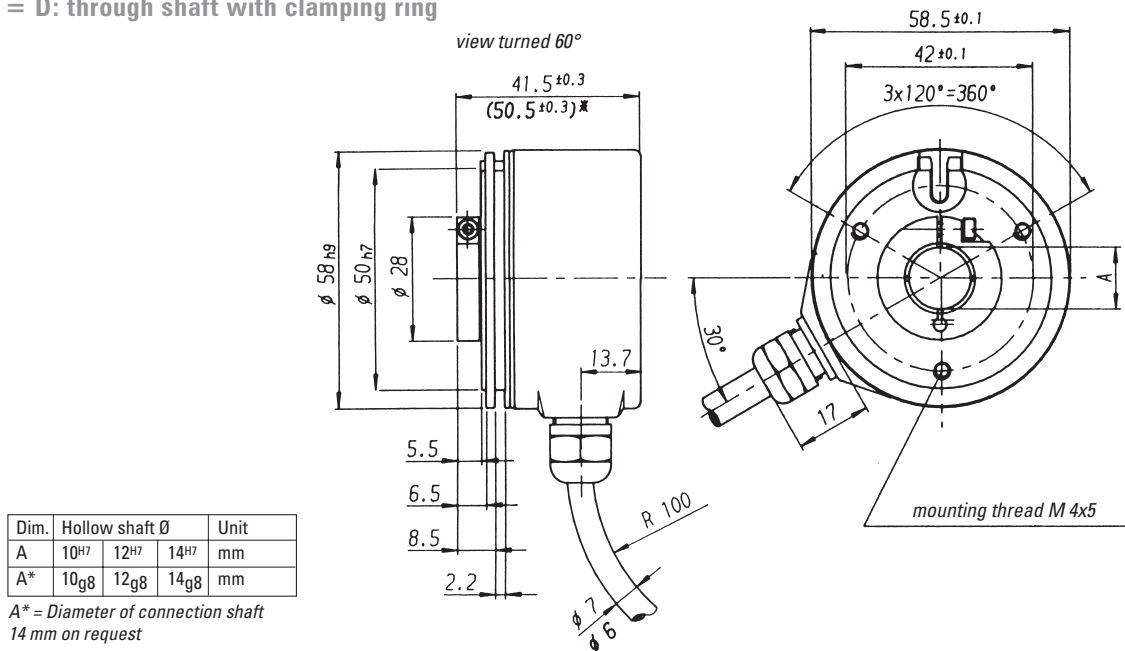

* with Version 10 - 30 V RS 422

Dimensions in mm

R for alternating bending > 100 mm
R for permanent bending > 40 mm

H optional:
Clamping ring at rear on request

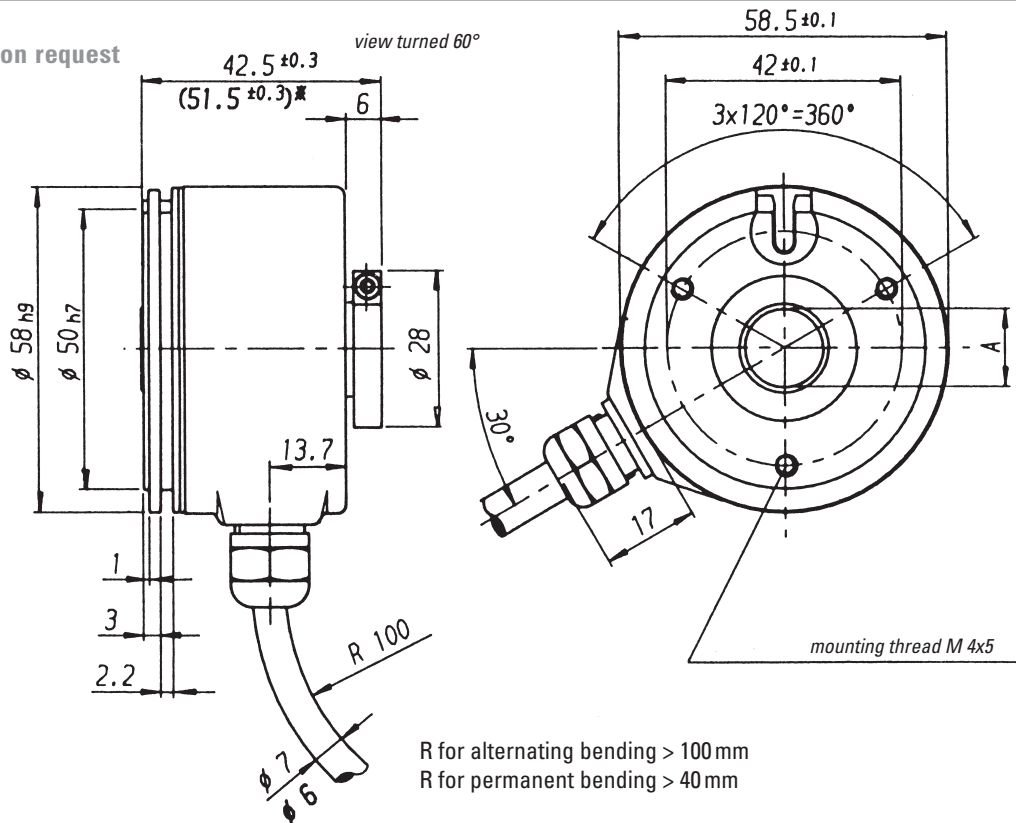

Dimensions in mm

R for alternating bending > 100 mm
R for permanent bending > 40 mm

Incremental Shaft Encoders Industrial types

Type RI 58-D Hollow shaft

DIMENSIONAL DRAWINGS

Mounting = E, blind shaft (not through)

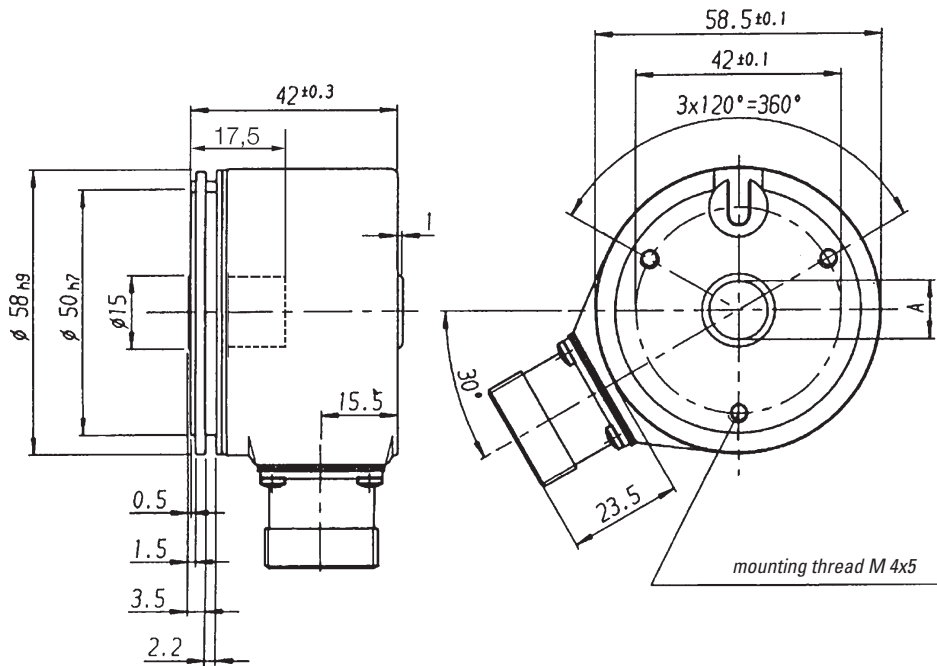

Dim.	Hollow shaft Ø	Unit
A	10 ^{H7} 12 ^{H7} 14 ^{H7}	mm
A*	10 ^{g8} 12 ^{g8} 14 ^{g8}	mm

A* = Diameter of connection shaft

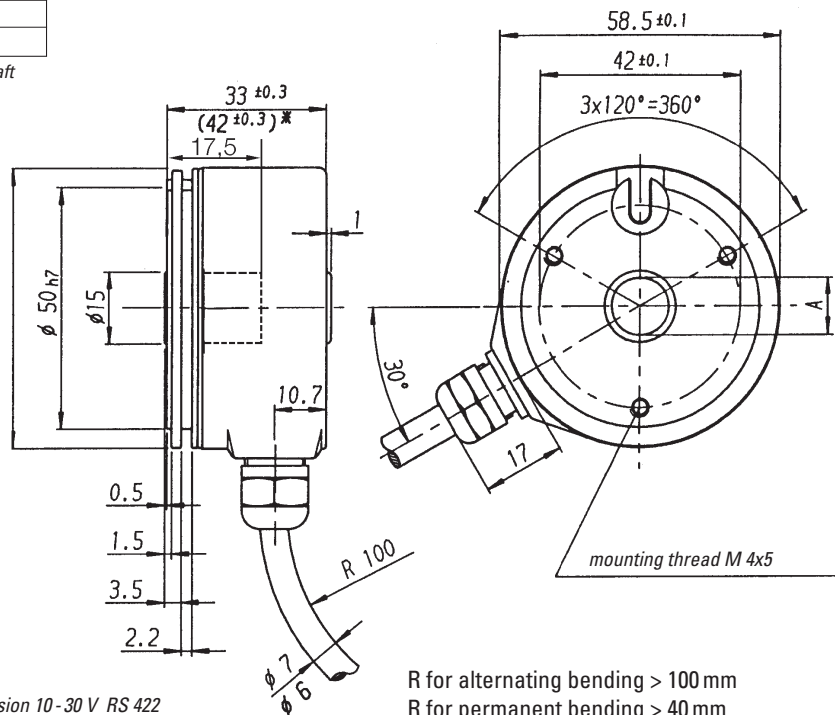

* with Version 10-30 V RS 422

R for alternating bending > 100 mm
R for permanent bending > 40 mm

Dimensions in mm

Industrial types

Hollow shaft

MOUNTING NECESSITIES

In order to be able to compensate an axial and radial misalignment of the shaft, the encoder flange must not be fixed rigidly. Fix the flanges by means of a stator coupling (e.g. hubshaft with tether) as torque support (see "Accessories") or by means of a cylindrical pin:

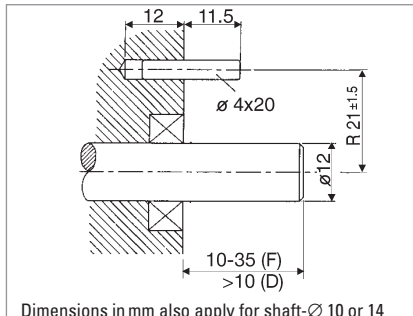

Dimensions in mm also apply for shaft- \varnothing 10 or 14

Mounting = D, F (Clamping shaft)

Preparation of the machine flange ¹

(all mounting versions):

In the machine flange a straight pin must be installed (diameter 4x16 resp. 4x20, DIN 6325).

This pin is required as a torque support.

¹ Or as an option: stator coupling as torque support

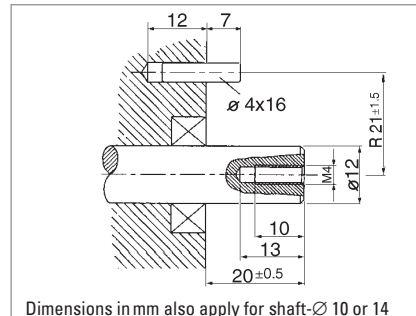

Dimensions in mm also apply for shaft- \varnothing 10 or 14

Mounting = E (Blind shaft)

Preparation of the drive shaft

(only in mounting = E):

The drive shaft must be provided with a threaded bore M 4 x 10:

This bore accepts the fastening screw of the shaft encoder.

PIN ASSIGNMENT

Cable PVC

Cable	Output circuit			
	RS 422 + Sense (T)	RS 422 + Alarm (R)	push-pull (K)	push-pull complementary (I)
white	Channel A	Channel A	Channel A	Channel A
white/brown	Channel \bar{A}	Channel \bar{A}		Channel \bar{A}
green	Channel B	Channel B	Channel B	Channel B
green/brown	Channel \bar{B}	Channel \bar{B}		Channel \bar{B}
yellow	Channel N	Channel N	Channel N	Channel N
yellow/brown	Channel \bar{N}	Channel \bar{N}		Channel \bar{N}
yellow/black	Sense GND	Alarm	Alarm	Alarm
yellow/red	Sense V _{CC}	Sense V _{CC}		Sense V _{CC}
red	DC 5 V	DC 5/10 - 30 V	DC 10 - 30 V	DC 10 - 30 V
black	GND	GND	GND	GND
Cable screen ¹	Cable screen ¹	Cable screen ¹	Cable screen ¹	Cable screen ¹

¹ connected with encoder housing

PIN ASSIGNMENT

Cable TPE

Cable	Output circuit			
	RS 422 + Sense (T)	RS 422 + Alarm (R)	push-pull (K)	push-pull complementary (I)
brown	Channel A	Channel A	Channel A	Channel A
green	Channel \bar{A}	Channel \bar{A}		Channel \bar{A}
grey	Channel B	Channel B	Channel B	Channel B
pink	Channel \bar{B}	Channel \bar{B}		Channel \bar{B}
red	Channel N	Channel N	Channel N	Channel N
black	Channel \bar{N}	Channel \bar{N}		Channel \bar{N}
violet (white) ²	Sense GND	Alarm	Alarm	Alarm
blue	Sense V _{CC}	Sense V _{CC}		Sense V _{CC}
brown/green	DC 5 V	DC 5/10 - 30 V	DC 10 - 30 V	DC 10 - 30 V
white/green	GND	GND	GND	GND
Cable screen ¹	Cable screen ¹	Cable screen ¹	Cable screen ¹	Cable screen ¹

Incremental Shaft Encoders Type RI 58-D

Industrial types Hollow shaft

PIN ASSIGNMENT Connector (CONIN)

Pin	RS 422 + Sense (T)	RS 422 + Alarm (R)	push-pull (K)	push-pull complementary (I)
1	Channel \bar{B}	Channel \bar{B}	N.C.	Channel \bar{B}
2	Sense V_{CC}	Sense V_{CC}	N.C.	Sense V_{CC}
3	Channel N	Channel N	Channel N	Channel N
4	Channel \bar{N}	Channel \bar{N}	N.C.	Channel \bar{N}
5	Channel A	Channel A	Channel A	Channel A
6	Channel \bar{A}	Channel \bar{A}	N.C.	Channel \bar{A}
7	N.C.	Alarm	Alarm	Alarm
8	Channel B	Channel B	Channel B	Channel B
9	N.C. ¹	N.C. ¹	N.C. ¹	N.C. ¹
10	GND	GND	GND	GND
11	Sense GND	N.C.	N.C.	N.C.
12	DC 5 V	DC 5 / 10 - 30 V	DC 10 - 30 V	DC 10 - 30 V

¹ screen for cable with CONIN connector

ACCESSORIES

Hubshaft with tether as stator coupling: ordering code 1 531 162

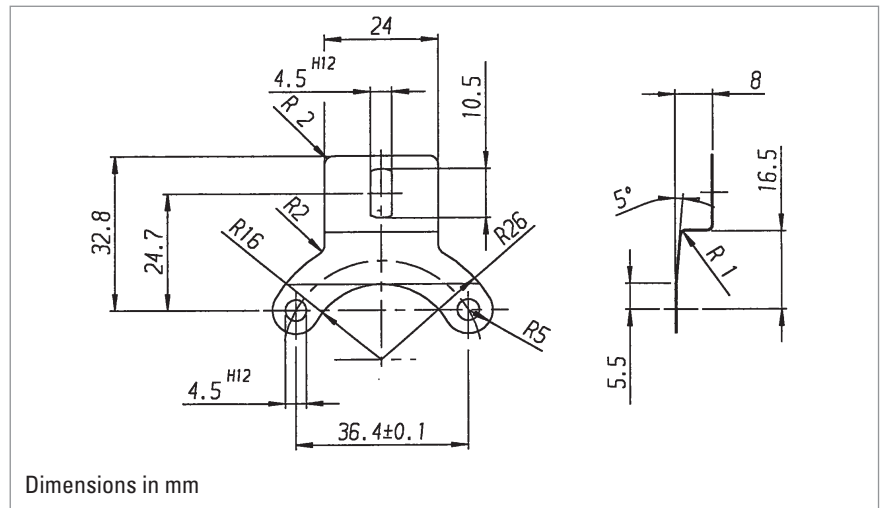

ORDERING INFORMATION

Type	Model	Number of pulses	Supply voltage	Flange, Protection, Shaft	Output	Connection
RI58-	D Hollow shaft TD Hollow shaft 100 °C	1 ... 5 000	A DC 5 V ⁴ E DC10 - 30 V ⁵ (only with push-pull)	E.42 Blind shaft ¹ , IP64/64, 10 mm E.47 Blind shaft ¹ , IP64/64, 12 mm E.49 Blind shaft ¹ , IP64/64, 14 mm F.42 Blind shaft ¹ , IP64/64, 10 mm F.47 Blind shaft ¹ , IP64/64, 12 mm F.49 Blind shaft ¹ , IP64/64, 14 mm D.32 Clamping shaft front ² , IP64/64, 10 mm D.37 Clamping shaft front ² , IP64/64, 12 mm	K push-pull T RS 422 + Sense R RS 422 + Alarm I push-pull complementary	B PVC cable radial F TPE cable radial D CONIN radial, cw ³ H CONIN radial, ccw ³

¹ Mounting E, F: no through shaft (blind hole)

² through shaft, only connection cable

³ only with mounting E or F (no through shaft)

⁴ with output T, R

⁵ with output K, I, R

Incremental Shaft Encoders **Type RI 76 TD**

Industrial types **Hollow shaft**



- Through shaft with up to diameter 42 mm
- Short overall length with an outside diameter of only 76 mm
- Easy installation by means of clamping ring
- Operating temperature up to 100 °C
- Application e.g.:
 - motors
 - printing machines
 - lifts

NUMBER OF PULSES

50 / 100 / 128 / 250 / 256 / 300 / 314 / 360 / 500 / 600 / 720 / 900 / 1000 / 1024 / 1250 / 1500 / 2048 / 2500 / 3072 / 4096 / 5000 / 8192 / 9000 / 10000
 Other number of pulses on request

TECHNICAL DATA mechanical

Shaft fixation	Clamping ring, front or rear
Coupling	stator coupling (hubshaft with tether)
Shaft diameter	15...42 mm (Available: 15, 16, 18, 20, 24, 25, 27, 28, 30, 32, 38, 40, 42 mm as well as $\frac{5}{8}$ " , $1\frac{5}{8}$ " , $\frac{3}{4}$ "
Minimum length of mounting shaft	
Front clamping ring	32 mm with \emptyset 15...30, 35 mm with \emptyset >30 ... 42
Rear clamping ring	corresponding to total length of encoder
Max. parallel shaft misalignment	
with stator coupling A (flexible)	± 2.0 mm axial, ± 0.15 mm radial
with 1x stator coupling N (torsionally rigid)	± 0.5 mm axial, ± 0.3 mm radial
with 2x stator coupling N (torsionally rigid)	± 0.3 mm axial, ± 0.2 mm radial
Absolute max. speed	at 70 °C and IP64: 3 600 min ⁻¹ für \emptyset 15... 25 at 70 °C and IP64: 1 800 min ⁻¹ für \emptyset >25 ... 42 at 70 °C and IP40: 6 000 min ⁻¹ für \emptyset 15... 42 at 100 °C always: 1 800 min ⁻¹ für \emptyset 15... 42
Torque	3...10 Ncm (depending on version)
Moment of inertia	140...420 gcm ² (depending on version)
Protection class (EN 60529)	Housing IP50, bearings IP40 Option: Housing IP65, bearings IP64
Operating temperature	-25 ... +100 °C
Storage temperature	-25 ... +100 °C
Vibration resistance (IEC 68-2-6)	10 g = 100 m/s ² (10... 2000 Hz)
Shock resistance (IEC 68-2-27)	100 g = 1000 m/s ² (6 ms)
Connection	1.5 m cable ¹ radial
Housing	Aluminium
Weight	320 - 580 g (depending on version)

¹ Other cable length on request

Incremental Shaft Encoders Type RI 76 TD

Industrial types Hollow shaft

TECHNICAL DATA electrical

General design	as per DIN EN 61010-Part 1, protection class III, Contamination level 2, over voltage level II	
Supply voltage (SELV)	with RS 422 +Sense (T): DC 5 V ± 10 % with RS 422 +Alarm (R): DC 5 V ± 10 % oder DC 10 - 30 V ¹ with push-pull (K, I): DC 10 - 30 V ¹	
Max. current w/o load	max. 60 mA (DC 5V), 60 mA (DC 10V), 35 mA (DC 24 V)	
Standard output versions ²	RS 422 (R):	A, B, N, \bar{A} , \bar{B} , \bar{N} , Alarm
	RS 422 (T):	A, B, N, \bar{A} , \bar{B} , \bar{N} , Sense
	push-pull (K):	A, B, N, Alarm
	push-pull complementary (I):	A, B, N, \bar{A} , \bar{B} , \bar{N} , Alarm

¹ Pole protection with supply voltage DC 10 - 30 V

² Output description and technical data see chapter "Technical basics"

DIMENSIONAL DRAWINGS

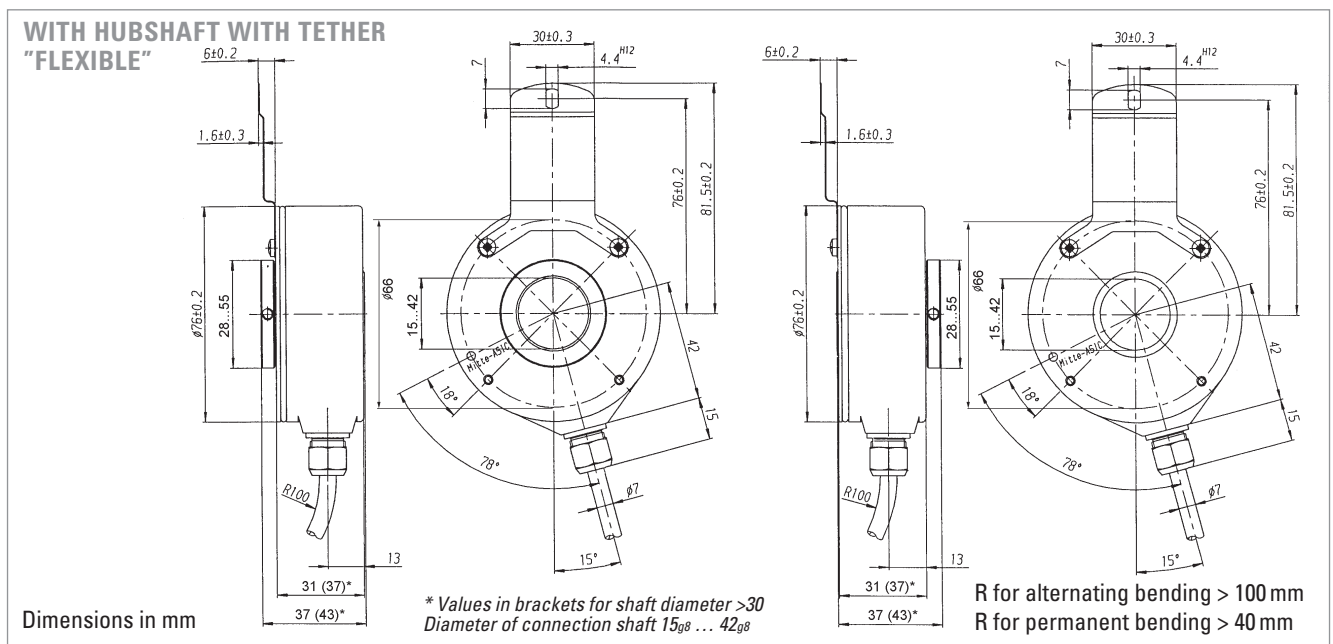
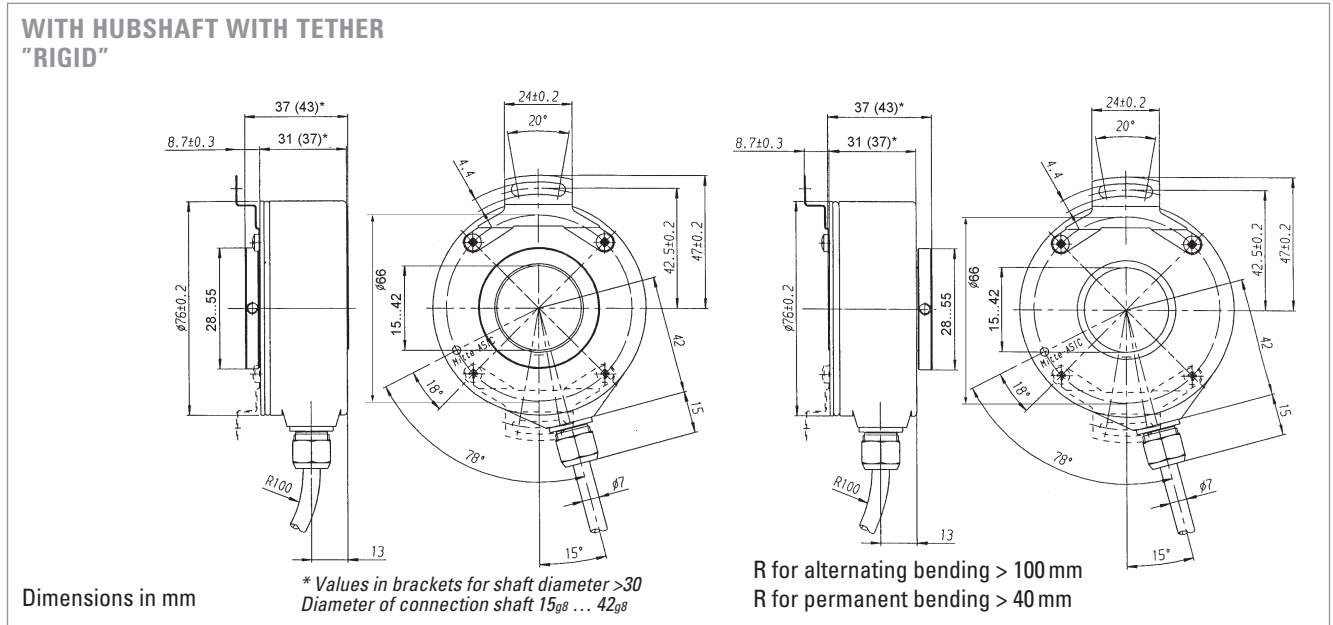

Industrial types

Hollow shaft

SHAFT CONNECTION

Shaft fixing is done through a clamping ring either on the flange or cap side. As a rule, flange side clamping is better for smaller motors as the available shaft stub is correspondingly shorter.

On the other hand, cap side clamping is easier when there is sufficient shaft length available.

MOUNTING NECESSITIES

In order to compensate for axial and radial shaft eccentricity as well as any angle offset, the encoder flange must not be rigidly mounted. Please mount the flange with a flexible stator coupling (e.g. hubshaft with tether) as torque support.

There are two flexible mounting plates:

- A flexible hubshaft with tether (A) for higher levels of play and lower requirements for accuracy.
- A rigid hubshaft with tether (N) for reduced play and rigid connection with reduced swing angle. This is suitable in the case of higher accuracy and dynamics requirements.

PIN ASSIGNMENT

Cable TPE

Colour (TPE)	Output circuit			
	RS 422 + Sense (T)	RS 422 + Alarm (R)	push-pull (K)	push-pull complementary (I)
brown	Channel A	Channel A	Channel A	Channel A
green	Channel \bar{A}	Channel \bar{A}		Channel \bar{A}
grey	Channel B	Channel B	Channel B	Channel B
pink	Channel \bar{B}	Channel \bar{B}		Channel \bar{B}
red	Channel N	Channel N	Channel N	Channel N
black	Channel \bar{N}	Channel \bar{N}		Channel \bar{N}
violet (white) ²	Sense GND	Alarm	Alarm	Alarm
blue	Sense V _{CC}	Sense V _{CC}		Sense V _{CC}
brown/green	DC 5 V	DC 5/10 .- 30 V	DC 10 - 30 V	DC 10 - 30 V
white/green	GND	GND	GND	GND
Cable screen ¹	Cable screen ¹	Cable screen ¹	Cable screen ¹	Cable screen ¹

¹ connected with encoder housing

² white for version Sense (T)

ACCESSORIES

Hubshaft with tether flexible	ordering code 1 533 079
Hubshaft with tether rigid	ordering code 1 533 078

Incremental Shaft Encoders Type RI 76 TD

Industrial types Hollow shaft

ORDERING INFORMATION

Type	Model	Number of pulses	Supply voltage	Flange	Protection	Stator coupling	Shaft	Output	Connection
<input type="checkbox"/>	<input type="checkbox"/>	<input type="checkbox"/>	<input type="checkbox"/>	<input type="checkbox"/>	<input type="checkbox"/>	<input type="checkbox"/>	<input type="checkbox"/>	<input type="checkbox"/>	<input type="checkbox"/>
RI76	TD High temperature, direct hollow shaft	1...10 000	A DC 5 V ¹ E DC 10-30 V ²	Clamping shaft with D Front clamping ring H Rear clamping ring	1 IP40 4 IP64	O without A flexible N rigid	15...42 metric in mm 50...99 coded by inches 50 = 5/8" 51 = 1 5/8" 52 = 3/4"	R RS 422 + Alarm T RS 422 + Sense K push-pull I push-pull complementary	F TPE cable radial

¹ only with output R, T,

² only with output R, K, I

³ Available with front clamping ring and IP40: **15, 20, 24, 25, 27, 28, 30, 38, 40, 42, 50** (5/8"), **51** (1 5/8")

Available with front clamping ring and IP64: **15, 16, 18, 20, 24, 25, 27, 28, 30, 32, 38, 40, 42, 50** (5/8"), **51** (1 5/8"), **52** (3/4")

Available with rear clamping ring and IP40: **25, 28, 30, 32, 38, 40, 42**

Available with rear clamping ring and IP64: **20, 25, 30, 32, 38, 40, 42**

Preferably available versions are printed in bold type.

Others: please request delivery time

PRELIMINARY



GENERAL INFORMATION

NUMBER OF PULSES

TECHNICAL DATA mechanical

TECHNICAL DATA electrical

Incremental Shaft Encoders

Type RI 80-E

Industrial types

Hollow shaft

- Incremental Output
- 30...45 mm hollow shaft
- Rugged mechanical design
- Unbreakable disc
- Integrated diagnostic system
- Wide voltage range DC 5 ... 30 V

The central element of the RI80-E is the latest Hengstler OptoAsic technology, which offers the following key benefits:

- Highest EMC immunity
- Outstanding reliability by reduced number of components and integrated diagnostics system
- Aging compensation by integrated LED light regulation
- Integrated monitoring of pollution, disk damage, LED lifetime, temperature

A robust and generously dimensioned mechanical design ensures long maintenance free operation.

The RI80-E is ideally suited for applications like:

- Geared Elevators
- Asynchronous Motors
- Industrial Machinery

1024 / 2048 / 4096

Other number of pulses on request

Shaft fixation	Keyway, set screw
Coupling	Spring tether (single, double)
Protection	IP50, IP64
Max. Speed	3 600 min ⁻¹ (IP50) 1 500 min ⁻¹ (IP64)
Moment of inertia	240 kgmm ²
Max. parallel shaft misalignment	axial: ± 0.5 mm radial: ± 0.05 mm
Operating temperature	-20 ...+70°C
Storage temperature	-40 ...+70°C
Material housing	Glass fiber-reinforced plastic/ aluminum
Weight	1000 g

General design	As per DIN EN 61010, protection class III, Contamination level 2 , over voltage class II
Supply voltage	DC 5V±10% or DC 5 - 30V ¹
Max. current w/o load	max 60mA (DC 5V), 60mA (DC 10V), 35mA (DC 24V)
Standard output versions	With RS 422 (R): A, B, N, \bar{A} , \bar{B} , \bar{N} , Alarm, Sense With push-pull (K): A, B, N, $\overline{\text{Alarm}}$ With push-pull (I): A, B, N, \bar{A} , \bar{B} , \bar{N} , $\overline{\text{Alarm}}$, Sense
Connection	Sub-D 15-pole, cable radial

¹ Pole protection with supply voltage DC 5 ...30 V

Incremental Shaft Encoders Industrial types

Type RI80-E Hollow shaft

DIMENSIONAL DRAWINGS

SET SCREW

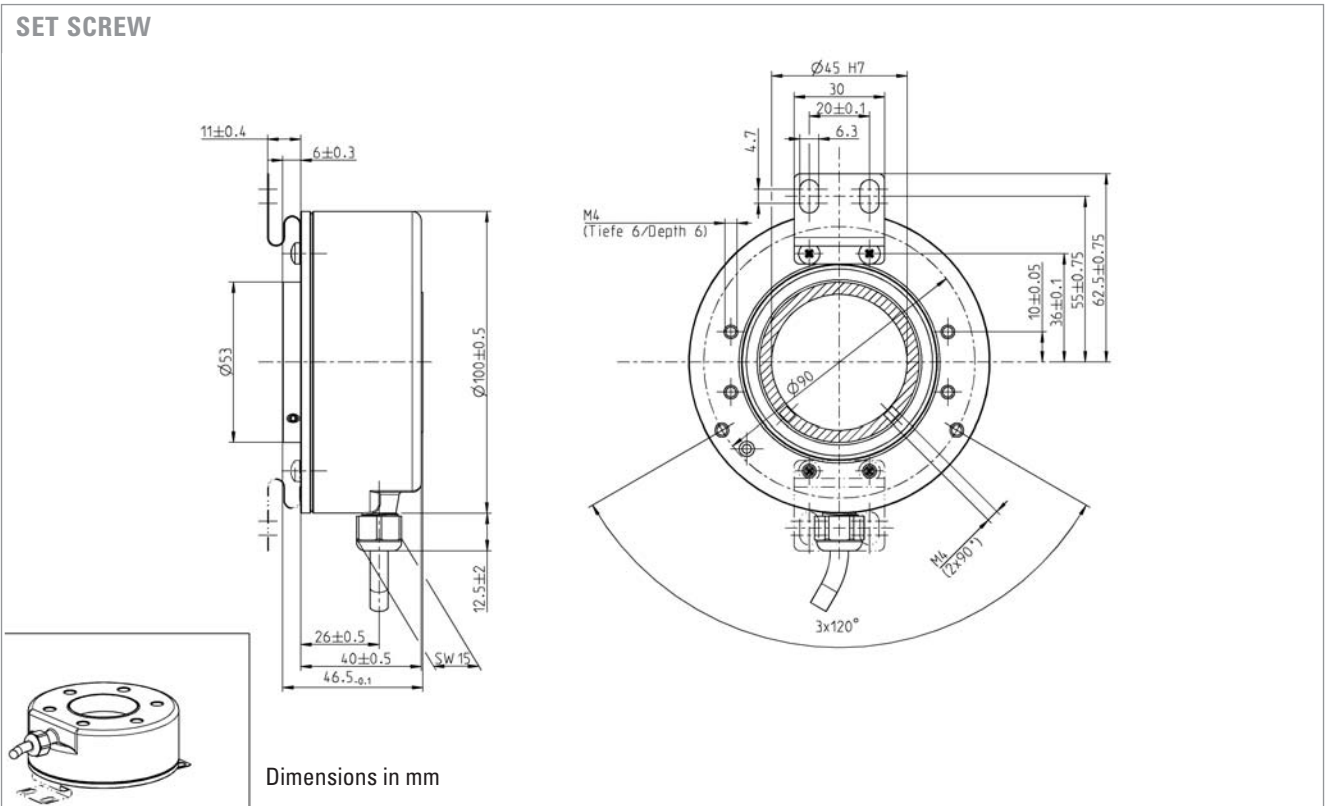

KEYWAY

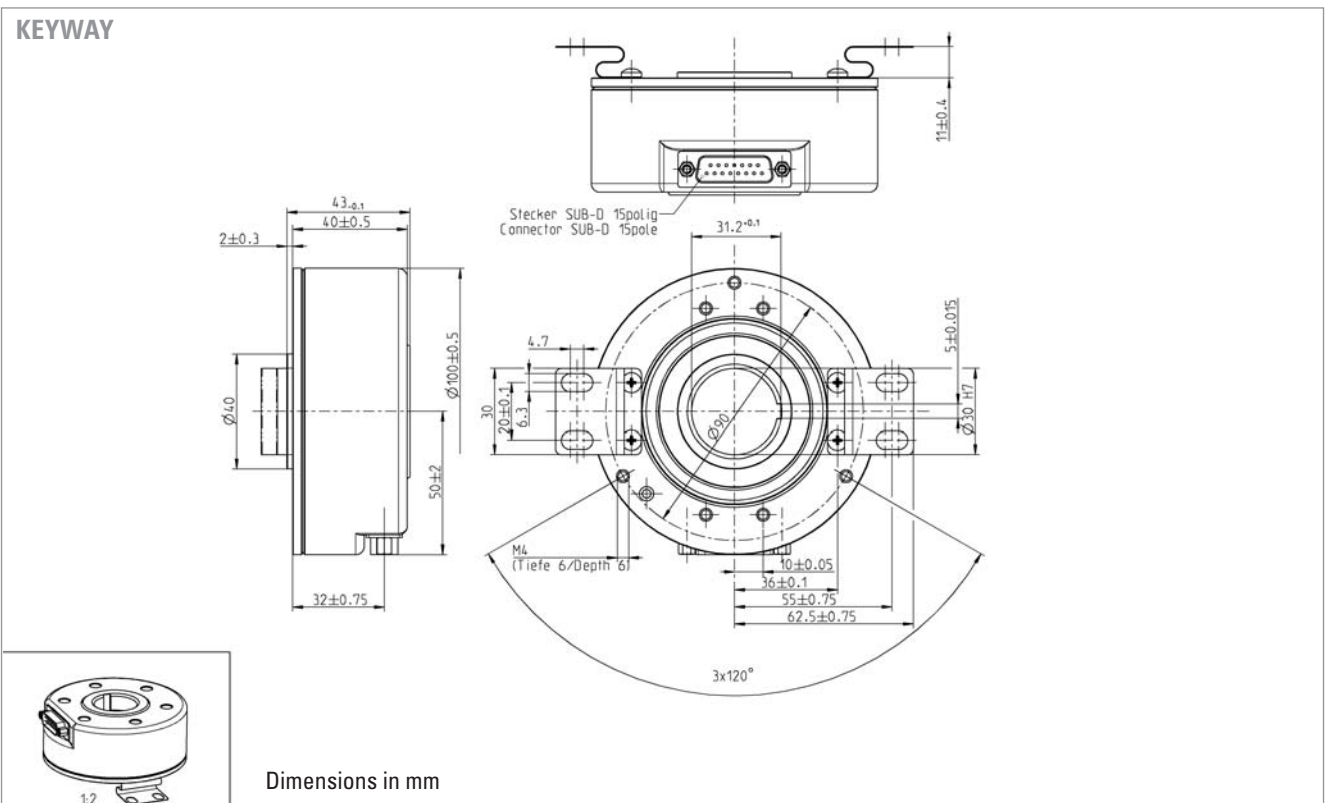

Incremental Shaft Encoders

Type RI 80-E

Industrial types

Hollow shaft

PIN ASSIGNMENT Cable

Color	RS 422 + Alarm + Sense (R)	Push-pull (K)	Push-pull Complement. (I)
brown	Channel A	Channel A	Channel A
green	Channel \bar{A}		Channel \bar{A}
grey	Channel B	Channel B	Channel B
pink	Channel \bar{B}		Channel \bar{B}
red	Channel N	Channel N	Channel N
black	Channel \bar{N}		Channel \bar{N}
violet	Alarm	Alarm	Alarm
white	Sense GND		Sense GND
blue	Sense V_{CC}		Sense V_{CC}
brown/green	DC 5 - 30 V	DC 5 - 30 V	DC 5 - 30 V
white/green	GND	GND	GND
screen ¹	screen ¹	screen ¹	screen ¹

¹ connected with encoder housing

PIN ASSIGNMENT Sub-D 15 pin

Pin	Signal
1	\bar{B}
2	B
3	\bar{A}
4	A
5	GND
6	+Ub
7	n.c.
8	screen
9	\bar{N}
10	N
11	n.c.
12	n.c.
13	n.c.
14	n.c.
15	n.c.

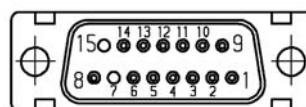

ORDERING INFORMATION

Type	Model	Number of pulses	Supply voltage	Spring tether	Protection	Mounting/ shaft	Output	Connection
<input type="text"/>	<input type="text"/>	<input type="text"/>	<input type="text"/>	<input type="text"/>	<input type="text"/>	<input type="text"/>	<input type="text"/>	<input type="text"/>
RI80-	E	1024 2048 4096	A DC 5 V B DC 5 - 30 V	A single B double O without	1 IP50 4 IP64 0 IP40	K30 Keyway/ 30mm G30 Set screw/ 30mm G45 Set screw/ 45mm	R RS422 + Alarm + Sense K Push-pull ¹ I Push-pull complementary ¹	F Cable radial 1.5 m F-F0 Cable radial 5 m F-K0 Cable radial 10 m 4 SUB-D 15

¹ Driver type DL, see < www.ichaus.de >

Incremental Shaft Encoders Type PC 9/PC 9S

Economy Types

Panelcoders™



- Provides digital control inputs from operators's panel
- Bidirectional squarewave signal outputs
- Up to 512 increments
- Continuous and reversible rotation
- Non-contacting
- Operating temperature -40 ... 100 °C

NUMBER OF PULSES

100 ... 512

TECHNICAL DATA mechanical

Shaft load	1/8" Shaft: 4 N axial, 27 N radial 1/4" Shaft: 4 N axial, 4 N radial
Moment of inertia	0.20 gcm ²
Operating temperature	-40 ... +100 °C
Storage temperature	-50 ... +125 °C
Relative humidity	90 %, non-condensing
Connection	PC9: 10 pole header PC9S: 5 pole header
Recommended mating connectors	PC9: Thomas & Betts, part number 622-1030 (on request) PC9S: AMP, part number 103675-4 (on request)

TECHNICAL DATA electrical

Code	Incremental, optical
Phasing	90° ±18° electrical
Symmetry	180° ±18° electrical
Index pulse width	90° ±36° electrical
Supply voltage	DC 5 V ±10 %
Supply current	10 mA, typical
Standby current	max. 50 µA (PC9 only)
Output signals	min. 2.5 V high (V _{OH}) max. 0.5 V low (V _{OL})
Output current	PC9: 3 mA sink/source (25 °C), 2 mA (100 °C) PC9S: 6 mA sink/source (25 °C), 4 mA (100 °C)
Max. output frequency	200 kHz

Incremental Shaft Encoders Type PC 9/PC 9S

Economy Types Panelcoders™

DIMENSIONAL DRAWINGS

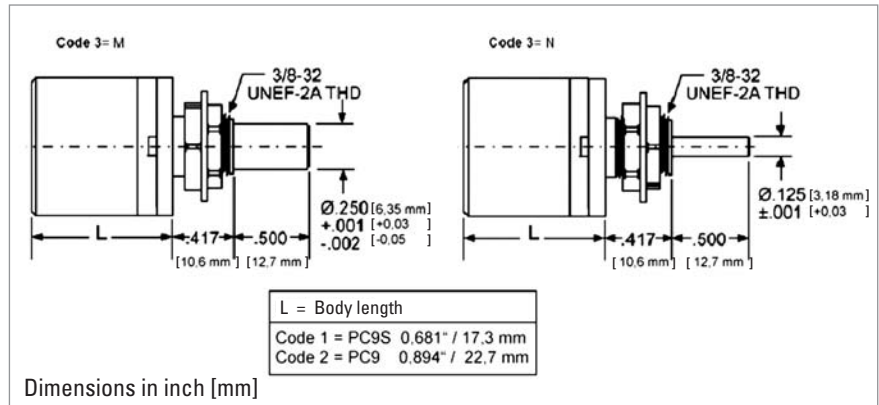

OUTPUT WAVEFORMS

□ CONNECTIONS PC9

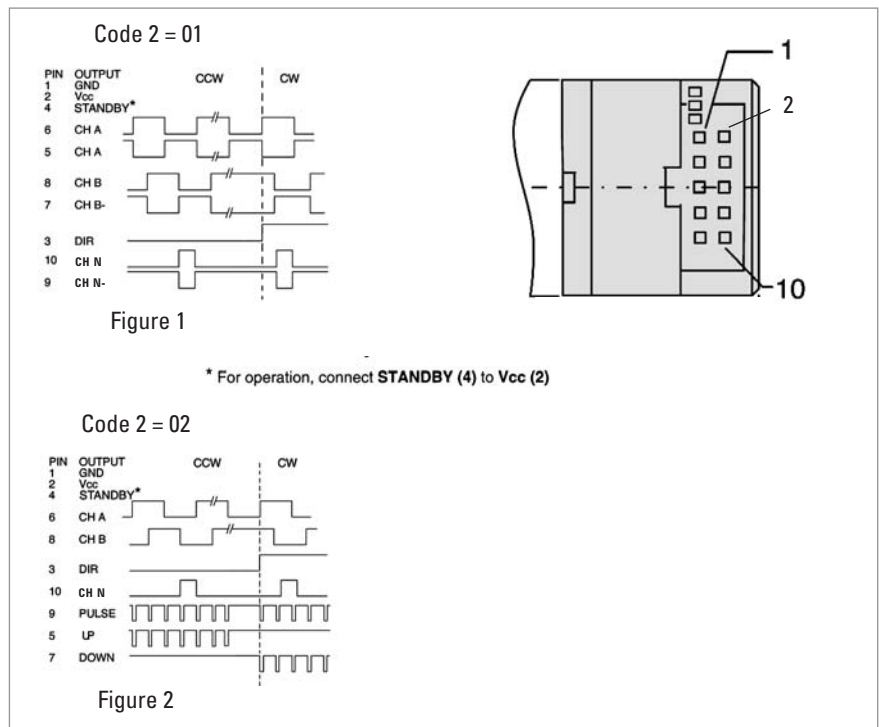

ACCESSORIES PC9

	ordering code
10 pole header, 30 cm ribbon cable with connector	CA 0 040 012

ORDERING INFORMATION PC9

Type	Number of pulses	Code 2: Output	Mounting
□	□	□	□
PC9	0100	01 see figure 1	M 1/4" Shaft, sleeve bearing
	0144		
	0200	N 1/8" Shaft, ball bearings	
	0256		
	0300		
	0360		
	0500		
0512			

Incremental Shaft Encoders Type PC 9/PC 9S

Economy Types

Panelcoders™

OUTPUT WAVEFORMS □ CONNECTIONS PC9S

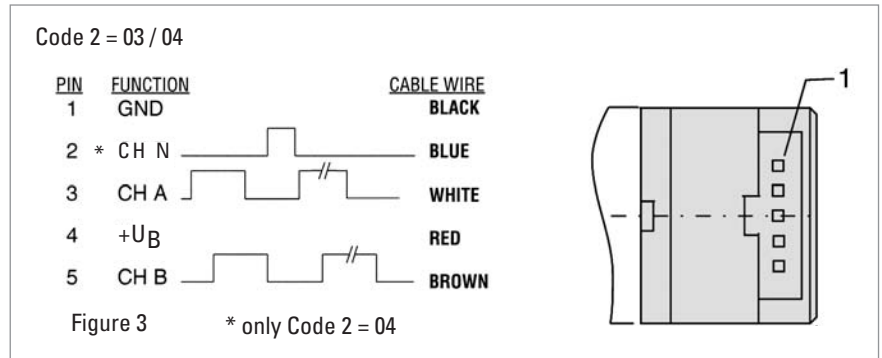

ACCESSORIES PC9S

5 pole header, 30 cm cable with connector	ordering code CA 0 050 012
---	-------------------------------

ORDERING INFORMATION PC9S

Type	Number of pulses	Code 2: Output	Mounting
□	□	□	□
PC9S	0 100 0 144 0 200 0 256 0 300 0 360 0 500 0 512	03 see figure 3 (no index) 04 see figure 3	M 1/4" Shaft, sleeve bearing N 1/8" Shaft, ball bearings

Economy Types



- Replacement for type RIS and RI 31
- The economical encoder for small appliances
- High efficiency by means of ball bearing
- Small torque
- Application e.g.
 - laboratory equipment
 - training equipment
 - crimping machines
 - tampon printing machines
 - miniature grinding machines

NUMBER OF PULSES

5 / 10 / 20 / 25 / 30 / 50 / 60 / 100 / 120 / 128 / 200 / 250 / 256 / 288 / 300 / 360 / 400 / 500 / 512 / 600 / 720 / 900 / 1000 / 1024 / 1250 / 1500
 Other number of pulses on request

TECHNICAL DATA
mechanical

Shaft diameter	5 mm/ 6 mm
Absolute max. shaft load	radial 10 N, axial 5 N
Absolute max. speed	6 000 min ⁻¹
Torque	≤ 0.05 Ncm
Protection class (EN 60529)	Housing IP50, bearings IP40
Operating temperature	-10 ... +60 °C
Storage temperature	-25 ... +85 °C
Vibration resistance (IEC 68-2-6)	100 m/s ² (10 ... 2000 Hz)
Shock resistance (IEC 68-2-27)	1000 m/s ² (6 ms)
Connection	1.5 m cable axial/radial ¹
Material	Housing: plastic; Flange: Aluminium
Flange	Pilot flange
Weight approx.	50 g

¹ Other cable length on request

TECHNICAL DATA
electrical

General design	as per DIN VDE 0160, protection class III, contamination level 2, over voltage class II	
Supply voltage (SELV)	with push-pull (D):	DC 5V ±10 %
	with push-pull (K):	DC 5V ¹ ±10 % oder DC 10 - 30V ²
Max. current w/o load	40 mA (DC 5V), 60 mA (DC 10V), 30 mA (DC 24V)	
Standard output versions ³	push-pull (K, D):	A, B, N, \bar{A} alarm

² Pole protection

³ Output description and technical data see chapter "Technical basics"

Incremental Shaft Encoders Type RI 32

Economy Types

DIMENSIONAL DRAWINGS

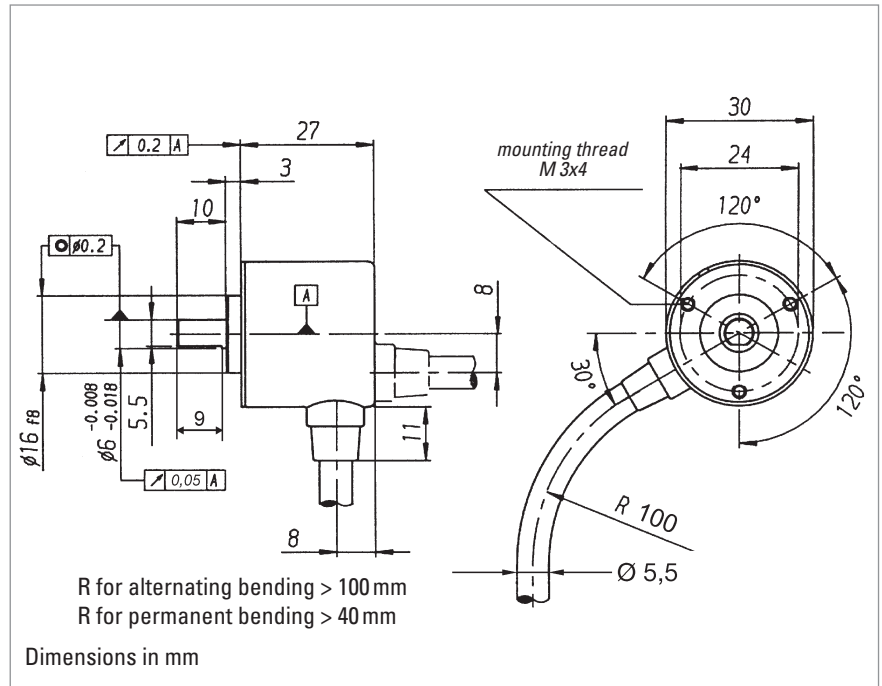

PIN ASSIGNMENT

Description (push-pull)	Lead Ø mm ²	Colour
DC 5 V/ 10 - 30 V	0.5	red
Channel A	0.14	white
Channel B	0.14	green
Channel N	0.14	yellow
GND	0.5	black
Alarm	0.14	yellow/black

ORDERING INFORMATION

Type	Model	Number of pulses	Supply voltage	Flange, Protection, Shaft	Output	Connection
<input type="checkbox"/>	<input type="checkbox"/>	<input type="text"/>	<input type="checkbox"/>	<input type="text"/>	<input type="checkbox"/>	<input type="checkbox"/>
RI32-	0 Standard	5 ... 1 500	A DC 5 V E DC 10 - 30 V ¹	R.11 Pilot, IP40, 6 mm * R.14 Pilot, IP40, 5 mm **	K push-pull ² short circuit proof D push-pull DC 5 V, ±30 mA	A Cable axial B Cable radial
<p>* flattened, see dimensional drawing ** not flattened ¹ only with output K ² ±10 mA at DC 5 V, ±30 mA at DC 10 - 30 V</p>						

Economy Types



- Replacement for type RI 39
- Encoder for universal installation by means of front/back panel mounting
- High efficiency by means of ball bearing
- Small torque
- Application e.g.:
 - FHP motors
 - laboratory equipment
 - labelling machines
 - plotters
 - length measuring machines

NUMBER OF PULSES

5 / 10 / 20 / 25 / 28 / 32 / 50 / 60 / 72 / 100 / 128 / 144 / 200 / 250 / 256 / 288 / 300 / 360 / 400 / 500 / 512 / 600 / 720 / 900 / 1000 / 1024
 Other number of pulses on request

TECHNICAL DATA
mechanical

Shaft diameter	6 mm
Absolute max. shaft load	radial 10 N, axial 5 N
Absolute max. speed	10 000 min ⁻¹
Torque	≤ 0.2 Ncm
Protection class (EN 60529)	Housing IP50, bearings IP40
Operating temperature	-10 ... +60 °C
Storage temperature	-25 ... +85 °C
Vibration resistance	100 m/s ² (10 ... 2000 Hz)
Shock resistance	1000 m/s ² (6 ms)
Connection	1.5 m cable, radial ¹
Housing	glassfibre reinforced plastic
Flange	Q = Square flange
Weight	approx. 60 g

¹ Other cable length on request

TECHNICAL DATA
electrical

General design	as per DIN VDE 0160, protection class III, contamination level 2, over voltage class II	
Supply voltage (SELV)	with push-pull (D):	DC 5 V ± 10 %
	with push-pull (K):	DC 5 V ¹ ± 10 % oder DC 10-30 V ¹
Max. current w/o load	40 mA (DC 5 V), 60 mA (DC 10 V), 30 mA (DC 24 V)	
Standard output versions ²	push-pull (K, D):	A, B, N, \bar{A} alarm

¹ Pole protection

² Output description and technical data see chapter "Technical basics"

Economy Types

DIMENSIONAL DRAWINGS

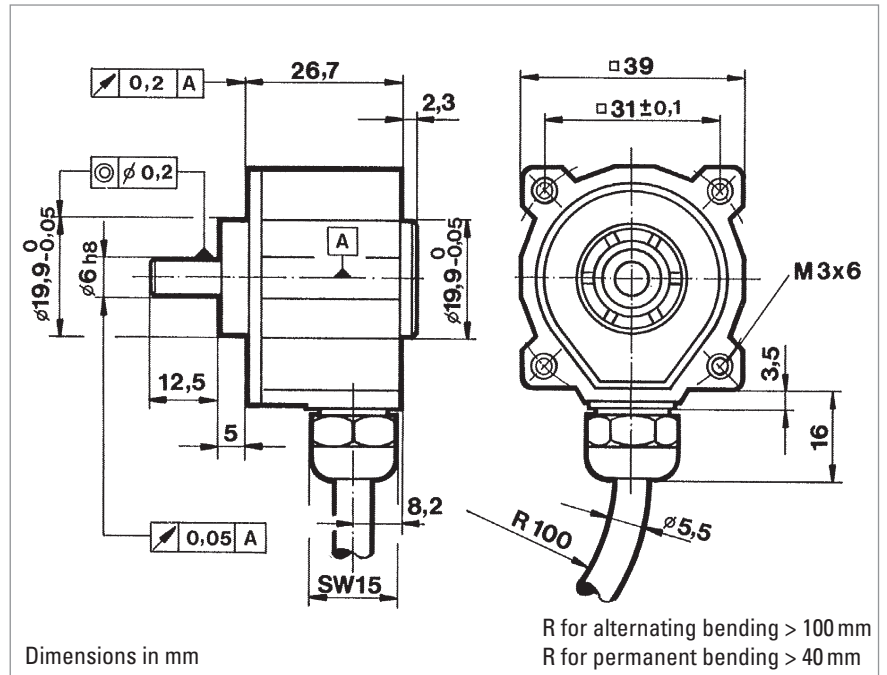

PIN ASSIGNMENT

Description (push-pull)	Lead Ø mm ²	Colour
DC 5 V/10 - 30 V	0.5	red
Channel A	0.14	white
Channel B	0.14	green
Channel N	0.14	yellow
GND	0.5	black
Alarm	0.14	yellow/black

ORDERING INFORMATION

Type	Model	Number of pulses	Supply voltage	Flange, Protection, Shaft	Output	Connection
<input type="checkbox"/>	<input type="checkbox"/>	<input type="text"/>	<input type="checkbox"/>	<input type="text"/>	<input type="checkbox"/>	<input type="checkbox"/>
RI38-	0 Standard	5 ... 1 024	A DC 5 V E DC 10 - 30 V ¹	Q.11 Square, IP40, 6 mm	K push-pull ² short circuit proof D push-pull DC 5 V, ±30 mA	B Cable radial
¹ only with output K ² ±10 mA at DC 5 V, ±30 mA at DC 10 - 30 V						

Economy Types



- Replacement for type RIM
- Economical miniature encoder
- Up to 14 400 steps with 3 600 pulses
- High mechanical efficiency
- Application e.g.
 - wood working machines
 - FHP motors
 - graphic machines
 - table robots

NUMBER OF PULSES

5 / 10 / 20 / 25 / 28 / 32 / 50 / 60 / 72 / 100 / 128 / 144 / 200 / 250 / 256 / 288 / 300 / 360 / 400 / 500 / 512 / 600 / 720 / 900 / 1000 / 1024 / 1250 / 1500 / 2000 / 2048 / 2500 / 3000 / 3600
 Other number of pulses on request

TECHNICAL DATA
mechanical

Shaft diameter	6 mm
Absolute max. shaft load	radial 10 N, axial 5 N
Absolute max. speed	10 000 min ⁻¹
Torque	≤ 0.2 Ncm
Protection class (EN 60529)	Housing IP50, bearings IP40
Operating temperature	-10 ... +70 °C
Storage temperature	-25 ... +85 °C
Vibration resistance (IEC 68-2-6)	100 m/s ² (10 ... 2000 Hz)
Shock resistance (IEC 68-2-27)	1000 m/s ² (6 ms)
Connection	1.5 m cable, radial ¹
Housing	Aluminium
Flange	Pilot flange
Weight approx.	60 g

¹ Other cable length on request

TECHNICAL DATA
electrical

General design	as per DIN VDE 0160, protection class III, contamination level 2, overvoltage class II
Supply voltage (SELV)	with push-pull (D): DC 5 V ±10 % with push-pull (K): DC 5 V ² ±0 % oder DC 10 - 30 V ²
Max. current w/o load	40 mA (DC 5 V), 60 mA (DC 10 V), 30 mA (DC 24 V)
Standard output versions ³	push-pull (K, D): A, B, N, \overline{A} alarm

² Pole protection

³ Output description and technical data see chapter "Technical basics"

Incremental Shaft Encoders Type RI 41

Economy Types

DIMENSIONAL DRAWINGS

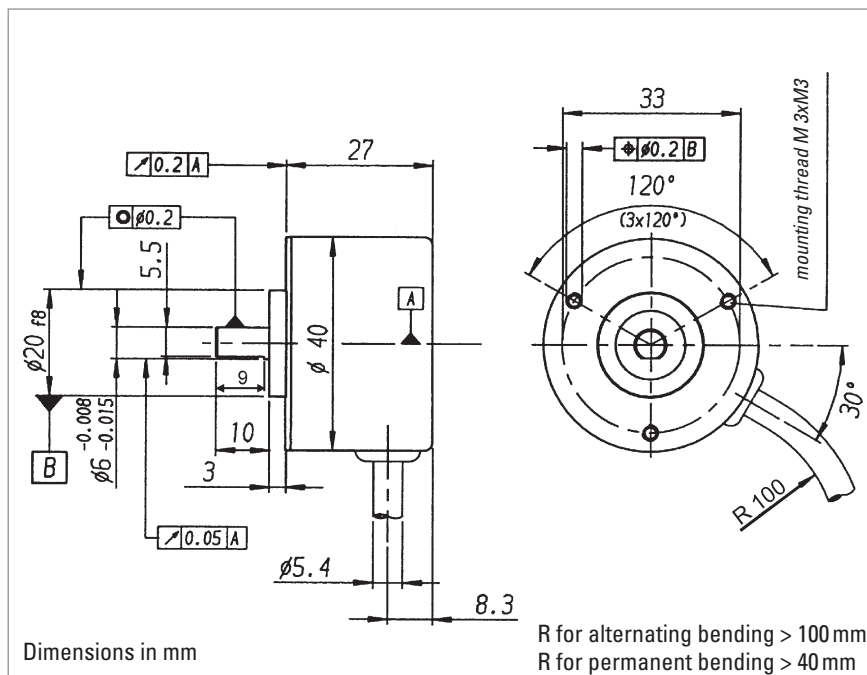

PIN ASSIGNMENT

Description (push-pull)	Lead \varnothing mm ²	Colour
DC 5 V/10 - 30 V	0.5	red
Channel A	0.14	white
Channel B	0.14	green
Channel N	0.14	yellow
GND	0.5	black
Alarm	0.14	yellow/black
screen ¹		screen ¹

¹ not connected with encoder housing

ORDERING INFORMATION

Type	Model	Number of pulses	Supply voltage	Flange, Protection, Shaft	Output	Connection
<input type="checkbox"/>	<input type="checkbox"/>	<input type="text"/>	<input type="checkbox"/>	<input type="text"/>	<input type="checkbox"/>	<input type="checkbox"/>
RI41-	O Standard	5 ... 3600	A DC 5 V E DC 10 - 30 V ¹	R.11 Pilot, IP40, 6 mm	K push-pull ² short circuit proof D push-pull DC 5 V, ± 30 mA	B Cable radial

¹ only with output K
² ± 10 mA at DC 5 V, ± 30 mA at DC 10 - 30 V

Economy Types



- Economy encoder
- High protection IP65
- Push-pull or NPN-O.C.
- Applications, e.g.
 - textile machinery

NUMBER OF PULSES

5 / 10 / 20 / 25 / 28 / 32 / 50 / 60 / 72 / 100 / 128 / 144 / 200 / 250 / 256 / 288 / 300 / 360 / 400 / 500 / 512 / 600 / 720 / 900 / 1000 / 1024
 Other number of pulses on request

TECHNICAL DATA
mechanical

Shaft diameter	6 mm
Absolute max. shaft load	radial 10 N, axial 5 N
Absolute max. speed	10 000 min ⁻¹
Torque	≤ 1 Ncm
Protection class (EN 60529)	Housing IP65, bearings IP64
Operating temperature	0 ... +60 °C
Storage temperature	-25 ... +85 °C
Vibration resistance (IEC 68-2-6)	100 m/s ² (10 ... 2000 Hz)
Shock resistance (IEC 68-2-27)	1000 m/s ² (6 ms)
Connection	1.5 cable axial ¹
Material	Housing: plastic, Flange: aluminium
Flange	Pilot flange
Weight approx.	75 g

¹ Other cable length on request

TECHNICAL DATA
electrical

General design	as per DIN VDE 0160, protection class III, contamination level 2, overvoltage class II
Supply voltage (SELV)	with push-pull (D): DC 5 V ± 10 % with push-pull (K): DC 5 V ¹ ± 10 % oder DC 10 - 30 V ¹ with push-pull complementary (I): DC 10 - 30 V ¹ at NPN-O.C. (S): DC 10 - 24 V ¹
Max. current w/o load	40 mA (DC 5 V), 30 mA (DC 24 V) with push-pull (K,I) 40 mA (DC 24 V), bei NPN-O.C. (S)
Standard output versions	push-pull ² / push-pull complementary ² / NPN-O.C. ³

¹ Pole protection

² Output description and technical data see chapter "Technical basics"

³ NPN-O.C. with internal pull-up resistor = 10 KΩ, max. pulse frequency = 50 KHz, max. output lead = ± 30 mA, tolerance ± 30° electrical, delay time 4μs

Incremental Shaft Encoders Economy Types

Type RI 42

DIMENSIONAL DRAWINGS

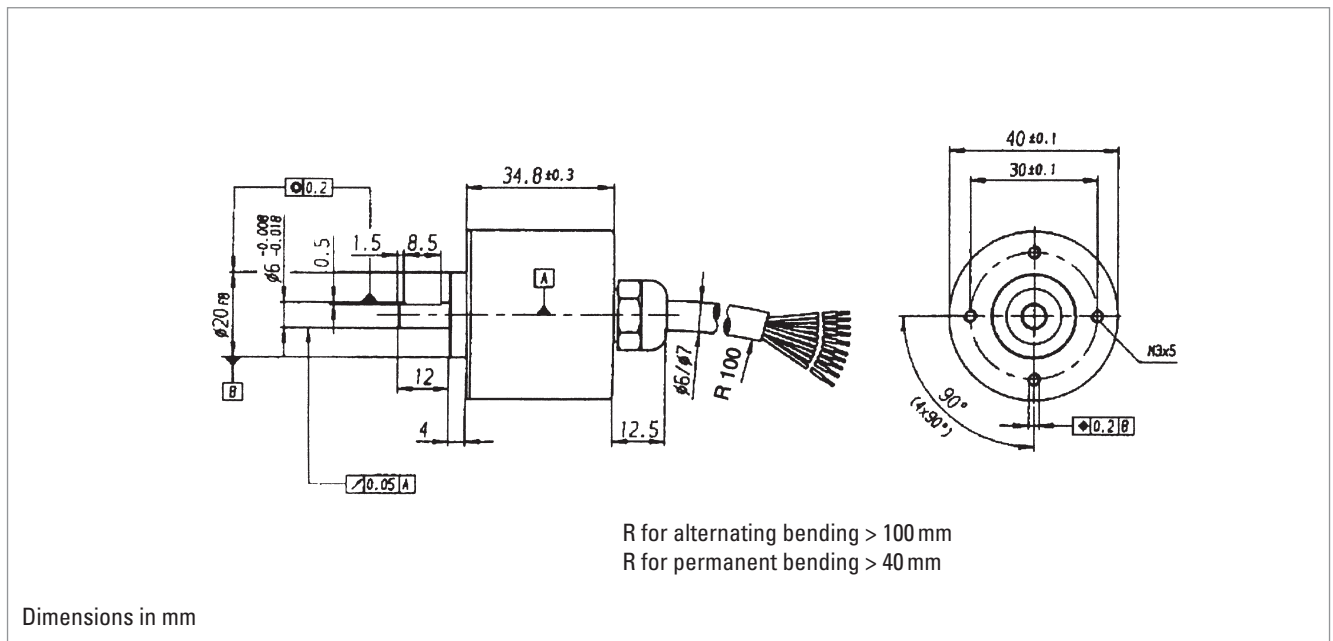

PIN ASSIGNMENT

Colour (PVC)	Output circuit push-pull (K, D), Open Collector (S)	push-pull complementary (I)
white	Channel A	Channel A
white/brown		Channel \bar{A}
green	Channel B	Channel B
green/brown		Channel \bar{B}
yellow	Channel N	Channel N
yellow/brown		Channel \bar{N}
yellow/black	Alarm	Alarm
yellow/red		Sense V_{CC}
red	DC 5/10 - 30/10 - 24 V	DC 10 - 30 V
black	GND	GND

ORDERING INFORMATION

Type	Model	Number of pulses	Supply voltage	Flange, Protection, Shaft	Output	Connection
<input type="checkbox"/>	<input type="checkbox"/>	<input type="checkbox"/>	<input type="checkbox"/>	<input type="checkbox"/>	<input type="checkbox"/>	<input type="checkbox"/>
RI42-	0 Standard	5 ... 1 024	A DC 5 V ¹ E DC 10 - 30 V ² C DC 10 - 24 V ³	R.41 Pilot, IP64, 6 mm	K push-pull ⁴ short circuit proof D push-pull DC 5 V, ± 30 mA S Open Collector NPN I push-pull complementary	A Cable axial
¹ only with output K, D ² only with output K, I ³ only with output S ⁴ ±10 mA at DC 5 V, ±30 mA at DC 10 - 30 V						

Incremental Shaft Encoders Type RX 70/71

Explosion-proof encoders



RX 70



RX 71

Stainless steel

- Encoder for explosion group II
- Highest working reliability
- Application e.g.:
 - enamelling production lines
 - surfacing machines
 - bottling machines
 - mixers
 - silo works
- For absolute explosion-proof encoders, see "Absolute Encoders Type AX 70 / 71"



ATEX

NUMBER OF PULSES

1 / 2 / 3 / 4 / 5 / 10 / 15 / 20 / 25 / 30 / 35 / 40 / 45 / 50 / 60 / 64 / 70 / 72 / 80 / 100 / 125 / 128 / 144 / 150 / 180 / 200 / 230 / 250 / 256 / 300 / 314 / 350 / 360 / 375 / 400 / 460 / 480 / 500 / 512 / 600 / 625 / 635 / 720 / 750 / 900 / 1000 / 1024 / 1200 / 1250 / 1500 / 1600 / 1800 / 2000 / 2048 / 2500 / 3000 / 3480 / 3600 / 3750 / 3968 / 4000 / 4096 / 4800 / 5000 / 5400 / 6000 / 7200 / 7680 / 8000 / 8192 / 9000 / 10000

Other number of pulses on request

EX-CLASSIFICATION

The incremental shaft encoder is available in explosion proof design with explosion proof enclosure "d" under RX 70 and RX 71 (stainless steel). The PTB has assured with the Declaration of Conformity that the RX 70 / 71 meets the requirements of safety and health according to EN 50014 and EN 50018. Therefore it is approved in explosive areas, code „Ex II 2 G/D E Ex d II C T4/T6 IP65/ IP66 135°C resp. 85°C“. For applications under tough environmental conditions and food industry the stainless steel version RX 71 is available.

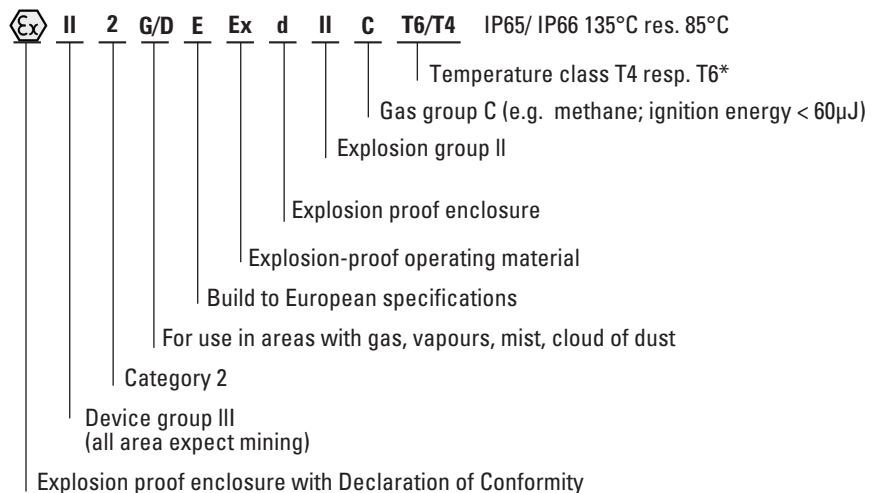

T6 = Highest permissible surface temperature +85°C (max. speed = 6000 U/min⁻¹)
 T4 = Highest permissible surface temperature +130°C (max. speed = 10000 U/min⁻¹)

Incremental Shaft Encoders Type RX 70/71

Explosion-proof encoders

TECHNICAL DATA mechanical

Shaft diameter	10 mm
Absolute max. shaft load	radial 100 N, axial 40 N
Absolute max. speed	10 000 min ⁻¹ (EEx d IIC T4), 6 000 min ⁻¹ (EEx d IIC T6)
Torque	≤ 1 Ncm
Moment of inertia	approx. 20 gcm ²
Protection class (EN 60529)	Housing IP65, bearings IP64
Operating temperature	-10 ... +40 °C (EEx d IIC T6) -20 ... +60 °C (EEx d IIC T4)
Storage temperature	-25 ... +85 °C
Vibration resistance (IEC 68-2-6)	10 g = 100 m/s ² (10...2000 Hz)
Shock resistance (IEC 68-2-27)	100 g = 1000 m/s ² (6 ms)
Connection	5 m cable axial ¹ for fixed layout
Size	Ø 70 mm
Flange	Clamping flange, Bohrungen 3 x M6
Weight approx.	1400 g

¹ Other cable length on request

TECHNICAL DATA electrical

General design	as per DIN VDE 0160, protection class III, Contamination level 2, over voltage level II	
Supply voltage (SELV)	with RS 422 + Sense (T): DC 5V ± 10 % with RS 422 + Alarm (R): DC 5V ± 10 % oder DC 10 - 30 V ¹ with push-pull (K, I): DC 10 - 30 V ¹	
Max. current w/o load	40 mA (DC 5V), 60 mA (DC 10V), 30 mA (DC 24V)	
Standard output versions ²	RS 422 (R):	A, B, N, \bar{A} , \bar{B} , \bar{N} , Alarm
	RS 422 (T):	A, B, N, \bar{A} , \bar{B} , \bar{N} , Sense
	push-pull (K):	A, B, N, Alarm
	push-pull complementary (I):	A, B, N, \bar{A} , \bar{B} , \bar{N} , Alarm

¹ Pole protection with supply voltage DC 10 - 30 V

² Output description and technical data see chapter "Technical basics"

DIMENSIONAL DRAWINGS

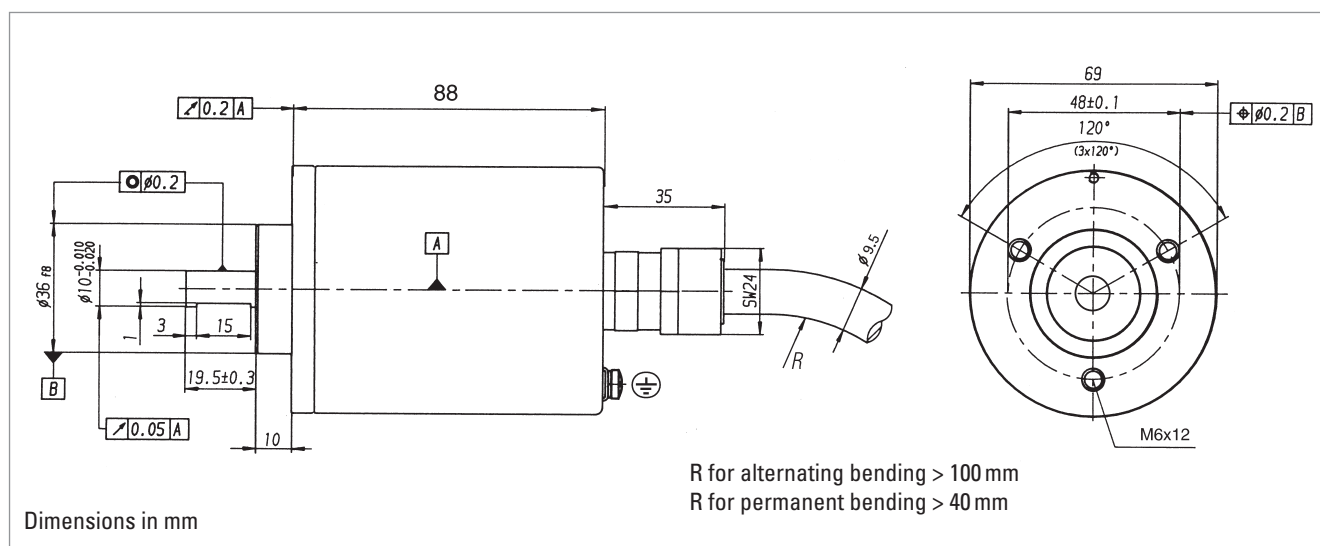

Incremental Shaft Encoders Type RX 70/71

Explosion-proof encoders

PIN ASSIGNMENT

Cable Colour	No.	Output			
		RS 422+ Sense (T)	RS 422+ Alarm (R)	push-pull (K)	push-pull complementary (I)
brown/green	12	DC 5 V	DC 5/10 - 30 V	DC 10 - 30 V	DC 10 - 30 V
white/green	11	GND	GND	GND	GND
blue	10	Sense V _{CC}			
white	9	Sense GND			
brown	1	Channel A	Channel A	Channel A	Channel A
green	2	Channel \bar{A}	Channel \bar{A}		Channel \bar{A}
grey	3	Channel B	Channel B	Channel B	Channel B
pink	4	Channel \bar{B}	Channel \bar{B}		Channel \bar{B}
red	5	Channel N	Channel N	Channel N	Channel N
black	6	Channel \bar{N}	Channel \bar{N}		Channel \bar{N}
violet	7		Alarm	Alarm	Alarm
screen			Cable screen connected to housing		
Screw terminal			for additional connection of an earth conductor		

ORDERING INFORMATION

Type	Model	Number of pulses	Supply voltage	Flange, Protection, Shaft	Output	Connection
<input type="checkbox"/>	<input type="checkbox"/>	<input type="text"/>	<input type="checkbox"/>	<input type="text"/>	<input type="checkbox"/>	<input type="checkbox"/>
RX70-T	I Incremental	1 ... 10 000	A DC 5 V ¹ E DC 10-30 V ²	K.42 Clamping, IP64, 10 mm	K push-pull short circuit proof T RS 422 + Sense I push-pull complementary R RS 422 + Alarm	A PVC cable axial (5m)
¹ with output T, R ² with output K, I, R						

Type	Model	Number of pulses	Supply voltage	Flange, Protection, Shaft	Output	Connection
<input type="checkbox"/>	<input type="checkbox"/>	<input type="text"/>	<input type="checkbox"/>	<input type="text"/>	<input type="checkbox"/>	<input type="checkbox"/>
RX71-T Stainless steel	I Incremental	1 ... 10 000 increments	A DC 5 V ¹ E DC 10-30 V ²	K.42 Clamping, IP64, 10 mm	K push-pull short circuit proof T RS 422 + Sense I push-pull complementary R RS 422 + Alarm	A PVC cable axial (5m)
¹ with output T, R ² with output K, I, R						

Stainless steel encoders

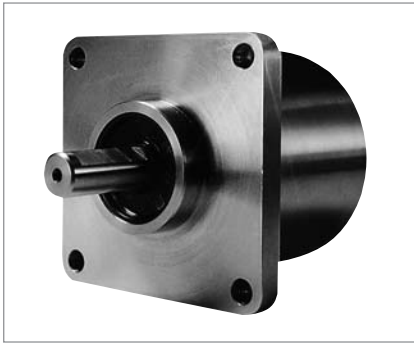

- Stainless steel encoder with high protection class
- High corrosion resistance
- Use in the area of food production or if sea-water proof is required
- Application e.g.:
 - packing machines
 - bottling machines
 - washing plants
 - mixers
 - cranes
 - hoists
 - marine outfitters

NUMBER OF PULSES

1 / 2 / 3 / 4 / 5 / 10 / 15 / 20 / 25 / 30 / 35 / 40 / 45 / 50 / 60 / 64 / 70 / 72 / 80 / **100** / 125 / 128 / 144 / 150 / 180 / 200 / 230 / **250** / 256 / 300 / 314 / 350 / 360 / 375 / 400 / 460 / 480 / **500** / 512 / 600 / 625 / 635 / 720 / 750 / 900 / **1000** / **1024** / 1200 / **1250** / 1500 / 1600 / 1800 / 2000 / 2048 / **2500** / 3000 / 3480 / **3600** / 3750 / 3968 / 4000 / **4096** / 4800 / **5000** / 5400 / 6000 / 7200 / 7680 / 8000 / 8192 / 9000 / 10000

Other number of pulses on request

Preferably available versions are printed in bold type.

TECHNICAL DATA mechanical

Shaft diameter	9.52 mm / 10 mm
Absolute max. shaft load	radial 60 N / axial 40 N
Absolute max. speed	10 000 min ⁻¹
Torque	≤ 1 Ncm
Moment of inertia	approx. 20 gcm ²
Protection class (EN 60529)	Housing IP67, bearings IP67
Operating temperature	-10 ... +70 °C
Storage temperature	-25 ... +85 °C
Vibration resistance (IEC 68-2-6)	100 m/s ² (10 ... 2000 Hz)
Shock resistance (IEC 68-2-27)	1000 m/s ² (6 ms)
Connection	1.5 m cable ¹ radial or axial
Housing	Stainless steel Ø 58 mm
Flange	Q=Square flange 63.5 x 63.5 mm
Weight approx.	620 g

¹ Other cable length on request

TECHNICAL DATA electrical

General design	as per DIN VDE 0160, protection class III, Contamination level 2, over voltage level II	
Supply voltage (SELV)	with RS 422 + Sense (T):	DC 5 V ± 10 %
	with RS 422 + Alarm (R):	DC 5 V ± 10 % oder DC 10 - 30 V ²
	with push-pull (K, I):	DC 10 - 30 V ²
Max. current w/o load	40 mA (DC 5 V), 60 mA (DC 10 V), 30 mA (DC 24 V)	
Standard output versions ³	RS 422 (R):	A, B, N, \overline{A} , \overline{B} , \overline{N} , \overline{Alarm}
	RS 422 (T):	A, B, N, \overline{A} , \overline{B} , \overline{N} , Sense
	push-pull (K):	A, B, N, \overline{Alarm}
	push-pull complementary (I):	A, B, N, \overline{A} , \overline{B} , \overline{N} , \overline{Alarm}

² Pole protection with supply voltage DC 10 - 30 V

³ Output description and technical data see chapter "Technical basics"

Incremental Shaft Encoders

Stainless steel encoders

Type RI 59

DIMENSIONAL DRAWINGS

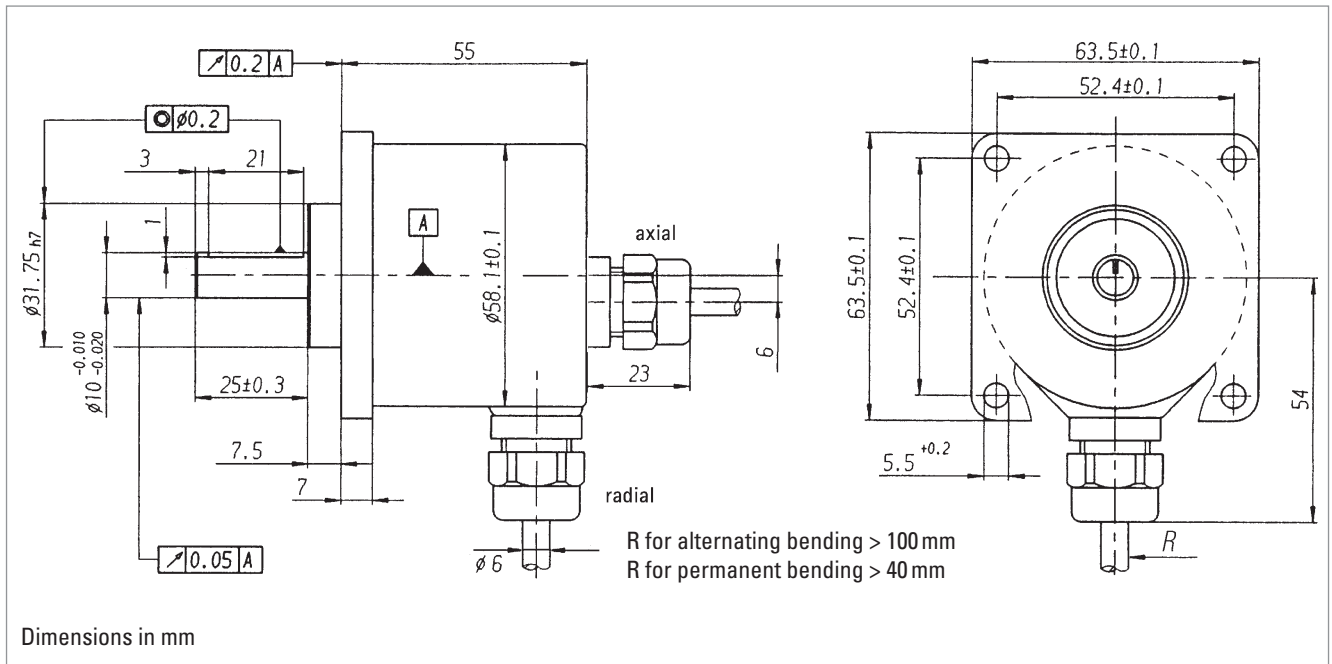

PIN ASSIGNMENT

Connecting cable		Output	
Colour	Lead Ø mm ²	RS 422 T and R	push-pull K and I
red	0.5	DC 5/10 - 30 V	DC 10 - 30 V
red/yellow	0.14	Sense V _{CC}	Sense V _{CC}
white	0.14	Channel A	Channel A
white/brown	0.14	Channel \bar{A}	Channel \bar{A} ¹
green	0.14	Channel B	Channel B
green/brown	0.14	Channel \bar{B}	Channel \bar{B} ¹
yellow	0.14	Channel N	Channel N
yellow/brown	0.14	Channel \bar{N}	Channel \bar{N} ¹
black	0.5	GND	GND
black/yellow	0.14	Alarm /Sense GND ²	Alarm
screen ³		screen ³	screen ³

¹ only push-pull complementary (I)

² depending on ordering code

³ connected with encoder housing

ORDERING INFORMATION

Type	Model	Number of pulses	Supply voltage	Flange, Protection, Shaft	Output	Connection
RI59-	0 Standard	1 ... 10 000	A DC 5 V E DC 10 - 30 V	Q.7A Square 63.5 x 63.5, IP67, 10 mm x 25 Q.7B Square 63.5 x 63.5, IP67, 9.52 mm x 25	T RS 422 + Sense K push-pull short circuit proof I push-pull complementary R RS 422 + Alarm	A PVC cable axial B PVC cable radial

Sine-wave encoders



- Harmonic distortion less than 1 %
- Extended temperature range, -40 ° to +100 °C
- 500 kHz sine-wave incremental signal frequency response
- All accessible components, including the electrical connections, are resistant to common industrial coolants and lubricants
- Self-monitoring and error compensation
- Secure against short-circuit and overload
- Hot plug
- Unit is protected against overloads of 10 V/50 ms
- 6 x 10 mm solid shaft

TECHNICAL DATA mechanical

	RIS 58-0 with solid shaft
Protection bearings	IP64 (IP67 on request)
Protection housing	IP65 (IP67 on request)
Shaft diameter	6 mm
Absolute max. speed	12 000 min ⁻¹
Torque	≤ 1 Ncm
Absolute max. shaft load	axial 40N / radial 60N
Operating temperature	-40 ... +100 °C
Storage temperature	-20 ... +80 °C
Weight approx.	265 g
Vibration resistance (IEC 68-2-6)	100 m/s ² (10 ... 2 000 Hz)
Shock resistance (IEC 68-2-27)	1 000 m/s ² (6 ms)

TECHNICAL DATA electrical

General design	as per DIN EN 61010-1, protection class III, Contamination level 2, over voltage level III
Supply voltage	DC 5 V ±10 % (SELV)
Max. current w/o load	max. 120 mA
Incremental signal	Sine - Cosine 1 Vpp
Number of pulses	1 000, 1 024, 2 048, 2 500 (other number of pulses on request)
Absolute accuracy	±35"
Repeatability	±7"
Max. frequency	500 kHz
Reference signal	> 0.4 V (1 pulse/revolution)
Connection	Cable or conin, axial or radial

Incremental Shaft Encoders Type RIS 58-0

Sine-wave encoders

DIMENSIONAL DRAWINGS RIS 58-0 with solid shaft

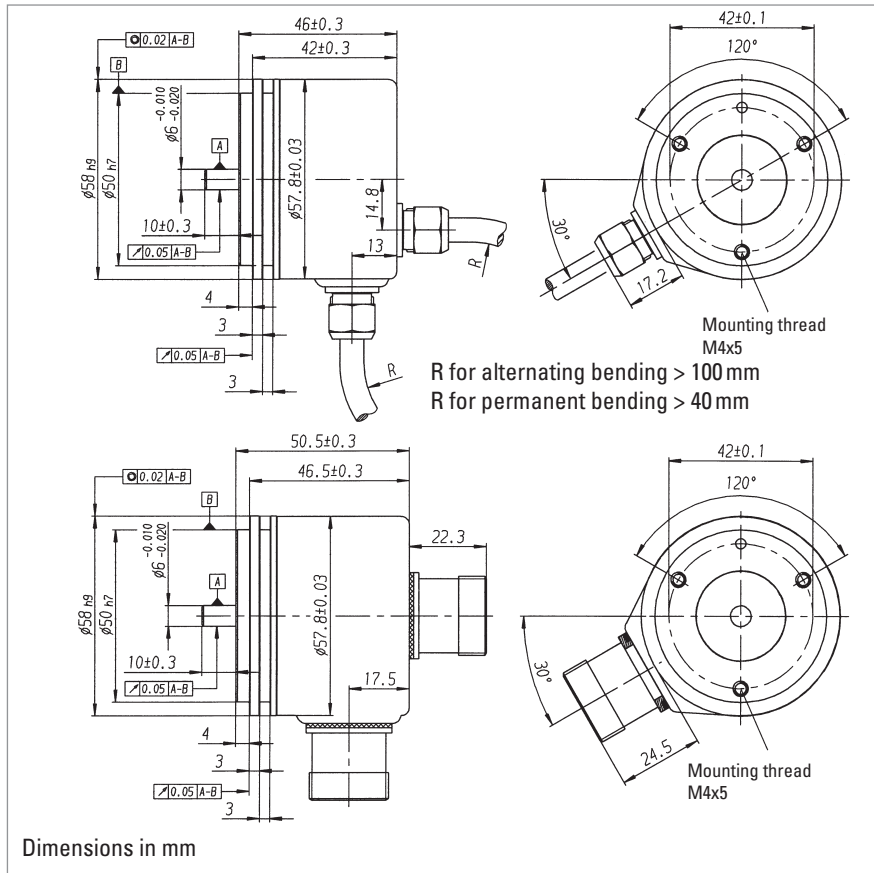

PIN ASSIGNMENT

Signal	Conin 12 pole	TPE cable
+5 V	12	brown/green
0 V	10	white/green
A+	5	brown
A-	6	green
B+	8	grey
B-	1	pink
R+	3	red
R-	4	black
+5 V Sense	2	blue
N. C.	7	violet
N. C.	9	-
0V Sense	11	white
Housing	screen	screen

ORDERING INFORMATION

Type	Model	Number of pulses	Supply voltage	Flange, Protection, Shaft	Output	Connection
<input type="checkbox"/>	<input type="checkbox"/>	<input type="text"/>	<input type="checkbox"/>	<input type="text"/>	<input type="checkbox"/>	<input type="checkbox"/>
RIS58-	0 Standard	1 000 1 024 2 048 2 500	A DC 5 V	S.41 Synchro , IP64, 6 mm	V SinCos	A TPE cable axial B TPE cable radial G Conin connector axial, 12 pin male, ccw H Conin connector radial, 12 pin male, ccw

Incremental Shaft Encoders Type RIS 58-H

Sine-wave encoders



- Harmonic distortion less than 1 %
- Extended temperature range, -40 ° to +100 °C
- 500 kHz sine-wave incremental signal frequency response
- All accessible components, including the electrical connections, are resistant to common industrial coolants and lubricants
- Self-monitoring and error compensation
- Secure against short-circuit and overload
- Hot plug
- Unit is protected against overloads of DC 10 V/50 ms
- 10 or 12 mm one sided open hub shaft with stator coupling

TECHNICAL DATA mechanical

	RIS 58-H with hollow shaft
Protection bearings	IP64
Protection housing	IP65
Shaft diameter	10 mm, 12 mm
Max. speed	12 000 min ⁻¹
Starting torque	< 1 Ncm
Torque support	
Axial compensations range	±1.5 mm
Radial compensations range	±0.2 mm
Operating temperature	-40 ... +100 °C
Storage temperature	-20 ... +80 °C
Weight approx.	270 g
Vibration resistance (IEC 68-2-6)	100 m/s ² (10 ... 2 000 Hz)
Shock resistance (IEC 68-2-27)	1 000 m/s ² (6 ms)

TECHNICAL DATA electrical

General design	as per DIN EN 61010-1, protection class III, Contamination level 2, over voltage level III
Supply voltage	DC 5 V ±10 % (SELV)
Max. current w/o load	max. 120 mA
Incremental signal	Sine - Cosine 1 Vpp
Number of pulses	1 000, 1 024, 2 048 (other number of pulses on request)
Absolute accuracy	±35"
Repeatability	±7"
Max. frequency	500 kHz
Reference signal	> 0.4 V (1 pulse/revolution)
Connection	TPE cable or conin, axial or radial

Incremental Shaft Encoders Type RIS 58-H

Sine-wave encoders

DIMENSIONAL DRAWINGS RIS 58-H with hollow shaft

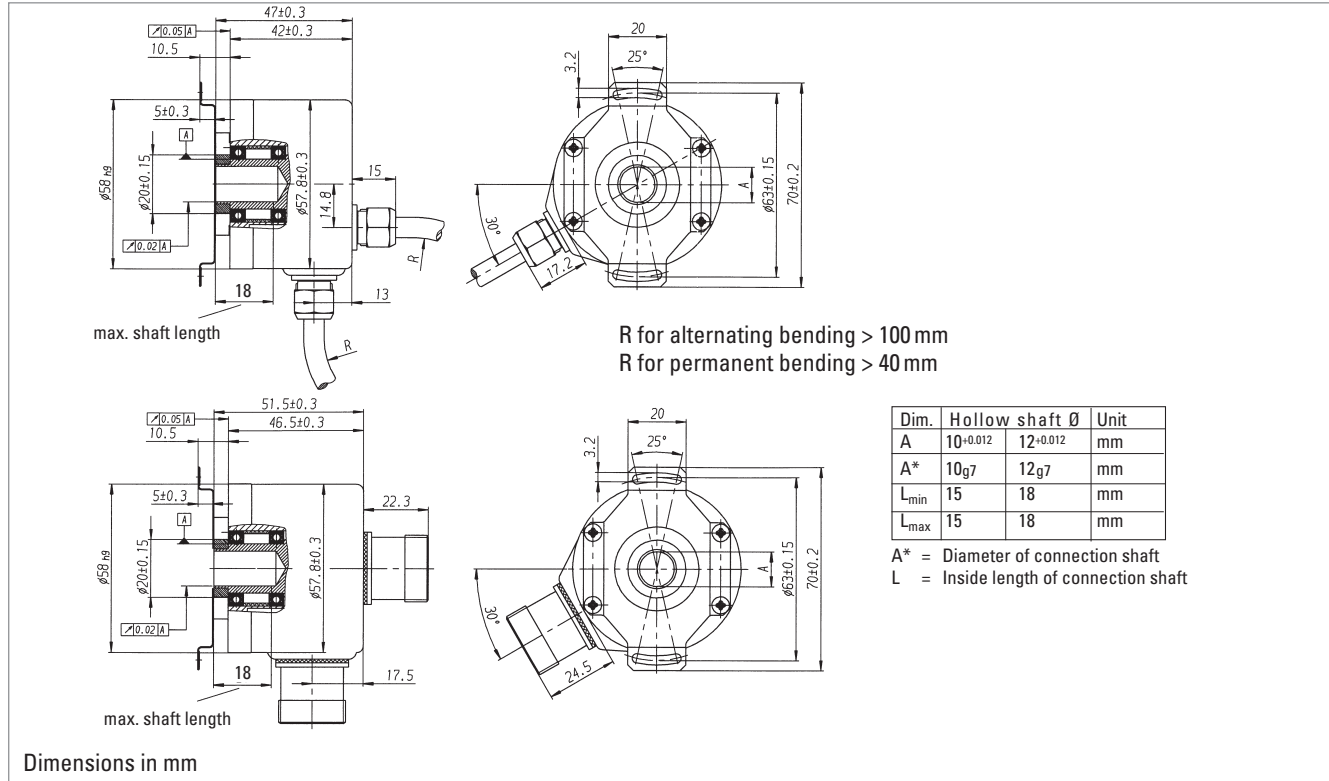

PIN ASSIGNMENT

Signal	Conin 12 pole	TPE cable
+ DC 5 V	12	brown/green
0 V	10	white/green
A+	5	brown
A-	6	green
B+	8	grey
B-	1	pink
R+	3	red
R-	4	black
+ DC 5 V Sense	2	blue
N. C.	7	violet
N. C.	9	-
0V Sense	11	white
Housing	screen	screen

ORDERING INFORMATION

Type	Model	Number of pulses	Supply voltage	Flange, Protection, Shaft	Output	Connection
<input type="checkbox"/>	<input type="checkbox"/>	<input type="checkbox"/>	<input type="checkbox"/>	<input type="checkbox"/>	<input type="checkbox"/>	<input type="checkbox"/>
RIS58-	H Hollow shaft	1 000 1 024 2 048	A DC 5 V	F.42 Hubshaft with tether, IP64, 10 mm F.47 Hubshaft with tether, IP64, 12 mm	V SinCos	A TPE cable axial B TPE cable radial G Conin connector axial, 12 pin male, ccw H Conin connector radial, 12 pin male, ccw

Absolute Shaft Encoders



Absolute shaft encoders, also known as shaft-angle encoders, are by no means used only to detect angular positions. They are also suitable for linear movements that can be converted into rotary movements by a toothed belt, drive pinion, or wire winch.

The special feature of absolute shaft encoders is that they assign a unique, digitally encoded signal to each individual measured increment. The method of transducing prevents erroneous readings, whether by a power failure, or by a transient malfunction. After the encoder is switched on again, or power is restored, the position can be read out. It is not necessary to move to a reference position, as it is for shaft encoders of the incremental type.

Examples of application for absolute encoders

- overhead support robots
- ventilation flaps
- spinning machines
- conveyor belts
- cam controllers
- injection moulding machines
- packaging machinery
- extruders
- folding machines
- printing machines
- high lift storage systems
- stamping machines

Absolute Shaft Encoders - ACURO industry

AC 36 - BiSS / SSI

Special Features

- Compact design for single or multiturn
- Interfaces: standard SSI, expanded SSI mode or BiSS
- Use of sine / cosine signals for fast control tasks possible



Type	AC36 - BiSS / SSI
Technical Data - mechanical	(preliminary)
Housing diameter	37.5 mm
Protection class shaft input	IP64
Protection class housing	IP64
Flange	pilot flange
Shaft diameter	6 mm
Max. speed	Continuous: 10 000 min ⁻¹ , Short term: 12 000 min ⁻¹
Starting Torque	0,01 Nm
Moment of inertia	2.5 x 10 ⁻⁶ kgm ²
Spring tether (hollow shaft)	
Tolerance axial / radial	± 0.5 mm/ ± 0.05 mm
Shock resistance DIN EN 60068-2-27	1 000 m/s ² (6 ms)
Vibration resistance DIN EN 60068-2-6	100 m/s ² (10 ... 2 000 Hz)
Operating temperature	-25 ... +100 °C
Storage temperature	-15 ... +85 °C (because of packing)
Weight approx. ST/MT	80 g / 130 g
Technical Data - electrical	(preliminary)
Supply voltage	DC 5 V, -5 % / + 10 %
Max. current w/o load ST/MT	50 mA / 100 mA
Interface	BiSS or Standard SSI
Lines / Drives	Clock and Data / RS422
Output code	Gray or Binary
Resolution singleturn	13 Bit ... max. 17 Bit
Resolution multiturn	12 Bit
Incremental signals	Sine - Cosine 1 Vpp
Number of pulses	2048
3 dB limiting frequency	500 kHz
Alarm output	Alarm bit (SSI option), warning bit and alarm bit (BiSS)
Connection	Cable axial or radial
Page	109

Absolute Shaft Encoders - ACURO industry

AC 58 - BiSS / SSI, Parallel

Special Features

- Compact design for single or multiturn
- Aids for start-up and operation: diagnostic LED, preset key with optical response
- Interfaces: standard SSI, expanded SSI mode or BiSS
- Use of sine / cosine signals for fast control tasks possible



Type	AC 58 - BiSS / SSI	AC 58 - Parallel
Technical Data - mechanical		
Housing diameter	58 mm	58 mm
Protection class shaft input	IP64 or IP67	IP64 or IP67
Protection class housing	IP64 (IP67 optional)	IP64 (IP67 optional)
Flange	Synchro flange, clamping flange, hubshaft with tether, square flange	Synchro flange, clamping flange, hubshaft with tether, square flange
Shaft diameter	Solid shaft 6 mm, 10 mm; Hub shaft 10 mm, 12 mm	Solid shaft 6 mm, 10 mm; Hub shaft 10 mm, 12 mm
Max. speed	Continuous: 10 000 min ⁻¹ , Short term: 12 000 min ⁻¹	Continuous: 10 000 min ⁻¹ , Short term: 12 000 min ⁻¹
Shaft load	axial 40 N / radial 60 N	axial 40 N / radial 60 N
Operating temperature	-40 ... 100 °C	-40 ... 100 °C
Weight approx. ST/MT	260 g / 310 g	350 g / 400 g
Technical Data - electrical		
Supply voltage	DC 5 V, -5 % / + 10 % or DC 10 - 30 V	DC 10 - 30 V
Max. current w/o load ST/MT	50 mA / 100 mA	200 mA / 300 mA
Interface	BiSS or Standard SSI	Parallel
Resolution singleturn	10-17 Bit, Gray Excess: 360, 720 steps	10-14 Bit, Gray Excess: 360, 720 steps
Resolution multi turn	12 Bit	12 Bit
Optional incremental signals	Sine - Cosine 1 Vpp	
Number of pulses	2048	
Absolute accuracy	±35"	
Repeat accuracy	±7"	
Parameterization	Code type, direction of rotation, warning, alarm	
Control input	Direction	ST: <u>L</u> atch, <u>D</u> irection, <u>T</u> ristate MT: Tristate
Reset key	Latch via parameterization	only with MT
Alarm output	Alarm bit (SSI option), warning bit and alarm bit (BiSS)	NPN o.c. max. 5 mA
Status LED	Green = OK.; red = alarm	Green = OK.; red = alarm
Connection	Cable axial or radial Conin axial or radial M12, 8 pole	Cable axial or radial 17 pole Conin axial or radial 37 pole Sub-D
Page	113	118

Absolute Shaft Encoders - ACURO industry

AC 58 with Fieldbus Interfaces

Special Features

- Overall length: 63 mm for singleturn, 73 mm for multiturn, including bus cover
- The complete bus specific electronics is integrated in the connection cover
- Option: Display "tico"
- Diagnostic LEDs in the bus cover



Type	AC 58 - Profibus	AC 58 - CANopen	AC 58 - CANLayer 2
Technical Data - mechanical			
Housing diameter	58 mm	58 mm	58 mm
Protection class shaft input	IP64 or IP67	IP64 or IP67	IP64 or IP67
Protection class housing	IP67	Bus cover: IP67 Conin, cable: IP64 (IP67 optional)	Bus cover: IP67 Conin, cable: IP64 (IP67 optional)
Flange	Synchro flange, clamping flange, hubshaft with tether, square flange	Synchro flange, clamping flange, hubshaft with tether, square flange	Synchro flange, clamping flange, hubshaft with tether, square flange
Shaft diameter	Solid shaft 6 mm, 10 mm; Hub shaft 10 mm, 12 mm	Solid shaft 6 mm, 10 mm; Hub shaft 10 mm, 12 mm	Solid shaft 6 mm, 10 mm; Hub shaft 10 mm, 12 mm
Max. speed	Continuous: 10 000 min ⁻¹ , Short term: 12 000 min ⁻¹	Continuous: 10 000 min ⁻¹ , Short term: 12 000 min ⁻¹	Continuous: 10 000 min ⁻¹ , Short term: 12 000 min ⁻¹
Shaft load	axial 40 N / radial 60 N	axial 40 N / radial 60 N	axial 40 N / radial 60 N
Operating temperature	-40 ... 85 °C	-40 ... 85 °C	-40 ... 85 °C
Weight approx. ST/MT	350 g / 400 g	350 g / 400 g	350 g / 400 g
Technical Data - electrical			
Supply voltage	DC 10 - 30 V	DC 10 - 30 V	DC 10 - 30 V
Max. current w/o load ST/MT	220 mA / 250 mA	220 mA / 250 mA	220 mA / 250 mA
Interface	RS 485	CAN High-Speed according ISO/DIS 11898	CAN High-Speed according ISO/DIS 11898
Profile / Protocol	Profibus DP with encoder profile Class C2 (parameterizable)	CANopen accord. DS 301 with encoder profile DSP 406	CAN 2.0 A
Programmable	Resolution, preset, direction	Resolution, preset, direction	Direction, limit values
Output code	Binary	Binary	Binary
Transfer mode		Poll mode (only on request), Change of State (automatic if value changes), cyclical with adjustable cycle timer	Poll mode (only on request), Change of State (automatic if value changes), cyclical with adjustable cycle timer
Baud rate	is automatically set within a range of 9,6 Kbaud through 12 Mbaud	set via DIP switch within a range of 10 trough 1000 Kbit/s	set via DIP switch within a range of 10 trough 1000 Kbit/s
Resolution singleturn	10-14 Bit	10-14 Bit	10-14 Bit
Resolution multiturn	12 Bit	12 Bit	12 Bit
Integrated special functions	speed, acceleration, operating time	speed, acceleration, round axis, limit values	
Connection	Bus cover with: <ul style="list-style-type: none"> • 3 M12 connectors • 3 sealed cable exits • double conin 12 pole radial cw • 4 pole M12 f. "tico" display + 2 sealed cable exits 	Bus cover with: <ul style="list-style-type: none"> • 3 sealed cable exits • double conin 9 pole radial cw Cable radial or axial Conin radial or axial, cw or ccw	Bus cover with: <ul style="list-style-type: none"> • 3 sealed cable exits • double conin connectors 9 pole radial cw Cable radial or axial Conin radial or axial, cw or ccw
Page	123	127	130

Absolute Shaft Encoders - ACURO industry

AC 58 with Fieldbus Interfaces

Special Features

- Overall length: 63 mm for singleturn, 73 mm for multiturn, including bus cover
- The complete bus specific electronics is integrated in the connection cover
- Option: Display "tico"
- DiagnosticLEDs in the bus cover



Type	AC 58 - DeviceNet	AC 58 - Interbus	AC 58 - SUCOnet
Technical Data - mechanical			
Housing diameter	58 mm	58 mm	58 mm
Protection class shaft input	IP64 or IP67	IP64 or IP67	IP64 or IP67
Protection class housing	IP67	Bus cover: IP67 Cable: IP64 (IP67 optional)	IP64
Flange	Synchro flange, clamping flange, hubshaft with tether, square flange	Synchro flange, clamping flange, hubshaft with tether, square flange	Synchro flange, clamping flange, hubshaft with tether, square flange
Shaft diameter	Solid shaft 6 mm, 10 mm; Hub shaft 10 mm, 12 mm	Solid shaft 6 mm, 10 mm; Hub shaft 10 mm, 12 mm	Solid shaft 6 mm, 10 mm; Hub shaft 10 mm, 12 mm
Max. speed	Continuous: 10 000 min ⁻¹ , Short term: 12 000 min ⁻¹	Continuous: 10 000 min ⁻¹ , Short term: 12 000 min ⁻¹	Continuous: 10 000 min ⁻¹ , Short term: 12 000 min ⁻¹
Shaft load	axial 40 N / radial 60 N	axial 40 N / radial 60 N	axial 40 N / radial 60 N
Operating temperature	-40 ... 85 °C	-40 ... 70 °C	-10 ... 60 °C
Weight approx. ST/MT	350 g / 400 g	350 g / 400 g	260 g / 310 g
Technical Data - electrical			
Supply voltage	DC 10 - 30 V	DC 10-30 V	DC 10-30 V
Max. current w/o load ST/MT	220 mA / 250 mA	220 mA / 250 mA	220 mA
Interface	CAN High-Speed according ISO/DIS 11898, CAN-Specification 2.0 A (11-Bit-Identifier)	Remote installation bus Interbus, ENCOM Profile K3 (parameterizable), K2	RS485
Profile / Protocol	DeviceNet nach Rev. 2.0, programmable encoder	K3 = ID-Code 37 K2 = ID-Code 36	SUCOnet-K1 or Hengstler-G1-Protocol
Programmable	Resolution, preset, direction	Direction, scaling factor, preset, offset	
Output code	Binary	32 Bit binary	Binary
Transfer mode	Poll mode (only on request), Change of State (automatic if value changes), cyclical with adjustable cycle timer		
Baud rate	set via DIP switches to 125, 250, 500 KBaud	500 KBaud according ENCOM	
Resolution singleturn	10-14 Bit	10-12 Bit	10 - 13 Bit
Resolution multiturn	12 Bit	12 Bit	12 Bit
Connection	Bus cover with: <ul style="list-style-type: none"> • 2 sealed cable exits • 4 pole M12 f. "tico" display + 2 sealed cable exits • 5 pole M12 	Bus cover with: <ul style="list-style-type: none"> • 3 sealed cable exits • 4 pole M12 f. "tico" Display + 2 sealed cable exits • double conin 9 pole Cable 12 pole, radial and axial 	Cable axial/ radial
Page	133	136	140

Absolute Shaft Encoders - ACURO industry

AC 58 - SSI programmable

Special Features

- Compact design: 59mm length for single or multiturn
- Aids for start-up and operation: diagnostic LED, preset key with optical response
- Parameterization: resolution, code type, sense of rotation, output format, warning, alarm
- Parameters can be stored in a non-volatile memory



Type	AC 58 - SSI Programmable
Technical Data - mechanical	
Housing diameter	58 mm
Protection class shaft input	IP64 or IP67
Protection class housing	IP64 (IP67 optional)
Flange	Synchro flange, clamping flange, hubshaft with tether, square flange
Shaft diameter	Solid shaft 6 mm, 10 mm; Hub shaft 10 mm, 12 mm
Max. speed	Continuous: 10 000 min ⁻¹ , Short term: 12 000 min ⁻¹
Shaft load	axial 40 N / radial 60 N
Operating temperature	-40 ... 70 °C
Weight approx. ST/MT	260 g / 310 g
Technical Data - electrical	
Supply voltage	DC 10 - 30 V
Max. current w/o load	max. 250 mA
Interface	SSI programmable
Resolution singleturn	10 - 17 Bit
Resolution multiturn	12 Bit
Parameterization	resolution, code type, sense of rotation, output format, warning, alarm
Control input	Direction, Preset 1, Preset 2
Alarm output	Alarm bit
Status LED	Green = ok.; red = alarm
Connection	Cable radial or axial Conin radial or axial, ccw
Page	142

Absolute Shaft Encoders

Stainless Steel / Explosion-Proof



Type	AC 59/61	AX 70/ AX 71 (Stainless)
Special Features	<ul style="list-style-type: none"> ■ Compact design ■ Protection class IP67 ■ High corrosion resistance ■ Robust design ■ Resolution up to 29 Bit (17 Bit ST, 12 Bit MT) ■ Connection with cable or with bus terminal box ■ Applications: <ul style="list-style-type: none"> - Packaging machine for food and beverage - Ship equipment (e.g. cranes, winches, cable laying ships) - Offshore - Applications 	<ul style="list-style-type: none"> ■ ATEX certification for gas and dust explosion proof ■ EX-classification: Ex II 2 G/D E Ex d II C T4/T6 ■ Same electrical performance as ACURO industry ■ Protection class up to IP67 ■ Diameter only 70 mm ■ Robust design ■ Available with stainless steel ■ Resolution up to 29 Bit (17 Bit ST, 12 Bit MT) ■ Applications: enamelling production line, petro chemistry, bottling machines, mixers, silo works, mills ■ Interfaces: SSI, SSI programmable, Profibus, CANopen
Technical Data – mechanical		
Housing diameter		70 mm
Shaft diameter	10 mm	10 mm
Flange	Square flange 63.5 x 63.5 mm	Clamping flange
Max. speed	Short term: 10 000 min ⁻¹ Continuous: 6 000 min ⁻¹	6 000 min ⁻¹ (T6) 10 000 min ⁻¹ (T4)
Torque	< 1 Ncm	≤ 1 Ncm
Moment of inertia	approx. 20 gcm ²	approx. 20 gcm ²
Max. shaft load	axial 40 N/ radial 60 N	axial 40 N/ radial 100 N
Vibration proof (IEC 68-2-6)	100 m/ s ² (10 - 500 Hz)	100 m/ s ² (10 - 500 Hz)
Shock resistance (IEC 68-2-27)	1000 m/ s ² (6 ms)	1000 m/ s ² (6 ms)
Operating temperature	SSI, BiSS, Parallel: -40...+100°C SSI-P, Interbus: -40...+70°C Profibus, CANopen, CANlayer2, DeviceNet: -40...+ 85°C	-40 ... +60 °C (T4) -40 ... +40 °C (T6)
Storage temperature	40...+ 85°C	-25 ... +80 °C
Material Shaft/ Housing	Stainless steel	Aluminium (AX 70) Stainless steel (AX 71)
Weight approx.	AC 59 with 1.5 m cable: 700 g AC 61 with 1.5 m cable: 980 g AC 61 with bus cover (MT): 1 180 g	1 000 g (AX 70), 1 900 g (AX 71)
Technical Data – electrical		
	The electrical data depend on the type of interface. Please refer to the specific interface chapter.	The electrical data depend on the type of interface. Please refer to chapter "AX 70 / AX 71".
Page	154	161

PRELIMINARY



APPLICATIONS

TECHNICAL DATA mechanical

Absolute Shaft Encoders

Type AC 36

ACURO industry

BiSS / SSI

- Overall length 36 mm
- For equipment engineering and industry
- Up to 17 Bit singleturn and 12 Bit multiturn
- Hollow shaft 6 mm
- +100°C operating temperature
- 10 000 rpm continuous operation
- Optical encoder with a true geared multiturn
- SSI or BiSS interface
- Option Sine 1 Vpp
- 500kHz bandwidth

The AC 36 is an absolute optical encoder with a true geared multiturn, optical sensing technology and 36 mm diameter. Equipped with a solid-shaft the AC 36 is mechanical compatible with all common inkremental encoders. The compact design allows to replace the adequate incremental encoders directly. As a result the technical facilities of absolute encoders can be used for the first time in equipment engineering and also in medical engineering. The mechanical design consists of two ball bearings supported mechanical shaft assembly. The AC 36 complements the **ACURO-industry** series with small frame sizes and the same performance as 58 mm versions.

BiSS-Interface

Unique within his class the AC 36 provides fully digital position data up to 17 Bit (singleturn) and 12 Bit (multi-turn) over the bidirectional synchronous interface with a variable clock rate up to 10 MHz. This corresponds a singleturn resolution of more than 130 000 mesured steps. Backward compatibility is realized through the SSI interface together with 2048 sine-cosine periods per revolution.

Integrated diagnostic system

The AC 36 is based on latest OptoAsic technology with an advanced diagnostic concept. A continous plausibility check controls the internal signal processing for each increment. A code check guarantees that the encoder signal represents bit by bit the mesured rotation. Also the operating temperature of the encoder can be measured, read out and monitored over warn and alarm bits with 8 bit resolution (1°C). Monitoring and controlling of the operating temperature ensures a maximum lifetime of the LED. Eventual failures are indicated early over warn bits.

Housing diameter	37.5 mm
Protection class shaft input	IP64
Protection class housing	IP64
Flange	pilot flange
Shaft diameter	6 mm
Max. speed	Continuous 10 000 min ⁻¹ , short term 12 000 min ⁻¹
Starting torque	0.01 Nm
Moment of inertia	2.5 x 10 ⁻⁶ kgm ²
Shock resistance DIN EN 60068-2-27	1 000 m/s ² (6 ms)
Vibration resistance DIN EN 60068-2-6	100 m/s ² (10 ... 2 000 Hz)
Operating temperature	-25...+100 °C
Storage temperature	-15...+85 °C (because of packing)
Weight approx. ST/MT	80 g / 130 g

TECHNICAL DATA electrical

Supply voltage	DC 5 V, -5 % /+10% or DC 7 - 30 V
Max. current w/o load ST/MT	50 mA / 100mA
Interface	Standard SSI or BiSS
Lines / drives	Clock and Data / RS422
Output code	Gray or binary
Resolution singleturn	13 Bit - 17 Bit
Resolution multiturn	12 Bit
Incremental signals optional	Sine - Cosine 1 Vpp
Number of pulses	2048
3dB limiting frequency	500 kHz
Alarm output	Alarm bit (SSI Option) Warning bit and alarm bit (BiSS)
Connection	Cable axial or radial

DIMENSIONAL DRAWINGS

Connection axial

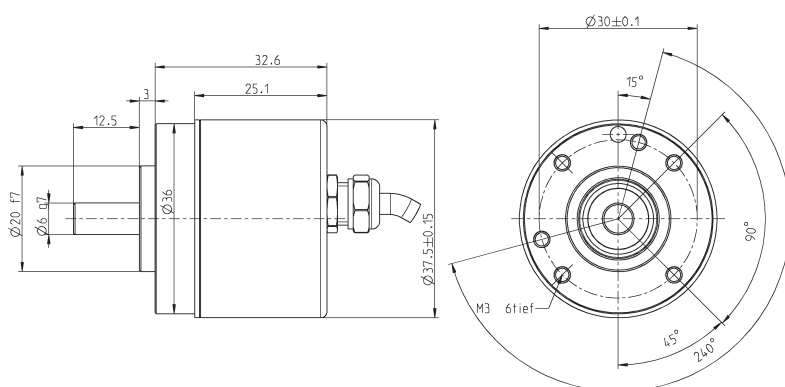

Dimensions in mm

Connection radial

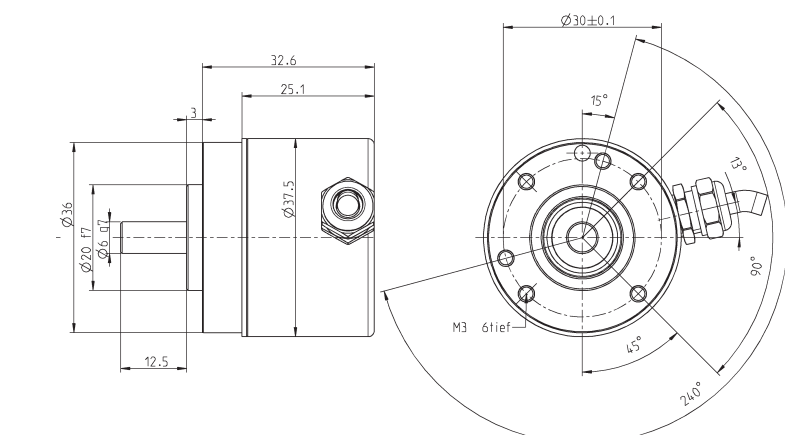

Dimensions in mm

PIN ASSIGNMENT

Signal	Colour cable old with BI, SG, SB	Colour cable old with SC	Colour cable new
DC 5 / 7-30 V (U _B)	yellow/black	yellow/black	white
0 V (U _N)	white/green	white/green	brown
Clock	white	white	yellow
$\overline{\text{Clock}}$	brown	brown	green
Data	black	black	pink
$\overline{\text{Data}}$	violet	violet	grey
A	nc.	green	white/green ¹
$\overline{\text{A}}$	nc.	yellow	brown/green ¹
B	nc.	blue	red/blue ¹
$\overline{\text{B}}$	nc.	red	grey/pink ¹
DC 5 V Sensor	nc.	red/black	violet ¹
0 V Sensor	nc.	brown/green	black ¹

¹ only with "SC"

ORDERING INFORMATION

Type	Resolution	Supply voltage	Flange, Protection, Shaft	Interface	Connection
<input type="text"/>	/ <input type="text"/>	<input type="text"/>	<input type="text"/>	<input type="text"/>	<input type="text"/>
AC 36	0012 12 Bit ST 0013 13 Bit ST 0014 14 Bit ST 0017 17 Bit ST 1213 12 Bit MT+13 Bit ST 1217 12 Bit MT+17 Bit ST (BiSS)	A DC 5 V E DC 7 - 30 V	R.41 Clamping ring, IP64, solid shaft 6 mm	SC SSI Gray + SinCos 1 Vpp BI BiSS SG SSI gray SB SSI binary	A Cable axial 1.5 m B Cable radial 1.5 m

Absolute Shaft Encoders ACURO industry

Overview Functions and Versions AC 58

	SSI	BiSS	Parallel ST	Parallel MT	SSI para.	Profibus	DeviceNet	Interbus	CAN	CANopen	SUC0net
Electrical											
Supply DC 5 V	•	•	(Option)	(Option)							
Supply DC 10-30 V	•	•	•	•	•	•	•	•	•	•	•
Preset key with LED (not IP67)	•	•	only LED	•	•						
Diagnostics											
- LED indication	•	•		•	•	•	•	•	•	•	
- Warning		•				•					
- Alarm bit	(Option)	•				•	•	•	•	•	
- Alarm output	(Option)	(Option)	•	•							
- Temperature measurement	(Option)	•									
Connection for "tico"											
Parameterization (PC, with Acuro Soft)	•	•							•	•	
Parameterization (Bus)						•	•	•		•	•
Inputs											
- Latch			•	•							
- Direction	•	•	•	•	•						
- 2 lines for present input					•						
- Tristate			•	•							
Special Functions											
- Speed						•			•	•	
- Acceleration						•			•	•	
- On time						•				•	
- Round axis										•	
- Limit values					•					•	
Optional 1 Vpp	•	•									
Connections											
Bus cover, 3 cable screw						•		•	•	•	
Bus cover, 2 cable screw+M12 for "tico"						•	•		•	•	
Bus cover, 2 cable screw							•				
Bus cover, 2 Conin 9-pole								•	•	•	
Bus cover, 2 Conin 12-pole						•					
Bus cover, 3 M12 4-pole						•					
Bus cover, 1 M12 5-pole							•				
Cable axial / radial	•	•	•	•	•			•	•	•	•
Cable ax /rad 0.1 m+37-pole Sub-D				•							
Conin 12-pole ax/rad CW/CCW	•	•			•	•			•	•	
Conin 17-pole ax/rad CW/CCW			•								
M12 8-pole ax/rad	•	•									
Mechanical											
Synchro fl., shaft 6x10 mm, IP64 or IP67	•	•	•	•	•	•	•	•	•	•	•
Clamping fl., shaft 10x19.5 mm, IP64 or IP67	•	•	•	•	•	•	•	•	•	•	•
Clamping fl., shaft 9.52x19.5 mm, IP64 or IP67	•	•	•	•	•	•	•	•	•	•	•
Hubshaft with tether 10 mm, IP64	•	•	•	•	•	•	•	•	•	•	•
Hubshaft with tether 12 mm, IP64	•	•	•	•	•	•	•	•	•	•	•
Hubshaft with tether 12,7 mm, IP64	•	•	•	•	•	•	•	•	•	•	•
Square flange, 63.5 mm, shaft 9.52x19.5 mm, IP64 or IP67	•	•	•	•	•	•	•	•	•	•	•
Square flange, 63.5 mm, shaft 10 x 19.5 mm, IP64 or IP67	•	•	•	•	•	•	•	•	•	•	•



Synchro flange



Hub shaft

- Compact design: 50mm length for single or multiturn
- Aids for start up and operation: diagnostic LED, preset key with optical response, status information
- Use of sine/ cosine signals for fast control task possible
- Control input: Direction
- Resolution up to 29 Bit

TECHNICAL DATA mechanical

Housing diameter	58 mm
Protection class shaft input	IP64 or IP67
Protection class housing	IP64 (IP67 optional)
Flange	Synchro flange, clamping flange, hubshaft with tether, square flange
Shaft diameter	Solid shaft 6 mm, 10 mm; Hub shaft 10 mm, 12 mm
Max. speed	Continuous 10 000 min ⁻¹ , short term 12 000 min ⁻¹
Starting torque	≤ 0.01 Nm
Moment of inertia	3.8 x 10 ⁻⁶ kgm ²
Spring tether (hollow shaft)	
Tolerance axial	±1.5 mm
Tolerance radial	±0.2 mm
Max. shaft load	axial 40 N / radial 60 N
Shock resistance DIN EN 60068-2-27	1 000 m/s ² (6ms)
Vibration resistance DIN EN 60068-2-6	100 m/s ² (10 ... 2.000 Hz)
Operating temperature	-40 ... 100 °C
Storage temperature	-25 ... 85 °C (because of packing)
Weight approx. ST/MT	260 g / 310 g

TECHNICAL DATA electrical

Supply voltage	DC 5 V, -5 % / +10 % or DC 10–30 V
Max. current w/o load ST/MT	50 mA / 100 mA
Interface	Standard SSI or BiSS
Lines / drives	Clock and Data / RS422
Output code	Binary or Gray parameterization with ACURO soft
Linearity	± ½ LSB (± 1 LSB for resolution > 13 Bit)
Resolution singleturn	10–17 Bit , Gray Excess: 360, 720 increments
Resolution multiturn	12 Bit
Incremental signals optional	Sine - Cosine 1 Vpp
Number of pulses	2 048
3dB limiting frequency	500 kHz
Absolute accuracy	±35''
Repeatability	±7''
Parameterization with Acuro soft	Code type, direction, warning, alarm
Control input	Direction
Reset key	Disable via parameterization
Alarm output	Alarm bit (SSI Option), warning bit and alarm bit (BiSS)
Status LED	Green = ok.; red = alarm
Connection	Cable or conin, axial or radial

DIMENSIONAL DRAWINGS

see chapter "Dimensional drawings ACURO industry", starting page 146

RECOMMENDED DATA TRANSFER RATE WITH SSI

The max. data transfer rate depends on the cable length.
For Clock/ Clock and Data/ Data please use twisted pairs. Use shielded cable.

Cable length	Frequency
< 50 m	< 400 kHz
< 100 m	< 300 kHz
< 200 m	< 200 kHz
< 400 m	< 100 kHz

DATA FORMAT singlturn

Resolution	Data bits											
	T1 ... T9	T10	T11	T12	T13	T14	T15	T16	T17	T18	T19	
9 Bit ¹	S8 ... S0	0	0	0	0	0	W ²					
10 Bit ¹	S9 ... S1	S0	0	0	0	0	W ²					
11 Bit ¹	S10 ... S2	S1	S0	0	0	0	W ²					
12 Bit ¹	S11 ... S3	S2	S1	S0	0	0	W ²					
13 Bit ¹	S12 ... S4	S3	S2	S1	S0	0	W ²					
14 Bit ¹	S13 ... S5	S4	S3	SS2	S1	S0	0	W ²				
15 Bit ¹	S14 ... S6	S5	S4	S3	S2	S1	S0	0	W ²			
16 Bit ¹	S15 ... S7	S6	S5	S4	S3	S2	S1	S0	0	W ²		
17 Bit ¹	S16 ... S8	S7	S6	S5	S4	S3	S2	S1	S0	0	W ²	

Examples for data format 9 Bit and 13 Bit with the optional bits alarm und parity

Resolution	Data bits											
	T1 ... T9	T10	T11	T12	T13	T14	T15	T16	T17	T18	T19	
9 Bit + P ³	S8 ... S0	0	0	0	P	0	W ²					
9 Bit + A ⁴	S8 ... S0	0	0	0	A	0	W ²					
9 Bit + P ³ + A ⁴	S8 ... S0	0	0	0	A	P	0	W ²				
13 Bit + P ³	S12 ... S4	S3	S2	S1	S0	P	0	W ²				
13 Bit + A ⁴	S12 ... S4	S3	S2	S1	S0	A	0	W ²				
13 Bit + P ³ + A ⁴	S12 ... S4	S3	S2	S1	S0	A	P	0	W ²			

DATA FORMAT Multiturn

Resolution	Data bits											
	T1 ... T12	T13 ... T21	T22	T23	T24	T25						
24 Bit ¹	M11 ... M0	S11 ... S2	S1	S0	0	W ²						
25 Bit ¹	M11 ... M0	S12 ... S3	S2	S1	S0	0	W ²					
26 Bit ¹	M11 ... M0	S13 ... S4	S3	S2	S1	S0	0	W ²				

Example for data format 24 Bit with the optional bits alarm und parity

24 Bit + P ³	M11 ... M0	S11 ... S2	S1	S0	P	0	W ²					
24 Bit + A ⁴	M11 ... M0	S11 ... S2	S1	S0	A	0	W ²					
24 Bit + P ³ + A ⁴	M11 ... M0	S11 ... S2	S1	S0	P	A	0	W ²				

S0 ... S16 Data bits for resolution per revolution

M0 ... M11 Data bits for number of revolutions (only for multiturn)

¹ Options (Parity bit, alarm and parity bit, zero bit) on request

² W: from this data bit on the data iteration for multiplex starts

³ Parity bit :Even Parity (The parity bit expands the data bits to an even number of 1-bits).
(Option)

⁴ Alarm bit: is set to "1" when over temperature, under temperature, disc breakage and defect LED

SYNCHRONOUS-SERIAL TRANSFER (SSI)

Synchronous readout of the encoder data is according to the clock rate given by the SSI-counterpart.

The number of clock rates is determined by the type of encoder (singleturn resp. multiturn) and the configuration of the special Bits as defined.

For multiple transactions (the stored value is readout several times successively) a fixed clock rate per transaction must be kept (for singleturn 13 resp. 14 clocks, for multiturn 25 resp. 26 clocks).

- In the rest position, when the last clock brush has passed by more than 30µs, the data output is logically at "1".
- With the first descending clock edge the encoder data and the special bits are loaded in the shift register of the encoder interface.

- With each ascending clock edge the data bits are serially readout, beginning with the MSB.

- At the end of the data transfer the data output is set to logically "0" for approx. 20µs.

If within these 20µs a further clock brush reaches the encoder interface, the already transferred data is readout once again.

This multiple transfer of the same data makes it possible to recognize transfer errors.

- After the 20µs the data output goes to its rest position, logically "1". Subsequently new encoder data can be readout.

PIN ASSIGNMENT Cable & Conin

Cable	Conin	Signal
brown ³	1	0V (supply voltage)
pink	2	Data
yellow	3	Clock
	4	N.C.
blue	5	Direction ¹
red	6	N.C.
violet	7	N.C.
white ³	8	DC 5/10 - 30 V
	9	N.C.
grey	10	Data
green	11	Clock
black	12	0V-signal output ²

¹ Direction: + U_B or unconnected = ascending code values with rotation cw
0 V = descending code values with rotation cw

² Connected with 0 V in the encoder. Use this output to lay Direction on logical "0" if required.

³ use only the thin wires (∅ = 0.14 mm)

PIN ASSIGNMENT M12



M12 Plug-in connector 8 pole		
Colour	Pin	Signal
white	1	DC 10 - 30 V
brown	2	0 V
	3	N.C.
green	4	Clock
pink	5	Data
yellow	6	Clock
blue	7	Direction ¹
grey	8	Data

¹ Direction: + U_B or unconnected = ascending code values with rotation cw
0 V = descending code values with rotation cw

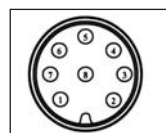

View on connector

ACCESSORIES

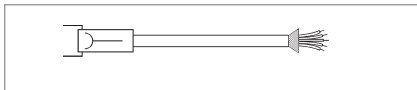
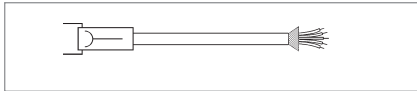

	Ordering code
M12 plug	3 539 597

Extension cable with M12 plug	Ordering code
3 m	1 565 329
5 m	1 565 330
10 m	1 565 331

Mating connector: 12 pin Conin	
	Ordering code
clockwise (C,D)	3 539 202
counter clockwise (G,H)	3 539 229
cable not made up with connector	see chapter "Accessories" (page 236) (ordering code 3 280 220)

Extension cable with plug	Ordering code
clockwise 3 m	1 542 003
(C,D) 5 m	1 542 004
10 m	1 542 005
counter clockwise 3 m	1 542 010
(G,H) 5 m	1 542 011
10 m	1 542 012

	Ordering code
ACURO soft, PC connecting cable, incl. power pack 230 VA, for CONIN 12 pole, CCW (suited for supply voltage E and connection G or H)	on request

	Ordering code
Position indicationsigno-SSI	see chapter "Accessories" (page 236)
Mounting eccentric for synchronous flange	0 070 655
Diaphragm coupling (hub 6/6 mm)	3 520 081
Diaphragm coupling (hub 10/10 mm)	3 520 088

ORDERING INFORMATION ACURO industry BiSS

Type	Resolution	Supply voltage	Flange, Protection, Shaft	Interface	Connection
<input type="checkbox"/>	<input type="checkbox"/>	<input type="checkbox"/>	<input type="checkbox"/>	<input type="checkbox"/>	<input type="checkbox"/>
AC58	0010 10 Bit ST 0012 12 Bit ST 0013 13 Bit ST 0014 14 Bit ST 0017 17 Bit ST 0360 360 increments ST ¹ 0720 720 increments ST ² 1212 12 Bit MT+12 Bit ST 1213 12 Bit MT+13 Bit ST 1214 12 Bit MT+14 Bit ST 1217 12 Bit MT+17 Bit ST higher resolutions on request	A DC 5 V * E DC 10 - 30 V	S.41 Synchro, IP64, 6x10mm S.71 Synchro, IP67 ³ , 6x10mm K.42 Clamping, IP64, 10x19.5mm K.72 Clamping, IP67 ³ , 10x19.5mm K.46 Clamping, IP64, 9.52x19.5mm K.76 Clamping, IP67 ³ , 9.52x19.5mm F.42 Hubshaft with tether, IP64, 10x19.5mm hollow shaft F.47 Hubshaft with tether, IP64, 12x19.5mm hollow shaft F.46 Hubshaft with tether, IP64, 9.52x19.5mm hollow shaft Q.42 Square, IP64, 10x19.5mm Q.72 Square, IP67 ³ , 10x19.5mm Q.46 Square, IP64, 9.52x19.5mm Q.76 Square, IP67 ³ , 9.52x19.5mm	BI BiSS (Digital) BC BiSS (+SinCos 1Vpp) ⁴	A Cable axial B Cable radial C Conin 12 pole axial cw D Conin 12 pole radial cw G Conin 12 pole axial ccw H Conin 12 pole radial ccw 7 M 12, 8 pole axial 8 M 12, 8 pole radial
¹ with Offset 76 (value range 76...435) ² with Offset 152 (value range 152...871) ³ Protection class IP67 not available in combination with preset key and LED display ⁴ not with connection "7" and "8" * max. cable length: 40 m Preferably available versions are printed in bold type.					

ORDERING INFORMATION ACURO industry SSI

Type	Resolution	Supply voltage	Flange, Protection, Shaft	Interface	Connection
<input type="checkbox"/>	<input type="checkbox"/>	<input type="checkbox"/>	<input type="checkbox"/>	<input type="checkbox"/>	<input type="checkbox"/>
AC58	0010 10 Bit ST 0012 12 Bit ST 0013 13 Bit ST 0014 14 Bit ST 0017 17 Bit ST 0360 360 increments ST ¹ 0720 720 increments ST ² 1212 12 Bit MT+12 Bit ST 1213 12 Bit MT+13 Bit ST higher resolutions on request	A DC 5 V * E DC 10 - 30 V	S.41 Synchro, IP64, 6x10mm S.71 Synchro, IP67 ³ , 6x10mm K.42 Clamping, IP64, 10x19.5mm K.72 Clamping, IP67 ³ , 10x19.5mm K.46 Clamping, IP64, 9.52x19.5mm K.76 Clamping, IP67 ³ , 9.52x19.5mm F.42 Hubshaft with tether, IP64, 10x19.5mm hollow shaft F.47 Hubshaft with tether, IP64, 12x19.5mm hollow shaft F.46 Hubshaft with tether, IP64, 9.52x19.5mm hollow shaft Q.42 Square, IP64, 10x19.5mm Q.72 Square, IP67 ³ , 10x19.5mm Q.46 Square, IP64, 9.52x19.5mm Q.76 Square, IP67 ³ , 9.52x19.5mm	SB SSI Binary SG SSI Gray SC SSI Gray (+SinCos 1Vpp) ⁴	A Cable axial B Cable radial C Conin 12 pole axial cw D Conin 12 pole radial cw G Conin 12 pole axial ccw H Conin 12 pole radial ccw 7 M 12, 8 pole, axial 8 M 12, 8 pole, radial
¹ with Offset 76 (value range 76...435) ² with Offset 152 (value range 152...871) ³ Protection class IP67 not available in combination with preset key and LED display ⁴ not with connection "7" and "8" * max. cable length: 40 m Preferably available versions are printed in bold type.					



Synchro flange



Hub shaft

- Compact design
- Aids for start up and operation: diagnostic LED, preset key * with optical response, status information
- Output Tristate short circuit-proof
- Gray or Binary code
- Encoder monitoring

TECHNICAL DATA mechanical

Housing diameter	58 mm
Protection class shaft input	IP64 or IP67
Protection class housing	IP67 with ST, IP64 with MT (IP67 optional)
Flange	Synchro flange, clamping flange, hubshaft with tether, square flange
Shaft diameter	Solid shaft 6 mm, 10 mm; hub shaft 10 mm, 12 mm
Max. speed	Continuous 10 000 min ⁻¹ , short term 12 000 min ⁻¹
Starting torque	≤ 0.01 Nm
Moment of inertia	3.8 x 10 ⁻⁶ kgm ²
Spring tether (hollow shaft)	
Tolerance axial	±1.5 mm
Tolerance radial	±0.2 mm
Max. shaft load	axial 40 N / radial 60 N
Shock resistance DIN EN 60068-2-27	1 000 m/s ² (6 ms)
Vibration resistance DIN EN 60068-2-6	100 m/s ² (10 ... 2 000 Hz)
Operating temperature	-40 ... 100 °C
Storage temperature	-40 ... 85 °C
Weight approx. ST/MT	350 g / 400 g

TECHNICAL DATA electrical

Supply voltage	DC 10–30 V (DC 5 V on request)
Max. current w/o load ST/MT	200 mA / 300 mA
Interface	Parallel
Output code	Binary, Gray, Gray Excess
Resolution singleturn	10 – 14 Bit, Gray Excess: 360, 720 increments
Resolution multiturn	12 Bit
Linearity	±1/2 LSB
Output current	30 mA per Bit, short-circuit-proof
Alarm output	NPN o.c. Max 5 mA
Control inputs	Latch, Direction, Tristate with ST, Tristate with MT
Connection	Cable, axial or radial Conin 17 pole, axial or radial Sub-D 37 pole

* Note: preset key only with MT (IP64), preset value = 0

DIMENSIONAL DRAWINGS

see chapter "Dimensional drawings ACURO industry", starting page 146

DATA OUTPUT LEVEL

Supply voltage U_B	DC 5 V - 5 % +10 % *	DC 10 - 30 V
Output level High	≥ 3.5 V (30 mA) ≥ 3.9 V (10 mA)	$\geq U_B - 2.2$ V (30 mA) $\geq U_B - 1.8$ V (10 mA)
Output level Low	≤ 1.6 V (30 mA) ≤ 1.2 V (10 mA)	≤ 1.6 V (30 mA) ≤ 1.2 V (10 mA)
Rise time (1.5 m Cable)	≤ 0.1 μ s	≤ 0.2 μ s
Drop time (1.5 m Cable)	≤ 0.05 μ s	≤ 0.1 μ s

* on request

Control inputs !:		
Input	Level logical (physical)	Function
Direction	1 (+ U_B or open) 0 (0 V)	ascending code values when turning clockwise (cw) descending code values when turning clockwise (cw)
Latch	1 (+ U_B or open) 0 (0 V)	encoder data continuously changing at output encoder data stored and constant at output
Tristate (with singleturn)	1 (+ U_B or open) 0 (0 V)	outputs active outputs at high impedance (Tristate mode)
Tristate (with multiturn)	1 (+ U_B) 0 (0 V or open)	outputs at high impedance (Tristate mode) outputs active

¹ Typical actuating delay time 10 μ s with push-pull selection; when selected via O.C., an external pull-down resistor (1 K Ω) is required

PIN ASSIGNMENT SINGLETURN, CABLE

Parallel interface with cable:					
Colour (PVC)	9 Bit / 360 incr.	10 Bit / 720 incr.	12 Bit	13 Bit	14 Bit
grey/pink	N.C.	N.C.	N.C.	N.C.	S0 (LSB)
brown/yellow	N.C.	N.C.	N.C.	S0 (LSB)	S1
brown/grey	N.C.	N.C.	S0 (LSB)	S1	S2
red/blue	N.C.	N.C.	S1	S2	S3
violet	N.C.	S0 (LSB)	S2	S3	S4
white/brown	S0 (LSB)	S1	S3	S4	S5
white/green	S1	S2	S4	S5	S6
white/yellow	S2	S3	S5	S6	S7
white/grey	S3	S4	S6	S7	S8
white/pink	S4	S5	S7	S8	S9
white/blue	S5	S6	S8	S9	S10
white/red	S6	S7	S9	S10	S11
white/black	S7	S8	S10	S11	S12
brown/green	S8 (MSB)	S9 (MSB)	S11 (MSB)	S12 (MSB)	S13 (MSB)
yellow	Tristate S0...S8	Tristate S0...S9	Tristate S0...S11	Tristate S0...S12	Tristate S0...S13
pink	Latch	Latch	Latch	Latch	Latch
green	Direction	Direction	Direction	Direction	Direction
black	0 V	0 V	0 V	0 V	0 V
red	DC 5 V/10...30 V	DC 5 V/10...30 V	DC 5 V/10...30 V	DC 5 V/10...30 V	DC 5 V/10...30 V
brown	Alarm	Alarm	Alarm	Alarm	Alarm

PIN ASSIGNMENT SINGLETURN, FLANGE CONNECTOR

Parallel interface with flange connector 17 pole (Conin):					
Pin	9 Bit / 360 incr.	10 Bit / 720 incr.	12 Bit	13 Bit	14 Bit
1	S0 (LSB)	S0 (LSB)	S0 (LSB)	S12 (MSB)	S13 (MSB)
2	S1	S1	S1	S11	S12
3	S2	S2	S2	S10	S11
4	S3	S3	S3	S9	S10
5	S4	S4	S4	S8	S9
6	S5	S5	S5	S7	S8
7	S6	S6	S6	S6	S7
8	S7	S7	S7	S5	S6
9	S8 (MSB)	S8	S8	S4	S5
10	N.C.	S9 (MSB)	S9	S3	S4
11	N.C.	N.C.	S10	S2	S3
12	Tristate S0...S8	Tristate S0...S9	S11 (MSB)	S1	S2
13	Latch	Latch	Latch	S0 (LSB)	S1
14	Direction	Direction	Direction	Direction	S0 (LSB)
15	0 V	0 V	0 V	0V	0 V
16	DC 5 V/10...30 V	DC 5 V/10...30 V	DC 5 V/10...30 V	DC 5 V/10...30 V	DC 5 V/10...30 V
17	Alarm	Alarm	Alarm	Latch / Alarm	Latch / Alarm

PIN ASSIGNMENT MULTITURN, CABLE

Parallel interface			Parallel interface		
Cable (TPE)	10 cm cable with 37 pole Sub-D-plug		Cable (TPE)	10 cm cable with 37 pole Sub-D-plug	
Farbe	Pin	Connection	Colour	Pin	Connection
brown	2	S0	white/blue	14	M4 ¹
green	21	S1	brown/blue	33	M5 ¹
yellow	3	S2	white/red	15	M6 ¹
grey	22	S3	brown/red	34	M7 ¹
pink	4	S4	white/black	16	M8 ²
violet	23	S5	brown/black	35	M9 ²
grey/pink	5	S6	grey/green	17	M10 ²
red/blue	24	S7	yellow/grey	36	M11 ²
white/green	6	S8	pink/green	18	Alarm
brown/green	25	S9	yellow/pink	10	Direction
white/yellow	7	S10	green/blue	30	Latch
yellow/brown	26	S11	yellow/blue	12	Tristate
white/grey	8	M0	red (0.5 mm ²)	13	DC 10...30 V
grey/brown	27	M1	white (0.5 mm ²)	31	DC 10...30 V
white/pink	9	M2	blue (0.5 mm ²)	1	0 V
pink/brown	28	M3	black (0.5 mm ²)	20	0 V

¹ N. C. with resolution 16 Bit (4 Bit MT)

² N. C. with resolution 16 Bit or 20 Bit (4 or 8 Bit MT)

ACCESSORIES

	Ordering code
Mounting eccentric for synchronous flange	0 070 655
Diaphragm coupling (hub 6/6 mm)	3 520 081
Diaphragm coupling (hub 10/10 mm)	3 520 088

ORDERING INFORMATION

Type	Resolution	Supply voltage	Flange, Protection, Shaft	Interface	Connection
<input type="checkbox"/>	<input type="checkbox"/>	<input type="checkbox"/>	<input type="checkbox"/>	<input type="checkbox"/>	<input type="checkbox"/>
AC58	0010 10 Bit ST 0012 12 Bit ST 0013 13 Bit ST 0014 14 Bit ST 0360 360 increments ST ¹ 0720 720 increments ST ² 0412 4 Bit MT+12 Bit ST 0812 8 Bit MT+12 Bit ST 1212 12 Bit MT+12 Bit ST	E DC 10 - 30 V	S.41 Synchro, IP64, 6x10mm S.71 Synchro, IP67 ³, 6x10mm K.42 Clamping, IP64, 10x19.5mm K.72 Clamping, IP67 ³, 10x19.5mm K.46 Clamping, IP64, 9.52x19.5mm K.76 Clamping, IP67 ³ , 9.52x19.5mm F.42 Hubshaft with tether, IP64, 10x19.5mm hollow shaft F.47 Hubshaft with tether, IP64, 12x19.5mm hollow shaft F.46 Hubshaft with tether, IP64, 9.52x19.5mm hollow shaft Q.42 Square, IP64, 10x19.5mm Q.72 Square, IP67 ³ , 10x19.5mm Q.46 Square, IP64, 9.52x19.5mm Q.76 Square, IP67 ³ , 9.52x19.5mm	PB Parallel Binary PG Parallel Gray	A Cable axial 1.5 m (ST/MT) B Cable radial 1.5 m (ST/MT) U Conin 17 pole axial ccw (ST) V Conin 17 pole radial ccw (ST) W Conin 17 pole axial cw (ST) Y Conin 17 pole radial cw (ST) A-A1-F 0.1m Cable axial + 37 pole Sub-D (MT) B-A1-F 0.1m cable radial + 37 pole Sub-D (MT)
¹ with Offset 76 (value range 76...435) ² with Offset 152 (value range 152...871) ³ Protection class IP67 not available in combination with preset key and LED display Preferably available versions are printed in bold type.					



- Diagnostic LED
- Cable or M12-plug connector
- Output of speed, acceleration
- Programmable: Resolution, Preset, Direction
- Option: Display „tico“
- Address via interface parameterizable (optional)

TECHNICAL DATA mechanical

Housing diameter	58 mm
Protection class shaft input	IP64 or IP67
Protection class housing	IP67
Flange	Synchro flange, clamping flange, hubshaft with tether, square flange
Shaft diameter	Solid shaft 6 mm, 10 mm; hub shaft 10 mm, 12mm
Max. speed	12 000 min ⁻¹ (short term), 10 000 min ⁻¹ (continuous)
Starting torque	≤ 0.5 Ncm
Moment of inertia	3.8 10 ⁻⁶ kgm ²
Spring tether (hollow shaft)	
Tolerance axial	± 1.5 mm
Tolerance radial	± 0.2 mm
Max. shaft load	axial 40 N / radial 60 N
Vibration resistance (IEC 68-2-6)	100 m/s ² (10 - 500 Hz)
Shock resistance (IEC 68-2-27)	1000 m/s ² (6 ms)
Operating temperature	-40...+85 °C
Storage temperature	-40...+85 °C
Material shaft	Stainless steel
Material housing	Aluminium
Weight approx.	350 g (ST), 400 g (MT)

TECHNICAL DATA electrical

Supply voltage	DC 10 - 30 V
Max. current w/o load ST/MT	220mA/ 250mA
EMC	EN 61326: Class A
Interface	RS 485
Protocol	Profibus DP with encoder profile class C2 (parameterizable)
General design	as per EN 61010-Part 1, protection class III, contamination level 2, overvoltage class II
Linearity	± ½ LSB (± 1 LSB for resolution 13, 14, 25, 26 Bit)
Output code	Binary
Resolution singleturn	10 to 14 Bit
Resolution multiturn	12 Bit
Baud rate	is automatically set within a range of 9.6 KBaud through 12 MBaud
Device address	adjustable with DIP switches, via fieldbus (optional)
Programmable	Resolution, Preset, Direction

TECHNICAL DATA electrical (continued)

Integrated special functions	Speed, acceleration, on time
Bus termination resistor	set via DIP switches
Connection	Bus cover with: <ul style="list-style-type: none"> · 3 sealed cable exits · double conin 12 pole, cw, radial · 3 M12 · 4 pole M12 f. "tico" display + 2 sealed cable exits

DIMENSIONAL DRAWINGS

see chapter "Dimensional drawings ACURO industry", starting page 146

PIN ASSIGNMENT Bus cover with double conin

Pin	Bus cover with double conin		Description
	IN (pins)	OUT (socket)	
1		GND1	Data Ground (M5V) ¹
2	A	A	Receive/Transmit Data-Negative (A)
3			
4	B	B	Receive/Transmit Data-Positive (B)
5			
6		VCC1	+5 V signal output (P5V) ¹
7	DC 10 - 30 V	DC 10 - 30 V	Supply voltage +U _B (P24)
8	0 V	0 V	Supply voltage Ground (M24)
9			
10			
11			
12			
screen	screen	screen	screen connected with encoder housing

¹ can be used as power supply for an external bus termination resistor

PIN ASSIGNMENT Bus cover with 3 M12

Pin	Connector 1	Connector 2	Socket
1		UB in	+5 V signal output (P5V) ¹
2	A in		A out
3		0 V in	Data Ground (M5V) ¹
4	B in		B out
5	screen	screen	screen

¹ can be used as power supply for an external bus termination resistor

PIN ASSIGNMENT Bus cover with 3 sealed cable exits

Pin	Signal
1	UB in (DC 10 - 30V)
2	0 V in
3	UB out
4	0 V out
5	B in
6	A in
7	B out
8	A out

Absolute Shaft Encoders ACURO industry

Type AC 58 Profibus

STARTUP

The encoder can be easily and quickly installed and programmed with the GSD file.

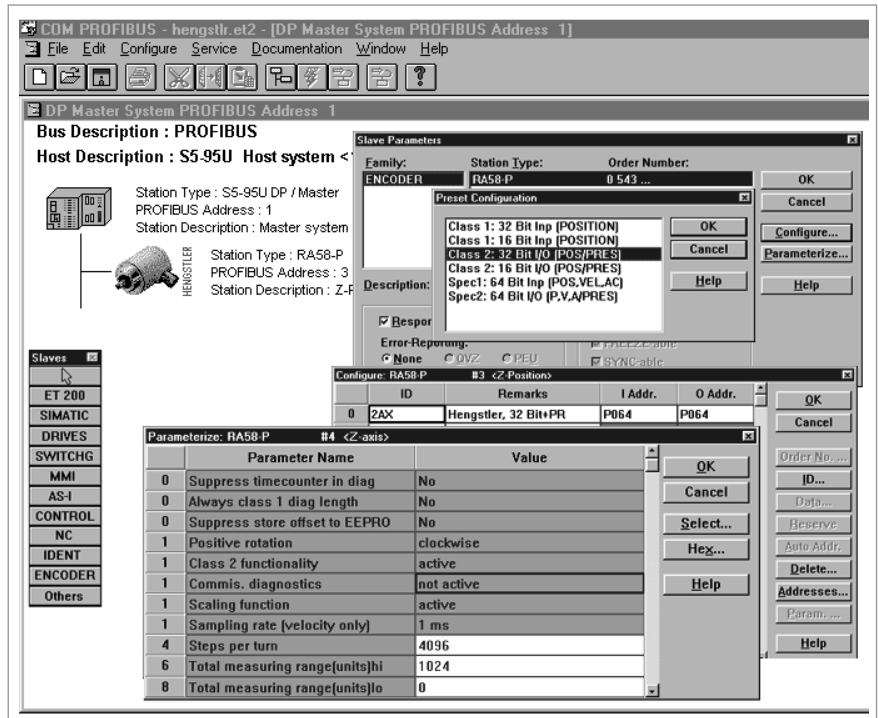

ACCESSORIES



	Ordering code
GSD-file	www.hengstler.com
Technical manual, German	2 565 090 (Web)
Technical manual, English	2 565 255 (Web)
Clamping eccentric for synchro flange	0 070 655
Diaphragm coupling (hub 6/6 mm)	3 520 081
Diaphragm coupling (hub 10/10 mm)	3 520 088
Mating connector for connection I (Bus input, 12 pole, bushing, cw)	3 539 202
Mating connector for connection I (Bus output, 12 pole, pins, cw)	3 539 186
"Tico" display for connection T	0 731 205
Connection cable bus cover (connection T) to "tico" display, 1.5m	3 539 575

ORDERING INFORMATION

Type	Resolution	Supply voltage	Flange, Protection, Shaft	Interface	Connection
<input type="checkbox"/>	<input type="checkbox"/>	<input type="checkbox"/>	<input type="checkbox"/>	<input type="checkbox"/>	<input type="checkbox"/>
AC58	0010 10 Bit ST 0012 12 Bit ST 0013 13 Bit ST 0014 14 Bit ST 1212 12 Bit MT+12 Bit ST 1213 12 Bit MT+13 Bit ST 1214 12 Bit MT+14 Bit ST	E DC 10 - 30 V	S.41 Synchro, IP64, 6x10mm S.71 Synchro, IP67, 6x10mm K.42 Clamping, IP64, 10x19.5mm K.72 Clamping, IP67, 10x19.5mm K.46 Clamping, IP64, 9.52x19.5mm K.76 Clamping, IP67, 9.52x19.5mm F.42 Hubshaft with tether, IP64, 10x19.5mm hollow shaft F.47 Hubshaft with tether, IP64, 12x19.5mm hollow shaft F.46 Hubshaft with tether, IP64, 9.52x19.5mm hollow shaft Q.42 Square, IP64, 10x19.5mm Q.72 Square, IP67, 10x19.5mm Q.46 Square, IP64, 9.52x19.5mm Q.76 Square, IP67, 9.52x19.5mm	DP Profibus	I Bus cover with double conin 12 pole cw radial R Bus cover with 3 M12 T Bus cover with 4 pole M12 f. "tico" display + 2 sealed cable exits Z Bus cover with 3 sealed cable exits
Preferably available versions are printed in bold type.					



- Diagnostic LED
- Programmable: Resolution, Preset, Offset, Direction
- Output of speed and acceleration
- Operation timer
- Alarm and warning display
- Direction
- Option: display „tico“
- Address and baud rate via interface parameterizable (optional)

TECHNICAL DATA mechanical

Housing diameter	58 mm
Protection class shaft input	IP64 or IP67
Protection class housing	Connection bus cover IP67 Connection cable, conin IP64 (IP67 optional)
Flange	Synchro flange, clamping flange, hubshaft with tether, square flange
Shaft diameter	Solid shaft 6 mm, 10 mm; hub shaft 10 mm, 12mm
Max. speed	12 000 min ⁻¹ (short term), 10 000 min ⁻¹ (continuous)
Starting torque	≤ 0.5 Ncm
Moment of inertia	3.8 10 ⁻⁶ kgm ²
Spring tether (hollow shaft)	
Tolerance axial	± 1.5 mm
Tolerance radial	± 0.2 mm
Max. shaft load	axial 40 N / radial 60 N
Vibration resistance (IEC 68-2-6)	100 m/s ² (10 - 500 Hz)
Shock resistance (IEC 68-2-27)	1000 m/s ² (6 ms)
Operating temperature	-40...+85 °C
Storage temperature	-40...+85 °C
Material shaft	Stainless steel
Material housing	Aluminium
Weight approx.	350 g (ST), 400 g (MT)

TECHNICAL DATA electrical

Supply voltage	DC 10 - 30 V
Max. current w/o load ST/MT	220 mA/ 250 mA
EMC	Noise emission according to EN 50081-2 Immunity to interference according to EN 50082-2
Interface	CAN High-Speed according to ISO/DIS 11898
Protocol	CANopen according to DS 301 with profile DSP 406, programmable encoder according class C2
General design	as per EN 61010-Part 1, protection class III, contamination level 2, overvoltage class II
Programmable	Resolution, Preset, Offset, Direction
Resolution singleturn	10 to 14 Bit
Resolution multiturn	12 Bit
Linearity	± ½ LSB (± 1 LSB for resolution 13, 14, 25, 26 Bit)
Output code	Binary
Integrated special functions	Speed, acceleration, round axis, limit values, operation timer

TECHNICAL DATA electrical (continued)

Updating of values	every millisecond (adjustable), on request
Basic identifier	set via DIP switches
Baud rate	set via DIP switches within a range of 10 through 1000 Kbit/s
Bus termination resistor	set via DIP switches
Connection	Cable radial or axial Conin radial or axial, cw or ccw Bus cover with: · 3 sealed cable exits · double conin 9 pole cw radial · 4 pole M12 f. "tico" display + 2 sealed cable exits

DIMENSIONAL DRAWINGS

see chapter "Dimensional drawings ACURO industry", starting page 146

PIN ASSIGNMENT Bus cover with double conin

Conin-PIN	Bus cover with	
	Pin insert (IN)	Socket insert (OUT)
1	CAN in +	CAN out +
2	CAN in -	CAN out-
3	CAN GND in	CAN GND out
4	N.C.	N.C.
5	N.C.	N.C.
6	N.C.	N.C.
7	UB in	UB out
8	0 V in	0 V out
9	N.C.	N.C.
screen	screen ¹	screen ¹

¹ screen connected with encoder housing

PIN ASSIGNMENT with conin or cable

Conin Pin	TPE cable	Cable pairs	Signal
7	yellow	Pair 1	CAN in+
2	green		CAN in -
4	pink	Pair 2	CAN out +
5	grey		CAN out -
3	blue		CAN GND in
11	brown		CAN GND out
12	white 0.5 mm	Pair 3	UB in
10	brown 0.5 mm		0 V in
screen		screen	screen

PIN ASSIGNMENT Bus cover with 3 sealed cable exits

Connecting block KL 1 (10 pole)	
No.	Signal name
1	UB in (DC 10-30V)
2	0 V in
3	CAN in - (dominant L)
4	CAN in + (dominant H)
5	CAN GND in
6	CAN GND out
7	CAN out + (dominant H)
8	CAN out - (dominant L)
9	0 V out
10	UB out (DC 10-30V)

Absolute Shaft Encoders

Type AC 58

ACURO industry

CANopen

ACCESSORIES

	Ordering code
EDS-file as download from our homepage	www.hengstler.com
Technical manual, German	2 565 250 (Web)
Technical manual, English	2 565 329 (Web)
Clamping eccentric for synchro flange	0 070 655
Diaphragm coupling (hub 6/6 mm)	3 520 081
Diaphragm coupling (hub 10/10 mm)	3 520 088
Mating connector for connection I (Bus input, 9 pole, bushing, cw)	3 539 294
Mating connector for connection I (Bus output, 9 pole, pins, cw)	3 539 293
Mating connector for connection C; D (12 pole, cw)	3 539 202
Mating connector for connection G; H (12 pole, ccw)	3 539 229
"Tico" display for connection T	
(Caution: Neutralizes ohmic isolation)	0 731 205
Connection cable bus cover (connection T) to "tico" 1.5m	3 539 575

ORDERING INFORMATION

Type	Resolution	Supply voltage	Flange, Protection, Shaft	Interface	Connection
<input type="checkbox"/>	<input type="checkbox"/>	<input type="checkbox"/>	<input type="checkbox"/>	<input type="checkbox"/>	<input type="checkbox"/>
AC58	0010 10 Bit ST 0012 12 Bit ST 0013 13 Bit ST 0014 14 Bit ST 1212 12 Bit MT+12 Bit ST 1213 12 Bit MT+13 Bit ST 1214 12 Bit MT+14 Bit ST	E DC 10 - 30 V	S.41 Synchro, IP64, 6x10mm S.71 Synchro, IP67 ¹ , 6x10mm K.42 Clamping, IP64, 10x19.5mm K.72 Clamping, IP67 ¹ , 10x19.5mm K.46 Clamping, IP64, 9.52x19.5mm K.76 Clamping, IP67 ¹ , 9.52x19.5mm F.42 Hubshaft with tether, IP64, 10x19.5mm hollow shaft F.47 Hubshaft with tether, IP64, 12x19.5mm hollow shaft F.46 Hubshaft with tether, IP64, 9.52x19.5mm hollow shaft Q.42 Square, IP64, 10x19.5mm Q.72 Square, IP67 ¹ , 10x19.5mm Q.46 Square, IP64, 9.52x19.5mm Q.76 Square, IP67 ¹ , 9.52x19.5mm	OL CANopen OC CANopen (on request)	A Cable axial B Cable radial C Conin 12 pole axial cw D Conin 12 pole radial cw G Conin 12 pole axial ccw H Conin 12 pole radial ccw I Bus cover with double conin 9 pole radial cw Z Bus cover with 3 sealed cable exits

¹ Protection class IP67 in combination with connection A - H: Version without DIP switches and LED. Setting over fieldbus
Preferably available versions are printed in bold type.



- Diagnostic LED
- Poll and auto mode
- Programmable: Direction, limit values
- Option: Display „tico“

TECHNICAL DATA mechanical

Housing diameter	58 mm
Protection class shaft input	IP64 or IP67
Protection class housing	Connection bus cover IP67 Connection conin, cable IP64 (IP67 optional)
Flange	Synchro flange, clamping flange, hubshaft with tether, square flange
Shaft diameter	Solid shaft 6 mm, 10 mm; hub shaft 10 mm, 12mm
Max. speed	12 000 min ⁻¹ (short term), 10 000 min ⁻¹ (continuous)
Starting torque	≤ 0.5 Ncm
Moment of inertia	3.8 10 ⁻⁶ kgm ²
Spring tether (hollow shaft)	
Tolerance axial	± 1.5 mm
Tolerance radial	± 0.2 mm
Max. shaft load	axial 40 N / radial 60 N
Vibration resistance (IEC 68-2-6)	100 m/s ² (10 - 500 Hz)
Shock resistance (IEC 68-2-27)	1000 m/s ² (6 ms)
Operating temperature	-40...+85 °C
Storage temperature	-40...+85 °C
Material shaft	Stainless steel
Material housing	Aluminium
Weight approx.	350 g (ST), 400 g (MT)

TECHNICAL DATA electrical

Supply voltage	DC 10 - 30 V (SELV)
Max. current w/o load ST/MT	220 mA/ 250 mA
EMC	Noise emission according to EN 50081-2 Immunity to interference according to EN 50082-2
Interface	CAN High-Speed according to ISO/DIS 11898
Protocol	CAN 2.0 A
General design	as per EN 61010-Part 1, protection class III, contamination level 2, overvoltage class II
Resolution singleturn	10 to 14 Bit
Resolution multiturn	12 Bit
Programmable	Direction, limit values
Linearity	± ½ LSB (± 1 LSB for resolution 13, 14, 25, 26 Bit)
Output code	Binary
Updating of values	every millisecond
Basic identifier	set via DIP switches
Baud rate	set via DIP switches within a range of 10 through 1000 Kbit/s
Bus termination resistor	set via DIP switches

TECHNICAL DATA electrical (continued)

Connection	Cable radial or axial Conin radial or axial, cw or ccw Bus cover with: - 3 sealed cable exits - double conin 9 pole radial cw - 4 pole M12 f. "tico" display + 2 sealed cable exits
------------	--

DIMENSIONAL DRAWINGS

see chapter "Dimensional drawings ACURO industry", starting page 146

PIN ASSIGNMENT Bus cover with double conin

Conin PIN	Bus cover with	
	Pin insert (IN)	Socket insert (OUT)
1	CAN in +	CAN out +
2	CAN in -	CAN out-
3	CAN GND in	CAN GND out
4	N.C.	N.C.
5	N.C.	N.C.
6	N.C.	N.C.
7	UB in	UB out
8	0 V in	0 V out
9	N.C.	N.C.
screen	screen ¹	screen ¹

¹ screen connected with encoder housing

PIN ASSIGNMENT with conin or cable

Conin Pin	TPE cable	Cable pairs	Signal
7	yellow	Pair 1	CAN in+
2	green		CAN in -
4	pink	Pair 2	CAN out +
5	grey		CAN out -
3	blue	Pair 3	CAN GND in
11	brown		CAN GND out
12	white 0.5 mm		UB in
10	brown 0.5 mm		0 V in
screen	screen	screen	screen

PIN ASSIGNMENT Bus cover with 3 sealed cable exits

Connection block KL 1 (10 pole)	
No.	Signal name
1	UB in (DC 10-30V)
2	0 V in
3	CAN in - (dominant L)
4	CAN in + (dominant H)
5	CAN GND in
6	CAN GND out
7	CAN out + (dominant H)
8	CAN out - (dominant L)
9	0 V out
10	UB out (DC 10-30V)

ACCESSORIES

	Ordering code
Clamping eccentric for synchro flange	0 070 655
Diaphragm coupling (hub 6/6 mm)	3 520 081
Diaphragm coupling (hub 10/10 mm)	3 520 088
Mating connector for connection I (Bus input, 9 pole, bushing, cw)	3 539 294
Mating connector for connection I (Bus output, 9 pole, pins, cw)	3 539 293
Mating connector for connection C; D (12 pole, cw)	3 539 202
Mating connector for connection G; H (12 pole, ccw)	3 539 229
"Tico" display for connection T	
(Caution: Neutralizes ohmic isolation)	0 731 205
Connection cable bus cover (connection T) to "tico"	3 539 575

ORDERING INFORMATION

Type	Resolution	Supply voltage	Flange, Protection, Shaft	Interface	Connection
□	□	□	□	□	□
AC58	0010 10 Bit ST 0012 12 Bit ST 0013 13 Bit ST 0014 14 Bit ST 1212 12 Bit MT+12 Bit ST 1213 12 Bit MT+13 Bit ST 1214 12 Bit MT+14 Bit ST	E DC 10 - 30 V	S.41 Synchro, IP64, 6x10mm S.71 Synchro, IP67 ¹ , 6x10mm K.42 Clamping, IP64, 10x19.5mm K.72 Clamping, IP67 ¹ , 10x19.5mm K.46 Clamping, IP64, 9.52x19.5mm K.76 Clamping, IP67 ¹ , 9.52x19.5mm F.42 Hubshaft with tether, IP64, 10x19.5mm hollow shaft F.47 Hubshaft with tether, IP64, 12x19.5mm hollow shaft F.46 Hubshaft with tether, IP64, 9.52x19.5mm hollow shaft Q.42 Square, IP64, 10x19.5mm Q.72 Square, IP67 ¹ , 10x19.5mm Q.46 Square, IP64, 9.52x19.5mm Q.76 Square, IP67 ¹ , 9.52x19.5mm	CL CAN L2	A Cable axial ¹ B Cable radial ¹ C Conin 12 pole axial cw ¹ D Conin 12 pole radial cw ¹ G Conin 12 pole axial ccw ¹ H Conin 12 pole radial ccw ¹ I Bus cover with double conin 9 pole radial cw Z Bus cover with 3 sealed cable exits

¹ Protection class IP67 not available in combination with cable and conin connection (A - H)
Preferably available versions are printed in bold type.



TECHNICAL DATA mechanical

- Programmable: Resolution, Preset, Direction
- Allen Bradley compatible
- Scaleable
- Preset-Funktion
- Diagnostic LED
- Option: display „tico“

Housing diameter	58 mm
Protection class shaft input	IP64 or IP67
Protection class housing	IP67
Flange	Synchro flange, clamping flange, hubshaft with tether, square flange
Shaft diameter	Solid shaft 6 mm, 10 mm; hub shaft 10 mm, 12mm
Max. speed	12 000 min ⁻¹ (short term), 10 000 min ⁻¹ (continuous)
Starting torque	≤ 0.5 Ncm
Moment of inertia	3.8 · 10 ⁻⁶ kgm ²
Spring tether (hollow shaft)	
Tolerance axial	± 1.5 mm
Tolerance radial	± 0.2 mm
Max. shaft load	axial 40 N / radial 60 N
Vibration resistance (IEC 68-2-6)	100 m/s ² (10 - 500 Hz)
Shock resistance (IEC 68-2-27)	1000 m/s ² (6 ms)
Operating temperature	-40...+85 °C
Storage temperature	-40...+85 °C
Material shaft	Stainless steel
Material housing	Aluminium
Weight approx.	350 g (ST), 400 g (MT)

TECHNICAL DATA electrical

Supply voltage	DC 10 - 30 V
Max. current w/o load ST/MT	220 mA/ 250 mA
EMC	Interference emission according to EN 50081-2 Interference resistance according to EN 50082-2
Interface	CAN High-Speed according to ISO/DIS 11898 CAN-Specification 2.0 A (11 Bit Identifier)
General design	as per EN 61010-Part 1, protection class III, contamination level 2, overvoltage class II
Protocol	DeviceNet according to Rev. 2.0, programmable encoder
Resolution singleturn	10 to 14 Bit
Resolution multiturn	12 Bit
Programmable	Resolution, Preset, Direction
Linearity	± ½ LSB (± 1 LSB for resolution 13, 14, 25, 26 Bit)
Output code	Binary
Updating of values	every 5 Milliseconds
MAC-ID	set via DIP switches
Baud rate	set via DIP switches to 125, 250, 500 Kbaud
Bus termination resistor	set via DIP switches
Connection	Bus cover with <ul style="list-style-type: none"> · 2 sealed cable exits · 4 pole M12 f. "tico" display + 2 cable screw connections · M12, 5 pole

DIMENSIONAL DRAWINGS

see chapter "Dimensional drawings ACURO industry", starting page 146

RECOMMENDED DATA TRANSFER Lead type A

Shaft resistance	135...165 Ω (3...20MHz)
Operating capacity	< 30pF/m
Loop impedance	< 110 Ω/km
Strand diameter	> 0.64 mm
Strand cross section	> 0.34 mm ²

TRANSFER SPEEDS

Segment length	kBit/s
500 m	125
250 m	250
100 m	500

STARTUP

The encoder can be easily and quickly installed and programmed with the EDS file.

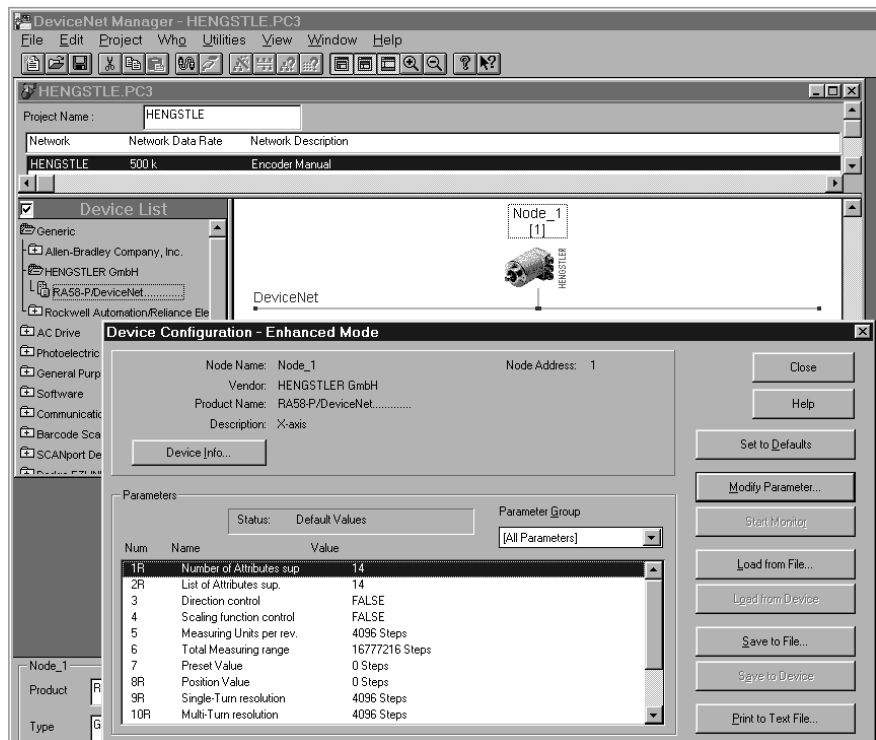

PIN ASSIGNMENT

Bus cover with 2 sealed cable exits

Terminals	
No.	Signal name
1	UB in (DC 10 - 30V)
2	0 V in
3	CAN-L
4	CAN-H
5	DRAIN
6	DRAIN
7	CAN-H
8	CAN-L
9	0 V out
10	UB out (DC 10 - 30V)

PIN ASSIGNMENT

Bus cover with M12, 5 pole

Pin	Connector	Colour
1	UB in (DC 10 - 30V)	white
2	0 V in	blue
3	CAN-L	green/yellow
4	CAN-H	black
5	DRAIN	brown

ACCESSORIES

	Ordering code
EDS-file as download from our homepage	www.hengstler.com
Technical manual, German	2 565 094 (Web)
Technical manual, English	2 565 256 (Web)
Clamping eccentric for synchro flange	0 070 655
Diaphragm coupling (hub 6/6 mm)	3 520 081
Diaphragm coupling (hub 10/10 mm)	3 520 088
"Tico" display for connection T	0 731 205
Connection cable bus cover (connection T) to "tico"	3 539 575

ORDERING INFORMATION

Type	Resolution	Supply voltage	Flange, Protection, Shaft	Interface	Connection
<input type="text"/>	<input type="text"/>	<input type="text"/>	<input type="text"/>	<input type="text"/>	<input type="text"/>
AC58	0010 10 Bit ST 0012 12 Bit ST 0013 13 Bit ST 0014 14 Bit ST 1212 12 Bit MT+12 Bit ST 1213 12 Bit MT+13 Bit ST 1214 12 Bit MT+14 Bit ST	E DC 10 - 30 V	S.41 Synchro, IP64, 6x10mm S.71 Synchro, IP67, 6x10mm K.42 Clamping, IP64, 10x19.5mm K.72 Clamping, IP67, 10x19.5mm K.46 Clamping, IP64, 9.52x19.5mm K.76 Clamping, IP67, 9.52x19.5mm F.42 Hubshaft with tether, IP64, 10x19.5mm hollow shaft F.47 Hubshaft with tether, IP64, 12x19.5mm hollow shaft F.46 Hubshaft with tether, IP64, 9.52x19.5mm hollow shaft Q.42 Square, IP64, 10x19.5mm Q.72 Square, IP67, 10x19.5mm Q.46 Square, IP64, 9.52x19.5mm Q.76 Square, IP67, 9.52x19.5mm	VD DeviceNet	S Bus cover with M12, 5 pole radial T Bus cover with 4 pole M12 for "tico" display + 2 sealed cable exits Z Bus cover with 2 sealed cable exits
Preferably available versions are printed in bold type.					



- Resolution programmable (K3)
- Resolution up to 24 Bit
- Preset (K3)
- Direction (K3)
- Option: display „tico“
- Diagnostic LED

TECHNICAL DATA mechanical

Housing diameter	58 mm
Protection class shaft input	IP64 or IP67
Protection class housing	Connection bus cover IP67 Connection cable IP64 (IP67 optional)
Flange	Synchro flange, clamping flange, hubshaft with tether, square flange
Shaft diameter	Solid shaft 6 mm, 10 mm; hub shaft 10 mm, 12mm
Max. speed	12 000 min ⁻¹ (short term), 10 000 min ⁻¹ (continuous)
Starting torque	≤ 0.5 Ncm
Moment of inertia	3.8 10 ⁻⁶ kgm ²
Spring tether (hollow shaft)	
Tolerance axial	± 1.5 mm
Tolerance radial	± 0.2 mm
Max. shaft load	axial 40 N / radial 60 N
Vibration resistance (IEC 68-2-6)	100 m/s ² (10 - 500 Hz)
Shock resistance (IEC 68-2-27)	1000 m/s ² (6 ms)
Operating temperature	-40...+70 °C
Storage temperature	-40...+85 °C
Material shaft	Stainless steel
Material housing	Aluminium
Weight approx.	350 g (ST), 400 g (MT)

TECHNICAL DATA electrical

Supply voltage	DC 10 - 30 V
Max. current w/o load; recommended external fuse	220 mA/250 mA; T 0.25 A
current with looped through voltage supply; recommended external fuse	max. 4.5 A for bus cover with double conin, max. 2 A for all other connections; T 4.5 A bus cover with with double conin, T 2 A for all other connections
EMC	Interference emission according to EN 50081-2 Interference resistance according to EN 50082-2
Interface	Remote installation bus
Protocol	Interbus with ENCOM Profile K3 (parameterizable), K2
General design	as per EN 61010-Part 1, protection class III, contamination level 2, overvoltage class II
Linearity	± ½ LSB
Output code	32 Bit Binary
Baud rate	500 KBaud
Updating of values	every 600 µs

TECHNICAL DATA electrical (continued)

Resolution singleturn	10 - 12 Bit
Resolution multiturn	12 Bit
Programmable	Direction, Preset, Offset, Resolution
Connection	Bus cover with: · 3 sealed cable exits · double conin 9 pole Cable radial and axial

DIMENSIONAL DRAWINGS

see chapter "Dimensional drawings ACURO industry", starting page 146

DATA FORMAT INTERBUS K2/K3

	Differential signals (RS 485)				
	ENCOM profile K3, K2, 32 Bit, binary process data				
Data format	Sµpi-address	0	1	2	3
(as per Phoenix)	Byte-No.	3	2	1	0
ID-Code K2	36H (= 54 decimal)				
ID-Code K3	37H (= 55 decimal)				

Host at AC 58

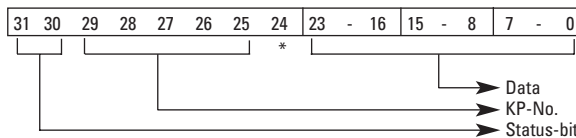

AC 58 at Host

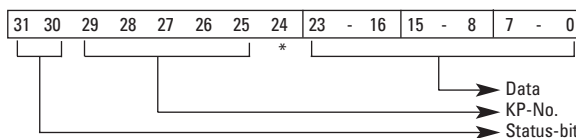

* Bit 24 not used

PROGRAMMABLE FUNCTIONS FOR INTERBUS K3

Function (Programming directly via the bus through transfer of configuration parameters)	Preset values (manufacturer's standard settings)	Customer-specific parameters
Code sequence for clockwise (cw) rotation	ascending	
Offset (KP-No. 05)	0	
Preset value (KP-No. 04)	0	
Scaling faktor (KP-No. 08)	1 ¹	

¹ maximum Resolution

PIN ASSIGNMENT

Cable with Conin 12 pole
(Standard according to ENCOM
for remote installation bus)

Plug pin	Signal
1	D02
2	$\overline{D02}$
3	DI 2
4	$\overline{DI2}$
5	D01
6	$\overline{D01}$
7	DI 1
8	$\overline{DI1}$
9	\overline{RBST}
10	0 V (supply voltage)
11	GND- signal output ¹
12	DC 10 - 30 V

¹ Due to electrical isolation not identical with 0 V (supply voltage) identisch;
used by T-manifold to set the RBST input logical on „0“

PIN ASSIGNMENT

Bus cover with double conin
(Standard according to ENCOM
for remote installation bus)

Pin	IN (9 pole pins)	OUT (9 pole socket)
1	D01	D02
2	$\overline{D01}$	$\overline{D02}$
3	DI 1	DI 2
4	$\overline{DI1}$	$\overline{DI2}$
5	GND- signal output ¹	GND- signal output ¹
6	PE ²	PE ²
7	DC 10 - 30 V (SELV)	DC 10 - 30 V (SELV)
8	0 V (supply voltage)	0 V (supply voltage)
9	N.C.	\overline{RBST}

¹ Due to electrical isolation not identical with 0 V (supply voltage) identisch;
used by T-manifold to set the RBST input logical on „0“

² Functional earthing; connected with the encoder housing

PIN ASSIGNMENT

Bus cover with 3 sealed cable exits

Connection clamp (12 pole)	
1	UB +
2	GND
3	DI1+
4	DI1-
5	D01+
6	D01-
7	D02+
8	D02-
9	DI2+
10	DI2-
11	[RBST
12	[GND-

ACCESSORIES

	Ordering code
Technical manual, German	2 565 217 www.hengstler.com
Clamping eccentric for synchro flange	0 070 655
Diaphragm coupling (hub 6/6 mm)	3 520 081
Diaphragm coupling (hub 10/10 mm)	3 520 088
Mating connector for connection I (Bus input, 9 pole, bushing, cw)	3 539 294
Mating connector for connection I (Bus output, 9 pole, pins, cw)	3 539 293

ORDERING INFORMATION

Type	Resolution	Supply voltage	Flange, Protection, Shaft	Interface	Connection
<input type="text"/>	<input type="text"/>	<input type="text"/>	<input type="text"/>	<input type="text"/>	<input type="text"/>
AC58	0010 10 Bit ST 0012 12 Bit ST 1212 12 Bit ST+12 Bit MT	E DC 10 - 30 V	S.41 Synchro, IP64, 6x10mm S.71 Synchro, IP67 ¹ , 6x10mm K.42 Clamping, IP64, 10x19.5mm K.72 Clamping, IP67 ¹ , 10x19.5mm K.46 Clamping, IP64, 9.52x19.5mm K.76 Clamping, IP67 ¹ , 9.52x19.5mm F.42 Hubshaft with tether, IP64, 10x19.5mm hollow shaft F.47 Hubshaft with tether, IP64, 12x19.5mm hollow shaft F.46 Hubshaft with tether, IP64, 9.52x19.5mm hollow shaft Q.42 Square, IP64, 10x19.5mm Q.72 Square, IP67 ¹ , 10x19.5mm Q.46 Square, IP64, 9.52x19.5mm Q.76 Square, IP67 ¹ , 9.52x19.5mm	I3 Interbus K3 I2 Interbus K2	A-B5-C Cable axial with conin connector at the 1.5m cable B-B5-C Cable radial with conin connector at the 1.5m cable I Bus cover with double conin Z Bus cover with 3 sealed cable exits
¹ Protection class IP67 not available in combination with LED display for connection with cable Preferably available versions are printed in bold type.					



AC 58 with hub shaft



AC 58 with solid shaft

- Compact design
- SUCOnet or Hengstler-G1-Protocol
- Parameterizable: preset, direction, scaling factor, resolution
- PC communication via RS 485 with Hengstler-G1-Protocol

TECHNICAL DATA mechanical

Housing diameter	58mm
Shaft	one sided open hub shaft, Vollwelle
Flange	Synchro flange, clamping flange, hubshaft with tether, square flange
Shaft diameter	Solid shaft 6 mm, 10 mm; hub shaft 10 mm, 12mm
Protection class shaft input	IP64 or IP67
Protection class housing	IP64
Max. shaft load axial/ radial	40/ 60 N
Starting torque	≤ 0,5 Ncm
Max. speed	12 000 min ⁻¹ (short term) 10 000 min ⁻¹ (continuous)
Operating temperature	-10...+60 °C
Storage temperature	-25...+85 °C
Shock resistance	1 000 m/ s ²
Vibration resistance	100 m/ s ²
Material shaft	Stainless steel
Material housing	Aluminium
Weight ST/MT	260g/ 310g

TECHNICAL DATA electrical

Supply voltage	DC 10 - 30 V
Max. current w/o load	200 mA
EMC	Interference emission according to EN 50081-2 Interference resistance according to EN 50082-2
Interface	RS485
Protocol	SUCOnet or Hengstler-G1-Protocol
Resolution singleturn	10 - 13 Bit
Resolution multiturn	12 Bit
Output code	Binary
Linearity	± ½ LSB (± 1 LSB for resolution 13 and 25 Bit)
Device address	set via DIP switches
Bus termination resistor	set via DIP switches
Programmable (SUCOnet)	Direction, Resolution
Connection	Cable radial or axial

DIMENSIONAL DRAWINGS

see chapter "Dimensional drawings ACURO industry", starting page 146

PIN ASSIGNMENT

Colour	Signal
red	DC 10 - 30 V
blue	0 V
pink	Data (in)
grey	$\overline{\text{Data}}$ (in)
yellow	Data (out)
green	$\overline{\text{Data}}$ (out)
white brown	GND

ACCESSORIES

	Ordering code
Technical manual, German	2 547 080
Technical manual, English	2 547 081

ORDERING INFORMATION

Type	Resolution	Supply voltage	Flange, Protection, Shaft	Interface	Connection
<input type="checkbox"/>	<input type="checkbox"/>	<input type="checkbox"/>	<input type="checkbox"/>	<input type="checkbox"/>	<input type="checkbox"/>
AC58	0010 10 Bit ST 0012 12 Bit ST 0013 13 Bit ST 1210 12 Bit MT+10 Bit ST 1212 12 Bit MT+12 Bit ST 1213 12 Bit MT+13 Bit ST	E DC 10 - 30 V	S.41 Synchro, IP64, 6x10mm K.42 Clamping, IP64, 10x19,5mm K.46 Clamping, IP64, 9,52x19,5mm F.42 Hubshaft with tether, IP64, 10x19,5mm, hollow shaft F.47 Hubshaft with tether, IP64, 12x19,5mm, hollow shaft F.46 Hubshaft with tether, IP64, 9,52x19,5mm, hollow shaft Q.42 Square, IP64, 10x19,5mm Q.46 Square, IP64, 9,52x19,5mm	US SUCOnet RS Hengstler-G1-Protocol	A cable, axial B cable, radial
Preferably available versions are printed in bold type.					



- Compact design: 59 mm length for single or multiturn
- Aids for start up and operation: diagnostic LED, preset key with optical response, status information
- Parameterization: Resolution, code type, direction, output format, warning, alarm
- Parameters can be stored in a non-volatile memory
- Integrated RS232 interface

TECHNICAL DATA mechanical

Housing diameter	58 mm
Protection class shaft input	IP64 or IP67
Protection class housing	IP64 (IP67 optional)
Flange	Synchro flange, clamping flange, hubshaft with tether, square flange
Shaft diameter	Solid shaft 6 mm, 10 mm; hub shaft 10 mm, 12mm
Max. speed	12 000 min ⁻¹ (short term), 10 000 min ⁻¹ (continuous)
Starting torque	≤ 0.5 Ncm
Moment of inertia	3.8 · 10 ⁻⁶ kgm ²
Spring tether (hollow shaft)	
Tolerance axial	±1.5 mm
Tolerance radial	±0.2 mm
Max. shaft load	axial 40 N / radial 60 N
Vibration resistance (IEC 68-2-6)	100 m/s ² (10 - 500 Hz)
Shock resistance (IEC 68-2-27)	1 000 m/s ² (6 ms)
Operating temperature	-40...+70 °C
Storage temperature	-40...+85 °C
Material shaft	Stainless steel
Material housing	Aluminium
Weight approx. ST/MT	260g/ 310g

TECHNICAL DATA electrical

Supply voltage	DC 10 - 30 V
Max. current w/o load ST/MT	max. 250 mA
Interface	SSI programmable
Lines / drivers	Clock and Data / RS422
Output code	Binary or Gray
Resolution singleturn	10 - 17 Bit
Resolution multiturn	12 Bit
Parameterization	Resolution, code type, direction, output format, warning, alarm
Control input	Direction, Preset 1, Preset 2
Alarm output	Alarm bit
Status LED	Green = ok; red = alarm
Connection	Cable radial or axial Conin radial or axial

Absolute Shaft Encoders

Type AC 58

ACURO industry

SSI programmable

RECOMMENDED DATA TRANSFER RATE FOR SSI

The max. data transfer rate depends on the cable length.
For Clock/ Clock and Data/ Data please use twisted pairs. Use shielded cable.

Cable length	Baud rate
< 50 m	< 400 kHz
< 100 m	< 300 kHz
< 200 m	< 200 kHz
< 400 m	< 100 kHz

SYNCHRONOUS-SERIAL TRANSFER (SSI)

A clock brush is applied at the SSI interface, causing the encoder data to be serially clocked out. With each new clock brush (min. interval 30 ms) new data is readout.

The following main parameters are programmable:

- **Preset:** Software-Preset and via input/pushbutton settable presets (can be inactivated)
- **Offset:** Relative shifting of actual encoder value.
- **Scaling:** The actual value of the encoder is multiplied with the factor < 1.
Direct entry, increments per measuring distance or per revolution.

- **Direction of rotation:** Can be changed via software or input (can be inactivated)
- **Output formats SSI:** Tree format or standard format (MSB oriented)
- **Output code:** The choices are Gray or binary code, integer or two's complement representation. Selection of significant bit between 16 and 24 Bit.

In addition, programming of max. 7 status bits is possible:

- up to 4 warning positions
- overspeed
- encoder standstill
- parity
- encoder error
- direction of rotation

PROGRAMMING WITH SSI

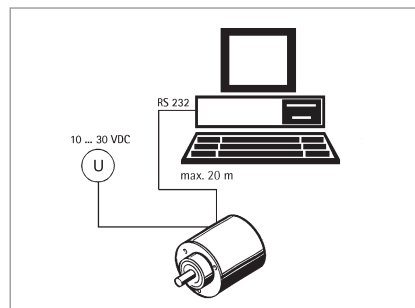

To program the absolute encoder you require a PC, the software WinSSI and the adapter cable.

The encoder is connected to the power supply and the serial interface of your PC with the adapter cable.

Using the menu-assisted programme you can then configure the encoder according to the parameters you require.

OUTPUT FORMATS SSI

MSB-oriented Multiturn

Number of data bits	Clock pulse	1	2	3	4	5	6	7	8	9	10	11	12	13	14	15	16	17	18	19	20	21	22	23	24	! Status bits 7...1
		M24	M23	M22	M21	M20	M19	M18	M17	M16	M15	M14	M13	M12	M11	M10	M9	M8	M7	M6	M5	M4	M3	M2	M1	
24		M11	M10	M9	M8	M7	M6	M5	M4	M3	M2	M1	M0	S11	S10	S9	S8	S7	S6	S5	S4	S3	S2	S1	S0	
23		M10	M9	M8	M7	M6	M5	M4	M3	M2	M1	M0	S11	S10	S9	S8	S7	S6	S5	S4	S3	S2	S1	S0	0	
22		M9	M8	M7	M6	M5	M4	M3	M2	M1	M0	S11	S10	S9	S8	S7	S6	S5	S4	S3	S2	S1	S0	0	0	
21		M8	M7	M6	M5	M4	M3	M2	M1	M0	S11	S10	S9	S8	S7	S6	S5	S4	S3	S2	S1	S0	0	0	0	
20		M7	M6	M5	M4	M3	M2	M1	M0	S11	S10	S9	S8	S7	S6	S5	S4	S3	S2	S1	S0	0	0	0	0	
19		M6	M5	M4	M3	M2	M1	M0	S11	S10	S9	S8	S7	S6	S5	S4	S3	S2	S1	S0	0	0	0	0	0	
18		M5	M4	M3	M2	M1	M0	S11	S10	S9	S8	S7	S6	S5	S4	S3	S2	S1	S0	0	0	0	0	0	0	
17		M4	M3	M2	M1	M0	S11	S10	S9	S8	S7	S6	S5	S4	S3	S2	S1	S0	0	0	0	0	0	0	0	
16		M3	M2	M1	M0	S11	S10	S9	S8	S7	S6	S5	S4	S3	S2	S1	S0	0	0	0	0	0	0	0	0	
15		M2	M1	M0	S11	S10	S9	S8	S7	S6	S5	S4	S3	S2	S1	S0	0	0	0	0	0	0	0	0	0	
14		M1	M0	S11	S10	S9	S8	S7	S6	S5	S4	S3	S2	S1	S0	0	0	0	0	0	0	0	0	0	0	
13		M0	S11	S10	S9	S8	S7	S6	S5	S4	S3	S2	S1	S0	0	0	0	0	0	0	0	0	0	0	0	
12		S11	S10	S9	S8	S7	S6	S5	S4	S3	S2	S1	S0	0	0	0	0	0	0	0	0	0	0	0	0	
11		S10	S9	S8	S7	S6	S5	S4	S3	S2	S1	S0	0	0	0	0	0	0	0	0	0	0	0	0	0	
10		S9	S8	S7	S6	S5	S4	S3	S2	S1	S0	0	0	0	0	0	0	0	0	0	0	0	0	0	0	
9		S8	S7	S6	S5	S4	S3	S2	S1	S0	0	0	0	0	0	0	0	0	0	0	0	0	0	0	0	

MSB-oriented

Multiturn (not scaleable)

Number of data bits	Clock pulse																																
	1	2	3	4	5	6	7	8	9	10	11	12	13	14	15	16	17	18	19	20	21	22	23	24	25	26	27	28	29	30	31	32	
32	M11	M10	M9	M8	M7	M6	M5	M4	M3	M2	M1	M0	S19	S18	S17	S16	S15	S14	S13	S12	S11	S10	S9	S8	S7	S6	S5	S4	S3	S2	S1	S0	
32	M10	M9	M8	M7	M6	M5	M4	M3	M2	M1	M0	S20	S19	S18	S17	S16	S15	S14	S13	S12	S11	S10	S9	S8	S7	S6	S5	S4	S3	S2	S1	S0	
32	M9	M8	M7	M6	M5	M4	M3	M2	M1	M0	S21	S20	S19	S18	S17	S16	S15	S14	S13	S12	S11	S10	S9	S8	S7	S6	S5	S4	S3	S2	S1	S0	
31	M8	M7	M6	M5	M4	M3	M2	M1	M0	S21	S20	S19	S18	S17	S16	S15	S14	S13	S12	S11	S10	S9	S8	S7	S6	S5	S4	S3	S2	S1	S0	0	
30	M7	M6	M5	M4	M3	M2	M1	M0	S21	S20	S19	S18	S17	S16	S15	S14	S13	S12	S11	S10	S9	S8	S7	S6	S5	S4	S3	S2	S1	S0	0	0	
29	M6	M5	M4	M3	M2	M1	M0	S21	S20	S19	S18	S17	S16	S15	S14	S13	S12	S11	S10	S9	S8	S7	S6	S5	S4	S3	S2	S1	S0	0	0	0	
28	M5	M4	M3	M2	M1	M0	S21	S20	S19	S18	S17	S16	S15	S14	S13	S12	S11	S10	S9	S8	S7	S6	S5	S4	S3	S2	S1	S0	0	0	0	0	
27	M4	M3	M2	M1	M0	S21	S20	S19	S18	S17	S16	S15	S14	S13	S12	S11	S10	S9	S8	S7	S6	S5	S4	S3	S2	S1	S0	0	0	0	0	0	
26	M3	M2	M1	M0	S21	S20	S19	S18	S17	S16	S15	S14	S13	S12	S11	S10	S9	S8	S7	S6	S5	S4	S3	S2	S1	S0	0	0	0	0	0	0	
25	M2	M1	M0	S21	S20	S19	S18	S17	S16	S15	S14	S13	S12	S11	S10	S9	S8	S7	S6	S5	S4	S3	S2	S1	S0	0	0	0	0	0	0	0	
24	M1	M0	S21	S20	S19	S18	S17	S16	S15	S14	S13	S12	S11	S10	S9	S8	S7	S6	S5	S4	S3	S2	S1	S0	0	0	0	0	0	0	0	0	
23	M0	S21	S20	S19	S18	S17	S16	S15	S14	S13	S12	S11	S10	S9	S8	S7	S6	S5	S4	S3	S2	S1	S0	0	0	0	0	0	0	0	0	0	
22	S21	S20	S19	S18	S17	S16	S15	S14	S13	S12	S11	S10	S9	S8	S7	S6	S5	S4	S3	S2	S1	S0	0	0	0	0	0	0	0	0	0	0	
21	S20	S19	S18	S17	S16	S15	S14	S13	S12	S11	S10	S9	S8	S7	S6	S5	S4	S3	S2	S1	S0	0	0	0	0	0	0	0	0	0	0	0	0
20	S19	S18	S17	S16	S15	S14	S13	S12	S11	S10	S9	S8	S7	S6	S5	S4	S3	S2	S1	S0	0	0	0	0	0	0	0	0	0	0	0	0	0
19	S18	S17	S16	S15	S14	S13	S12	S11	S10	S9	S8	S7	S6	S5	S4	S3	S2	S1	S0	0	0	0	0	0	0	0	0	0	0	0	0	0	0
18	S17	S16	S15	S14	S13	S12	S11	S10	S9	S8	S7	S6	S5	S4	S3	S2	S1	S0	0	0	0	0	0	0	0	0	0	0	0	0	0	0	0
17	S16	S15	S14	S13	S12	S11	S10	S9	S8	S7	S6	S5	S4	S3	S2	S1	S0	0	0	0	0	0	0	0	0	0	0	0	0	0	0	0	0
16	S15	S14	S13	S12	S11	S10	S9	S8	S7	S6	S5	S4	S3	S2	S1	S0	0	0	0	0	0	0	0	0	0	0	0	0	0	0	0	0	0
15	S14	S13	S12	S11	S10	S9	S8	S7	S6	S5	S4	S3	S2	S1	S0	0	0	0	0	0	0	0	0	0	0	0	0	0	0	0	0	0	0
14	S13	S12	S11	S10	S9	S8	S7	S6	S5	S4	S3	S2	S1	S0	0	0	0	0	0	0	0	0	0	0	0	0	0	0	0	0	0	0	0
13	S12	S11	S10	S9	S8	S7	S6	S5	S4	S3	S2	S1	S0	0	0	0	0	0	0	0	0	0	0	0	0	0	0	0	0	0	0	0	0
12	S11	S10	S9	S8	S7	S6	S5	S4	S3	S2	S1	S0	0	0	0	0	0	0	0	0	0	0	0	0	0	0	0	0	0	0	0	0	0
11	S10	S9	S8	S7	S6	S5	S4	S3	S2	S1	S0	0	0	0	0	0	0	0	0	0	0	0	0	0	0	0	0	0	0	0	0	0	0
10	S9	S8	S7	S6	S5	S4	S3	S2	S1	S0	0	0	0	0	0	0	0	0	0	0	0	0	0	0	0	0	0	0	0	0	0	0	0
9	S8	S7	S6	S5	S4	S3	S2	S1	S0	0	0	0	0	0	0	0	0	0	0	0	0	0	0	0	0	0	0	0	0	0	0	0	0

Tree format

Number of data bits multi-turn	Clock pulse																																Number of data bits single-turn
	1	2	3	4	5	6	7	8	9	10	11	12	13	14	15	16	17	18	19	20	21	22	23	24	25	...							
12	M11	M10	M9	M8	M7	M6	M5	M4	M3	M2	M1	M0	S11	S10	S9	S8	S7	S6	S5	S4	S3	S2	S1	S0	0	12	Number of data bits single-turn						
11	0	M10	M9	M8	M7	M6	M5	M4	M3	M2	M1	M0	S10	S9	S8	S7	S6	S5	S4	S3	S2	S1	S0	0	0	11							
10	0	0	M9	M8	M7	M6	M5	M4	M3	M2	M1	M0	S9	S8	S7	S6	S5	S4	S3	S2	S1	S0	0	0	0	10							
9	0	0	0	M8	M7	M6	M5	M4	M3	M2	M1	M0	S8	S7	S6	S5	S4	S3	S2	S1	S0	0	0	0	0	9							
8	0	0	0	0	M7	M6	M5	M4	M3	M2	M1	M0	S7	S6	S5	S4	S3	S2	S1	S0	0	0	0	0	0	8							
7	0	0	0	0	0	M6	M5	M4	M3	M2	M1	M0	S6	S5	S4	S3	S2	S1	S0	0	0	0	0	0	0	7							
6	0	0	0	0	0	0	M5	M4	M3	M2	M1	M0	S5	S4	S3	S2	S1	S0	0	0	0	0	0	0	0	6							
5	0	0	0	0	0	0	0	M4	M3	M2	M1	M0	S4	S3	S2	S1	S0	0	0	0	0	0	0	0	0	5							
4	0	0	0	0	0	0	0	0	M3	M2	M1	M0	S3	S2	S1	S0	0	0	0	0	0	0	0	0	0	4							
3	0	0	0	0	0	0	0	0	0	M2	M1	M0	S2	S1	S0	0	0	0	0	0	0	0	0	0	0	3							
2	0	0	0	0	0	0	0	0	0	0	M1	M0	S1	S0	0	0	0	0	0	0	0	0	0	0	0	2							
1	0	0	0	0	0	0	0	0	0	0	0	M0	S0	0	0	0	0	0	0	0	0	0	0	0	0	1							
0	0	0	0	0	0	0	0	0	0	0	0	0	0	0	0	0	0	0	0	0	0	0	0	0	0	0							

Data multiturn
(number of revolutions)
Data singleturn
(Resolution per revolution)

PIN ASSIGNMENT

Cable Colour	Conin Pin	Signal
green	1	Clock
yellow	2	clock
pink	3	Data
grey	4	Data
brown	5	RS 232 TxD
white	6	RS 232 RxD
black	7	0 V-signal output
blue	8	Direction
red	9	Preset 1
violet	10	Preset 2
white ¹	11	DC 10 - 30 V
brown ¹	12	0 V (supply voltage)

¹ thick wires 0.5 mm²

ACCESSORIES

	Ordering code
Position indication signo-SSI	see chapter "Accessories" (page 236)
User manual SSI-P, German	2 565 287 (Web)
User manual SSI-P, English	2 565 289 (Web)
Clamping eccentric for synchro flange	0 070 655
Diaphragm coupling (hub 6/6 mm)	3 520 081
Diaphragm coupling (hub 10/10 mm)	3 520 088
Software Win SSI as download from our homepage	www.hengstler.com
Win SSI PC connecting cable, incl. power pack 230 VA, for CONIN 12 pole, CCW (suited for supply voltage E and connection G or H)	1 543 010

ORDERING INFORMATION

Type	Resolution	Supply voltage	Flange, Protection, Shaft	Interface	Connection
AC58	0010 10 Bit ST 0012 12 Bit ST 0013 13 Bit ST 0014 14 Bit ST 0017 17 Bit ST 1212 12 Bit MT+12 Bit ST 1213 12 Bit MT+13 Bit ST 1214 12 Bit MT+14 Bit ST 1217 12 Bit MT+17 Bit ST *	E DC 10 - 30 V	S.41 Synchro, IP64, 6x10mm S.71 Synchro, IP67 ¹ , 6x10mm K.42 Clamping, IP64, 10x19.5mm K.72 Clamping, IP67 ¹ , 10x19.5mm K.46 Clamping, IP64, 9.52x19.5mm K.76 Clamping, IP67 ¹ , 9.52x19.5mm F.42 Hubshaft with tether, IP64, 10x19.5mm hollow shaft F.47 Hubshaft with tether, IP64, 12x19.5mm hollow shaft F.46 Hubshaft with tether, IP64, 9.52x19.5mm hollow shaft Q.42 Square, IP64, 10x19.5mm Q.72 Square, IP67 ¹ , 10x19.5mm Q.46 Square, IP64, 9.52x19.5mm Q.76 Square, IP67 ¹ , 9.52x19.5mm	SP SSI programmable	G Conin 12 pole axial ccw H Conin 12 pole radial ccw

¹ Protection class IP67 not available in combination with preset key and LED display

* higher resolution on request

Preferably available versions are printed in bold type.

Absolute Shaft Encoders Type AC 58

ACURO industry Dimensional drawings

SYNCHRO FLANGE

Anschluss: M23-Conin-Stecker / Connection: M23 connector

Schnittstelle/Interface:
BISS
SSI
ST-Parallel

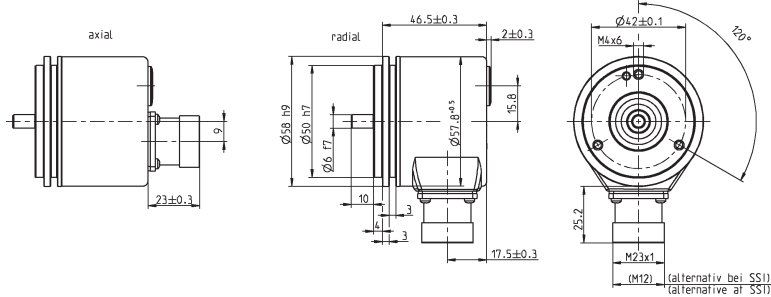

Schnittstelle/Interface:
Feldbus/Fieldbus
SSI-P

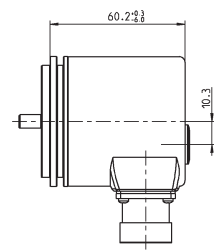

Anschluss: Kabel / Connection: cable

Schnittstelle/Interface:
BISS
SSI
ST-Parallel

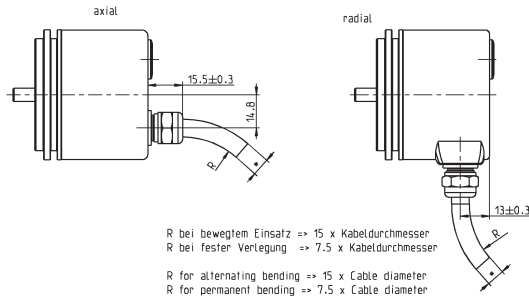

Schnittstelle/Interface:
MT-Parallel
Feldbus/Fieldbus
SSI-P

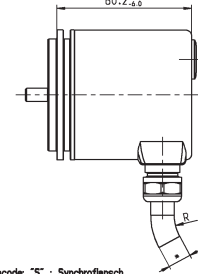

R bei bewegtem Einsatz => 15 x Kabeldurchmesser
R bei fester Verlegung => 7.5 x Kabeldurchmesser
R for alternating bending => 15 x Cable diameter
R for permanent bending => 7.5 x Cable diameter

- BiSS/SSI/SSI-P: Ø7.1^{-1.2}
- ST-P: Ø7.8^{-0.9}
- MT-P: Ø9.3^{-1.3}
- Feldbus/Fieldbus: Ø7.1^{-1.2}

Flanschcode 'S': Synchroflansch
Flange code 'S': Synchro flange

Dimensions in mm

CLAMPING FLANGE

Anschluss: M23-Conin-Stecker / Connection: M23 connector

Schnittstelle/Interface:
BISS
SSI
ST-Parallel

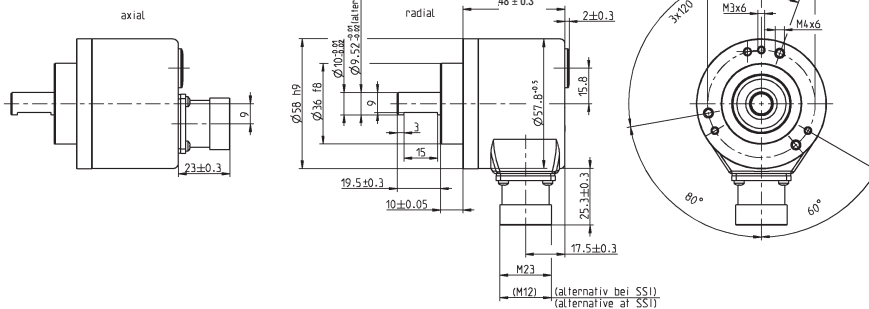

Schnittstelle/Interface:
Feldbus/Fieldbus
SSI-P

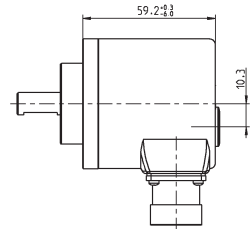

Anschluss: Kabel / Connection: cable

Schnittstelle/Interface:
BISS
SSI
ST-Parallel

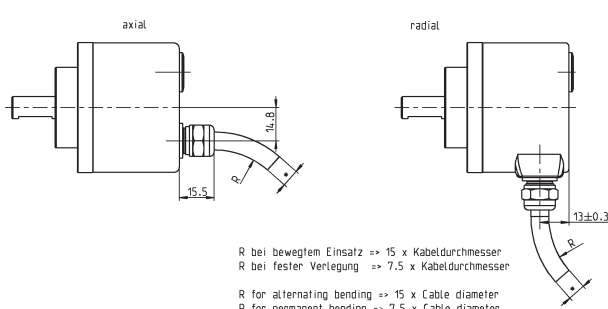

Schnittstelle/Interface:
MT-Parallel
Feldbus/Fieldbus
SSI-P

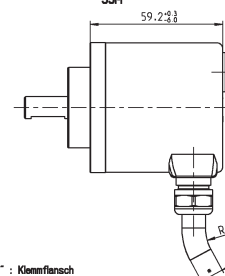

R bei bewegtem Einsatz => 15 x Kabeldurchmesser
R bei fester Verlegung => 7.5 x Kabeldurchmesser
R for alternating bending => 15 x Cable diameter
R for permanent bending => 7.5 x Cable diameter

- BiSS/SSI/SSI-P: Ø7.1^{-1.2}
- ST-P: Ø7.8^{-0.9}
- MT-P: Ø9.3^{-1.3}
- Feldbus/Fieldbus: Ø7.1^{-1.2}

Flanschcode 'K': Klemmflansch
Flange code 'K': Clamping flange

Dimensions in mm

HOLLOW SHAFT

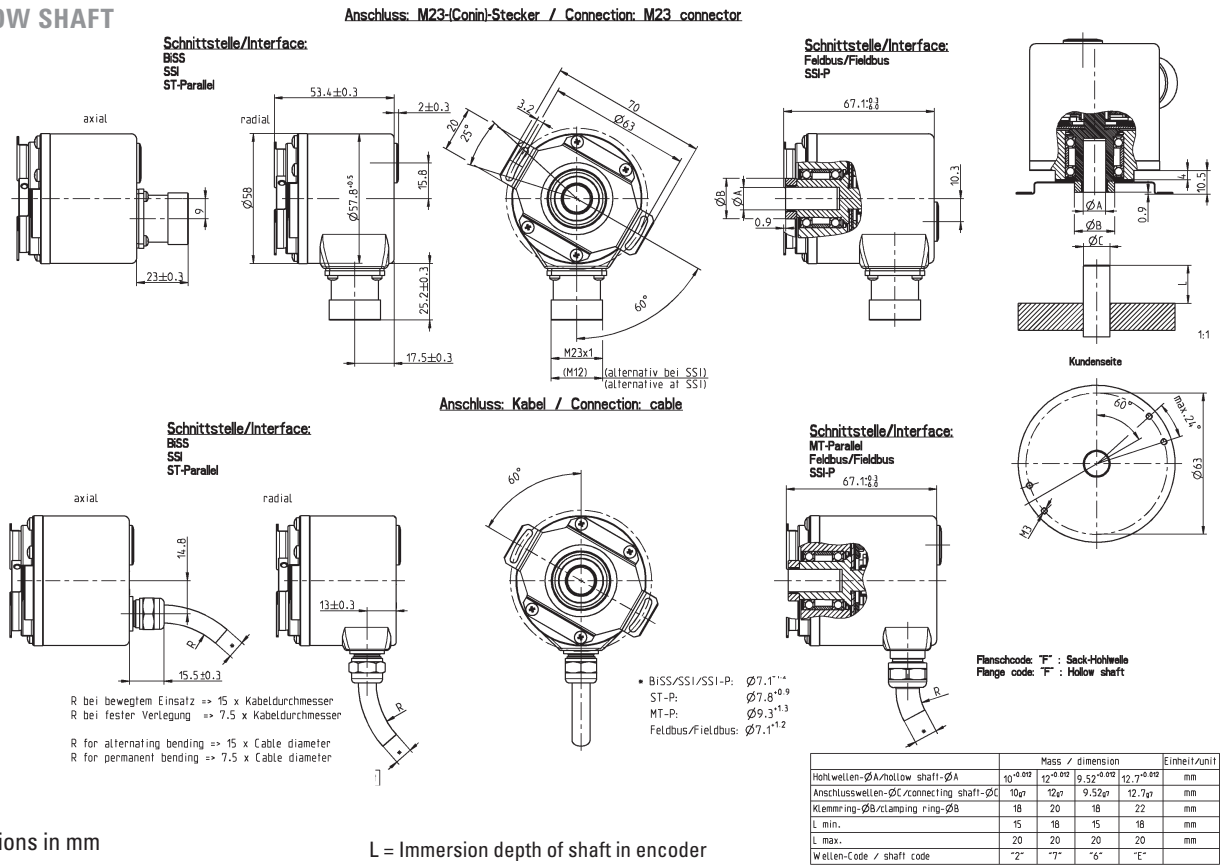

SQUARE FLANGE

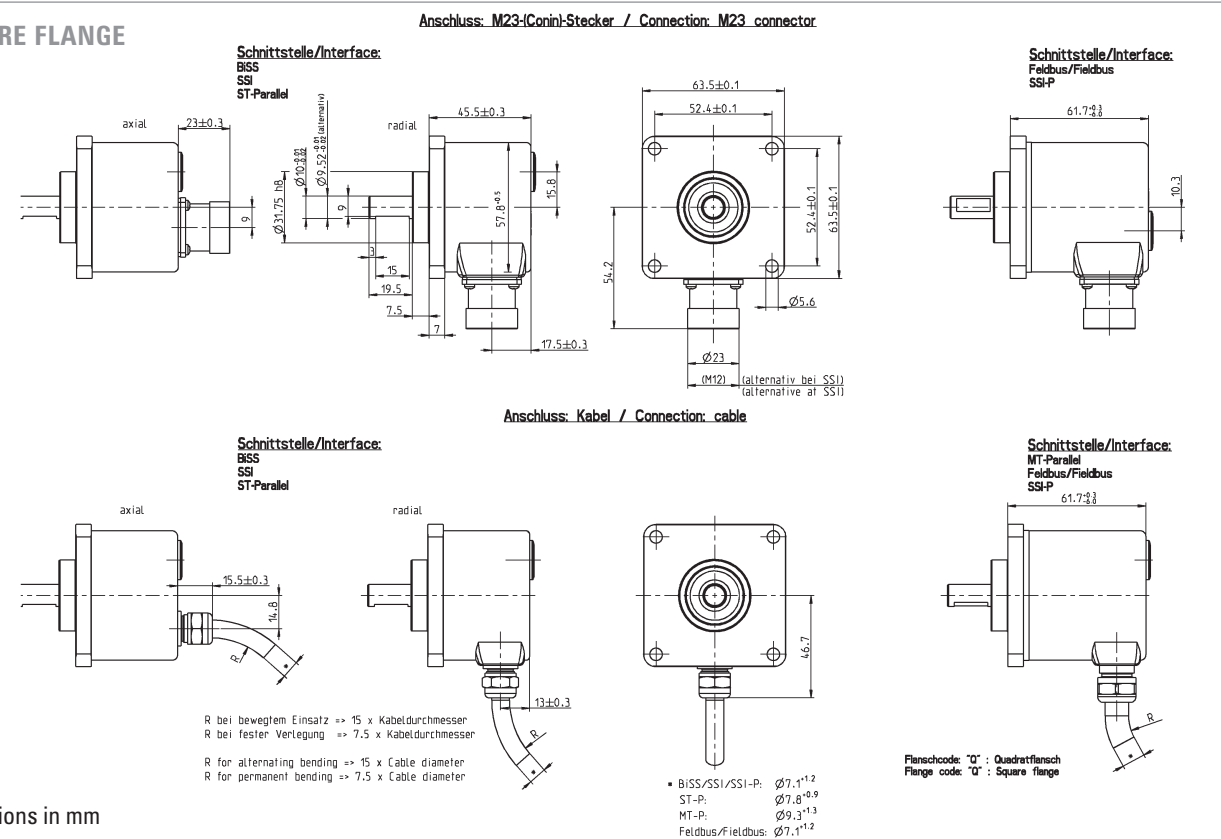

BUS COVERS

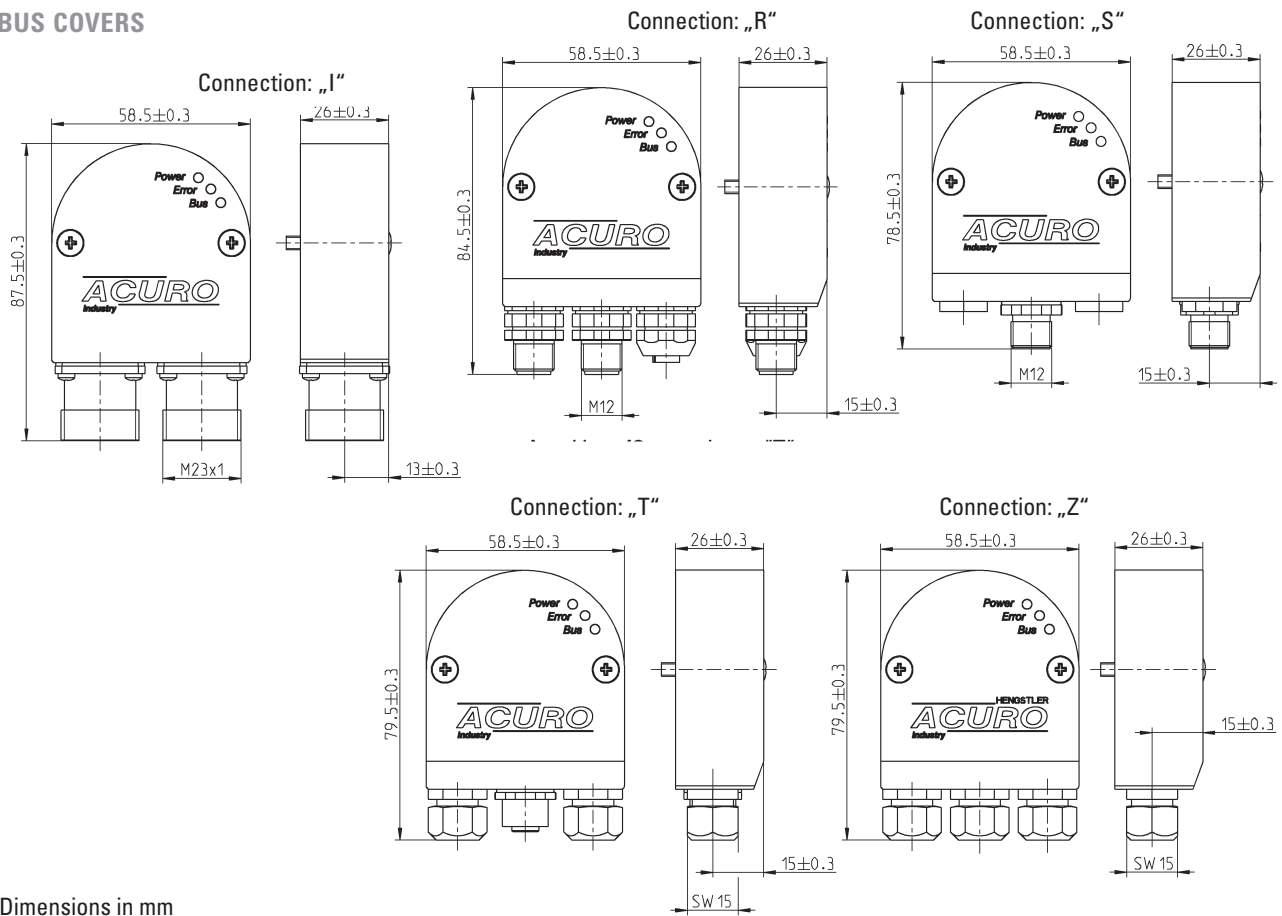

Dimensions in mm

SYNCHRO FLANGE („S“)

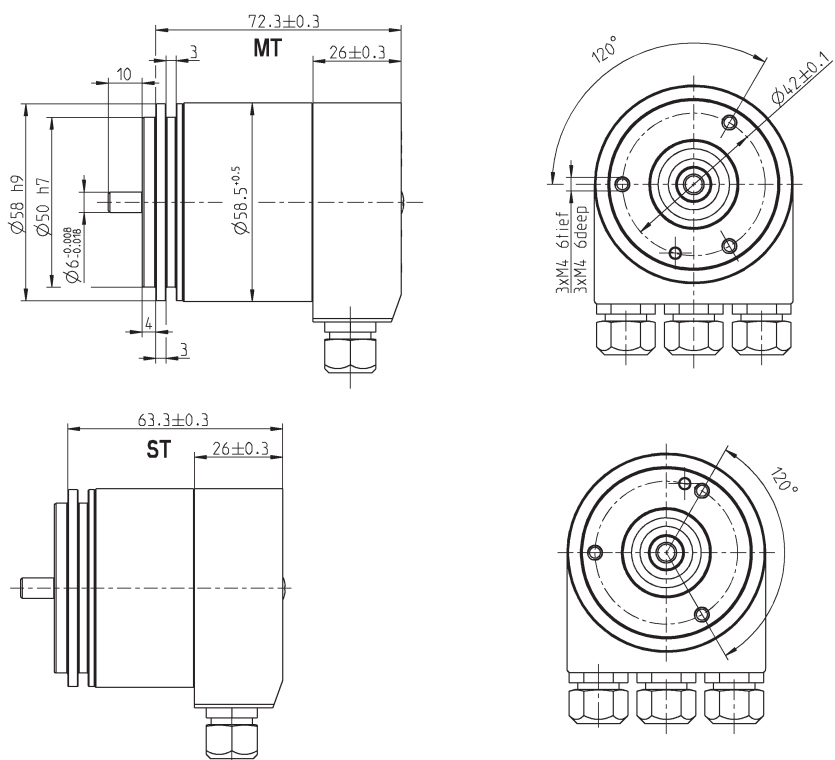

Dimensions in mm

CLAMPING FLANGE („K“)

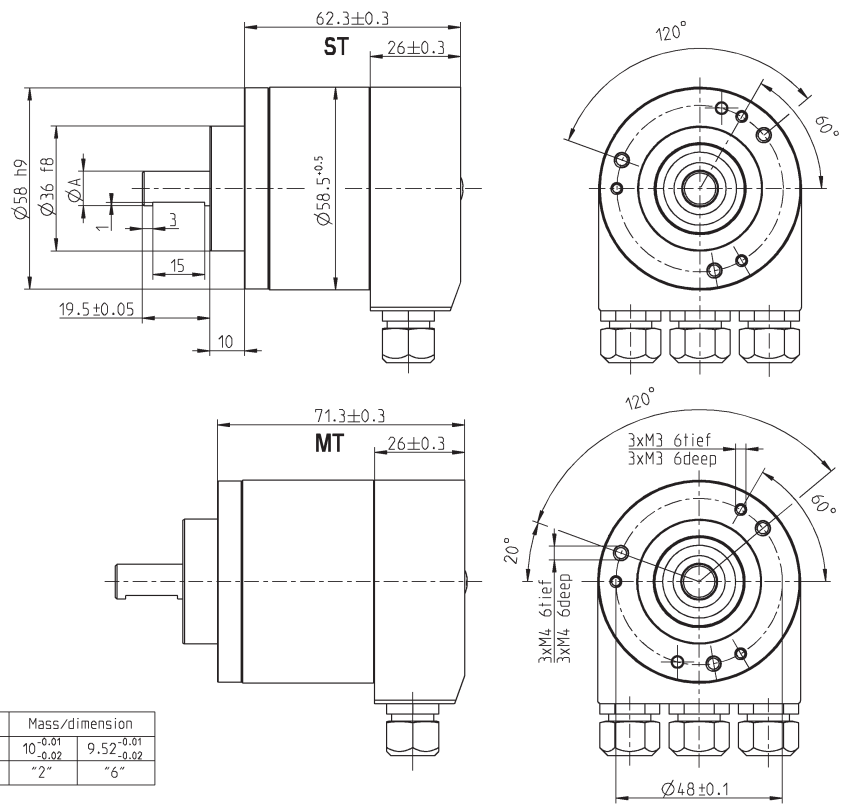

Dimensions in mm

HOLLOW SHAFT („F“)

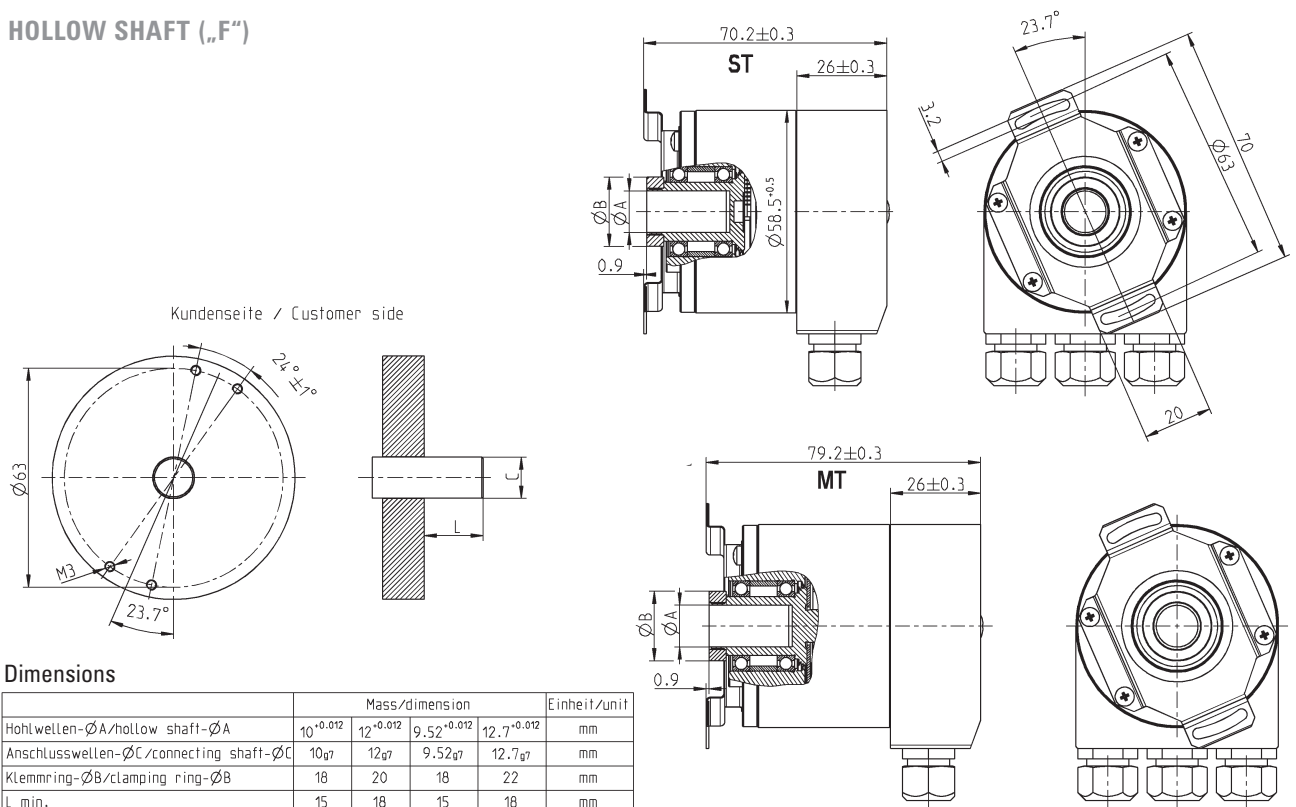

Dimensions

	Mass/dimension				Einheit/unit
Hohlwellen- \varnothing A/hollow shaft- \varnothing A	10 ^{-0.012}	12 ^{-0.012}	9.52 ^{-0.012}	12.7 ^{-0.012}	mm
Anschlusswellen- \varnothing C/connecting shaft- \varnothing C	10 _{g7}	12 _{g7}	9.52 _{g7}	12.7 _{g7}	mm
Klemmring- \varnothing B/clamping ring- \varnothing B	18	20	18	22	mm
L min.	15	18	15	18	mm
L max.	20	20	20	20	mm
Wellen-Code / shaft code	"2"	"7"	"6"	"E"	

L = Immersion depth of shaft in encoder

Dimensions in mm

SQUARE FLANGE ("Q")

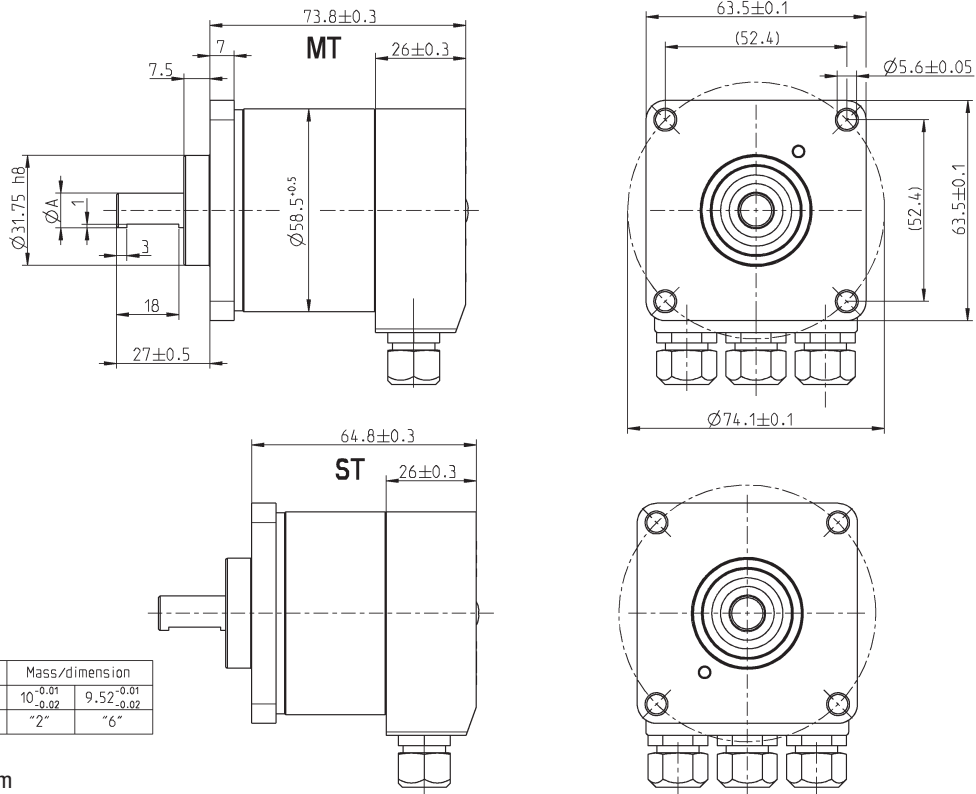

Dimensions in mm

PRELIMINARY



GENERAL INFORMATION

TECHNICAL DATA mechanical

Absolute Shaft Encoders

Type AC 110

ACURO industry

BiSS / SSI

- Same electrical performance as ACURO industry AC 36 and AC 58 versions
- Robust bearings for long life
- Hollow shaft up to 50 mm
- Absolute singleturn
- Revolution 11-17 Bit
- SSI or BiSS - Interface
- Optional: Sine-Cosine 4096 increments
- DC 5 V or DC 10 - 30 V
- Integrated diagnostic system

HENGSTLER OPTOASIC Technology

The central Element of the ACURO AC110 is the latest Hengstler OptoAsic technology, which offers the following key benefits.

- Outstanding reliability by reduced number of components and integrated diagnostics systems
- Aging compensation by integrated LED light regulation
- Integrated monitoring of:
 - Pollution
 - Disk damage
 - LED lifetime
 - Temperature

The ACURO AC110 is ideally suited for applications like:

- Gearless drive
- Gearless elevators
- Industrial Machinery

Housing diameter	110 mm
Shaft diameter	up to 50 mm
Protection class housing	IP50 or IP64
Protection class shaft	IP50 or IP64
Max. speed	IP50: 3 600 min ⁻¹ IP64: 1 500 min ⁻¹
Spring tether (hollow shaft)	
Tolerance axial	± 0.5 mm
Tolerance radial	± 0.05 mm
Vibration resistance (IEC 68-2-6)	100 m/ s ² (10 - 500 Hz)
Shock resistance (IEC 68-2-27)	1000 m/ s ² (6 ms)
Operating temperature	-20...+70°C
Storage temperature	-50...+80°C
Material Shaft	Stainless steel
Material Housing	Aluminium
Weight approx.	1000g

TECHNICAL DATA electrical

Supply voltage	DC 5 V (-5 %/ +10 %) or DC 10-30 V
Max. current w/o load ST/MT	120 mA
Lines / Drives	Clock and Data / RS422
Output code	Binary or Gray
Resolution singleturn	10 - 17 Bit
Incremental signals	Sine - Cosine 1 Vpp
No. of increments	4 096
3 dB limiting frequency	500 kHz
Absolute accuracy	± 35"
Repeatability	± 7"
Alarm output	alarm bit (SSI), warning bit and alarm bit (BiSS)
Connection	Cable radial Cable with Conin-Coupling

DIMENSIONAL DRAWINGS

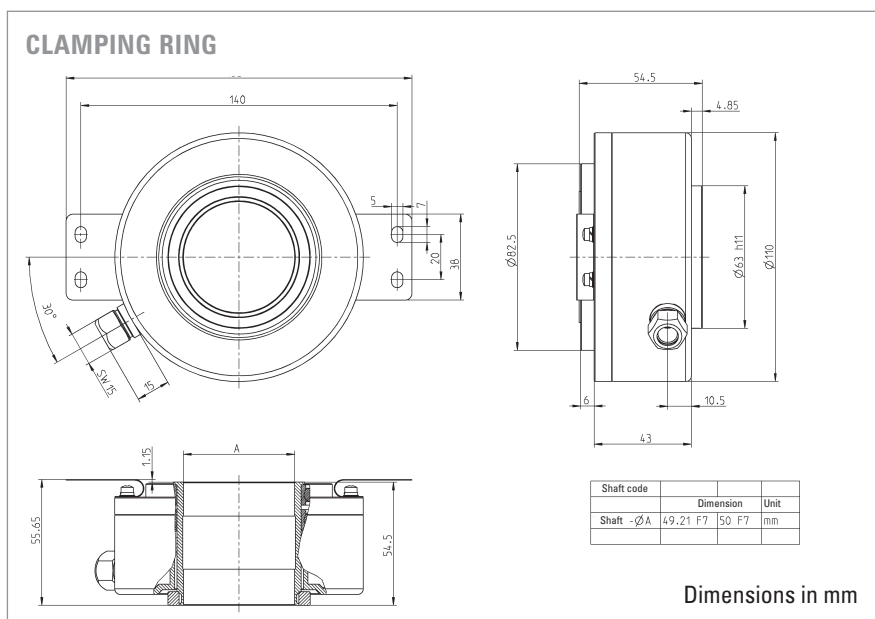
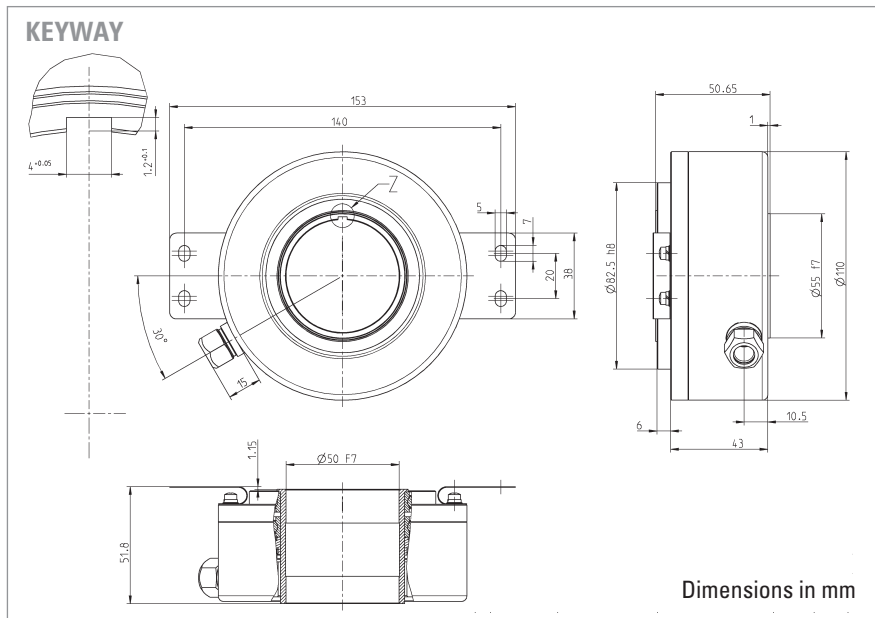

PIN ASSIGNMENT

Colour cable	Cable connector	Signal
brown ⁴	1	0V (supply voltage)
pink	2	Data
yellow	3	Clock
	4	N.C.
blue	5	Direction ¹
	6	N.C.
	7	N.C.
white ⁴	8	DC 5 V ³ / DC 10 - 30 V
	9	N.C.
grey	10	Data
green	11	Clock
black	12	0V-signal output ²
Screen		Shielded with housing

¹ Direction: + U_B or unconnected = ascending code values with rotation cw
0 V = descending code values with rotation cw

² Connected with 0 V in the encoder. Use this output to lay Direction on logical "0" if required.

³ Notice: when supply voltage = DC 5V → max. cable length 10 m

⁴ Use only thin wires 014 mm²

The max. data transfer rate depends on the cable length.

For Clock/ Clock and Data/ Data please use twisted pairs. Use shielded cable.

Lead length	Baud rate
< 50 m	< 400 kHz
< 100 m	< 300 kHz
< 200 m	< 200 kHz
< 400 m	< 100 kHz

RECOMMENDED DATA TRANSFER RATE WITH SSI

ORDERING INFORMATION

Type	Resolution	Supply voltage	Spring tether	Protection class	Mounting /Shaft	Output	Connection
<input type="checkbox"/>	<input type="checkbox"/>	<input type="checkbox"/>	<input type="checkbox"/> ■	<input type="checkbox"/>	<input type="checkbox"/>	<input type="checkbox"/>	<input type="checkbox"/>
AC110	0011 11 Bit ST 0012 12 Bit ST 0013 13 Bit ST 0014 14 Bit ST 0017 17 Bit ST ¹	A DC 5 V ² E DC 10 - 30 V	B with O without	1 IP50 4 IP64	K50 Keyway (4x1.2)/ 50 mm H50 Clamping ring/ 50 mm	SB SSI Binary SG SSI Gray BI BiSS	B Cable radial 1.5 m B-D0 Cable radial 3 m B-F0 Cable radial 5 m B-K0 Cable radial 10 m B-D Cable 1.5 m with Conin-Coupling
¹ When resolution > 14 Bit → max. Clock frequency 178 kHz ² Notice: when supply voltage = DC 5V → max. cable length 10 m							



Version AC 59 with cable outlet



Version AC 61 with bus cover or cable

TYPES

TECHNICAL DATA mechanical

TECHNICAL DATA electrical

- Compact design
- Protection class IP67
- High corrosion resistance
- Robust design
- Resolution up to 29 Bit (17 Bit ST, 12 Bit MT)
- Connection with cable or with bus cover
- Applications:
 - Packaging machine for food and beverage
 - Ship equipment (e.g. cranes, winches, cable laying ships)
 - Offshore - Applications

The absolute stainless steel encoder are available in the Versions AC 59 and AC 61

- AC 59: drawn stainless steel housing, only together with cable outlet, no access to control elements
- AC 61: massive turned housing, possible with cable or bus cover, access to control elements (DIP switch, Reset switch)

The stainless steel encoder is available with following interfaces:

- Single- or multiturn with cable radial/ axial and interfaces SSI, BiSS, Parallel, SSI-P, CANopen, CANlayer2
- Single- or multiturn with bus cover and interfaces Profibus, CANopen, CANlayer2, DeviceNet, Interbus

Flange	Square flange 63.5 x 63.5 mm
Shaft diameter	10 mm
Protection class (EN 60529)	IP67
Max. Speed	Short term: 10 000 min ⁻¹ , continuous: 6 000 min ⁻¹
Torque	< 1 Ncm
Moment or inertia	approx. 20 gcm ²
Max. shaft load	axial 40 N/ radial 60 N
Vibration proof (IEC 68-2-6)	100 m/ s ² (10 - 500 Hz)
Shock resistance (IEC 68-2-27)	1000 m/ s ² (6 ms)
Operating temperature	SSI, BiSS, Parallel, : -40...+100°C SSI-P, Interbus: -40...+70°C Profibus, CANopen, CANlayer2, DeviceNet: -40...+ 85°C
Storage temperature	-40...+ 85°C
Material Shaft/ Housing	Stainless steel
Weight approx.	AC 59 with 1.5 m cable: 700 g AC 61 with 1.5 m cable: 980 g AC 61 with bus cover (MT): 1 180 g

The electrical data and pin assignment see for:

- BiSS/ SSI, page 113
- Parallel, page 118
- Profibus, page 123
- CANopen, page 127
- CANlayer2, page 130
- DeviceNet, page 133
- Interbus, page 136
- SSI-P, page 142

Absolute Shaft Encoders Type AC 59 / 61

Stainless steel

DIMENSIONAL DRAWINGS

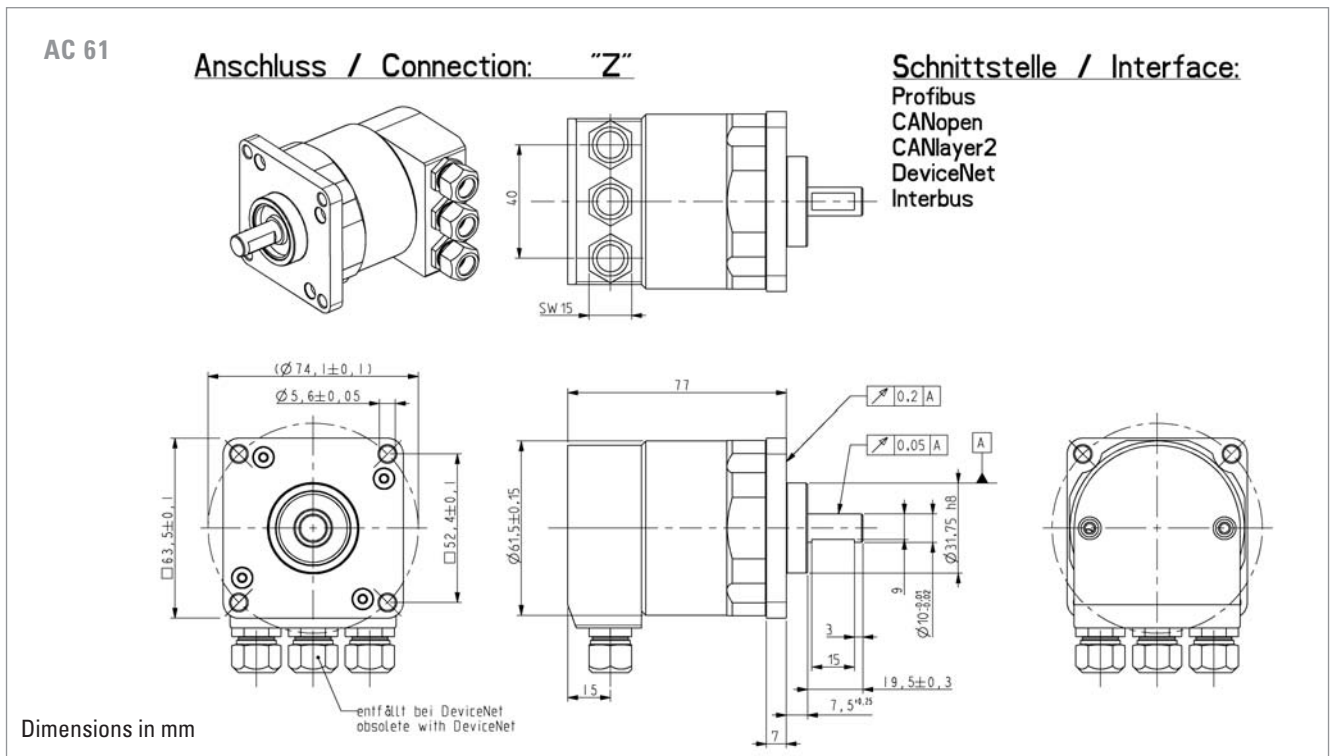
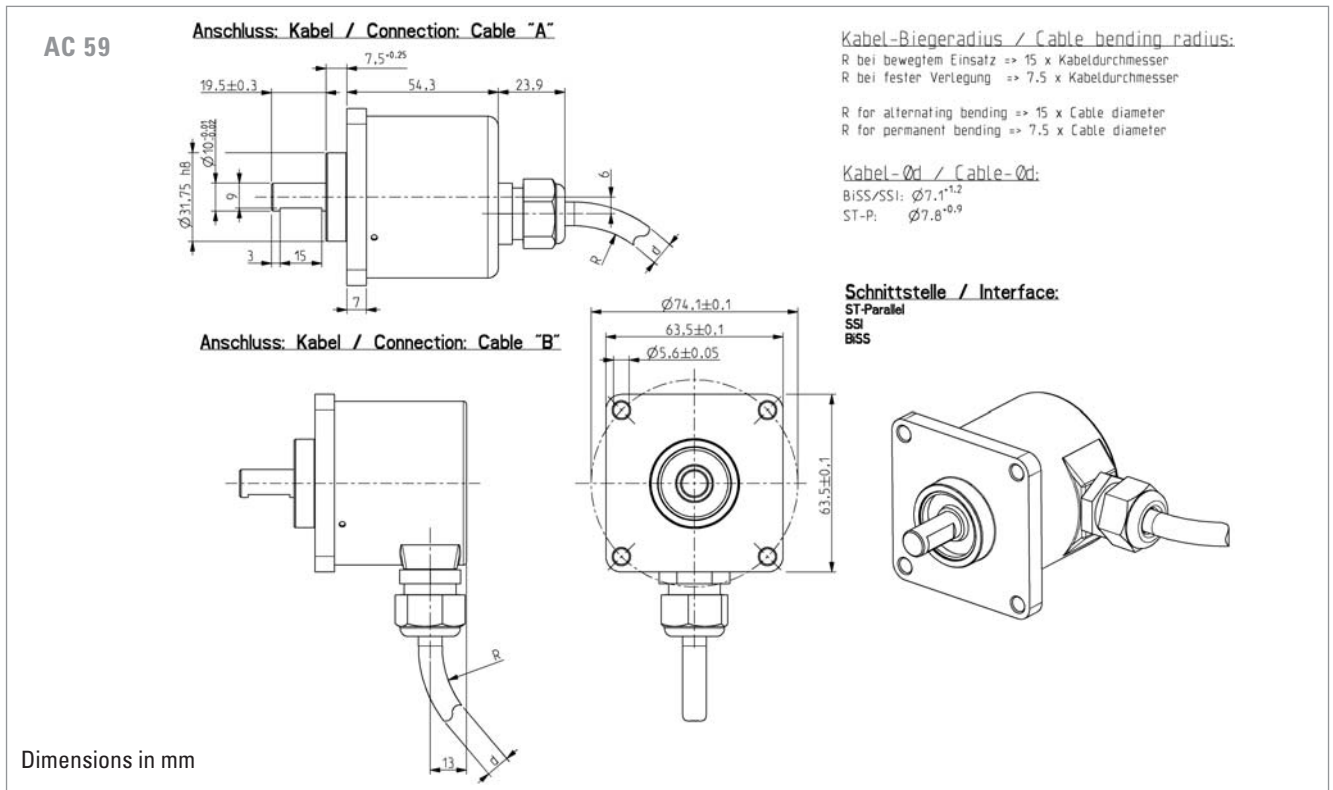

DIMENSIONAL DRAWINGS (continued)

AC 61

Anschluss: Kabel / Connection: Cable "A"

Schnittstelle / Interface:

ST-/MT-Parallel

BiSS

SSI

SSI-P

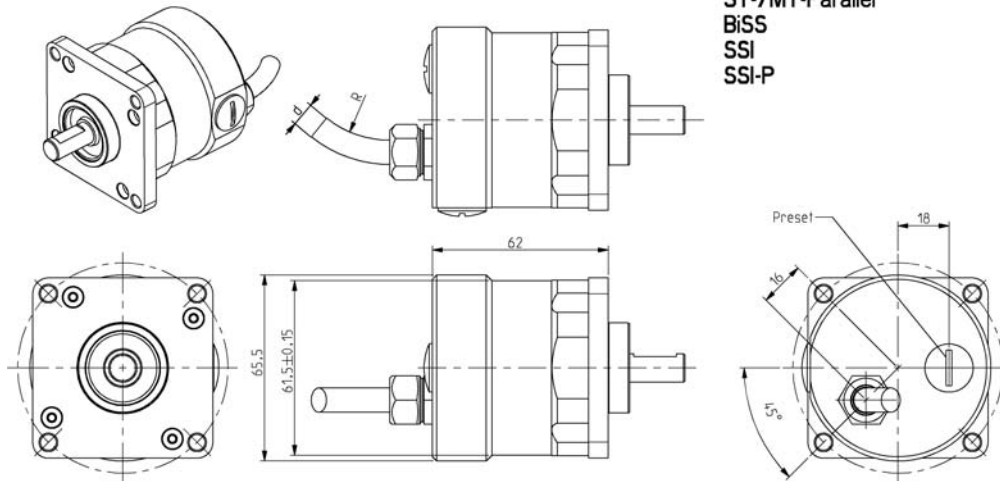

Kabel-Biegeradius / Cable bending radius:

R bei bewegtem Einsatz => 15 x Kabeldurchmesser

R bei fester Verlegung => 7.5 x Kabeldurchmesser

R for alternating bending => 15 x Cable diameter

R for permanent bending => 7.5 x Cable diameter

Kabel-Ød / Cable-Ød:

BISS/SSI/SSI-P: $\varnothing 7.1^{+1.2}$

ST-P: $\varnothing 7.8^{+0.9}$

MT-P: $\varnothing 9.3^{+1.3}$

Feldbus/Fieldbus: $\varnothing 7.1^{+1.2}$

Dimensions in mm

AC 61

Anschluss: Kabel / Connection: Cable "A"

Schnittstelle / Interface:

CANopen

CANlayer2

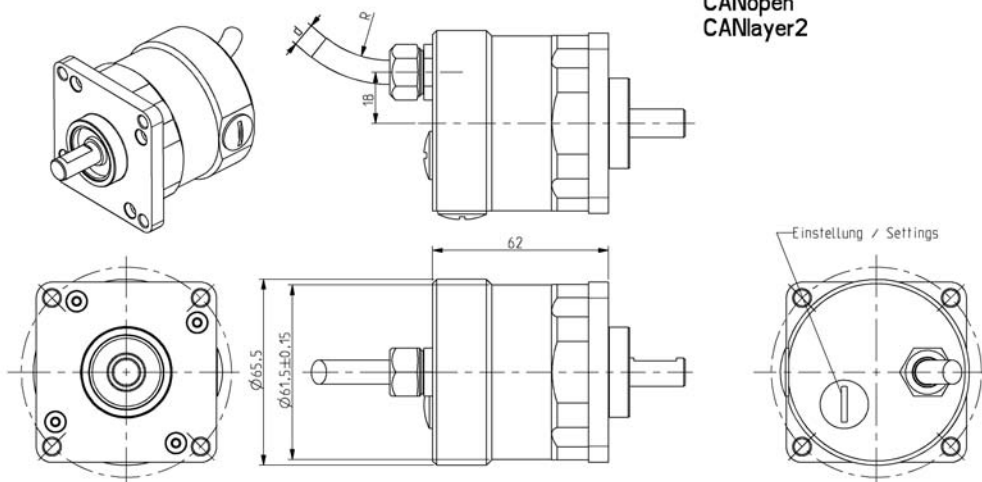

Kabel-Biegeradius / Cable bending radius:

R bei bewegtem Einsatz => 15 x Kabeldurchmesser

R bei fester Verlegung => 7.5 x Kabeldurchmesser

R for alternating bending => 15 x Cable diameter

R for permanent bending => 7.5 x Cable diameter

Kabel-Ød / Cable-Ød:

BISS/SSI/SSI-P: $\varnothing 7.1^{+1.2}$

ST-P: $\varnothing 7.8^{+0.9}$

MT-P: $\varnothing 9.3^{+1.3}$

Feldbus/Fieldbus: $\varnothing 7.1^{+1.2}$

Dimensions in mm

Absolute Shaft Encoders Type AC 59 / 61

Stainless steel

DIMENSIONAL DRAWINGS (continued)

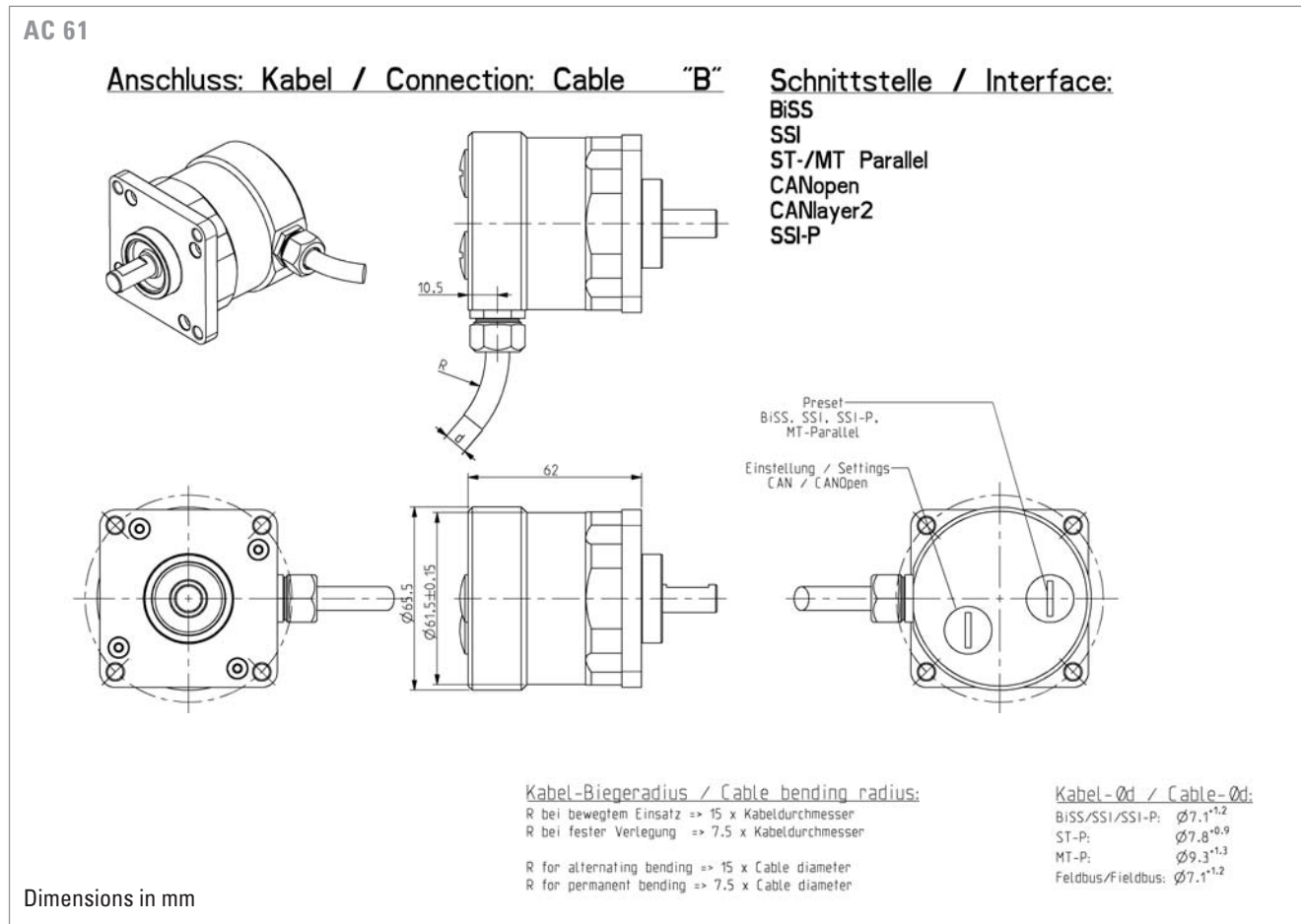

ACCESSORIES

Profibus	
GSD-file as download from our homepage	www.hengstler.com
Technical manual German	2 565 090 (or homepage)
Technical manual English	2 565 255 (or homepage)
CANopen	
EDS-file as download from our homepage	www.hengstler.com
Technical manual	2 565 250 (or homepage)
DeviceNet	
EDS-file as download from our homepage	www.hengstler.com
Technical manual German	2 565 094 (or homepage)
Technical manual English	2 565 256 (or homepage)
Interbus	
Technical manual K3 German	2 565 217 (or homepage)
SSI programmable	
Technical manual German	2 565 287 (or homepage)
Technical manual English	2 565 289 (or homepage)
Software Win SSI as download from our homepage	www.hengstler.com

ORDERING INFORMATION ACURO industry with BiSS

Type	Resolution	Supply voltage	Flange, Protection, Shaft	Output	Connection
<input type="checkbox"/>	<input type="checkbox"/>	<input type="checkbox"/>	<input type="checkbox"/>	<input type="checkbox"/>	<input type="checkbox"/>
AC59	0010 10 Bit ST 0012 12 Bit ST 0013 13 Bit ST 0014 14 Bit ST 0017 17 Bit ST 0360 360 Incr. ST ¹ 0720 720 Incr. ST ² 1212 12 Bit MT+12 Bit ST 1213 12 Bit MT+13 Bit ST 1214 12 Bit MT+14 Bit ST 1217 12 Bit MT+17 Bit ST	A DC 5 V E DC 10 - 30 V	Q.72 Square flange, IP67, 10x19.5 mm Q.76 Square flange, IP67, 9.52x19.5 mm	BI BiSS (Digital) BC BiSS (+SinCos 1Vpp)	A Cable axial 1.5 m A-FO Cable axial 5 m A-KO Cable axial 10 m B Cable radial 1.5 m B-FO Cable radial 5 m B-KO Cable radial 10 m
¹ with Offset 76 (value range 76...435) ² with Offset 152 (value range 152...871)					

ORDERING INFORMATION ACURO industry with SSI

Type	Resolution	Supply voltage	Flange, Protection, Shaft	Output	Connection
<input type="checkbox"/>	<input type="checkbox"/>	<input type="checkbox"/>	<input type="checkbox"/>	<input type="checkbox"/>	<input type="checkbox"/>
AC59	0010 10 Bit ST 0012 12 Bit ST 0013 13 Bit ST 0014 14 Bit ST 0017 17 Bit ST 0360 360 Incr. ST ¹ 0720 720 Incr. ST ² 1212 12 Bit MT+12 Bit ST 1213 12 Bit MT+13 Bit ST	A DC 5 V E DC 10 - 30 V	Q.72 Square flange, IP67, 10x19.5 mm Q.76 Square flange, IP67, 9.52x19.5 mm	SB SSI Binary SG SSI Gray SC SSI Gray (+SinCos 1Vpp)	A Cable axial 1.5 m A-FO Cable axial 5 m A-KO Cable axial 10 m B Cable radial 1.5 m B-FO Cable radial 5 m B-KO Cable radial 10 m
¹ with Offset 76 (value range 76...435) ² with Offset 152 (value range 152...871)					

Absolute Shaft Encoders Type AC 59 / 61

Stainless steel

ORDERING INFORMATION ACURO industry with Parallel

Type	Resolution	Supply voltage	Flange, Protection, Shaft	Output	Connection
<input type="checkbox"/>	<input type="checkbox"/>	<input type="checkbox"/>	<input type="checkbox"/>	<input type="checkbox"/>	<input type="checkbox"/>
AC59 * AC61	0010 10 Bit ST 0012 12 Bit ST 0013 13 Bit ST 0014 14 Bit ST 0017 17 Bit ST 0360 360 Incr. ST ¹ 0720 720 Incr. ST ² 0412 04 Bit MT+12 Bit ST 0812 08 Bit MT+12 Bit ST 1212 12 Bit MT+12 Bit ST	E DC 10 - 30 V	Q.72 Square flange, IP67, 10x19.5 mm Q.76 Square flange, IP67, 9.52x19.5 mm	PB Parallel Binary PG Parallel Gray	A Cable axial 1.5 m A-F0 Cable axial 5 m A-KO Cable axial 10 m B Cable radial 1.5 m B-F0 Cable radial 5 m B-KO Cable radial 10 m
* only with ST ¹ with Offset 76 (value range 76...435) ² with Offset 152 (value range 152...871)					

ORDERING INFORMATION ACURO industry with Profibus

Type	Resolution	Supply voltage	Flange, Protection, Shaft	Output	Connection
<input type="checkbox"/>	<input type="checkbox"/>	<input type="checkbox"/>	<input type="checkbox"/>	<input type="checkbox"/>	<input type="checkbox"/>
AC61	0010 10 Bit ST 0012 12 Bit ST 0013 13 Bit ST 0014 14 Bit ST 1212 12 Bit MT+12 Bit ST 1213 12 Bit MT+13 Bit ST 1214 12 Bit MT+14 Bit ST	E DC 10 - 30 V	Q.72 Square flange, IP67, 10x19.5 mm Q.76 Square flange, IP67, 9.52x19.5 mm	DP Profibus	Z Bus terminal box with 3x screwed cable gland

ORDERING INFORMATION ACURO industry with CANopen / CANlayer2

Type	Resolution	Supply voltage	Flange, Protection, Shaft	Output	Connection
<input type="checkbox"/>	<input type="checkbox"/>	<input type="checkbox"/>	<input type="checkbox"/>	<input type="checkbox"/>	<input type="checkbox"/>
AC61	0010 10 Bit ST 0012 12 Bit ST 0013 13 Bit ST 0014 14 Bit ST 1212 12 Bit MT+12 Bit ST 1213 12 Bit MT+13 Bit ST 1214 12 Bit MT+14 Bit ST	E DC 10 - 30 V	Q.72 Square flange, IP67, 10x19.5 mm Q.76 Square flange, IP67, 9.52x19.5 mm	OL CANopen CL CANlayer2	A Cable axial 1.5 m A-F0 Cable axial 5 m A-KO Cable axial 10 m B Cable radial 1.5 m B-F0 Cable radial 5 m B-KO Cable radial 10 m Z Bus terminal box with 3x screwed cable gland

ORDERING INFORMATION

ACURO industry with DeviceNet

Type	Resolution	Supply voltage	Flange, Protection, Shaft	Output	Connection
<input type="checkbox"/>	<input type="checkbox"/>	<input type="checkbox"/>	<input type="checkbox"/>	<input type="checkbox"/>	<input type="checkbox"/>
AC61	0010 10 Bit ST 0012 12 Bit ST 0013 13 Bit ST 0014 14 Bit ST 1212 12 Bit MT+12 Bit ST 1213 12 Bit MT+13 Bit ST 1214 12 Bit MT+14 Bit ST	E DC 10 - 30 V	Q.72 Square flange, IP67, 10x19.5 mm Q.76 Square flange, IP67, 9.52x19.5 mm	VD DeviceNet	Z Bus terminal box with 2x screwed cable gland

ORDERING INFORMATION

ACURO industry with Interbus

Type	Resolution	Supply voltage	Flange, Protection, Shaft	Output	Connection
<input type="checkbox"/>	<input type="checkbox"/>	<input type="checkbox"/>	<input type="checkbox"/>	<input type="checkbox"/>	<input type="checkbox"/>
AC61	0010 10 Bit ST 0012 12 Bit ST 0013 13 Bit ST 0014 14 Bit ST 1212 12 Bit MT+12 Bit ST 1213 12 Bit MT+13 Bit ST 1214 12 Bit MT+14 Bit ST	E DC 10 - 30 V	Q.72 Square flange, IP67, 10x19.5 mm Q.76 Square flange, IP67, 9.52x19.5 mm	I3 Interbus K3 I2 Interbus K2	Z Bus terminal box with 3x screwed cable gland

ORDERING INFORMATION

ACURO industry with SSI programmable

Type	Resolution	Supply voltage	Flange, Protection, Shaft	Output	Connection
<input type="checkbox"/>	<input type="checkbox"/>	<input type="checkbox"/>	<input type="checkbox"/>	<input type="checkbox"/>	<input type="checkbox"/>
AC61	0010 10 Bit ST 0012 12 Bit ST 0013 13 Bit ST 0014 14 Bit ST 1212 12 Bit MT+12 Bit ST 1213 12 Bit MT+13 Bit ST 1214 12 Bit MT+14 Bit ST 1217 12 Bit MT+17 Bit ST *	E DC 10 - 30 V	Q.72 Square flange, IP67, 10x19.5 mm Q.76 Square flange, IP67, 9.52x19.5 mm	SP SSI programmable	A Cable axial 1.5 m A-F0 Cable axial 5 m A-K0 Cable axial 10 m B Cable radial 1.5 m B-F0 Cable radial 5 m B-K0 Cable radial 10 m

* higher resolution on request

Absolute Shaft Encoders Type AX 70 / 71

Explosion proof



Version AX 70 - Aluminium



Version AX 71 - Stainless steel

- ATEX certification for gas and dust explosion proof
- Same electrical performance as ACURO industry
- Protection class up to IP67
- Diameter only 70 mm
- Robust design
- Also available with stainless steel
- Resolution up to 29 Bit (17 Bit ST, 12 Bit MT)
- Applications:
 - enamelling production line
 - petro chemistry
 - bottling machines
 - mixers
 - silo works, mills
- Interfaces: SSI, SSI programmable, Profibus, CANopen



ATEX

EX-CLASSIFICATION

The absolute shaft encoder line ACURO is available in explosion proof design with explosion proof enclosure "d" under AX 70 and AX 71 (stainless steel). The PTB has assured with the Declaration of Conformity that the AX 70 / 71 meets the requirements of safety and health according to EN 50014 and EN 50018. Therefore it is approved in explosive areas, code „Ex II 2 G/D E Ex d II C T4/T6 IP65/ IP66 135°C resp. 85°C“. For applications under tough environmental conditions and food industry the stainless steel version AX 71 is available.

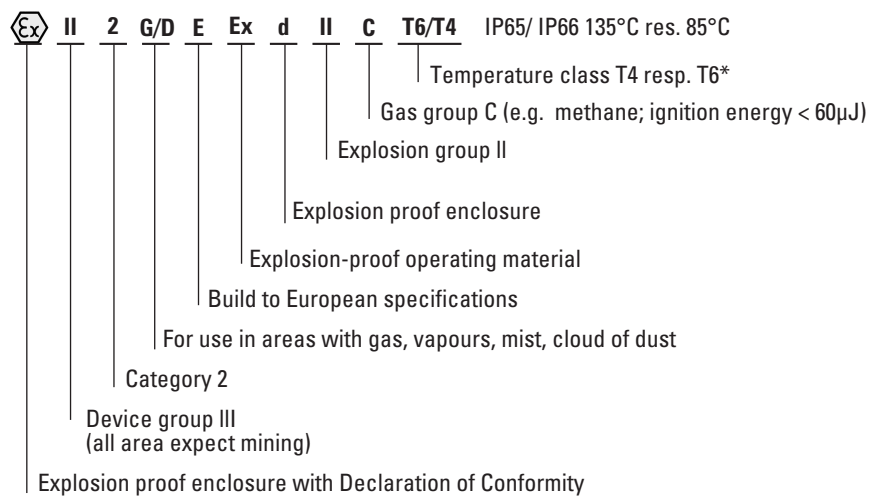

T6 = Highest permissible surface temperature +85°C (max. speed = 6000 U/min⁻¹)
 T4 = Highest permissible surface temperature +130°C(max. speed = 10000 U/min⁻¹)

Absolute Shaft Encoders

Type AX 70 / 71

Explosion proof

TECHNICAL DATA mechanical (for all interfaces)

	Temperature class T4	Temperature class T6
Housing diameter	70 mm	70 mm
Shaft diameter	10 mm	10 mm
Protection class housing	IP67 or IP65	IP65
Protection class shaft	IP67 or IP64	IP64
Max. speed	10000 min ⁻¹	6000 min ⁻¹
Torque	≤ 1 Ncm	≤ 1 Ncm
Moment of inertia	approx. 20 gcm ²	approx. 20 gcm ²
Max. shaft load	axial 40 N/ radial 100 N	axial 40 N/ radial 100 N
Vibration resistance (IEC 68-2-6)	100 m/s ² (10 - 500 Hz)	100 m/s ² (10 - 500 Hz)
Shock resistance (IEC 68-2-27)	1000 m/s ² (6 ms)	1000 m/s ² (6 ms)
Operating temperature	-40 ...+60°C	-40 ...+40°C
Storage temperature	-25...+80°C	-25...+80°C
Material shaft / housing	Aluminium (AX70) Stainless steel (AX71)	Aluminium (AX70) Stainless steel (AX71)
Weight approx. ST/MT	1 000 g (AX 70) 1 900 g (AX 71)	1 000 g (AX 70) 1 900 g (AX 71)

TECHNICAL DATA ELECTRICAL Profibus, CANopen

	Profibus	CANopen
Supply voltage	DC 10-30 V	DC 10-30 V
Max. current w/o load ST/MT	220 mA/ 250 mA	max. 250 mA
Profile/ Protocol	Profibus DP with encoder profile class C2 (programmable)	CANopen according DS 301 with encoder profile DSP 406
Output code	binary	binary
Resolution singleturn	10 - 14 Bit	10 - 14 Bit
Resolution multiturn		12 Bit
Baud rate	is automatically set within a range of 9.6 Kbit/s through 12Mbit/s	set via DIP-switches
Bus terminating resistor	external mounting	external mounting
Device address	set via Bus	-
Node ID	-	set via Bus
Integrated special functions	Speed, acceleration, operating time	Speed, acceleration, round axis, limit values operating time
Programmable	Resolution, Preset, Direction	Resolution, Preset, Limit value, Direction
Connection	Cable axial	Cable axial

PIN ASSIGNMENT Profibus, CANopen

Color	Profibus	CANopen
yellow	B in	CAN in+
green	A in	CAN in -
pink	B out	CAN out+
grey	A out	CAN out -
blue	GND1 (M5V ¹)	CAN GND in
brown	VCC1 (P5V ¹)	CAN GND out
white 0.5 mm	DC 10 ... 30 V	UB in
brown 0.5 mm	0 V	0 V in
Screen	Screen connected to encoder housing	

¹ used for power supply for an external bus termination resistor

Absolute Shaft Encoders **Type AX 70 / 71**

Explosion proof

TECHNICAL DATA ELECTRICAL SSI, SSI PROGRAMMABLE

	SSI	SSI programmable
Supply voltage	DC 10-30 V	DC 10-30 V
Max. current w/o load ST/MT	220 mA/ 250 mA	max. 250 mA
Lines / Drivers	clock and data RS422	clock and data RS422
Output code	binary or gray	binary or gray
Resolution singleturn	10 - 17 Bit	9 - 22 Bit
Resolution multiturn	12 Bit	12 Bit
Programmable (with ACURO soft + appropriate hardware)	code type, direction, warning, alarm	-
Programmable (with WIN SSI)	-	code type, direction, output code, warning, alarm
Control input	<u>Direction</u>	Direction, Preset 1, Preset 2
Alarm output	Alarm bit	Alarm bit
Connection	Cable axial	Cable axial

PIN ASSIGNMENT SSI, SSI programmable

Color	No.	SSI	SSI programmable
white 0.14 mm	6	DC 10 ... 30 V	RS232 RxD
brown 0.14 mm	5	0 V supply voltage	RS232 TxD
green	10	<u>Clock</u>	<u>Clock</u>
yellow	9	Clock	Clock
grey	8	<u>Data</u>	<u>Data</u>
pink	7	Data	Data
blue	3	<u>Direction</u>	Direction
black	4	0 V signal output	0 V signal output
red	1	-	Preset 1
violet	2	-	Preset 2
brown 0.5 mm	11	-	0 V supply voltage
white 0.5 mm	12	-	DC 10 ... 30 V
Screen		Screen connected to the housing	

RECOMMENDED DATA TRANSFER RATE WITH SSI

The max. data transfer rate depends on the cable length.
For Clock/ Clock and Data/ Data please use twisted pairs. Use shielded cable.

Lead length	Baud rate
< 50 m	< 400 kHz
< 100 m	< 300 kHz
< 200 m	< 200 kHz
< 400 m	< 100 kHz

DIMENSIONAL DRAWINGS

SSI

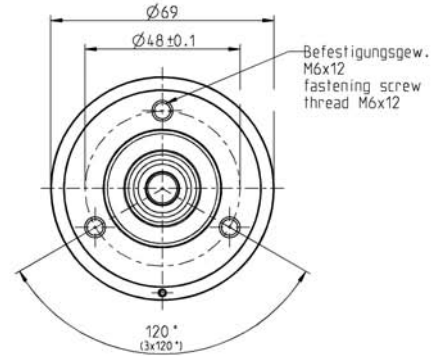
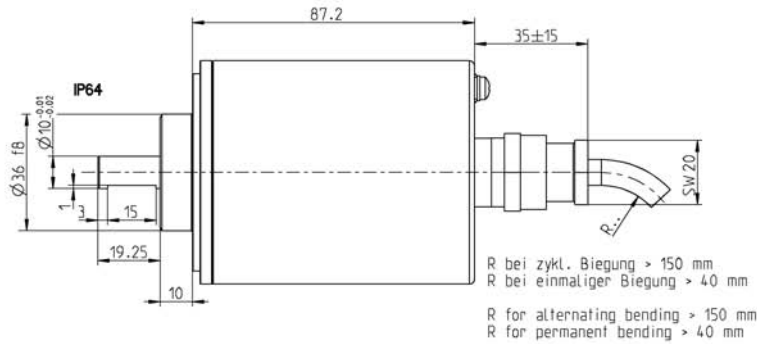

IP67

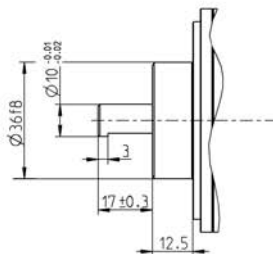

Dimensions in mm

SSI-P, Profibus,
CANopen

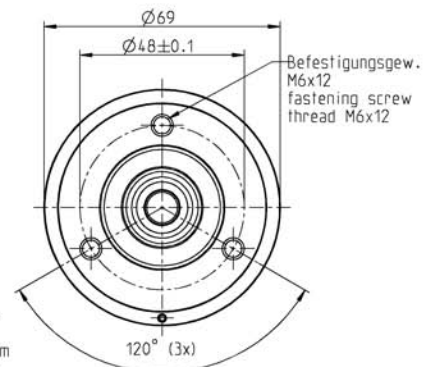
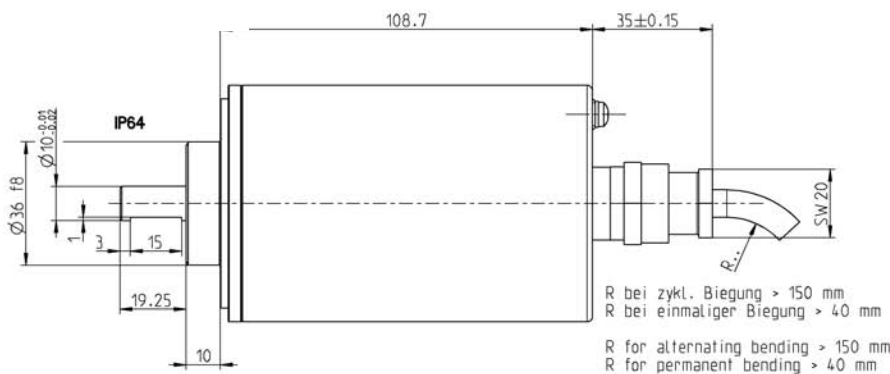

IP67

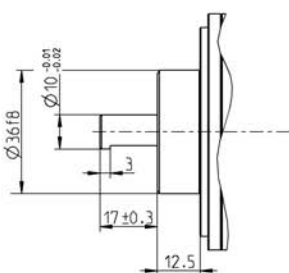

Dimensions in mm

Absolute Shaft Encoders Type AX 70 / 71

Explosion proof

ACCESSORIES

SSI	
Software ACURO soft	on request
SSI programmable	
Technical Manual German	2 565 287 (or homepage)
Technical Manual English	2 565 289 (or homepage)
Software Win SSI	on request
Profibus	
GSD-file as download from our homepage	www.hengstler.com
Technical Manual German	2 565 090 (or homepage)
Technical Manual English	2 565 255 (or homepage)
CANopen	
EDS-file as download from our homepage	www.hengstler.com
Technical Manual German	2 565 250 (or homepage)

ORDERING INFORMATION

ACURO industry with SSI

Type	Resolution	Supply voltage	Flange, Protection, Shaft	Output	Connection
<input type="checkbox"/>	<input type="checkbox"/>	<input type="checkbox"/>	<input type="checkbox"/>	<input type="checkbox"/>	<input type="checkbox"/>
AX70- Aluminum AX71- Stainless steel	0010 10 Bit ST 0012 12 Bit ST 0013 13 Bit ST 0014 14 Bit ST 0017 17 Bit ST ** 0360 360 Incr. ST ¹ 0720 720 Incr. ST ² 1212 12 Bit MT+12 Bit ST 1213 12 Bit MT+13 Bit ST higher resolutions on request	E DC 10-30 V	K.42 Clamping flange, IP64, 10x19.5 mm K.72* Clamping flange, IP67, 10x19.5 mm	SB SSI Binary SG SSI Gray	A-F0 Cable axial 5 m A-K0 Cable axial 10 m
* only with temperature class 4; IP67 is necessary for use in areas with clouds of dust ** When resolution > 14 Bit → max. clock frequency 178 kHz ¹ with Offset 76 (value range 76...435) ² with Offset 152 (value range 152...871)					

ORDERING INFORMATION

ACURO industry with SSI programmable

Type	Resolution	Supply voltage	Flange, Protection, Shaft	Output	Connection
<input type="checkbox"/>	<input type="checkbox"/>	<input type="checkbox"/>	<input type="checkbox"/>	<input type="checkbox"/>	<input type="checkbox"/>
AX70- Aluminum AX71- Stainless steel	0010 10 Bit ST 0012 12 Bit ST 0013 13 Bit ST 0014 14 Bit ST 0017 17 Bit ST 1212 12 Bit MT+12 Bit ST 1213 12 Bit MT+13 Bit ST 1214 12 Bit MT+14 Bit ST 1217 12 Bit MT+17 Bit ST higher resolutions on request	E DC 10 - 30 V	K.42 Clamping flange, IP64, 10x19.5 mm K.72* Clamping flange, IP67, 10x19.5 mm	SP SSI programmable	A-F0 Cable axial 5 m A-K0 Cable axial 10 m

* only with temperature class 4; IP67 is necessary for use in areas with clouds of dust

ORDERING INFORMATION

ACURO industry with Profibus

Type	Resolution	Supply voltage	Flange, Protection, Shaft	Output	Connection
<input type="checkbox"/>	<input type="checkbox"/>	<input type="checkbox"/>	<input type="checkbox"/>	<input type="checkbox"/>	<input type="checkbox"/>
AX70- Aluminum AX71- Stainless steel	0010 10 Bit ST 0012 12 Bit ST 0013 13 Bit ST 0014 14 Bit ST 1212 12 Bit MT+12 Bit ST 1213 12 Bit MT+13 Bit ST 1214 12 Bit MT+14 Bit ST	E DC 10 - 30 V	K.42 Clamping flange, IP64, 10x19.5 mm K.72* Clamping flange, IP67, 10x19.5 mm	DP Profibus	A-F0 Cable axial 5 m A-K0 Cable axial 10 m

* only with temperature class 4; IP67 is necessary for use in areas with clouds of dust

ORDERING INFORMATION

ACURO industry with CANopen

Type	Resolution	Supply voltage	Flange, Protection, Shaft	Output	Connection
<input type="checkbox"/>	<input type="checkbox"/>	<input type="checkbox"/>	<input type="checkbox"/>	<input type="checkbox"/>	<input type="checkbox"/>
AX70- Aluminum AX71- Stainless steel	0010 10 Bit ST 0012 12 Bit ST 0013 13 Bit ST 0014 14 Bit ST 1212 12 Bit MT+12 Bit ST 1213 12 Bit MT+13 Bit ST 1214 12 Bit MT+14 Bit ST	E DC 10 - 30 V	K.42 Clamping flange, IP64, 10x19.5 mm K.72* Clamping flange, IP67, 10x19.5 mm	OL CANopen	A-F0 Cable axial 5 m A-K0 Cable axial 10 m

* only with temperature class 4; IP67 is necessary for use in areas with clouds of dust

Motor Feedback Systems



Hengstler offers Motor Feedback systems in all performance classes and with the most commonly used interfaces

From modular miniature incremental encoders for **DC and Stepper Motors** in 22 mm diameter up to the absolute AC110 with 50mm hollow shaft Hengstler provides a complete range of Motor Feedback systems.

For asynchronous motors and elevators the offering comprises incremental and absolute hollow shaft encoders in singleturn and multiturn versions. Trend-setting is the Incremental OptoAsic with diagnosis system and integrated interpolation electronic which is for the first time used in RI80-E. This enables resolutions of up to 200 000 pulses for good synchronism of electric machines running at low revs.

For AC Servo Motors there is an extensive range of feedback products available: Brushless resolvers size 10, 15 and 21 uniquely robust and low priced, incremental comcoders for direct block commutation of BLDC motors in low cost modular version or with integrated bearings and resolutions up to 10 000 pulses per revolution.

Your application requires highest precision and dynamics? Than you are on the right track with the Sine-wave encoder S21 and the absolute Acuro-Drive encoder. Latest OptoAsic technology and a true geared multiturn provides obvious advantages regarding performance and reliability. Hengstler offers the Acuro-Drives series with the open, highspeed, digital interface BiSS. With the open source BiSS interface the proprietary lock-in situation with absolute motorfeedback systems is broken up with the benefit of an increasing range of suppliers.

One Size fits all:

No matter whether your servo application requires resolvers, incremental comcoders or absolute Multiturn encoders - the complete range in size 15 with resolver compatible mounting is available from Hengstler. The benefit of this is, that the B-side of the motor can be resolver style and doesn't need to be customized, depending on the feedback. The Feedback type can be selected according to customer demands or required resolution and technology. This helps reducing variation of parts and stock and enables improved delivery times.

Motor Feedback Systems - Kit Encoders for Miniature DC and Stepper Motors



Type	E 9	M 9	M 14
Special features	<ul style="list-style-type: none"> ■ ideal for position and speed sensing in small machines and actuators ■ low power standby mode is ideal for battery powered devices ■ 200 kHz operating frequency ■ resolution to 512 lines/rev 	<ul style="list-style-type: none"> ■ ideal for position and speed sensing in small machines and actuators ■ 200 kHz operating frequency ■ resolution to 512 lines/rev 	<ul style="list-style-type: none"> ■ ideal economical feedback device for servo and stepper motors ■ short axial length and compact 1.5 inch diameter ■ easy "snap-on" installation ■ high resolution to 1024 lines/rev and 200 kHz bandwidth ■ drop-in replacement for HP 5540
Number of pulses	100 ... 512	100 ... 512	200 ... 1 024
Commutation	None	None	None
Technical Data - mechanical			
Shaft diameter	Hollow shaft Ø 1.5 ... 4.0 mm	Hollow shaft Ø 1.5 ... 4.0 mm	Hollow shaft Ø 3.0 ... 8.0 mm
Max. speed	12 000 min ⁻¹	12 000 min ⁻¹	12 000 min ⁻¹
Protection class housing/bearing	---	---	---
Operating temperature	-40 ... + 100 °C	-40 ... + 100 °C	-40 ... + 100 °C
Diameter	22.0 mm	22.0 mm	38.0 mm
Mounting depth	20.0 mm	14.8 mm	17.2 mm
Technical Data - electrical			
Output	TTL	TTL	TTL
Supply voltage (SELV)	DC 5 V ±10 %	DC 5 V ±10 %	DC 5 V ±10 %
Max. current w/o load	10 mA, typ. Standby current: max. 50 µA	10 mA, typ.	10 mA, typ.
Max. pulse frequency	200 kHz	200 kHz	200 kHz
Max. output load	3 mA (25°C), 2 mA (100°C)	3 mA (25°C), 2 mA (100°C)	6mA (25°C) 4 mA (100°C)
Pulse shape	Square wave	Square wave	Square wave
Phasing	90°±18° electrical	90°±18° electrical	90°±18° electrical
Symmetry	180°±18° electrical	180°±18° electrical	180°±18° electrical
Page	180	183	186

Motor Feedback Systems - Hollow shaft Encoders for Asynchronous & DC Motors



Type	RI 36-H	RI 58-D	RI 58TD
Special features	<ul style="list-style-type: none"> ■ miniature industry encoder for high numbers of pulses ■ short mounting depth ■ easy mounting procedure ■ applications, e.g. motors, machine tools, packaging machines, robots, automated SMD equipment 	<ul style="list-style-type: none"> ■ direct mounting without coupling ■ flexible hollow shaft concept up to 14 mm ■ through hollow shaft or as end shaft (blind shaft) ■ easy mounting procedure with clamping flange or fastening thread ■ short mounting depth of 33 mm ■ operating temperature up to 80 °C ■ Fixing of the flange with a stator coupling or cylindrical pin ■ applications, e.g. positioning drives, motors 	<ul style="list-style-type: none"> ■ direct mounting without coupling ■ flexible hollow shaft concept up to 14 mm ■ through hollow shaft or as end shaft (blind shaft) ■ easy mounting procedure with clamping flange or fastening thread ■ short mounting depth of 33 mm ■ operating temperature up to 100 °C ■ Fixing of the flange with a stator coupling or cylindrical pin ■ applications, e.g. positioning drives, motors
Number of pulses	5 ... 3 600	1 ... 5 000	4 ... 2 500
Commutation	None	None	None
Technical Data - mechanical			
Shaft diameter	Hollow shaft 4 / 6 / 8 / 10 mm	Hollow shaft 10 mm / 12 mm / 14 mm	Hollow shaft 10 mm / 12 mm / 14 mm
Max. speed	10 000 min ⁻¹	6 000 min ⁻¹	6 000 min ⁻¹
Max. speed (continuous)			
Protection class housing/bearing	IP64/64	IP65/64	IP65/64
General design	as per DIN VDE 0160, protection class III	as per DIN VDE 0160, protection class III	as per DIN VDE 0160, protection class III
Operating temperature	-10 ... +70 °C	-10 ... +70 °C	-25 .. +100 °C
Diameter	36 mm	58 mm	58 mm
Mounting depth	39 mm	33 mm .. 50.5 mm (depends on version)	33 mm .. 50.5 mm (depends on version)
Technical Data - electrical			
Output	RS 422 / push-pull / push-pull complementary	RS 422 / push-pull / push-pull complementary	RS 422 / push-pull / push-pull complementary
Supply voltage (SELV)	DC 5 V / DC 10 - 30 V	DC 5 V / DC 10 - 30 V	DC 5 V / DC 10 - 30 V
Max. current w/o load	40 mA (DC 5 V), 30 mA (DC 24 V), 60 mA (DC 10 V)	40 mA (DC 5 V), 30 mA (DC 24 V), 60 mA (DC 10 V)	40 mA (DC 5 V), 30 mA (DC 24 V), 60 mA (DC 10 V)
Max. pulse frequency	300 kHz (RS 422) 200 kHz (push-pull)	300 kHz (RS 422) 200 kHz (push-pull)	300 kHz (RS 422) 200 kHz (push-pull)
Max. output load	RS 422: ±30 mA push-pull with short circuit protection: 30 mA (DC 10 - 30 V)	RS 422: ±30 mA push-pull with short circuit protection: 30 mA (DC 10 - 30 V)	RS 422: ±30 mA push-pull with short circuit protection: 30 mA (DC 10 - 30 V)
Pulse shape	Square wave	Square wave	Square wave
Page	62	68	68

Motor Feedback Systems - Hollow shaft Encoders for Asynchronous & DC Motors



Type	RI 76TD	RI 80-E
Special features	<ul style="list-style-type: none"> ■ through hollow shaft ■ shaft diameters 15 to 42 mm ■ external diameter only 76 mm ■ simple installation with clamping ring front or rear ■ operating temperature up to 100 °C ■ applications e.g. motors, printing machines, elevators 	<ul style="list-style-type: none"> ■ incremental Output ■ 30...45 mm hollow shaft ■ rugged mechanical design ■ unbreakable disc ■ integrated diagnostic system ■ wide voltage range DC 5 ... 30 V
Number of pulses	1 ... 10 000	1024, 2048, 4096 other number of pulses on request
Commutation	None	None
Technical Data - mechanical		
Shaft fixation	Clamping ring front or rear	Keyway, set screw
Coupling	stator coupling (hubshaft with tether)	Spring tether (single, double)
Shaft diameter	Hollow shaft 15 ... 42 mm	Hollow shaft 30 ... 45 mm
Max. speed	6 000 min ⁻¹ (depends on version)	3 600 min ⁻¹ (IP50), 1 500 min ⁻¹ (IP64)
Protection class housing/bearing	IP50/40 (Option: IP65/64)	IP50, IP64
General design	as per DIN EN 61010, protection class III, Contamination level 2, over voltage class II	as per DIN EN 61010, protection class III, Contamination level 2, over voltage class II
Operating temperature	-25 ... +100 °C	-20 ... +70 °C
Connection	Cable radial	Sub-D 15p. / cable, radial
Diameter	76 mm	
Weight	320 ... 580 g (depends on version)	1 000 g
Technical Data - electrical		
Output	RS 422/push-pull/push-pull complementary	RS 422/push-pull/push-pull complementary
Supply voltage (SELV)	DC 5V/DC 10 - 30 V	DC 5V ±10% or DC 5 - 30 V
Max. current w/o load	60 mA (DC 5V), 60 mA (DC 10 V), 35 mA (DC 24 V)	60 mA (DC 5V), 60 mA (DC 10 V), 35 mA (DC 24 V)
Max. pulse frequency	300 kHz (RS 422) 200 kHz (push-pull)	600 kHz (RS 422) 200 kHz (push-pull)
Max. output load	RS 422: ±30 mA push-pull with short circuit protection: 30 mA (DC 10 - 30 V)	RS 422: ±30 mA push-pull with short circuit protection: 40 mA (DC 5 - 30 V)
Alarm output	NPN-O.C. 5 mA	NPN-O.C. 5 mA
Pulse shape	Square wave	Square wave
Pulse duty factor	1 : 1	1 : 1
Page	74	78

Motor Feedback Systems - Hollow shaft Encoders for Asynchronous & DC Motors



Type	RIS 58-H
Special features	<ul style="list-style-type: none"> ■ harmonic distortion less than 1 % ■ extended temperature range, -40° up to +100 °C ■ 500 kHz sine-wave incremental signal frequency response ■ self-monitoring and error compensation ■ secure against short-circuit and overload
Number of pulses	1 000, 1 024, 2 048, 2 500, 5 000
Technical Data - mechanical	
Shaft diameter	10 mm, 12 mm hollow shaft
Balance tolerances	axial ±1.5 mm, radial ±0.2 mm
Max. speed	12 000 min ⁻¹
Torque	≤ 1 Ncm
Protection (EN 60529)	Bearing IP64, Housing IP65
General design	as per DIN EN 61010-1
Operating temperature	-40 ... +100 °C
Vibration (IEC 68-2-6)	≤ 100 m/s ²
Shock (IEC 68-2-27)	≤ 1 000 m/s ²
Material housing	Aluminium
Connection	Cable axial or radial Conin axial or radial
Size	Ø 58 mm
Weight approx.	270 g
Technical Data - electrical	
Supply voltage (SELV)	DC 5 V/ ±10 %
Max. current w/o load	120 mA
Incremental signals A, B	Sine - Cosine 1 Vpp
Absolute accuracy	±35"
Repeatability	±7"
Max. output frequency	500 kHz
Reference signal: R	> 0,4 V (1 pulse / turn)
Page	99

Motor Feedback Systems - Hollow shaft Encoders for Asynchronous & DC Motors



Type	AC 58 - BiSS / SSI	AC 110 - BiSS / SSI
Technical Data - mechanical		
Housing diameter	58 mm	110 mm
Shaft diameter	Hub shaft 10 mm, 12 mm	up to 50 mm
Protection class shaft input	IP64 or IP67	IP50 or IP64
Protection class housing	IP64 (IP67 optional)	IP50 or IP64
Flange	Hubshaft with tether	Hollow shaft with tether
Max. speed	Continuous: 10 000 min ⁻¹ , Short term: 12 000 min ⁻¹	IP50: 3600 min ⁻¹ IP64: 1500 min ⁻¹
Shaft load	axial 40 N / radial 60 N	
Spring tether (hollow shaft)		
Tolerance axial / radial	± 1.5 mm / ± 0.2 mm	± 0.5 mm / ± 0.05 mm
Shock resistance (IEC 68-2-27)	1 000 m/s ² (6 ms)	1000 m/ s ² (6 ms)
Vibration resistance (IEC 68-2-6)	100 m/s ² (10 ... 2 000 Hz)	100 m/ s ² (10 - 500 Hz)
Operating temperature	-40 ... 100 °C	-20 ... +70 °C
Weight approx. ST/MT	260 g / 310 g	1000 g
Technical Data - electrical		
Supply voltage	DC 5 V, -5 % / + 10 % or DC 10 - 30 V	DC 5 V (-5 % / +10 %) or DC 10-30 V
Max. current w/o load ST/MT	50 mA / 100 mA	120 mA
Interface	BiSS or Standard SSI	BiSS or Standard SSI
Lines/ Drives	Clock and Data/ RS422	Clock and Data/ RS422
Output code	Binary or Gray	Binary or Gray
Linearity	±1/2 LSB (± 1 LSB for resolution > 13 Bit)	
Resolution singleturn	10-17 Bit, Gray Excess: 360, 720 steps	10 - 17 Bit
Resolution multiturn	12 Bit	only singleturn
Optional incremental signals	Sine - Cosine 1 Vpp	Sine - Cosine 1 Vpp
Number of pulses	2048	4096
3 db limiting frequency		500 kHz
Absolute accuracy	±35"	± 35"
Repeatability	±7"	± 7"
Parameterization	Code type, sense of rotation, warning, alarm	Code type, sense of rotation, warning, alarm
Control input	Direction	Direction
Reset key	Disable via parameterization	
Alarm output	Alarm bit (SSI option), warning bit and alarm bit (BiSS)	Alarm bit (SSI option), warning bit and alarm bit (BiSS)
Status LED	Green = OK.; red = alarm	
Connection	Cable axial or radial Conin axial or radial M12, 8 pole	Cable radial Cable with Conin-Coupling
Page	113	151

Motor Feedback Systems - Comcoders for AC Synchronous & BLDC Motors



Type	M15	M21
Special features	<ul style="list-style-type: none"> ■ through hollow shaft, diameter 3.18 ... 10 mm ■ output signals: A, B, N as incremental signals as well as 4, 6 or 8 pole commutation signals ■ external diameter 40 mm (1.5") ■ mounting depth only 28 mm (1.1") ■ max. speed up to 12 000 min⁻¹ ■ operating temperature up to 120°C 	<ul style="list-style-type: none"> ■ through hollow shaft, diameter 6 ... 12.7 mm ■ output signals: A, B, N as incremental signals as well as 4, 6, 8, 10, 12 or 16 pole commutation signals ■ external diameter 53 mm (2.1") ■ mounting depth only 20 mm (0.8") ■ max. speed up to 12 000 min⁻¹ ■ operating temperature up to 120°C
Number of pulses	200 ... 1 024	500 ... 2 048
Commutation	4, 6 or 8 pole	4, 6, 8, 10, 12 or 16 pole
Technical Data - mechanical		
Shaft diameter	Hollow shaft 3.18 ... 10 mm	Hollow shaft 6 ... 12.7 mm
Max. speed	12 000 min ⁻¹	12 000 min ⁻¹
Max. speed (continuous)		
Protection class housing/bearing	IP40/40	IP40/40 (with cover)
General design		
Operating temperature	-40 ... +120 °C	-40 ... +120 °C
Diameter	39.6 mm	53 mm
Mounting depth	27.9 mm	20.3 mm
Technical Data - electrical		
Output	NPN-O.C. / RS 422	NPN-O.C. / RS 422
Supply voltage (SELV)	DC 5 V / DC 12 V ±10%	DC 5 V / DC 2 V ±10%
Max. current w/o load	Incremental: max. 100 mA Incremental + Commutation: 120 mA	Incremental: max. 100 mA Incremental + Commutation: 175 mA
Max. pulse frequency	200 kHz	200 kHz
Max. output load	NPN-O.C. 16 mA RS 422: ±40 mA	RS 422: ±40 mA NPN-O.C. 16 mA
Max. output load commutation	NPN-O.C. 16 mA RS 422: ±40 mA	NPN-O.C. 16 mA RS 422: ±40 mA
Pulse shape	Square wave	Square wave
Phasing	90°±18° electrical	90°±18° electrical
Symmetry	180°±18° electrical	180°±18° electrical
Accuracy commutation signals	±6 arc-mins. max.	±6 arc-mins. max.
Page	191	196

Motor Feedback Systems - Comcoders for AC Synchronous & BLDC Motors



Type	F10	F15	F21
Special features	<ul style="list-style-type: none"> ■ through hollow shaft, diameter 6 mm ■ output signals: A, B, N as incremental signals as well as 6 or 10 pole commutation signals ■ resolution up to 2 048 ppr ■ frequency response to 300 kHz ■ resolver compatible mounting ■ operating temperature up to 120 °C 	<ul style="list-style-type: none"> ■ through hollow shaft, diameter 9.52 mm ■ output signals: A, B, N as incremental signals as well as 6, 8 or 10 pole commutation signals ■ resolution up to 2 048 ppr ■ frequency response to 300 kHz ■ resolver compatible mounting ■ operating temperature up to 120 °C 	<ul style="list-style-type: none"> ■ through hollow shaft, diameter 12.7 mm ■ output signals: A, B, N as incremental signals as well as 6, 8, 10, 12 or 16 pole commutation signals ■ resolution up to 2 048 ppr ■ frequency response to 300 kHz ■ resolver compatible mounting ■ operating temperature up to 120 °C
Number of pulses	1 024, 2 048	1 024, 2 048	1 024, 2 048
Commutation	6 or 10 pole	6, 8 or 10 pole	6, 8, 10, 12 or 16 pole
Technical Data - mechanical			
Shaft diameter	Hollow shaft 6 mm	Hollow shaft 9.52 mm	Hollow shaft 12.7 mm
Max. speed	12 000 min ⁻¹	12 000 min ⁻¹	12 000 min ⁻¹
Max. speed (continuous)	5 000 min ⁻¹	5 000 min ⁻¹	5 000 min ⁻¹
Protection class housing/bearing	---	---	---
General design			
Operating temperature	0° ... +120 °C	0° ... +120 °C	0° ... +120 °C
Diameter	31.7mm max.	36.8 mm max.	53 mm max.
Mounting depth	22.5 mm	22.4 mm	26 mm max.
Technical Data - electrical			
Output	RS422	RS422	RS422
Supply voltage (SELV)	DC 5 V ±10 %	DC 5 V ±10 %	DC 5 V ±10 %
Max. current w/o load	100 mA max.	100 mA max.	100 mA max.
Max. pulse frequency	300 kHz	300 kHz	300 kHz
Max. output load	RS422: ±40mA,	RS422: ±40mA,	RS422: ±40mA,
Max. output load commutation	O.C.: 8mA or RS 422: ±40mA,	O.C.: 8mA or RS 422: ±40mA,	O.C.: 8mA or RS422: ±40mA,
Pulse shape	Square wave	Square wave	Square wave
Accuracy incremental signals	±2.5 arc-mins.	±2.5 arc-mins.	±2.5 arc-mins.
Accuracy commutation signals	±6 arc-mins. max.	±6 arc-mins. max.	±6 arc-mins. max.
Page	201	205	209

Motor Feedback Systems - Comcoders for AC Synchronous & BLDC Motors

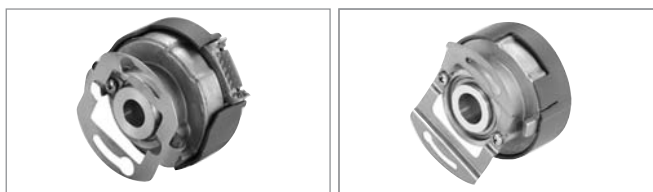

Type	F14	F18
Special features	<ul style="list-style-type: none"> ■ through hollow shaft, diameter 6 ... 8mm ■ Phased Array Technology ■ resolution up to 5 000 ppr ■ with 4, 6, 8 and 10 pole commutation signals ■ frequency response to 500 kHz ■ stator coupling ■ resolver compatible mounting (optional) ■ external diameter 40 mm ■ operating temperature up to +120°C 	<ul style="list-style-type: none"> ■ through hollow shaft, diameter 6 ... 12.7 mm ■ Phased Array Technology ■ resolution up to 10 000 ppr ■ with 4, 6, 8, 10, 12 and 16 pole commutation signals ■ frequency response to 500 kHz ■ stator coupling ■ external diameter 50 mm ■ operating temperature up to +120°C
Number of pulses	200 ... 5 000	500 ... 10 000
Commutation	4, 6, 8 or 10 pole	4, 6, 8, 10, 12 or 16 pole
Technical Data - mechanical		
Shaft diameter	Hollow shaft 6 ... 8 mm	Hollow shaft 6 ... 12.7 mm
Max. speed	12 000 min ⁻¹	12 000 min ⁻¹
Max. speed (continuous)		
Protection class housing/bearing	IP40/40 (with cover)	IP40/40 (with cover)
General design		
Operating temperature	0° ... +120 °C	0° ... +120 °C
Diameter	39.4 mm	49.7 mm
Mounting depth	34.6 mm max.	43.4 mm max.
Technical Data - electrical		
Output	O.C. or RS 422	O.C. or RS 422
Supply voltage (SELV)	DC 5 V ±10 %	DC 5 V ±10 %
Max. current w/o load	Incremental: max. 150 mA Incremental + Commutation: 175 mA	Incremental: max. 150 mA Incremental + Commutation: 175 mA
Max. pulse frequency	500 kHz	500 kHz
Max. output load	RS 422: ±40 mA NPN-O.C. 16 mA	RS 422: ±40 mA NPN-O.C. 16 mA
Max. output load commutation	NPN-O.C. 16 mA RS 422: ±40 mA	NPN-O.C. 16 mA RS 422: ±40 mA
Pulse shape	Square wave	Square wave
Accuracy incremental signals	±2.5 arc-mins.	±2.5 arc-mins.
Accuracy commutation signals	±6 arc-mins. max.	±6 arc-mins. max.
Page	213	217

Motor Feedback Systems - Comcoders for AC Synchronous & BLDC Motors



Type	RF53
Special features	<ul style="list-style-type: none"> ■ Solid shaft motor encoder for BLDC and gearless elevator traction machines ■ Incremental & Commutation ■ up to 10 000 ppr ■ up to +120 °C operating temperature ■ IP54 ■ Housing diameter 53 mm
Number of pulses	500 ... 10 000
Commutation	4, 6, 8, 10, 12,16, 20, 24 or 32 pole
Technical Data - mechanical	(preliminary)
Housing diameter	53 mm
Shaft	cone solid shaft
Flange	spring tether
Protection class housing/bearing	IP54
Shaft load axial/ radial	20 / 90 N
Axial runout of mating shaft	±1.4 mm
Radial runout of mating shaft	±0.18 mm
Max. speed	12 000 U/min (short term) 5 000 U/min (continuous)
Max. operating temperature	-20°C ... +120°C
Vibration resistance	1000 m/s ²
Shock resistance	25 m/s ²
Material shaft / housing	Stainless steel / Aluminium
Weight	200 g
Connection	Sub-D connector PCB-connector with mating connector and cable
Technical Data - electrical	(preliminary)
Output	O.C-NPN. or RS 422
Supply voltage	DC 5 ±10%
Max. current w/o load	100 mA
Code	Incremental with commutation option, optical
Tolerance Incremental signals	±2,5 arc-mins. max. (edge to edge)
Tolerance Commutation	±6 arc-mins. max.
Output frequency	max. 100 kHz
Output circuit	Differential line driver (ET7272), 40 mA max. Open Collector, max. 8 mA; Pull up mit 2,0 kOhm
Page	221

Motor Feedback Systems - Absolute Encoders for AC Synchronous & BLDC Motors



Type	AD 36	AD 58	AC 110
Technical Data - mechanical			
Housing diameter	37.5mm	58 mm	110 mm
Shaft diameter	8 mm	Cone 10 mm	up to 50 mm
Protection class shaft input	IP40	IP40	IP50 or IP64
Protection class housing	IP40	IP40	IP50 or IP64
Flange	Hollow shaft with tether	Hollow shaft with tether, tapered shaft	Hollow shaft with tether
Max. speed	Continuous 10 000 min ⁻¹ , Short term 12 000 min ⁻¹	Continuous 10 000 min ⁻¹ , Short term 12 000 min ⁻¹	IP50: 3600 min ⁻¹ IP64: 1500 min ⁻¹
Shaft load	0.01 Nm	0.01 Nm	
Torque	2.5 x 10 ⁻⁶ kgm ²	3.8 x 10 ⁻⁶ kgm ²	
Spring tether (hollow shaft) Tolerance axial / radial	± 0.5 mm/ ±0.05 mm	± 1.5 mm/ ±0.2 mm	± 0.5 mm / ± 0.05 mm
Shock resistance (IEC 68-2-27)	1 000 m/s ² (6 ms)	1 000 m/s ² (6 ms)	1000 m/ s ² (6 ms)
Vibration resistance (IEC 68-2-6)	100 m/s ² (10 ... 2 000 Hz)	100 m/s ² (10 ... 2 000 Hz)	100 m/ s ² (10 - 500 Hz)
Operating temperature	-25 ... +100 °C	-15 ... +120 °C	-20 ... +70 °C
Weight approx. ST/MT	80 g / 130 g	216 g / 310 g	1000 g
Technical Data - electrical			
Supply voltage	DC 5 V (-5 % / +10 %) or DC 7-30 V	DC 5 V, -5 % / + 10 %	DC 5 V (-5 % / +10 %) or DC 10-30 V
Max. current w/o load ST/MT	50 mA / 100 mA	50 mA / 100 mA	120 mA
Interface	BiSS or Standard SSI	BiSS or Standard SSI	
Lines/ Drives	Clock and Data / RS422	Clock and Data / RS422	Clock and Data/ RS422
Output code	Binary or Gray	Binary or Gray	Binary or Gray
Resolution singleturn	12 - 17 Bit (SSI), 12 - 19 Bit (BiSS)	13 Bit (SSI) - max. 22 Bit (BiSS)	10 - 17 Bit
Resolution multiturn	12 Bit	12 Bit	only singleturn
Optional incremental signals	Sine - Cosine 1 Vpp	Sine - Cosine 1 Vpp	Sine - Cosine 1 Vpp
Number of pulses	2048	2048	4096
3 db limiting frequency	500 kHz	500 kHz	500 kHz
Absolute accuracy	±35"	±35"	± 35"
Repeatability	±7"	±7"	± 7"
Alarm output	Alarm bit (SSI), warning bit and alarm bit (BiSS)	alarm bit (SSI), warning bit and alarm bit (BiSS)	alarm bit (SSI), warning bit and alarm bit (BiSS)
Connection	Cable PCB-Connector 12 pole	Cable PCB-Connector 12 pole	Cable radial Cable with Conin-Coupling
Page	225	228	151

Motor Feedback Systems - Sine-wave Encoders for AC Synchronous & BLDC Motors



Type	S21
Special features	<ul style="list-style-type: none"> ■ operating temperature range of -15 up to +120 °C ■ 500 kHz limiting frequency with excellent signal quality ■ excellent immunity to interference (EN 61000-4-4, Class 4) ■ signal control and system monitoring ■ high signal quality through control and error compensation
Technical Data - mechanical	
Shaft form	Cone 1/10
Shaft variations	Tapered solid shaft (Tapered hollow shaft on request)
Shaft diameter	10 mm
Absolute max. shaft load radial / axial	with tapered solid shaft: 90 N / 20 N
Balance tolerances	axial ± 0.5 mm, radial ± 0.1 mm
Max. speed	12.000 min ⁻¹
Torque	≤ 1 Ncm
Protection class (EN 60529)	IP40
General design	as per DIN EN 61010-1
Operating temperature	-15 ... +120 °C
Vibration resistance (IEC 68-2-6)	≤ 100 m/s ²
Shock resistance (IEC 68-2-27)	≤ 1000 m/s ²
Material housing	Aluminium
Connection	PCB connector + cable
Size	Ø 53.5 mm
Weight approx.	170 g
Technical Data - electrical	
Supply voltage (SELV)	DC 5 V ±10 %
Max. current w/o load	max. 120 mA
Incremental signals A, B	Sine - Cosine 1 Vpp
Number of pulses	2048
Absolute accuracy	±35"
Repeatability	±7"
Max. output frequency	500 kHz
Reference signal: R	> 0.4 V (1pulse / turn)
Commutation signal: C, D	Sine - Cosine 1 Vpp (1 period / turn)
Page	231

Motor Feedback Systems - Resolver for AC Synchronous & BLDC Motors



Type	Resolvers
Special features	<ul style="list-style-type: none"> ■ Through hollow shaft, diameter 4 up to 92 mm ■ compact design ■ easy and quick mounting procedure (standardized resolver mounting) ■ Operating temperature up to 155 °C ■ Applications, e.g. motors, machine tools, robots, automated SMD equipment, medical technology
Number of pulses	Drive or external electronics
Commutation	Drive or external electronics
Technical Data - mechanical	
Shaft diameter	Hollow shaft 4.0 .. 92.7 mm
Max. speed	20 000 min ⁻¹ (special: >30 000 min ⁻¹)
Max. speed (continuous)	
Protection class housing/bearing	---
General design	
Operating temperature	-25 ... +155 °C
Diameter	Ø 26.5 ... 139.7 mm
Mounting depth	16.5 ... 31.8 mm
Technical Data - electrical	
Output	depends on input signal
Supply voltage (SELV)	
Max. current w/o load	
Max. pulse frequency	
Max. output load	
Max. output load commutation	
Pulse shape	Sine
Tolerance	typical +/- 10°
Accuracy commutation signals	---
Page	234

for Miniature DC and Stepper Motors



- Ideal for position and speed sensing in small machines and actuators
- Low power standby mode is ideal for battery powered devices
- Operating frequency to 200 kHz
- Resolution to 512 lines/rev

GENERAL INFORMATION

The type E9 incremental optical encoder provides high performance feedback for precision motion control in a very small package. Its small envelope makes it ideal for instrument axes for position and speed control in mechanisms too small to accept standard encoders. Its high performance, advanced features, and competitive pricing make it the encoder of choice for a broad range of applications.

The E9 optical encoders utilize a patentpending ASIC that integrates all encoder electronics, including the optoelectronic sensors, which enhances reliability and accuracy.

Outputs are quadrature A and B channels with up to 512 lines per rev, an index pulse, unique up/down and rotation direction signals (version 2) or complementary CMOS-compatible (version 1). The E9 also has a low-power standby mode to conserve power in battery-operated applications.

TECHNICAL DATA mechanical

Weight	5.07 g	
Moment of inertia	0.20 gcm ²	
Hollow shaft diameter	1.5 / 2.0 / 2.5 / 3.0 / 4.0 mm 1.125" / 0.156"	
Hollow shaft tolerance	+ 0.010 / - 0.000 mm	
Mating shaft length	max. 12.16 mm min. 11.36 mm	
Mating shaft runout	± 0.0125 mm	
Mating shaft endplay	>256 ppr	±0.076mm;
	250, 256 ppr	+0.127 / -0.076mm;
	<250 ppr	+0.178/ -0.076mm
Operating temperature	-40 ... + 100 °C	
Storage temperature	-50 ... + 125 °C	
Relative humidity	90 %, non-condensing	

for Miniature DC and Stepper Motors

TECHNICAL DATA
electrical

Code	Incremental, optical
Resolution	100 up to 512 ppr
Phasing	90° ±18° electrical
Symmetry	180 ±18° electrical
Index pulse width	90° ±36° electrical
Supply voltage	DC 5 V ±10 %
Supply current	10 mA, typ.
Standby current	max. 50 µA
Output signals	min. 2.5 V high (V _{OH}) max. 0.5 V low (V _{OL})
Output current	3 mA sink/source (25°C), 2 mA (100°C)
Max. output frequency	200 kHz
Connection	10 pole header
Recommended mating connector	Thomas & Betts; part number 622-1030; on request

DIMENSIONAL DRAWINGS

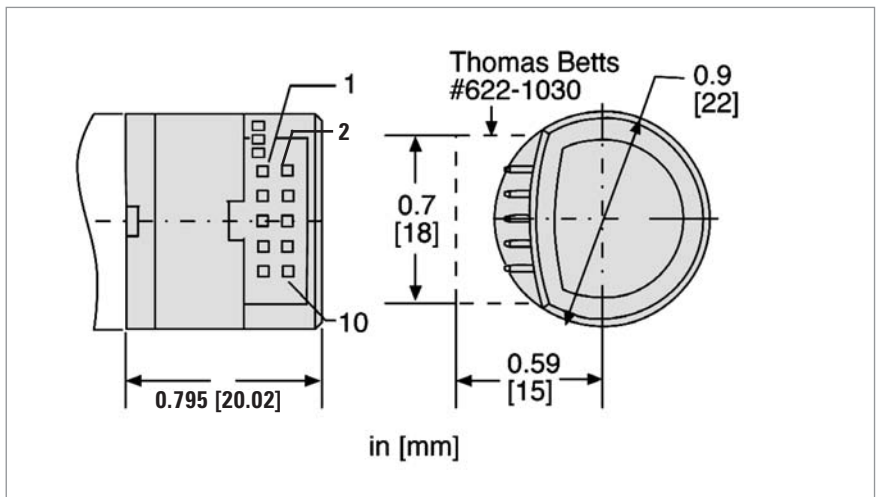

for Miniature DC and Stepper Motors

OUTPUT WAVEFORMS AND CONNECTIONS

(Direction viewing encoder cover)

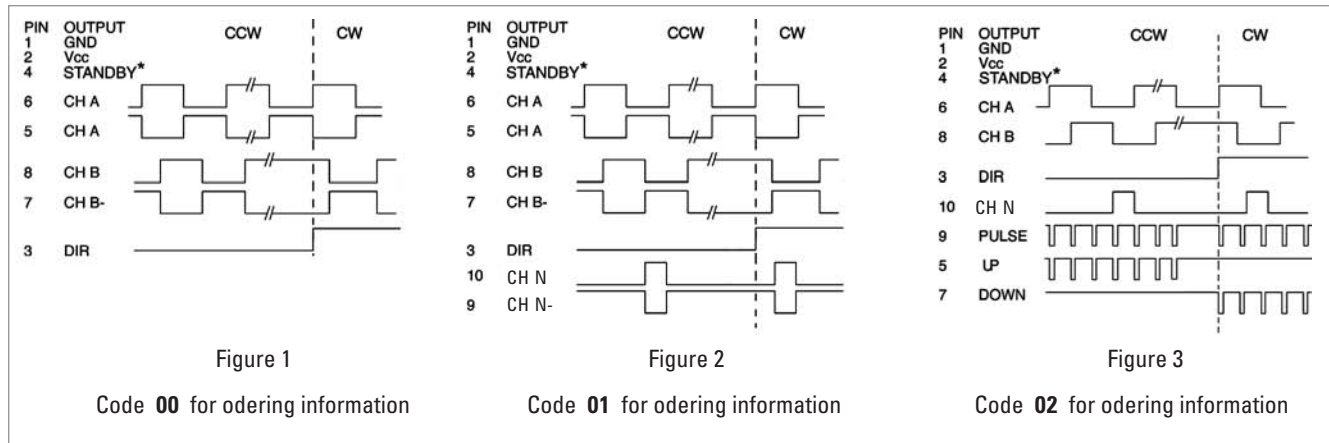

ACCESSORIES

	Ordering code
10 pole header, 30 cm ribbon cable with connector	CA 0 040 012

ORDERING INFORMATION

Type	Pulses ppr	Hub shaft	Output	Mounting
<input type="checkbox"/>	<input type="checkbox"/>	<input type="checkbox"/>	<input type="checkbox"/>	<input type="checkbox"/>
E9-	0100 0300 0144 0360 0200 0500 0256 0512	1.5 1.5 mm 2.0 2.0 mm 2.5 2.5 mm 3.0 3.0 mm 125 0.125 inch 156 0.156 inch	00 see fig. 1 01 see fig. 2 02 see fig. 3	0 No mounting base A 4 x M1.6 on 0.728" TK C 2 x #2-56 on 0.75" TK D 3 x #0-80 on 0.823" TK E 2 x #2-56 on 1.812" TK

Important:

To properly install type E9, a specialized **mounting kit** must be purchased. Only one kit is required to install any number of encoders with the same hub shaft size.

MK

E9

Hub shaft

1.5 1.5 mm

2.0 2.0 mm

2.5 2.5 mm

3.0 3.0 mm

125 0.125 inch

156 0.156 inch

Please designate hub shaft diameter.

Example: Kit for installing encoders with 3.0 mm hub shaft = MK E9 3.0

for Miniature DC and Stepper Motors



- Ideal for position and speed sensing in small machines and actuators
- 200 kHz operating frequency
- Resolution to 512 lines/rev

GENERAL INFORMATION

With a total length less than 15mm and a very low mass, the type M9 incremental optical encoder is ideally suited for use on the moving heads of pick-and-place type machines.

The M9 may be used as direct replacements for most Hewlett Packard HEDS-5XXX encoders with no changes to the motor or cable.

The M9 provides high performance feedback for precision motion control in a very small package. Its small envelope makes it ideal for instrument axes for position and speed control in mechanisms too small to accept standard encoders.

Its high performance, advanced features, and competitive pricing make it the encoder of choice for a broad range of applications.

It utilizes an ASIC that integrates all encoder electronics, including the optoelectronics sensors, which enhances reliability and accuracy.

Outputs are single-ended quadrature A and B channels with up to 512 lines per rev plus an index pulse.

TECHNICAL DATA
mechanical

Weight	4.14 g	
Moment of inertia	0.11 gcm ²	
Hollow shaft diameter	1.5 / 2.0 / 2.5 / 3.0 / 4.0 mm 1.125" / 0.156"	
Hollow shaft tolerance	+ 0.010 / - 0.000 mm	
Mating shaft length	max. 11.1 mm min. 9.75 mm	
Mating shaft runout	± 0.0125 mm	
Mating shaft endplay	256 ppr	±0.076 mm;
	250 / 256 ppr	+ 0.127 / - 0.076 mm;
	< 250 ppr	+ 0.178 / - 0.076 mm
Operating temperature	-40 ... + 100 °C	
Storage temperature	-50 ... + 125 °C	
Relative humidity	90 %, non-condensing	

for Miniature DC and Stepper Motors

TECHNICAL DATA
electrical

Code	Incremental, optical
Resolution	100 up to 512 ppr
Phasing	90° ±18° electrical
Symmetry	180 ±18° electrical
Index pulse width	90° ±36° electrical
Supply voltage	DC 5 V ±10 %
Supply current	10 mA, typ.
Output signals	min. 2.5 V high (V _{OH}) max. 0.5 V low (V _{OL})
Output current	6 mA sink/source (25°C), 4 mA (100°C)
Max. output frequency	200 kHz
Connection	5 pole header
Recommended mating connector	AMP; part number 103675-4 (on request)

DIMENSIONAL DRAWINGS

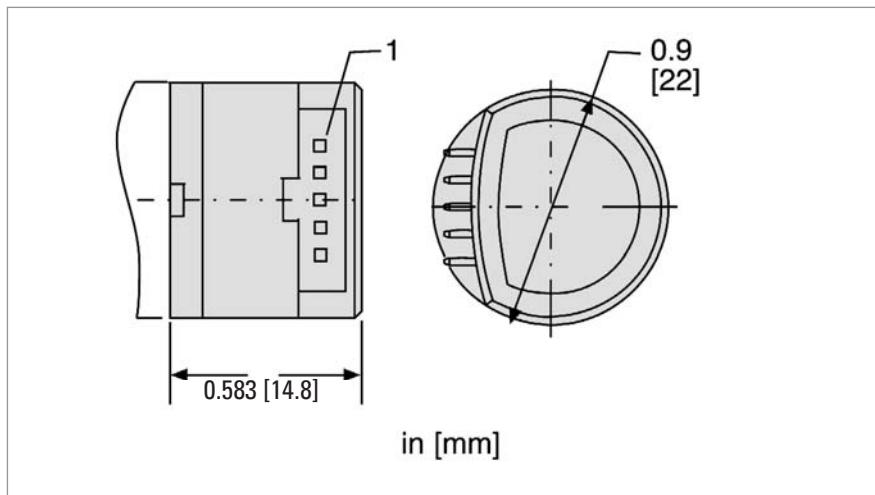

OUTPUT WAVEFORMS
AND CONNECTIONS
(Direction CCW
viewing encoder cover)

PIN	FUNCTION	CABLE WIRE
1	GND	BLACK
2	CH N	BLUE
3	CH A	WHITE
4	+U _B	RED
5	CH B	BROWN

Motor Feedback Systems Type M 9

for Miniature DC and Stepper Motors

ACCESSORIES

	Ordering code
5 pole header, 30 cm ribbon cable with connector	CA 0 050 012

ORDERING INFORMATION

Type	Pulses ppr / poles	Mounting	Hub shaft	Output
<input type="checkbox"/>	<input type="checkbox"/>	<input type="checkbox"/>	<input type="checkbox"/>	<input type="checkbox"/>
M9-	0100 / 0 0144 / 0 0200 / 0 0256 / 0 0300 / 0 0360 / 0 0500 / 0 0512 / 0	0 No mounting base A 4 x M1.6 on 18.5mm TK C 2 x #2-56 on 19.05 mm TK D 3 x #0-80 on 20.9 mm TK E 2 x #2-56 on 46.02 mm TK	1.5 1.5 mm 2.0 2.0 mm 2.5 2.5 mm 3.0 3.0 mm 4.0 4.0 mm 125 0.125 inch 156 0.156 inch	1 5 pin header 2 flying leads

Important:

To properly install type M9, a specialized **mounting kit** must be purchased. Only one kit is required to install any number of encoders with the same hub shaft size.

MK

M9

Please designate hub shaft diameter.

Hub shaft

1.5 1.5 mm

2.0 2.0 mm

2.5 2.5 mm

3.0 3.0 mm

125 0.125 inch

156 0.156 inch

Example: Kit for installing encoders with 3.0 mm hub shaft = MK M9 3.0

for Miniature DC and Stepper Motors



- Ideal economical feedback device for servo and step motors
- Short axial length and compact 1.5 inch diameter
- Easy "snap-on" installation
- High resolution to 1024 lines/rev and 200 kHz bandwidth
- Drop-in replacement for HP 5540
- CE-qualified

GENERAL INFORMATION

The type M14 of incremental optical encoders provides high performance feedback for precision motion control in a small, low cost package.

Its high performance, advanced features, and competitive pricing make it the encoder of choice for a broad range of applications.

The M14 optical encoder utilizes a patentpending ASIC that integrates all encoder electronics, including the optoelectronic sensors, which enhances reliability and accuracy.

Quadrature A and B channels with up to 1024 lines per revolution and reference pulse are output as single-ended TTL/CMOS compatible signals.

The M 14 can be used as drop-in replacement for HP 5540.

TECHNICAL DATA
mechanical

Weight	6.2 g	
Moment of inertia	0.13 gcm ²	
Hollow shaft diameter	3.0 bis 8.0 mm	
Hollow shaft tolerance	+0.010 mm / -0.000 mm	
Mating shaft length	max. 13.3 mm; min. 11.07 mm	
Mating shaft runout	± 0.0125 mm	
Mating shaft endplay	>512 ppr	±0.076 mm;
	500 / 512 ppr	±0.127 / - 0.076 mm;
	< 500 ppr	+ 0.178 / - 0.076 mm
Operating temperature	-40 °C ... 100 °C	
Storage temperature	-50 °C ... 125 °C	
Relative humidity	90 % non-condensing	

Motor Feedback Systems Type M 14

for Miniature DC and Stepper Motors

TECHNICAL DATA electrical

Code	Incremental, optical
Resolution	200 up to 1 024 ppr
Phasing	90° ±18° electrical
Symmetry	180 ±18° electrical
Index pulse width	90° ±36° electrical
Supply voltage	DC 5 V ±10 %
Supply current	10 mA, typ.
Output signals	min. DC 2.5 V high (V _{OH}) max. DC 0.5 V low (V _{OL})
Output current	6mA sink/source (25°C) 4 mA (100°C)
Max. output frequency	200 kHz
Connection	5 pole header
Recommended mating connector	AMP, part number. 103969-4 (on request)

DIMENSIONAL DRAWING

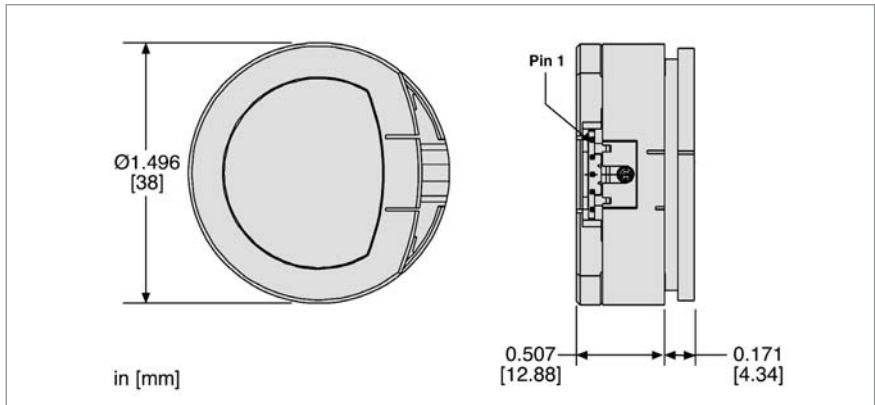

OUTPUT WAVEFORMS & CONNECTIONS (Direction viewing encoder cover)

PIN	FUNCTION		CABLE WIRE
5	GND		BLACK
4	CH N		BLUE
3	CH A		WHITE
2	+U _B		RED
1	CH B		BROWN

for Miniature DC and Stepper Motors

ACCESSORIES

	Ordering code
5 pole header, 30 cm ribbon cable with connector	CA 0 060 012

ORDERING INFORMATION

Type	Pulses ppr / poles	Mounting	Hub shaft
<input type="checkbox"/>	<input type="checkbox"/>	<input type="checkbox"/>	<input type="checkbox"/>
M14-	0 200 / 0 0 400 / 0 0 500 / 0 0 512 / 0 1 000 / 0 1 024 / 0	0 No mounting base A 2 x #2-56 on 1.28" TK B 3 x #0-80 on 0.823" TK C 2 x #2-56 on 0.75" TK	3.0 3 mm 187 0.1873 inch 4.0 4 mm 249 0.2498 inch 5.0 5 mm 250 0.2501 inch 6.0 6 mm 312 0.3123 inch 8.0 8 mm 374 0.3748 inch 125 0.1248 inch 375 0.3750 inch

Important:

To properly install type M14, a specialized **mounting kit** must be purchased. Only one kit is required to install any number of encoders with the same hub shaft size.

<div style="border: 1px solid black; padding: 2px; display: inline-block;">MK</div> <div style="border: 1px solid black; padding: 2px; display: inline-block; margin-left: 5px;">M 14</div> <div style="border: 1px solid black; width: 40px; height: 15px; display: inline-block; margin-left: 5px;"></div>	Hub shaft	
	3.0 3 mm 187 0.1873 inch 4.0 4 mm 249 0.2498 inch 5.0 5 mm 250 0.2501 inch 6.0 6 mm 312 0.3123 inch 8.0 8 mm 374 0.3748 inch 125 0.1248 inch 375 0.3750 inch	
Please designate hub shaft diameter.		

Example: Kit for installing encoders with 0.1248" mm hub shaft = MK M14 125

Motor Feedback Systems - Hollow shaft Encoders for Asynchronous & DC Motors Incremental

OVERVIEW

Our hollow shaft encoder industry types are particularly suitable as a motor feedback product for asynchronous- and DC motors. Due to the partially higher requirements on the operating temperature, there are specially developed high temperature versions (-TD) available, among certain types.



HOLLOW SHAFT ENCODER RI36-H

- Miniature industry encoder for high numbers of pulses (5 .. 3600)
- Hollow shaft (up to 10mm)
- Short overall length
- Easy and quick mounting procedure

There are two different spring tethers available.

Detailed description: Page 62



HOLLOW SHAFT ENCODERS RI58-D, TD, -G, TG

- Flexible hollow shaft design up to diameter 14 mm (-D,TD), 15mm hollow shaft (-G,TG)
- Short overall length
- Easy installation by means of clamping ring or blind shaft
- Operating temperature up to 100°C (RI58 TD and TG)
- High number of pulses (5 .. 5000) with -D
- Limited number of pulses (4 .. 2500) with TD and (50 .. 2500) with TG

The RI58 hollow shaft family offers a broad spectrum of mounting possibilities and is the right choice for all drive systems because of its high temperature option.

Detailed description of RI58-D, TD: Page 68

Detailed information of RI58-G, TG on request



HOLLOW SHAFT ENCODER RI76TD

- Through hollow shaft with up to diameter 42 mm
- Short overall length with an outside diameter of only 76 mm
- Easy installation by means of clamping ring
- Operating temperature up to 100 °C

Different Mounting options are available.

Detailed description: Page 72



HOLLOW SHAFT ENCODER RI80-E

- Incremental Output
- 30...45 mm hollow shaft
- Rugged mechanical design
- Unbreakable disc
- Integrated diagnostic system
- Wide voltage range DC 5 ... 30 V

The RI80-E is the first encoder using the latest Hengstler OptoAsic technology.

Detailed description: Page 78

Motor Feedback Systems - Hollow shaft Encoders for Asynchronous & DC Motors **Absolute**

OVERVIEW

Our absolute hollow shaft encoders of the Acuro family are particularly suitable as a motor feedback product for asynchronous- and DC motors, with special requirements concerning dynamics and absolute positioning. Besides the standard interfaces BiSS and SSI they offer additional Sin Cos of output signals.



ABSOLUTE HOLLOW SHAFT ENCODER AC58

- Absolute standard industry encoder with high resolution
- Hollow shaft (up to 12 mm)
- Short overall length
- Easy and quick mounting procedure

The AC58 offers all characteristics of the Acuro family in one universal design.

Detailed description: Page 113



ABSOLUTE HOLLOW SHAFT ENCODER AC110

- Robust absolute industry encoder with high resolution
- Hollow shaft (up to 50mm)
- Short overall length
- Easy and quick mounting procedure

The AC110 offers all characteristics of the Acuro family for applications with large shaft diameters (elevators, direct drives).

Detailed description: Page 151

Motor Feedback Systems Type M 15

for AC Synchronous & BLDC Motors



- Incremental + commutation
- Practically no speed limitation, since up to 12000 RPM
- Very good dynamic behaviour through low moment of inertia of rotor and its minimal influence on the motor
- Very good drive stiffness since no coupling is used
- Compact size
- Excellent price-performance ratio
- Increased temperature range, -40 to +120°C
- Incomparable shaft play tolerances (to 0.7 mm axial)
- Better frequency, 200 KHz
- Flexibility, since the user can integrate in all actual motor sizes
- Simple mounting and adjustment since encoders come aligned and gapped

NUMBER OF PULSES

200, 400, 500, 1000, 1024;
optional 4, 6 or 8 pole commutation signals

TECHNICAL DATA mechanical

Weight	23 g without cover, 28 g with cover
Dimensions	
Outside diameter	39.6 mm with cover, 37.1 mm without cover
Depth	27.9 mm with cover ¹ , 24.1 mm without cover
Hub shaft diameters	6 mm / 8 mm / 10 mm / 3.18 mm (1/8") / 4.76 mm (3/16") / 6.35 mm (1/4") / 9.52 mm (3/8")
Hollow shaft tolerance	+0.026 mm ... -0.000 mm
Mating shaft length	min. 12 mm max. 22 mm with closed cover
Shaft misalignment	axial endplay ² : +0.38 mm ... -0.38 mm radial runout: 0.05 mm (incl. angular misalignment)
Alignment of encoder channels to motor windings	coarse alignment: index mark on hub fine alignment: ±15° mechanical alignment range
Max. speed	12000 min ⁻¹
Moment of inertia	4.7 gcm ²
Protection class (EN 60529)	IP40 ⁴ (version cable) IP30 ⁴ (version dual row connector)
Operating temperature	-40 ... +120 °C
Storage temperature	-40 ... +85 °C
Vibration resistance (IEC 68-2-6)	25 m/s ² (5 ... 2000 Hz)
Shock resistance (IEC 68-2-27)	500 m/s ² (11 ms)
Connection	shielded cable radial or dual row connector ³
Housing	glassfibre reinforced plastic

¹ for radial cable connection

² + means away from mounting face

³ 10 pins for version incremental only, 14 pins for version incremental+commutation

⁴ mounted and with cover

for AC Synchronous & BLDC Motors

TECHNICAL DATA
electrical

General design	as per DIN EN 61010-Teil 1, protection class III, contamination level 2, over voltage class II	
Supply voltage	DC 5 or 12 V ±10 % (SELV)	
Max. current w/o load	Incremental: max. 100 mA Incremental + Commutation: max. 120 mA	
Recommended external fuse	T 0.125 A	
Output circuit	NPN-Open Collector, max. 16 mA, Pull-up 2.0 KΩ RS 422, max. 40 mA	
Output signals		
Incremental	NPN-O.C: A, B, N	RS 422: A, B, N, \bar{A} , \bar{B} , \bar{N}
Commutation (optional):	NPN-O.C: U, V, W	RS 422: U, V, W, \bar{U} , \bar{V} , \bar{W}
Accuracy		
Incremental signals	max. ±5 arc-mins. (edge to any edge)	
Commutation signals	max. ±6 arc-mins.	
Phasing		
Incremental signals (A to B)	90° ±18° electrical	
Commutation signals	8 pole: 30°, 6 pole: 40°, 4 pole: 60° mechanical	
Index to U	±1° mech. index pulse center to U channel edge	
Pulse width		
Incremental signals	180° ±18° electrical	
Commutation signals	8 pole: 45°, 6 pole: 60°, 4 pole: 90° mechanical	
Max. output frequency	200 kHz	
Noise immunity ¹	as per EN 61000-4- 2, 3, 4, 8 EN 61000-4- 6 with 3 V/m	
Noise emission ¹	as per EN 50081-2 (1993 edition)	

¹ EMC values are only valid for version with screened cable (connection code A ... H)

Motor Feedback Systems Type M 15

for AC Synchronous & BLDC Motors

DIMENSIONAL DRAWINGS

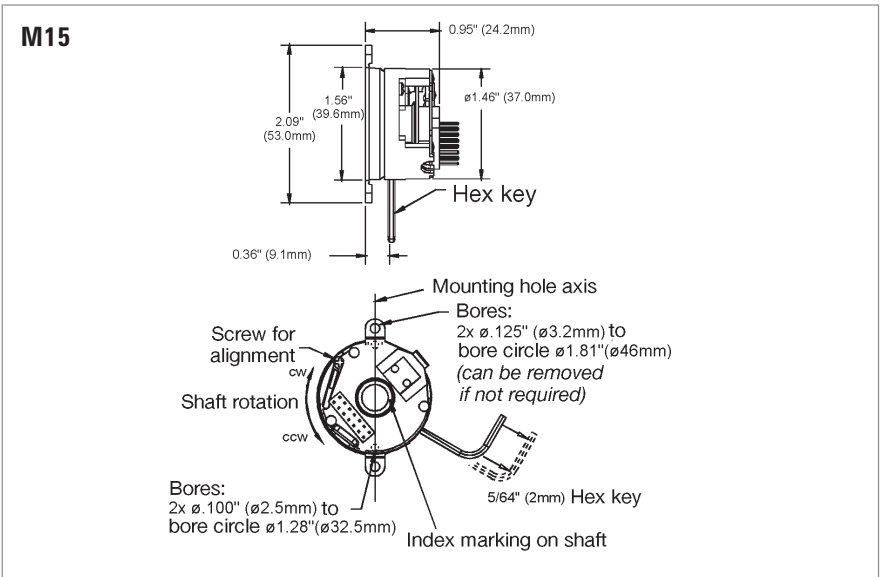

PULSE DIAGRAM

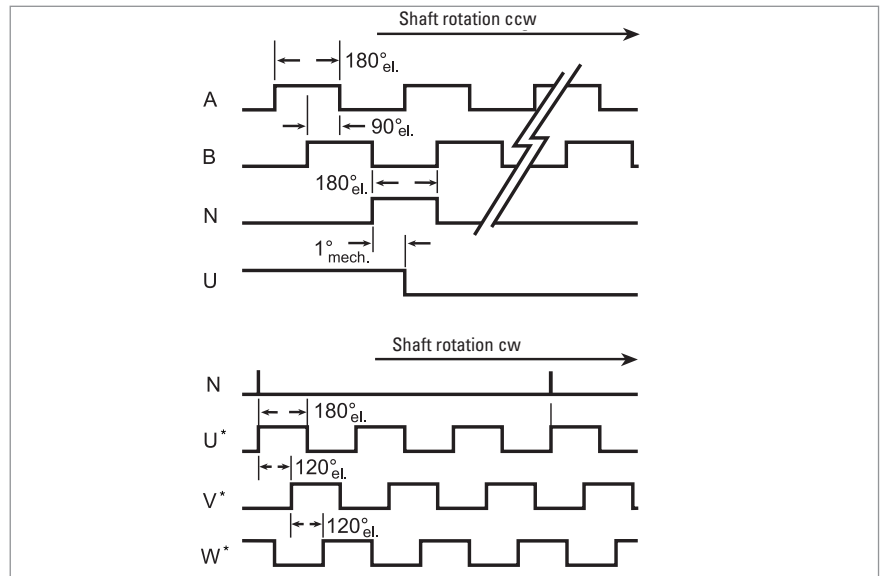

* Example with 6 pole commutation

for AC Synchronous & BLDC Motors

CONNECTION DIAGRAM CABLE

Function	Colour for version incremental only, Code Electrical = 0, 1, 3	Colour for version incremental + commutation, Code Electrical = 6, 7, 9
$V_{CC\ com}^1$		red/white ³
$V_{CC\ inc}^1$	red	red
GND inc	black	black
GND com		black/white ³
\bar{A}^2	red/black	blue/black
A	green	blue
\bar{B}^2	white/black	green/black
B	orange	green
\bar{N}^2	blue	violet/black
N	white	violet
\bar{U}^2		brown/black
U		brown
\bar{V}^2		grey/black
V		grey
\bar{W}^2		white/black
W		white

¹ $V_{CC\ com}$ resp. $V_{CC\ inc}$ = + DC 5 V or + DC 12 V (see ordering data electrical)

² only with Output_{inc/com} = RS 422

³ not connected for code 6 and 9, as here $U_{inc} = U_{com}$

CONNECTION DIAGRAM DUAL ROW CONNECTOR

Pin	10 pole only incr., NPN-O.C., Code Electr. = 0, 1	10 pole only incr., RS422, Code Electr. = 3	14 pole incr. + commutation, Code Electr. = 6, 7, 9
1	A		V_{CC}
2	V_{CC}	V_{CC}	U
3	GND	GND	\bar{U}
4			V
5		\bar{A}	\bar{V}
6		A	W
7		\bar{B}	\bar{W}
8	B	B	\bar{A}
9		\bar{N}	A
10	N	N	B
11			\bar{B}
12			N
13			GND
14			\bar{N}

Pin Numbering:

For dual row connector with ribbon cable:
The cable side marked red designates pin 1

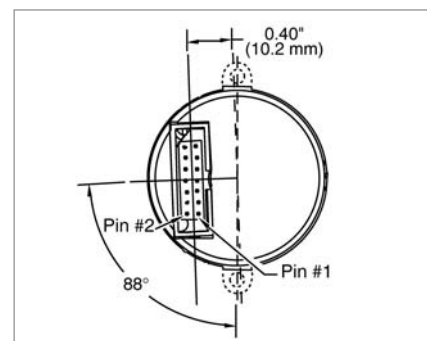
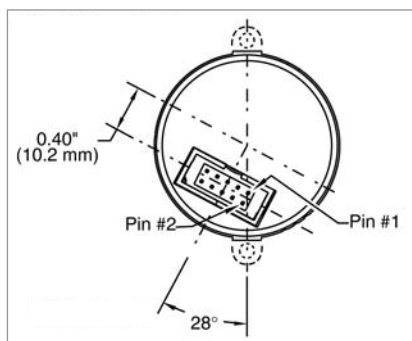

Motor Feedback Systems Type M 15

for AC Synchronous & BLDC Motors

ORDERING INFORMATION

Type	Pulses ppr incremental ²	Poles commutation ²	Housing	Electrical ¹	Hub diameter ²	Connection
□	□ /	□ -	□	□	□	□
M15-	0200 0400 0500 1000 1024	0 without 4 4 pole 6 6 pole 8 8 pole	0 without cover 1 closed cover for blind shaft 2 cover with bore for through shaft	incremental only without commutation 0 $U_{inc}=DC\ 5\ V$; output _{inc} =NPN-O.C. 1 $U_{inc}=DC\ 12\ V$; output _{inc} =NPN-O.C. 3 $U_{inc}=DC\ 5\ V$; output _{inc} =RS 422 incremental plus commutation signals 6 $U_{inc}=DC\ 5\ V$; output _{inc} =RS 422, $U_{com}=DC\ 5\ V$; output _{com} =NPN-O.C. 7 $U_{inc}=DC\ 5\ V$; output _{inc} =RS 422, $U_{com}=DC\ 12\ V$; output _{com} =NPN-O.C. 9 $U_{inc}=DC\ 5\ V$; output _{inc} =RS 422, $U_{com}=DC\ 5\ V$; output _{com} =RS 422	0 6.35 mm ($1/4''$) 1 9.52 mm ($3/8''$) 4 6 mm 5 8 mm 6 10 mm 8 4.76 mm ($3/16''$) 9 3.18 mm ($1/8''$)	0 dual row connector 1...8 dual row connector with mating ribbon cable 1=30 cm, 2=60 cm, ... A...H screened cable radial, A=30 cm, B=60 cm, ...
¹ U_{inc} : Supply voltage incremental, U_{com} : Supply voltage commutation (only if commutation selected) ² allowed combinations see available combinations (pulses/poles)						

Available combinations (pulses/poles)

Pulses ppr	Number of poles			
	0	4	6	8
0200	X			
0400	X			
0500	X	X	X	X
1000	X	X	X	X
1024	X	X	X	X

for AC Synchronous & BLDC Motors



- Incremental + commutation
- Modular hollow shaft encoder as feedback for Brushless DC (BLDC) Servos, DC Servos and Step Motors
- Outside diameter 53 mm (2.1")
- Hub diameters 6 ... 12 mm (1/4" ... 1/2")
- Height 20 mm (0.8")
- Resolution 500 ... 2048 lines
- Standard Operating temperature -40 ... +120 °C
- Maximum speed 12000 RPM
- Easy installation and alignment

NUMBER OF PULSES

500, 1000, 1024, 2000, 2048;
optional 4, 6, 8, 10, 12 or 16 pole commutation signals

TECHNICAL DATA mechanical

Weight	28 g without cover, 43 g with cover
Dimensions	
Outside diameter	53 mm with cover, 51 mm without cover
Depth	20.3 mm with cover excluding connector 17.9 mm without cover
Hub shaft diameters	6 mm / 8 mm / 10 mm / 12 mm sowie 6.35 mm (1/4") / 9.52 mm (3/8") / 11.11 mm (7/16") / 12.7 mm (1/2")
Hollow shaft tolerance	+0.026 mm ... -0.000 mm
Shaft misalignment	axial endplay: +0.13 mm ¹ ... -0.38 mm radial runout: 0.05 mm (incl. angular misalignment)
Mating shaft length	min. 16.5 mm max. 19 mm when used with closed cover
Alignment of encoder channels to motor windings	coarse alignment: index mark on the housing and disc/hub fine alignment: ±15° mechanical alignment range
Max. speed	12000 min ⁻¹
Moment of inertia	4.7 gcm ²
Protection class (EN 60529)	IP40 ² when mounted with cover
Operating temperature	-40 ... +120 °C
Storage temperature	-40 ... +120 °C
Vibration resistance (IEC 68-2-6)	25 m/s ² (5 ... 2000 Hz)
Shock resistance (IEC 68-2-27)	500 m/s ² (11 ms)
Connection	shielded cable radial or dual row connector ³
Housing	glassfibre reinforced plastic

¹ + indicates away from mounting face (cover)

² IP50 on request

³ 10 pins for version incremental only, 14 pins for version incremental +commutation

Motor Feedback Systems Type M 21

for AC Synchronous & BLDC Motors

TECHNICAL DATA electrical

General design	as per DIN EN 61010-Teil 1, protection class III, contamination level 2, over voltage class II	
Supply voltage	DC 5 or 12 V $\pm 10\%$ (SELV)	
Max. current w/o load	Incremental: max. 100 mA; commutation: max. 75 mA	
recommended external fuse	2 x T 0.125 A	
Output circuit	NPN-Open Collector, max. 16 mA; Pull-up 2.0 K Ω RS 422, max. 40 mA	
Output signals		
Incremental	NPN-O.C: A, B, N	RS 422: A, B, N, \bar{A} , \bar{B} , \bar{N}
Commutation (optional):	NPN-O.C: U, V, W	RS 422: U, V, W, \bar{U} , \bar{V} , \bar{W}
Accuracy		
Incremental signals	max. ± 5 arc-mins. (edge to any edge)	
Commutation signals	max. ± 6 arc-mins.	
Phasing		
Incremental signals (A to B)	90° $\pm 18^\circ$ electrical	
Commutation signals	12 pole: 20°, 8 pole: 30°, 6 pole: 40°, 4 pole: 60° mechanical	
Index to U	$\pm 1^\circ$ mech. index pulse center to U channel edge	
Pulse width		
Incremental signals	180° $\pm 18^\circ$ electrical	
Commutation signals	12 pole: 30°, 8 pole: 45°, 6 pole: 60°, 4 pole: 90° mechanical	
Max. output frequency.	200 kHz	
Noise immunity ¹	as per EN 50082-2	
Noise emission ¹	as per EN 50081-2	

¹ EMC values are only valid for versions with output RS422 and screened cable

for AC Synchronous & BLDC Motors

DIMENSIONAL DRAWINGS

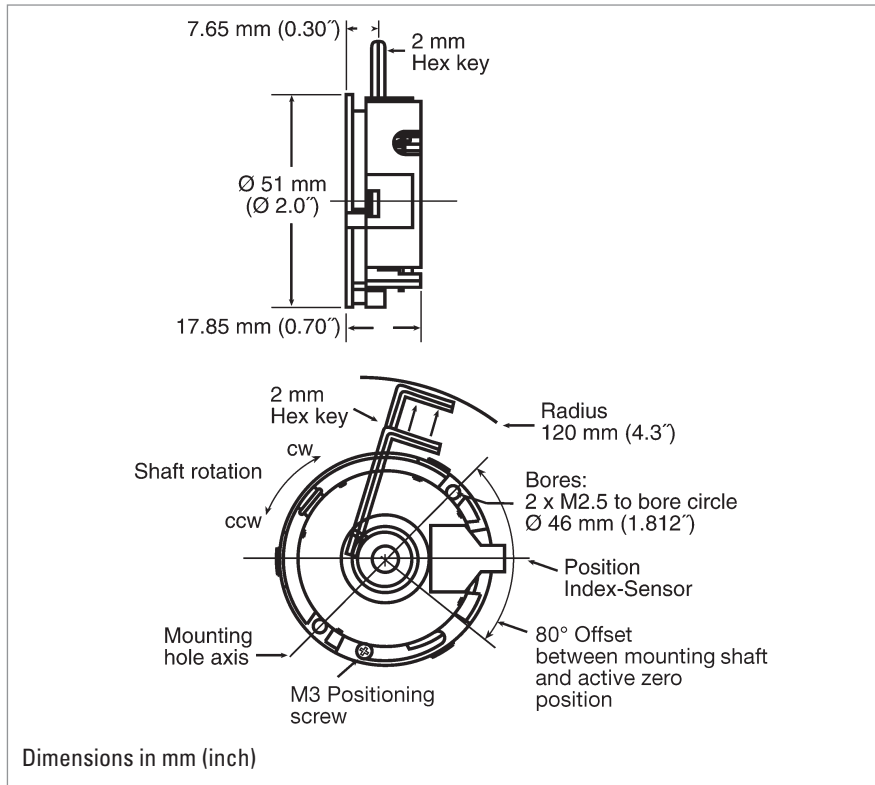

PULSE DIAGRAM

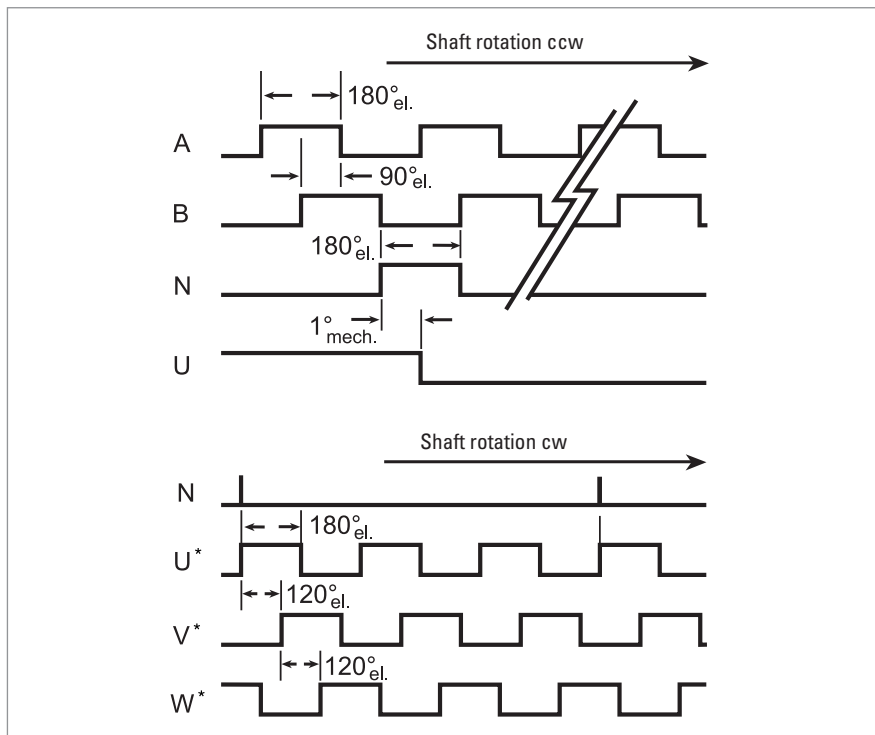

* Beispiel mit 6-poliger commutation

for AC Synchronous & BLDC Motors

CONNECTION DIAGRAM CABLE

Function	Colour for version incremental only, Code Electrical = 3	Colour for version incremental + commutation, Code Electrical = 6, 7, 9
V _{CC} com ¹		red/white ³
V _{CC} inc ¹	red	red
GND inc	black	black
GND com		black/white ³
\bar{A}	red/black	blue/black
A	green	blue
\bar{B}	white/black	green/black
B	orange	green
\bar{N}	blue	violet/black
N	white	violet
\bar{U} ²		brown/black
U		brown
\bar{V} ²		grey/black
V		grey
\bar{W} ²		white/black
W		white

¹ V_{CC} com resp. V_{CC} inc = + DC 5 V or + DC 12 V (see ordering data electrical)

² only for output_{com} = RS422

³ not connected for codes 6 and 9, since here U_{inc} = U_{com}

CONNECTION DIAGRAM CONNECTOR

Function	10 pole only incr., NPN-O.C., Code Electr. = 0, 1	10 pole only incr., RS422, Code Electr. = 3	16 pole incr. + commutation, Code Electr. = 6, 7, 9
V _{CC} com ¹			1
V _{CC} inc ¹	2	2	2
GND inc	3	3	3
GND com			4
\bar{A} ²		5	5
A	1	1	6
\bar{B} ²		7	7
B	8	8	8
\bar{N} ²		9	9
N	10	10	10
\bar{U} ²			11
U			12
\bar{V} ²			13
V			14
\bar{W} ²			15
W			16

¹ V_{CC} com resp. V_{CC} inc = + DC 5 V or + DC 12 V (see ordering data electrical)

² only for output_{inc/com} = RS422

Pin Numbering:

For dual row connector with ribbon cable:
The cable side marked red designates Pin 1

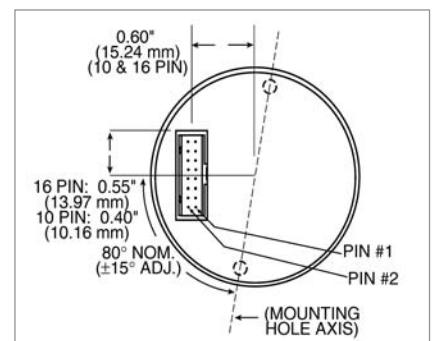

for AC Synchronous & BLDC Motors

ORDERING INFORMATION

Type	Pulses ppr incremental ⁴	Poles commutation ⁴	Housing	Electrical ¹	Hub diameter ²	Connection
<input type="checkbox"/>	<input type="checkbox"/> / <input type="checkbox"/>	<input type="checkbox"/> - <input type="checkbox"/>	<input type="checkbox"/>	<input type="checkbox"/>	<input type="checkbox"/>	<input type="checkbox"/>
M21-	0 500 0 512 1 000 1 024 2 000 2 048	0 without 4 4 pole 6 6 pole 8 8 pole A 10 pole C 12 pole X 16 pole	0 without cover 1 closed cover for blind shaft 2 cover with bore for through shaft	incremental only without commutation 0 $U_{inc}=DC\ 5\ V;$ output _{inc} =NPN-O.C. 1 $U_{inc}=DC\ 12\ V;$ output _{inc} =NPN-O.C. 3 $U_{inc}=DC\ 5\ V;$ output _{inc} =RS 422 incremental plus commutation signals 6 $U_{inc}=DC\ 5\ V;$ output _{inc} =RS 422, $U_{com}=DC\ 5\ V;$ output _{com} =NPN-O.C. 7 $U_{inc}=DC\ 5\ V;$ output _{inc} =RS 422, $U_{com}=DC\ 12\ V;$ output _{com} =NPN-O.C. 9 $U_{inc}=DC\ 5\ V;$ output _{inc} =RS 422, $U_{com}=DC\ 5\ V;$ output _{com} =RS 422	A 6.35 mm ($\frac{1}{4}''$) B 9.52 mm ($\frac{3}{8}''$) C 11.11 mm ($\frac{7}{16}''$) D 12.7 mm ($\frac{1}{2}''$) E 6 mm F 8 mm G 10 mm H 12 mm	0 dual row connector 1...8 dual row connector with mating ribbon cable 1=30 cm, 2=60 cm, ... A...H screened cable ³ radial, A=30 cm, B=60 cm, ...

¹ U_{inc} : Supply voltage incremental,
 U_{com} : Supply voltage commutation (only if commutation is selected)
² Exposed hub clamp screw
³ only possible with output = RS 422 (Code for Electrical ≥ 3)
⁴ allowed combinations see available combinations (pulses/poles)

Available combinations (pulses/poles)

Pulses ppr	Number of poles						
	0	4	6	8	10 (=A)	12 (=C)	16 (=X)
0500	X	X	X	X		X	
0512	X			X			
1000	X	X	X	X		X	
1024	X	X	X	X		X	
2000	X	X	X	X		X	
2048	X	X	X	X	X	X	X

for AC Synchronous & BLDC Motors

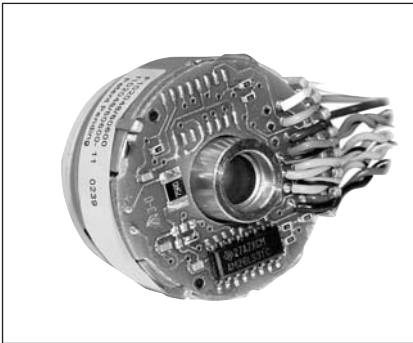

- Compact hollowshaft motor encoder, ideal for BLDC, DC-Servo and Stepper feedback
- Resolver compatible mounting
- Resolution up to 2048 ppr
- Operating temperature up to 120 °C
- Frequency response to 300 kHz
- Mounting depth 22.4 mm

GENERAL INFORMATION

The type F10 encoder provides high performance, cost effective feedback for stepper and servo motor applications. The F10 offers compact package dimensions and flying leads for a low-profile installation. A size 10 servo ring allows easy mounting and replacement of pancake resolvers with high tolerance to motor shaft movement and 360 degrees of adjustment to align the signal outputs to the shaft position.

NUMBER OF PULSES

1024, 2048;
optional additional 6 or 10 pole commutation signals

TECHNICAL DATA
mechanical

Weight approx.	45 g
Dimensions	Outside diameter: 31.7 mm max.; Height: 24.1 mm max.
Material	Housing: cast-aluminium; Servo ring: aluminium; Hub: brass; Disk: 0.76 mm thick glass
Moment of inertia	1.6 gcm ²
Hollow shaft diameter	6 mm
Hollow shaft balance	+0.001"/-0.000" (+0.025 mm/-0.000 mm)
Radial runout of mating shaft	±0.05 mm max. (includes shaft perpendicularity to mounting surface)
Axial endplay of mating shaft	±0.25 mm max.
Mounting	1.045" (26.54 mm) flexible servo ring (size 10 pancake resolver equivalent)
Acceleration	100 000 rad/s ² max.
Max. speed	5 000 min ⁻¹ continuous; 12 000 min ⁻¹ peak
Bearing life	[(3.6 x 10 ⁹) / RPM] hours; e.g. 605 000 hours at 6 000 RPM
Operating temperature	0° ... +120 °C
Storage temperature	0° ... +120 °C
Shock resistance	50 g for 6 ms duration
Vibration resistance	2.5 g at 5 to 2 000 Hz
Relative humidity	90 % non-condensing

for AC Synchronous & BLDC Motors

TECHNICAL DATA electrical

Code	Incremental with commutation, optical	
Supply voltage	DC 5 V \pm 10 % DC	
Max. current w/o load	Incremental and commutation: 100 mA max.	
Output circuit		
Incremental	26LS31 differential line driver, 40 mA max.	
Commutation	Open Collector, max. 8 mA; Pull-up 2.0 K Ω or 26LS31 differential line driver, 40 mA max.	
Output signals		
Incremental	RS 422: A, B, N, \bar{A} , \bar{B} , \bar{N}	
Commutation (optional):	O.C: U, V, W	RS 422: U, V, W, \bar{U} , \bar{V} , \bar{W}
Accuracy		
Incremental signals	+/- 2.5 arc-mins. max. (edge to edge)	
Commutation signals	+/- 6 arc-mins. max.	
Phasing	A leads B by 90° and U leads V leads W by 120°	
Minimum edge separation	A to B is 45°	
Index to U channel	+/- 1° mech. index pulse center to U channel edge (see signal diagram)	
Index pulse width	90° gated A and B high	
Max. output frequency	300kHz	
Connection	Flying leads, ...	

DIMENSIONAL DRAWINGS

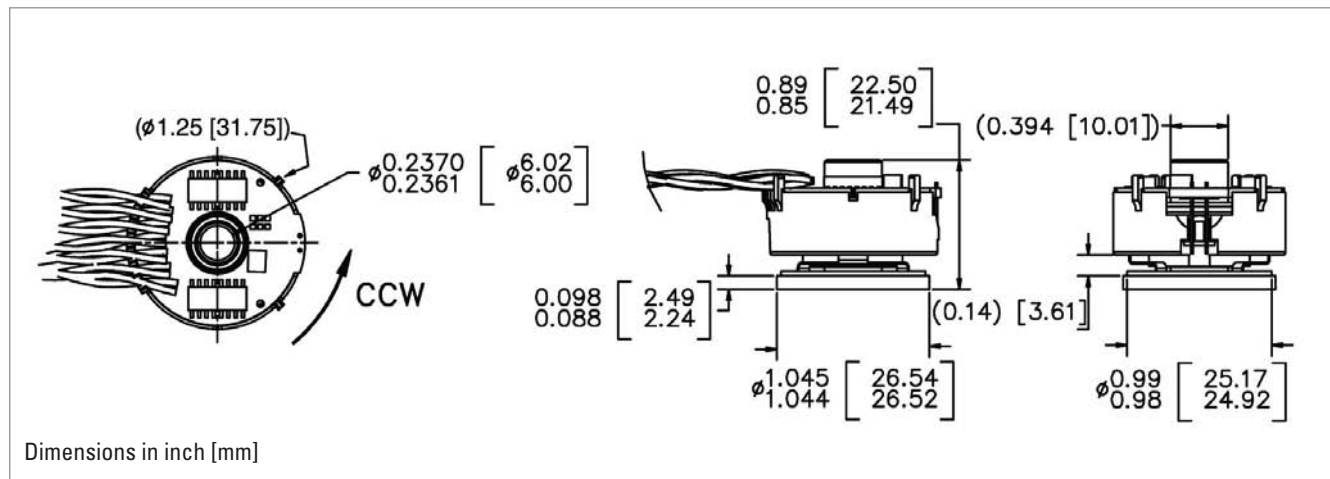

for AC Synchronous & BLDC Motors

SIGNAL DIAGRAM

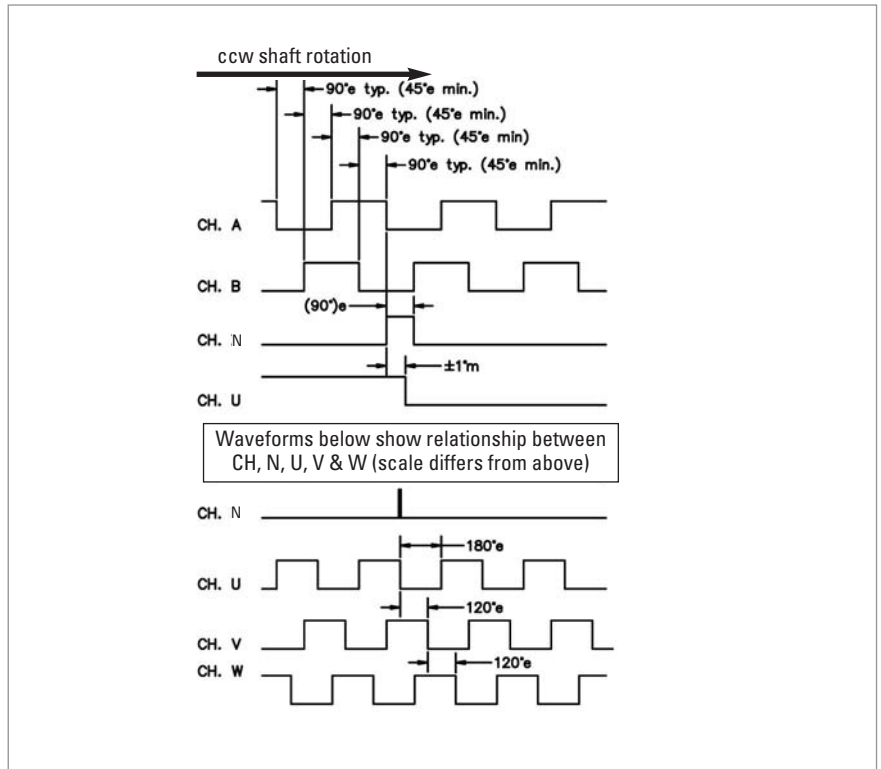

CONNECTION DIAGRAM

Function ¹	Colour
VCC	red
GND	black
\bar{A}	blue/black
A	blue
\bar{B}	green/black
B	green
\bar{N}	violet/black
N	violet
\bar{U}	brown/black
U	brown
\bar{V}	grey/black
V	grey
\bar{W}	white/black
W	white

¹ availability of function depends on version

for AC Synchronous & BLDC Motors

ORDERING INFORMATION

Type	Pulses ppr incremental ²	Poles commutation ²	Mounting	Electrical ¹	Shaft / Bore	Connection
<input type="checkbox"/>	<input type="checkbox"/> / <input type="checkbox"/>	<input type="checkbox"/> - <input type="checkbox"/>	<input type="checkbox"/>	<input type="checkbox"/>	<input type="checkbox"/>	<input type="checkbox"/>
F10-	1 024 2 048	0 without 6 6 pole C 10 pole	0 Servo ring size 10	incremental only without commutation 3 $U_{inc}=DC\ 5\ V$; output _{inc} =RS 422 incremental plus commutation signals 6 $U_{inc}=DC\ 5\ V$; output _{inc} =RS 422, $U_{com}=DC\ 5\ V$; output _{com} =NPN-O.C. 9 $U_{inc}=DC\ 5\ V$; output _{inc} =RS 422, $U_{com}=DC\ 5\ V$; output _{com} =RS 422	4 6 mm through Bore	0 16.5 cm Flying leads
¹ U_{inc} : Supply voltage incremental, U_{com} : Supply voltage commutation (only if commutation is selected) ² allowed combinations see available combinations (pulses/poles)						

Available combinations (pulses/poles)

Pulses ppr	Number of poles		
	0	6	10 (=C)
1024	X	X	X
2048	X	X	X

for AC Synchronous & BLDC Motors

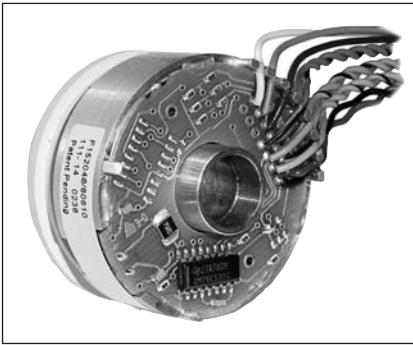

- Compact hollowshaft motor encoder, ideal for BLDC, DC-Servo and Stepper feedback
- Resolver compatible mounting
- Resolution up to 2048 ppr
- Operating temperature up to 120 °C
- Frequency response to 300 kHz
- Mounting depth 22.4 mm

GENERAL INFORMATION

The type F15 encoder provides high performance, cost effective feedback for stepper and servo motor applications. The F15 offers compact package dimensions and flying leads for a low-profile installation. A size 15 servo ring allows easy mounting and replacement of pancake resolvers with high tolerance to motor shaft movement and 360 degrees of adjustment to align the signal outputs to the shaft position.

NUMBER OF PULSES

1024, 2048;
optional additional 6, 8 or 10 pole commutation signals

TECHNICAL DATA
mechanical

Weight approx.	45 g
Dimensions	Outside diameter: 36.8 mm max.; Height: 22.1 mm max.
Material	Housing: cast-aluminium; Servo ring: aluminium; Hub: brass; Disk: 0.76 mm thick glass
Moment of inertia	2.5 gcm ²
Hollow shaft diameter	9.52 mm
Hollow shaft balance	+0.001"/-0.000" (+0.025 mm/-0.000 mm)
Radial runout of mating shaft	±0.05 mm max. (includes shaft perpendicularity to mounting surface)
Axial endplay of mating shaft	±0.25 mm max.
Mounting	1.450" (36.83 mm) flexible servo ring (size 15 pancake resolver equivalent)
Acceleration	100 000 rad/s ² max.
Max. speed	5 000 min ⁻¹ continuous; 12 000 min ⁻¹ peak
Bearing life	[(3.6 x 10 ⁹) / RPM] hours; e.g. 605 000 hours at 6 000 RPM
Operating temperature	0° ... +120 °C
Storage temperature	0° ... +120 °C
Shock resistance	50 g for 6 ms duration
Vibration resistance	2.5 g at 5 to 2 000 Hz
Relative humidity	90 % non-condensing

for AC Synchronous & BLDC Motors

TECHNICAL DATA
electrical

Code	Incremental with commutation, optical	
Supply voltage	DC 5 V ±10 % DC	
Max. current w/o load	Incremental and commutation: 100 mA max.	
Output circuit		
Incremental	26LS31 differential line driver, 40 mA max.	
Commutation	Open Collector, max. 8 mA; Pull-up 2.0 KΩ or 26LS31 differential line driver, 40 mA max.	
Output signals		
Incremental	RS 422: A, B, N, \bar{A} , \bar{B} , \bar{N}	
Commutation (optional):	O.C: U, V, W	RS 422: U, V, W, \bar{U} , \bar{V} , \bar{W}
Tolerance		
Incremental signals	+/- 2.5 arc-mins. max. (edge to any edge)	
Commutation signals	+/- 6 arc-mins. max.	
Phasing	A leads B by 90° and U leads V leads W by 120°	
Minimum edge separation	A to B is 45°	
Index to U channel	+/- 1° mech. index pulse center to U channel edge (see signal diagram)	
Index pulse width	90° gated A and B high	
Max. output frequency	300kHz, max.	
Connection	Flying leads, ...	

DIMENSIONAL DRAWINGS

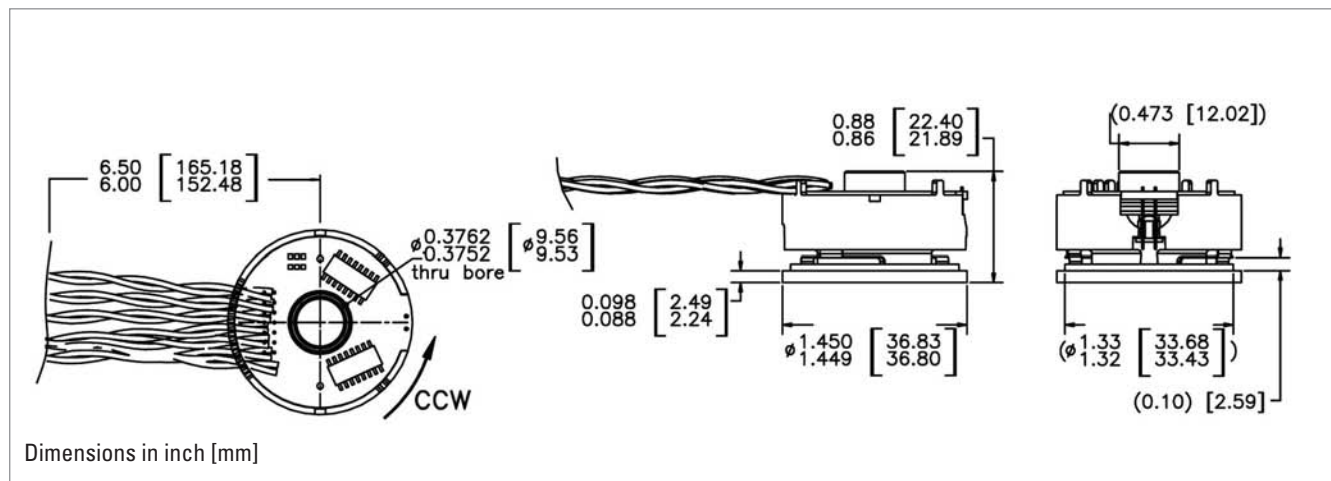

for AC Synchronous & BLDC Motors

SIGNAL DIAGRAM

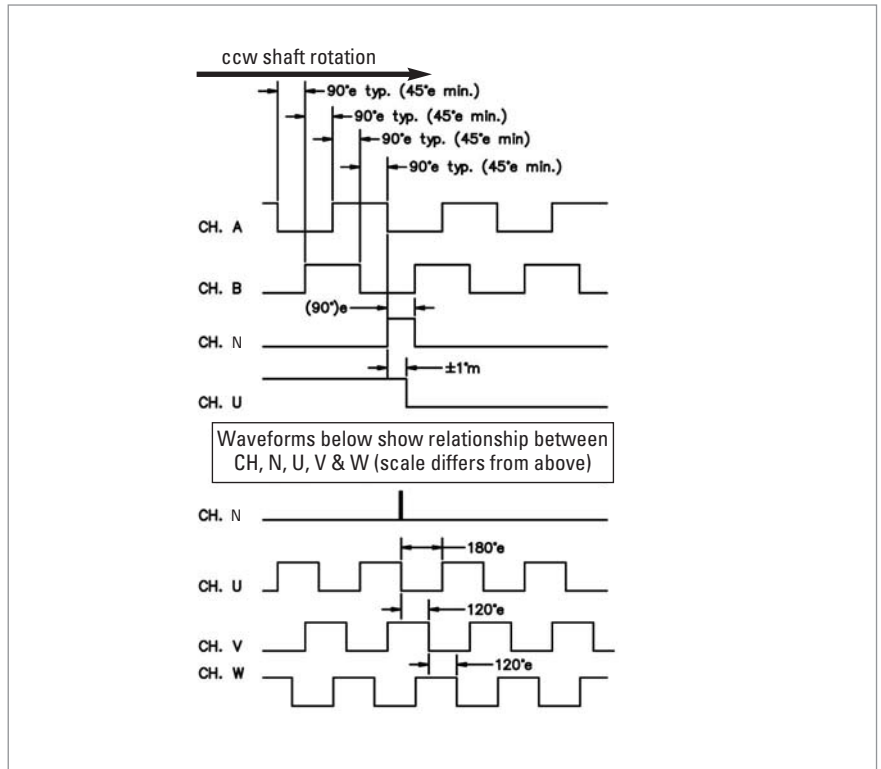

CONNECTION DIAGRAM

Function ¹	Colour
VCC	red
GND	black
\bar{A}	blue/black
A	blue
\bar{B}	green/black
B	green
\bar{N}	violet/black
N	violet
\bar{U}	brown/black
U	brown
\bar{V}	grey/black
V	grey
\bar{W}	white/black
W	white

¹ availability of function depends on version

for AC Synchronous & BLDC Motors

ORDERING INFORMATION

Type	Pulses ppr incremental ²	Poles commutation ²	Mounting	Electrical ¹	Shaft / Bore	Connection
<input type="checkbox"/>	<input type="checkbox"/> / <input type="checkbox"/>	<input type="checkbox"/> - <input type="checkbox"/>	<input type="checkbox"/>	<input type="checkbox"/>	<input type="checkbox"/>	<input type="checkbox"/>
F15-	1 1024 2 2048	0 without 6 6 pole 8 8 pole C 10 pole	0 Servo ring size 15	incremental only without commutation 3 $U_{inc}=DC\ 5\ V$; output _{inc} =RS 422 incremental plus commutation signals 6 $U_{inc}=DC\ 5\ V$; output _{inc} =RS 422, $U_{com}=DC\ 5\ V$; output _{com} =NPN-O.C. 9 $U_{inc}=DC\ 5\ V$; output _{inc} =RS 422, $U_{com}=DC\ 5\ V$; output _{com} =RS 422	1 9.52 mm through bore	0 16.5 cm Flying leads

¹ U_{inc} : Supply voltage incremental,
 U_{com} : Supply voltage commutation (only if commutation is selected)
² allowed combinations see available combinations (pulses/poles)

Available combinations (pulses/poles)

Pulses ppr	Number of poles			
	0	6	8	10 (=C)
1024	X	X	X	X
2048	X	X	X	X

for AC Synchronous & BLDC Motors



- Compact hollowshaft motor encoder, ideal for BLDC, DC-Servo and Stepper feedback
- Resolver compatible mounting
- Resolution up to 2048 ppr
- Operating temperature up to 120 °C
- Frequency response to 300 kHz
- Mounting depth 22.4 mm

GENERAL INFORMATION

The type F21 encoder provides high performance, cost effective feedback for stepper and servo motor applications. The F21 offers compact package dimensions and flying leads for a low-profile installation. A size 21 servo ring allows easy mounting and replacement of pancake resolvers with high tolerance to motor shaft movement and 360 degrees of adjustment to align the signal outputs to the shaft position.

NUMBER OF PULSES

1024, 2048;
optional additional 6, 8, 10, 12 or 16 pole commutation signals

TECHNICAL DATA
mechanical

Weight approx.	90 g
Dimensions	Outside diameter: 52.4 mm max.; Height: 25.7 mm max.
Material	Housing: cast-aluminium; Servo ring: aluminium; Hub: brass; Disk: 0.76 mm thick glass
Moment of inertia	2.5 gcm ²
Hollow shaft diameter	12.7 mm
Hollow shaft balance	+0.001"/-0.000" (+0.025 mm/-0.000 mm)
Radial runout of mating shaft	±0.05 mm max. (includes shaft perpendicularity to mounting surface)
Axial endplay of mating shaft	±0.25 mm max.
Mounting	2.062" (52.4 mm) flexible servo ring (size 21 pancake resolver equivalent)
Acceleration	100 000 rad/s ² max.
Max. speed	5 000 min ⁻¹ continuous; 12 000 min ⁻¹ peak
Bearing life	[(3.6 x 10 ⁹) / RPM] hours; e.g. 605 000 hours at 6 000 RPM
Operating temperature	0° ... +120 °C
Storage temperature	0° ... +120 °C
Shock resistance	50 g for 6 ms duration
Vibration resistance	2.5 g at 5 to 2 000 Hz
Relative humidity	90 % non-condensing

for AC Synchronous & BLDC Motors

TECHNICAL DATA
electrical

Code	Incremental with commutation, optical	
Supply voltage	DC 5 V ±10 % DC	
Max. current w/o load	Incremental and commutation: 100 mA max.	
Output circuit		
Incremental	26LS31 differential line driver, 40 mA max.	
Commutation	Open Collector, max. 8 mA; Pull-up 2.0 KΩ or 26LS31 differential line driver, 40 mA max.	
Output signals		
Incremental		RS 422: A, B, N, \bar{A} , \bar{B} , \bar{N}
Commutation (optional):	O.C: U, V, W	RS 422: U, V, W, \bar{U} , \bar{V} , \bar{W}
Accuracy		
Incremental signals	+/- 2.5 arc-mins. max. (edge to any edge)	
Commutation signals	+/- 6 arc-mins. max.	
Phasing	A leads B by 90° and U leads V leads W by 120°	
Minimum edge separation	A to B is 45°	
Index to U channel	+/- 1° mech. index pulse center to U channel edge (see signal diagram)	
Index pulse width	90° gated A and B high	
Max. output frequency	300kHz, max.	
Connection	Flying leads, ...	

DIMENSIONAL DRAWINGS

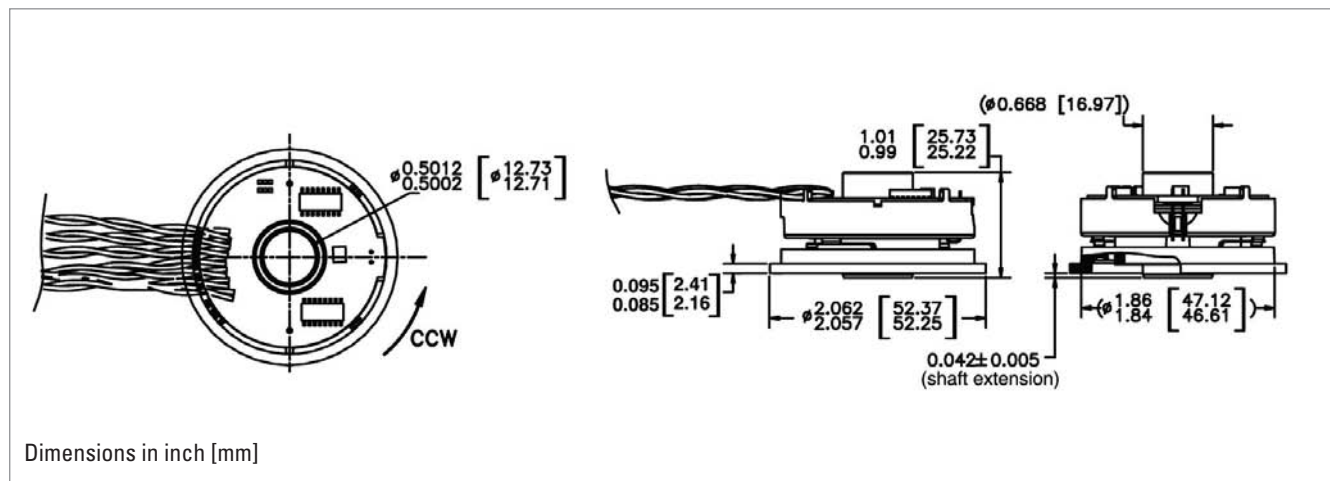

for AC Synchronous & BLDC Motors

SIGNAL DIAGRAM

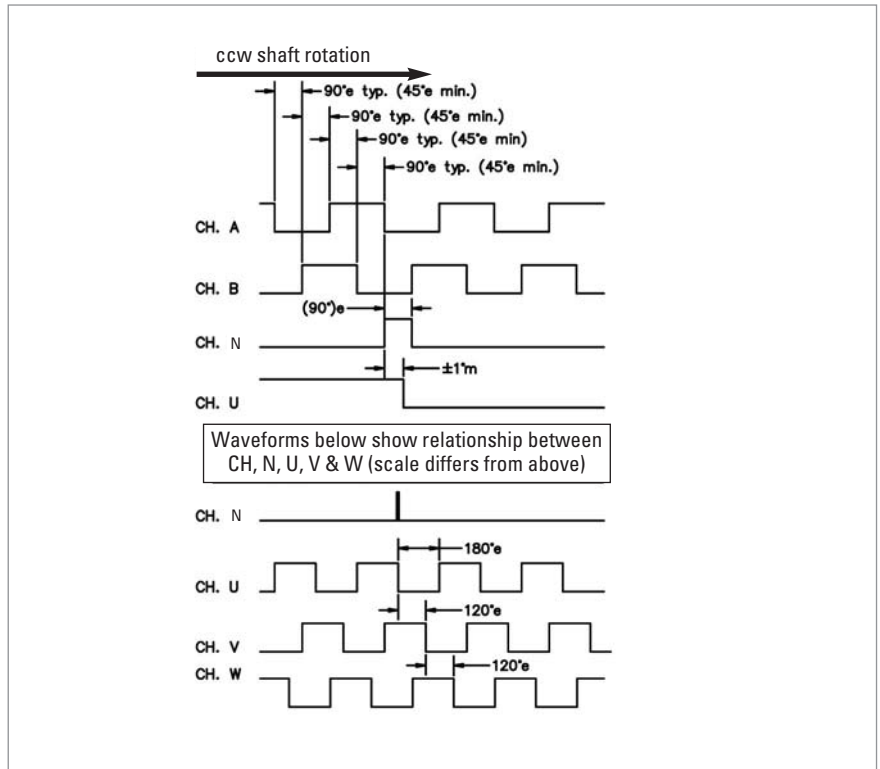

CONNECTION DIAGRAM

Function ¹	Colour
VCC	red
GND	black
\bar{A}	blue/black
A	blue
\bar{B}	green/black
B	green
\bar{N}	violet/black
N	violet
\bar{U}	brown/black
U	brown
\bar{V}	grey/black
V	grey
\bar{W}	white/black
W	white

¹ availability of function depends on version

for AC Synchronous & BLDC Motors

ORDERING INFORMATION

Type	Pulses ppr incremental ²	Poles commutation ²	Mounting	Electrical ¹	Shaft / Bore	Connection
<input type="checkbox"/>	<input type="checkbox"/> /	<input type="checkbox"/> -	<input type="checkbox"/>	<input type="checkbox"/>	<input type="checkbox"/>	<input type="checkbox"/>
F21-	1 024 2 048	0 without 6 6 pole 8 8 pole C 10 pole E 12 pole I 16 pole	0 Servo ring size 21	incremental only without commutation 3 $U_{inc}=DC\ 5\ V$; output _{inc} =RS 422 incremental plus commutation signals 6 $U_{inc}=DC\ 5\ V$; output _{inc} =RS 422, $U_{com}=DC\ 5\ V$; output _{com} =NPN-O.C. 9 $U_{inc}=DC\ 5\ V$; output _{inc} =RS 422, $U_{com}=DC\ 5\ V$; output _{com} =RS 422	3 12.7 mm through bore	0 16.5 cm Flying leads
¹ U_{inc} : Supply voltage incremental, U_{com} : Supply voltage commutation (only if commutation is selected) ² allowed combinations see available combinations (pulses/poles)						

Available combinations (pulses/poles)

Pulses ppr	Number of poles					
	0	6	8	10 (=C)	12 (=E)	16 (=I)
1024	X	X	X	X	X	X
2048	X	X	X	X	X	X

for AC Synchronous & BLDC Motors



- Compact hollowshaft motor encoder, ideal for BLDC, DC-Servo and Stepper feedback
- Incremental & commutation
- Phased Array Technology
- Up to 5000 ppr
- Frequency response to 500 kHz
- Operating temperature up to 120°C
- Trough hollow shaft up to diameter 8 mm
- Stator coupling
- External diameter 40 mm
- Cable plug-in radial/axial

GENERAL INFORMATION

The type F14 offers compact package dimensions and a pluggable pin header. A compliant tether allows easy mounting with high tolerance to motor shaft movement and 30 degrees of adjustment to align the signal outputs to the shaft position.

A superior optical configuration allows for generous internal component clearance eliminating potential damage at high ambient operating temperatures. High temperature rated grease is standard for extended bearing life. No special tools are required for installation.

The use of optically-generated signals for Brushless DC (BLDC) servo control provides higher accuracy and reliability by eliminating the hysteresis found in competitive units with hall effect sensors, ensuring maximum performance and reliability of the servo system.

NUMBER OF PULSES

200, 400, 500, 1000, 1024, 2000, 2048, 2500, 4096, 5000;
optional additional 4, 6, 8 or 10 pole commutation signals

TECHNICAL DATA
mechanical

Shaft	Through hollow shaft
Shaft diameter	6.8 mm; 1/4"
Shaft tolerance	+0.025 / -0.000 mm
Moment of inertia	5.8 gcm ²
Axial endplay of mating shaft	±1.5 mm
Radial runout of mating shaft	0.05 mm (includes shaft perpendicularity)
Max. speed	(Frequency / ppr) x 60 or 12000 min ⁻¹ , whichever is less
Bearing life	(1.4 x 10 ⁹) / RPM [hours] e.g. 230 000 hours at 6 000 RPM
Protection class	IP40 (with cover)
Operating temperature	0 ... +120 °C
Storage temperature	-40 ... +120 °C
Shock resistance	1000 m/s ² (11 ms)
Vibration resistance	25 m/s ² (5...2000 Hz)
Material housing	Aluminium

for AC Synchronous & BLDC Motors

TECHNICAL DATA electrical

Supply voltage	DC 5 V $\pm 10\%$
Max current w/o load	Max. 150 mA (incremental) Max. 175 mA (incremental +commutation)
Incremental signals	A, B
Resolution	Max. 5 000 ppr (see ordering information)
Accuracy	Incremental 2' (2 edges to any edges)
Phasing A to B	A leads B by 90° cw (view on mounting shaft)
Phasing tolerance A to B	$\pm 45^\circ$
Max. output frequency	250 kHz up to 1 024 ppr 500 kHz > 1 024 ppr
Signal level	TTL differential (RS422)
Output current	RS 422 ± 40 mA (ET7272) NPN O.C. -16 mA (2k Ω int. pull up)
Commutation	U, V, W
Signal shape	trapezoid commutation
Phasing	U leads V leads W by 120°
Tolerance N to U	$\pm 1^\circ$ mech. index pulse center to U channel edge (see signal diagram)
Connection	16 pins double row header, axial or radial Mating connector with 28 AWG cable available
Reference signal	N
Index pulse width	90° (A gated B)

DIMENSIONAL DRAWINGS

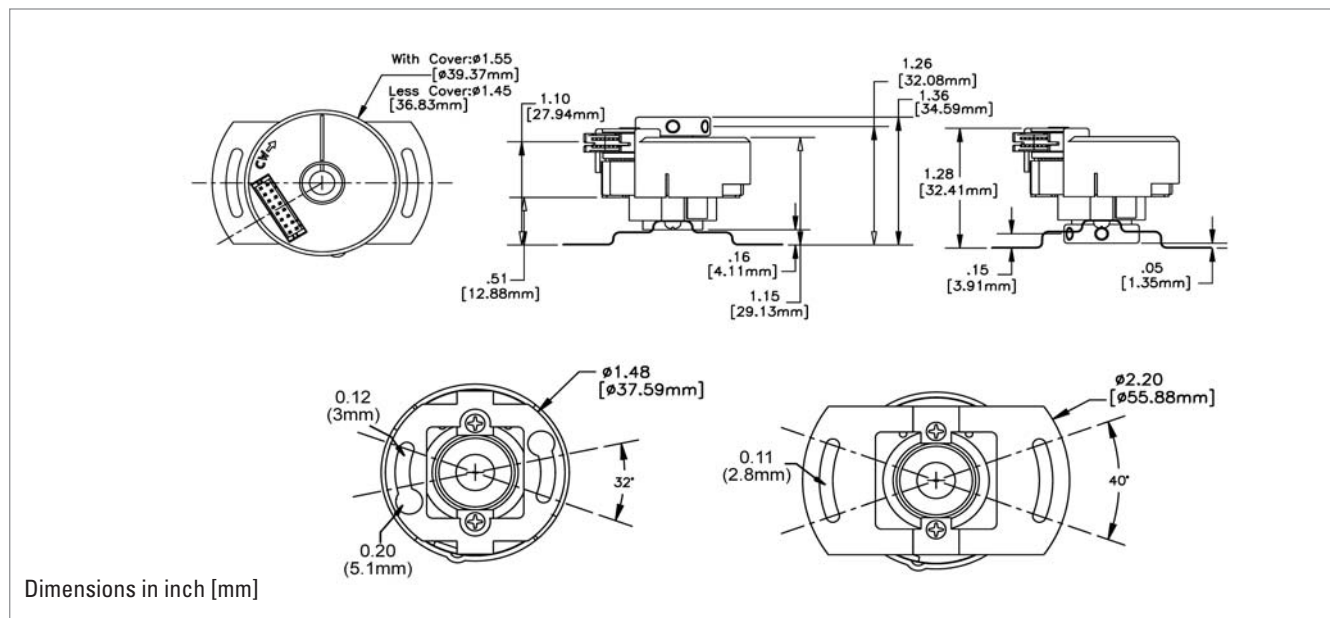

for AC Synchronous & BLDC Motors

SIGNAL DIAGRAM

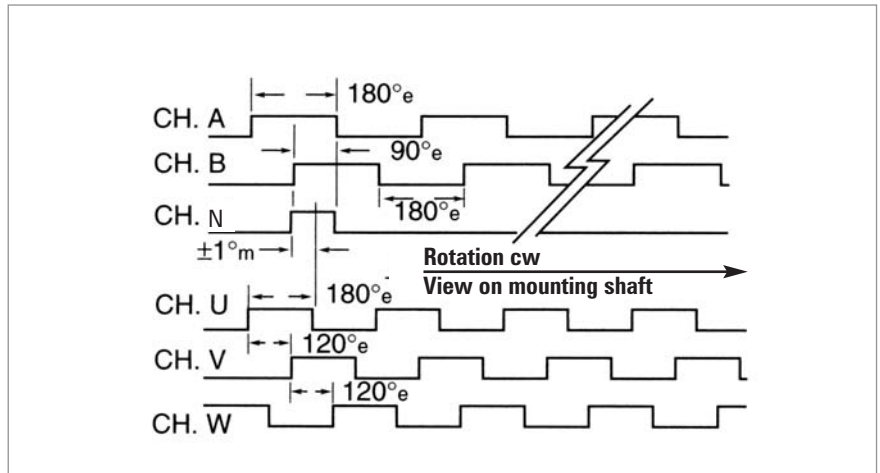

CONNECTION

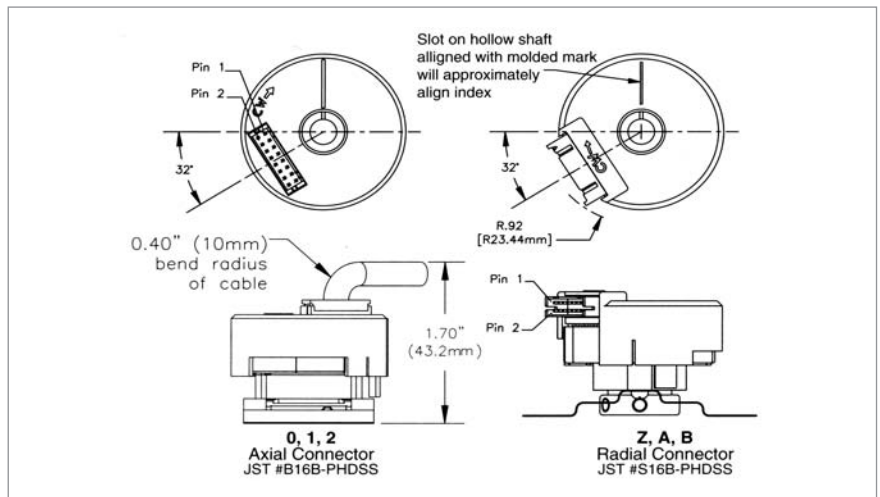

CONNECTION DIAGRAM

Pin	Function ¹	Colour
1	VCC	red
2	U	brown
3	GND	black
4	V	grey
5	A	blue
6	W	white
7	\bar{A}	blue/black
8	-	-
9	B	green
10	\bar{U}	brown/black
11	\bar{B}	green/black
12	\bar{V}	grey/black
13	N	violet
14	\bar{W}	white/black
15	\bar{N}	violet/black
16	-	-

¹ Availability of function depends on version

for AC Synchronous & BLDC Motors

ORDERING INFORMATION

Type	Pulses ppr incremental ²	Poles commutation ²	Mounting	Electrical ¹	Shaft	Connection ³
<input type="checkbox"/>	<input type="checkbox"/> /	<input type="checkbox"/> -	<input type="checkbox"/>	<input type="checkbox"/>	<input type="checkbox"/>	<input type="checkbox"/>
F14	0200 0400 0500 1000 1024 2000 2048 2500 4096 5000	0 without 4 4 pole 6 6 pole 8 8 pole A 10 pole	tether 0 without tether 1 1.181 " (30 mm) 3 1.811 " (46 mm)	incremental only, < 2 048/0 (ppr/poles) 0 U _{inc} =DC 5 V; output _{inc} =NPN-O.C. incremental only without commutation 3 U _{inc} =DC 5 V; output _{inc} =RS 422 incremental plus commutation signals 6 U _{inc} =DC 5 V; output _{inc} =RS 422, U _{com} =DC 5 V; output _{com} =NPN-O.C. 9 U _{inc} =DC 5 V; output _{inc} =RS 422, U _{com} =DC 5 V; output _{com} =RS 422	Clamping ring front 0 1/4" 4 6 mm 5 8 mm Clamping ring rear A 1/4" E 6 mm F 8 mm	Axial plug 0 without cable 1 30 cm cable 2 60 cm cable Radial plug Z without cable A 30 cm cable B 60 cm cable

¹ U_{inc}: Supply voltage incremental,
U_{com}: Supply voltage commutation (only if commutation is selected)

² allowed combinations see available combinations (pulses/poles)

³ Other lengths in multiples of 30 cm, e.g. 90 cm = 3 / 90 cm = C etc.

Available combinations (pulses/poles)

Pulses ppr	Number of poles				
	0	4	6	8	10 (=A)
0200	X				
0400	X	X	X	X	X
0500	X	X	X	X	X
1000	X	X	X	X	X
1024	X	X	X	X	X
2000	X	X	X	X	X
2048	X	X	X	X	X
2500	X	X	X	X	X
4096	X	X	X	X	X
5000	X	X	X	X	X

for AC Synchronous & BLDC Motors



- Compact hollowshaft motor encoder, ideal for BLDC, DC-Servo and Stepper feedback
- Incremental & commutation
- Phased Array Technology
- Up to 10000 ppr
- Frequency response to 500 kHz
- Operating temperature up to 120°C
- Through hollow shaft up to diameter 12.7 mm
- Stator coupling
- External diameter 50 mm
- Cable plug-in radial/axial

GENERAL INFORMATION

The type F18 encoder provides high performance, cost effective feedback for stepper and servo motor controls. The F18 offers compact package dimensions and a pluggable pin header. A compliant tether allows easy mounting with high tolerance to motor shaft movement and 30 degrees of adjustment to align the signal outputs to the shaft position.

A superior optical configuration allows for generous internal component clearance eliminating potential damage at high ambient operating temperatures. High temperature rated grease is standard for extended bearing life. No special tools are required for installation.

The use of optically-generated signals for Brushless DC (BLDC) servo control provides higher accuracy and reliability by eliminating the hysteresis found in competitive units with hall effect sensors, ensuring maximum performance and reliability of the servo system.

NUMBER OF PULSES

500, 512, 1000, 1024, 2000, 2048, 2500, 4096, 5000, 8192, 10000;
optional additional 4, 6, 8, 10, 12 or 16 pole commutation signals

TECHNICAL DATA
mechanical

Shaft	Through hollow shaft
Shaft diameter	6, 8, 10, 12 mm; <i>1/4", 3/8", 7/16", 1/2"</i>
Shaft tolerance	+0.025 / -0.000 mm
Moment of inertia	37.3 gcm ²
Axial endplay of mating shaft	±1.5 mm
Radial runout of mating shaft	0.05 mm (includes shaft perpendicularity)
Max. speed	(Frequency / ppr) x 60 or 12000 min ⁻¹ , whichever is less
Bearing life	(3.6 x 10 ⁹) / min ⁻¹ [hours] e.g. 605 000 hours at 6 000 min ⁻¹
Protection class	IP40 (with cover)
Operating temperature	0 ... +120 °C
Storage temperature	-40 ... +120 °C
Shock resistance	1000 m/s ² (11 ms)
Vibration resistance	25 m/s ² (5...2000 Hz)
Material housing	Aluminium

for AC Synchronous & BLDC Motors

TECHNICAL DATA electrical

Supply voltage	DC 5 V $\pm 10\%$
Max current w/o load	Max. 150 mA (incremental) Max. 175 mA (incremental +commutation)
Incremental signals	A, B
Resolution	Max. 10 000 ppr (see ordering information)
Accuracy	Incremental 2' (2 edges to any edges)
Phasing A to B	A leads B by 90° ccw (view on mounting shaft)
Phasing tolerance A to B	$\pm 45^\circ$
Max. output frequency	250 kHz up to 1 024 ppr 500 kHz > 1 024 ppr
Signal level	TTL differential (RS422)
Output current	RS 422 ± 40 mA (ET7272) NPN O.C. -16 mA (2k Ω int. pull up)
Commutation	U, V, W
Signal shape	trapezoid commutation
Phasing	U leads V leads W by 120°
Tolerance N to U	$\pm 1^\circ$ mech. index pulse center to U channel edge (see signal diagram)
Connection	16 pins double row pin header, axial or radial Mating connector with 28 AWG cable available
Reference signal	N
Index pulse width	90° (A gated B)

DIMENSIONAL DRAWINGS

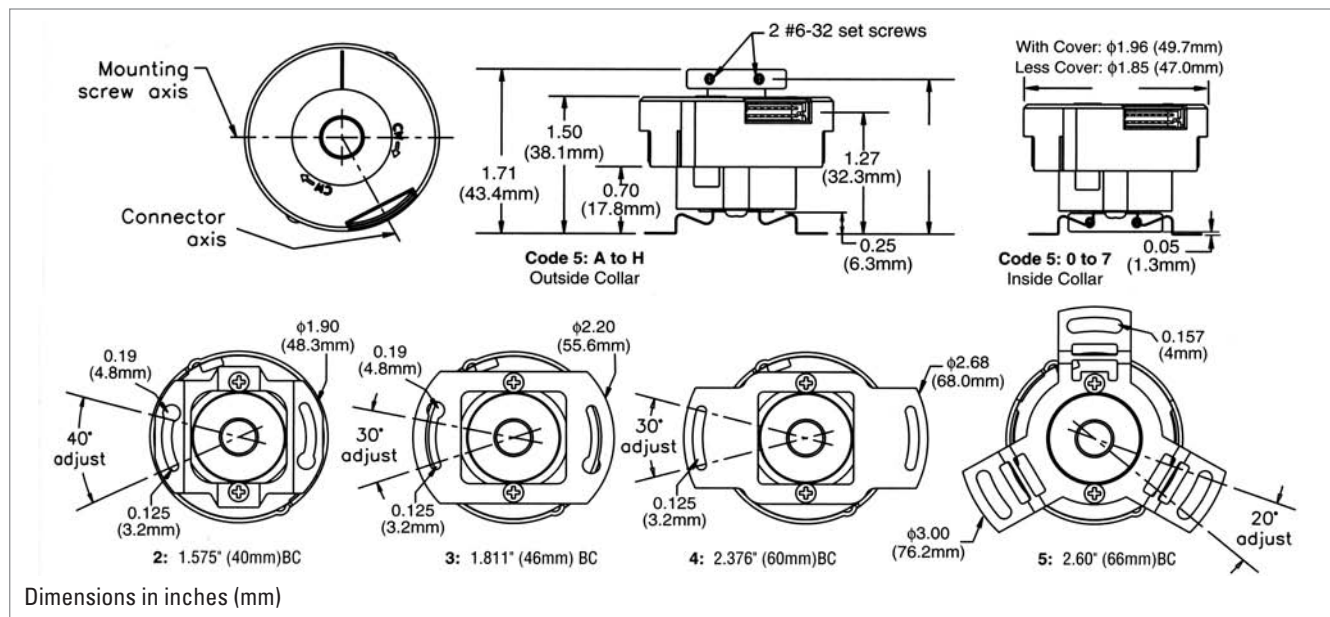

for AC Synchronous & BLDC Motors

SIGNAL DIAGRAM

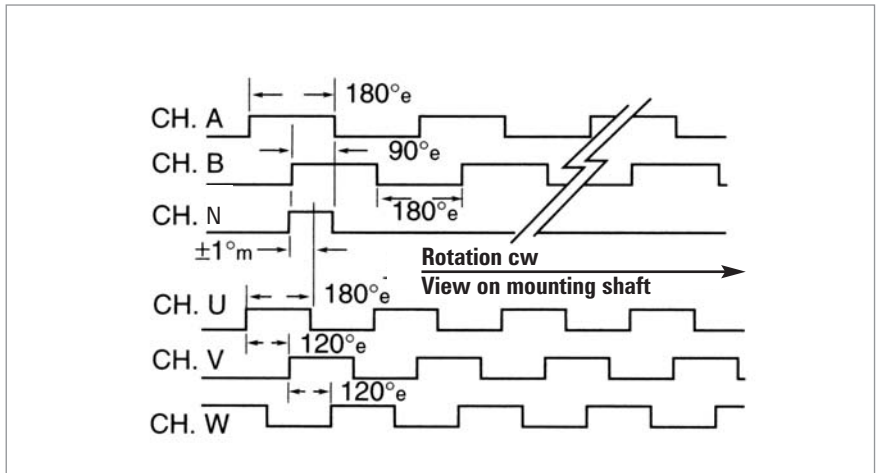

CONNECTION

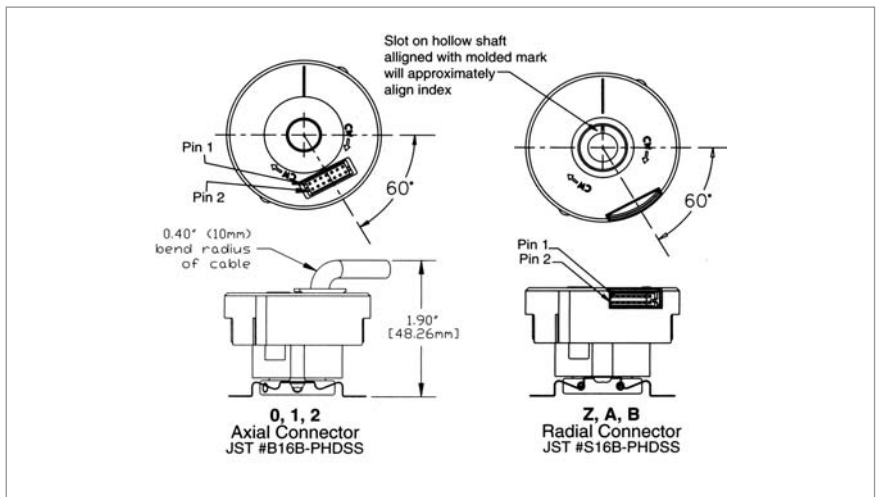

CONNECTION DIAGRAM

Pin	Function ¹	Colour
1	VCC	red
2	U	brown
3	GND	black
4	V	grey
5	A	blue
6	W	white
7	\bar{A}	blue/black
8	-	-
9	B	green
10	\bar{U}	brown/black
11	\bar{B}	green/black
12	\bar{V}	grey/black
13	N	violet
14	\bar{W}	white/black
15	\bar{N}	violet/black
16	-	-

¹ Availability of function depends on version

for AC Synchronous & BLDC Motors

ORDERING INFORMATION

Type	Pulses ppr incremental ²	Poles commutation ²	Mounting	Electrical ¹	Shaft	Connection ³
<input type="checkbox"/>	<input type="checkbox"/> / <input type="checkbox"/>	<input type="checkbox"/> - <input type="checkbox"/>	<input type="checkbox"/>	<input type="checkbox"/>	<input type="checkbox"/>	<input type="checkbox"/>
F18	0500 0512 1000 1024 2000 2048 2500 4096 5000 8192 10E3 = 10000	0 without 4 4 pole 6 6 pole 8 8 pole A 10 pole C 12 pole G 16 pole	tether 0 without tether 2 1.575" (40 mm) TK 3 1.811" (46 mm) TK 4 2.376" (60 mm) TK 5 2.60" (66 mm) TK	incremental only, < 2048/0 (ppr/poles) 0 U _{inc} =DC 5 V; output _{inc} =NPN-O.C. incremental only without commutation 3 U _{inc} =DC 5 V; output _{inc} =RS 422 incremental plus commutation signals 6 U _{inc} =DC 5 V; output _{inc} =RS 422, U _{com} =DC 5 V; output _{com} =NPN-O.C. 9 U _{inc} =DC 5 V; output _{inc} =RS 422, U _{com} =DC 5 V; output _{com} =RS 422	Clamping ring front 0 1/4" 4 6 mm 1 3/8" 5 8 mm 2 7/16" 6 10 mm 3 1/2" 7 12 mm Clamping ring rear A 1/4" E 6 mm B 3/8" F 8 mm C 7/16" G 10 mm D 1/2" H 12 mm	Axial plug 0 without cable 1 30 cm cable 2 60 cm cable Radial plug Z without cable A 30 cm cable B 60 cm cable

¹ U_{inc}: Supply voltage incremental,
U_{com}: Supply voltage commutation (only if commutation is selected)

² allowed combinations see available combinations (pulses/poles)

³ Other lengths in multiples of 30 cm, e.g. 90 cm = 3 / 90 cm = C etc.

Available combinations (pulses/poles)

Pulses ppr	Number of poles						
	0	4	6	8	10 (=A)	12 (=C)	16 (=X)
0500	X	X	X	X	X	X	
0512	X	X	X	X			
1000	X	X	X	X	X	X	
1024	X	X	X	X		X	
2000	X	X	X	X	X	X	
2048	X	X	X	X	X	X	X
2500	X	X	X	X	X	X	
4096	X	X	X	X	X	X	X
5000	X	X	X	X	X	X	
8129	X	X	X	X	X	X	X
10E3 = 10000	X	X	X	X	X	X	

PRELIMINARY

Motor Feedback Systems Type RF 53 for AC Synchronous & BLDC Motors

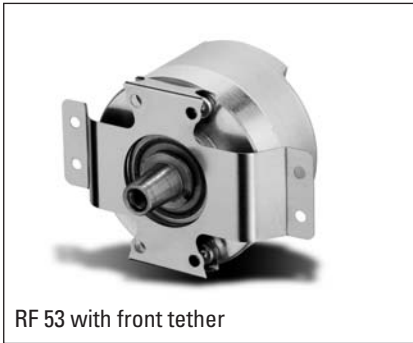

RF 53 with front tether



RF 53 with rear tether

- Solid shaft motor encoder for BLDC and gearless elevator traction machines
- Incremental & Commutation
- up to 10 000 ppr
- up to +120 °C operating temperature
- IP54
- Housing diameter 53 mm

NUMBER OF PULSES

500 to 10 000 ppr;
optional additional 4, 6, 8, 10, 12, 16, 20, 24 or 32 pole commutation signals

TECHNICAL DATA mechanical

Housing diameter	53 mm
Shaft	cone solid shaft
Flange	Spring tether
Protection class shaft input	IP54
Protection class housing	IP54
Shaft load axial/ radial	20 / 90 N
Axial runout of mating shaft	±1.4 mm
Radial runout of mating shaft	±0.18 mm
Max. speed	12 000 U/min (short term) 5 000 U/min (continuous)
Max. operating temperature	-20°C ... +120°C
Max. storage temperature	-40°C ... +120°C
Relative humidity	95% non-condensing
Vibration resistance	1 000 m/s ²
Shock resistance	25 m/s ²
Material shaft	Stainless steel
Material housing	Aluminium
Weight	200 g
Connection	Cable Cable with Sub-D connector

Motor Feedback Systems Type RF 53

for AC Synchronous & BLDC Motors

TECHNICAL DATA electrical

Supply voltage	DC 5 ±10%
Max. current w/o load	100 mA
Code	Incremental with commutation option, optical
Tolerance	
Incremental signals	±2,5 arc-mins. max. (edge to edge)
Commutation	±6 arc-mins. max.
Phasing	A to B by 90° and U to W by 120°
Minimum edge separation	A to B 45°
Index pulse width	90° gated A and B high
Output frequency	max. 100 kHz
Output circuit	Differential line driver (ET7272), 40 mA max. Open Collector, max. 8 mA; Pull up with 2,0 kOhm
Output versions	RS 422 (incr.): A, B, N, \bar{A} , \bar{B} , \bar{N} RS 422 (incr. + com.): A, B, N, \bar{A} , \bar{B} , \bar{N} , U, V, W, \bar{U} , \bar{V} , \bar{W} RS 422 (incr.) + OC-NPN (com.): A, B, N, \bar{A} , \bar{B} , \bar{N} , U, V, W OC-NPN (incr.): A,B,N

DIMENSIONAL DRAWINGS

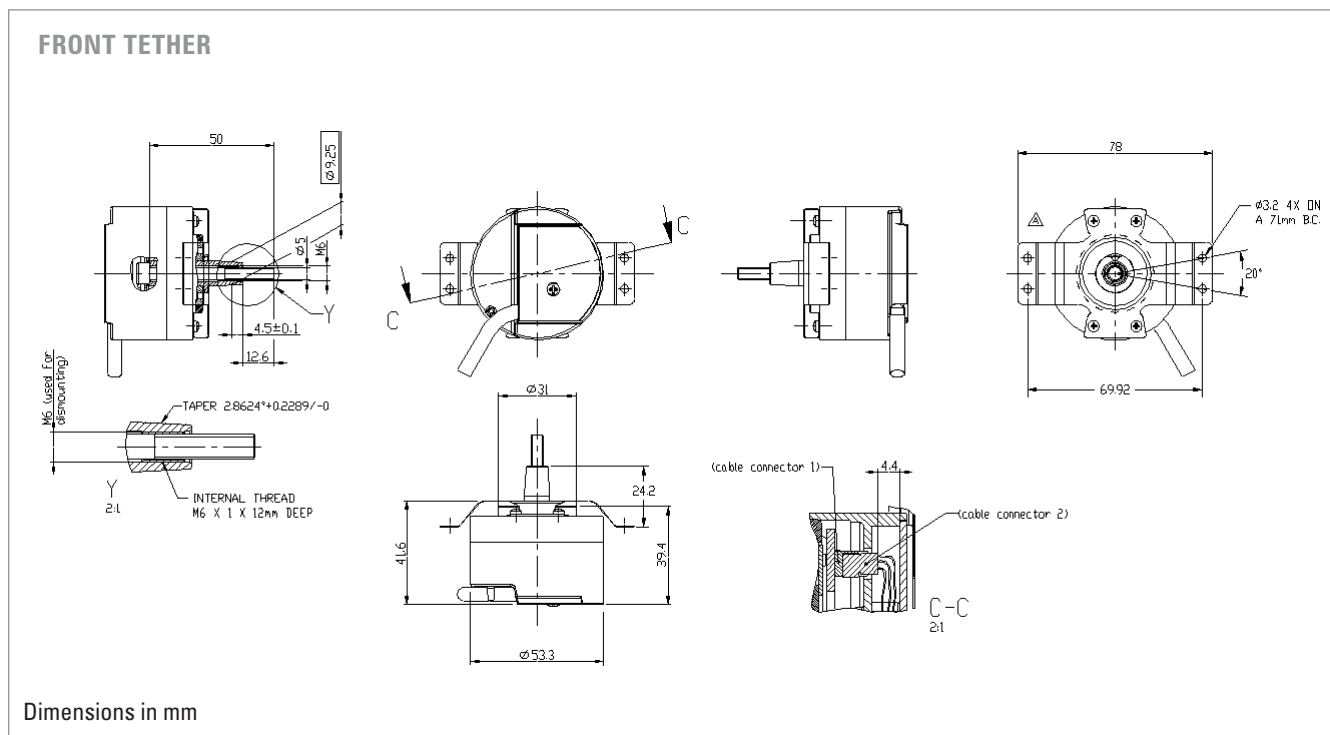

Motor Feedback Systems Type RF 53 for AC Synchronous & BLDC Motors

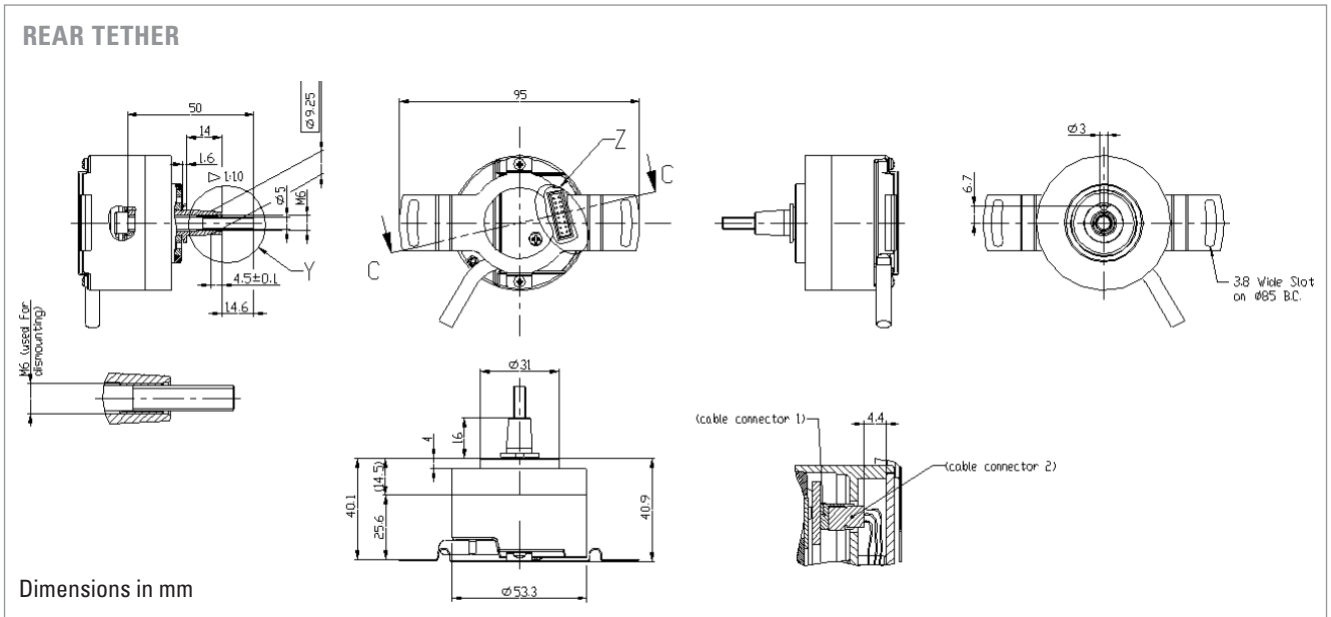

SIGNAL FORMAT

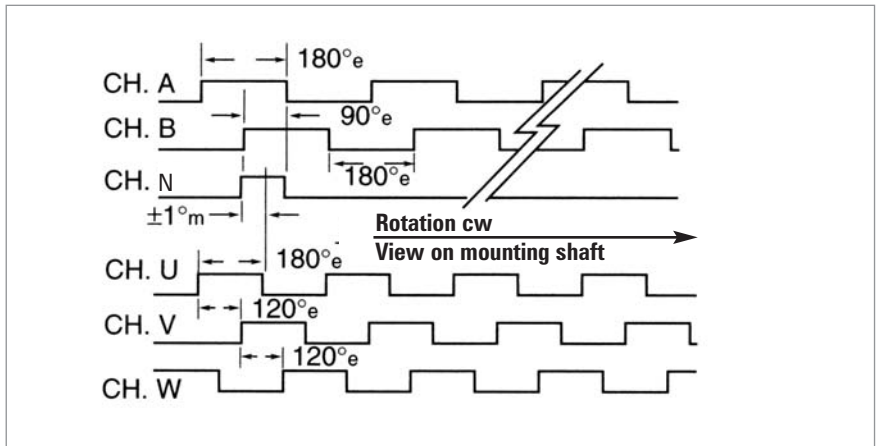

PIN ASSIGNMENT

PIN	Signal	Color	SUB-D 15 PIN
1	DC 5 V	red	13
2	U	brown	7
3	0 V	black	14
4	V	grey	9
5	A	blue	1
6	W	white	11
7	\bar{A}	blue/black	2
8	N.C.		
9	B	green	3
10	\bar{U}	brown/black	8
11	\bar{B}	green/black	6
12	\bar{V}	grey/black	10
13	N	violet	N.C.
14	\bar{W}	white/black	12
15	\bar{N}	violet/black	N.C.
16	N.C.		

PCB Connector

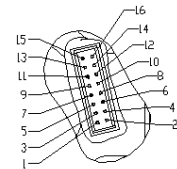

Sub-D- Connector

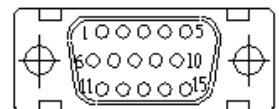

for AC Synchronous & BLDC Motors

ORDERING INFORMATION

Type	Pulses ppr incremental ¹	Poles commutation ²	Spring tether	Electrical	Connection
<input type="checkbox"/>	<input type="checkbox"/> /	<input type="checkbox"/> -	<input type="checkbox"/>	<input type="checkbox"/>	<input type="checkbox"/>
RF53	0500 0512 1000 1024 2000 2048 2500 4096 5000 8192 10E3 = 10000	0 without 4 4 pole 6 6 pole 8 8 pole A 10 pole C 12 pole G 16 pole K 20 pole O 24 pole W 32 pole	1 rear mount 2 front mount	Incremental only 0 $U_{inc}=DC\ 5\ V$; $output_{inc}=O.C.-NPN$ ³ 3 $U_{inc}=DC\ 5\ V$; $output_{inc}=RS\ 422$ Incremental plus Commutation signals 6 $U_{inc}=DC\ 5\ V$; $output_{inc}=RS\ 422$ $U_{com}=DC\ 5\ V$; $output_{com}=O.C.-NPN$ 9 $U_{inc}=DC\ 5\ V$; $output_{inc}=RS\ 422$, $U_{com}=DC\ 5\ V$; $output_{com}=RS\ 422$	0 PCB connector 16 pole A Cable 0.5 m B Cable 1 m C Cable 2 m D Cable 3 m E Cable 7 m K Cable 10 m P Cable 15 m 1 Sub-D connector at 3 m cable 2 Sub-D connector at 5 m cable 3 Sub-D connector at 10 m cable
¹ Option redundant on request ² allowed combinations see available combinations pulses/ poles ³ only available with pulses/poles $\leq 2048/0$					

Available combinations (pulses/poles)

Pulses ppr	Number of poles									
	0	4	6	8	10 (=A)	12 (=C)	16 (=G)	20 (=K)	24 (=O)	32 (=W)
0500	X	X	X	X	X	X				
0512	X	X	X	X						
1000	X	X	X	X	X	X				
1024	X	X	X	X		X				
2000	X	X	X	X	X	X				
2048	X	X	X	X	X	X	X	X	X	X
2500	X	X	X	X	X	X				
4096	X	X	X	X	X	X	X	X	X	X
5000	X	X	X	X	X	X				
8192	X	X	X	X	X	X	X	X	X	X
10E3 =10000	X	X	X	X	X	X				

PRELIMINARY



GENERAL INFORMATION

TECHNICAL DATA mechanical

Absolute Motor Feedback Systems Type AD 36 for AC Synchronous & BLDC Motors

- For brushless servo motors
- Resolver size 15 compatible
- Through hollow shaft 8 mm
- 19 Bit Singleturn + 12 Bit Multiturn
- + 120°C operating temperature
- 10.000 rpm continuous operation
- Geared optical multiturn
- SSI or BiSS interface
- Sinewave 1 Vpp
- Bandwidth 500kHz

The AD36 is an absolute encoder with a true geared Multiturn, optical sensing technology and 36 mm diameter. Unique is the through hollow shaft which enables an assembly that is compatible with resolver size 15. The mechanical design consists of two ball bearings and a flexible torque support. The AD36 complements the *ACURO-DRIVE* series and is appropriate for use within BLDC servo motors with small frame sizes.

Fully digital control loop

The new and completely digital OptoAsic technology enables the transition to a truly digital drive system. The conventional absolute encoders still have analog sine wave signals for the feedback of speed and position data. The AD36, however, provides fully digital position data up to 19 Bit (Singleturn) and 12 Bit (Multiturn) over the **BiSS** interface with a variable clock rate up to 10 MHz. **BiSS** is the only open high speed bidirectional sensor interface available on the market.

Backward compatibility to most of the existing drives is realized through the variant with SSI interface together with 2048 sine –cosine periods per revolution.

Integrated diagnostic system

The AD36 has an integrated diagnostic system that controls and regulates the internal signals. Maximum motor uptime is achieved through the pre warning in case of any system error or aging effects well before they affect the function of the encoder. A code plausibility check guarantees that the output data represents always the true position. Also the operating temperature can be measured and read out with 8 Bit resolution. If programmable limits are exceeded or under run this is indicated over warn and alarm bits.

Housing diameter	37,5 mm
Shaft diameter	8 mm
Protection class housing	IP40
Protection class shaft	IP40
Max. speed	Continuous operation 10 000 min ⁻¹ Short term operation 12 000 min ⁻¹
Torque	0,01 Nm
Moment of inertia	25 gcm ²
Spring tether (hollow shaft)	
Tolerance axial	± 0,5 mm
Tolerance radial	± 0,05 mm
Vibration resistance (IEC 68-2-6)	100 m/ s ² (10 - 500 Hz)
Shock resistance (IEC 68-2-27)	1000 m/ s ² (6 ms)
Operating temperature	-15 ...+120°C
Storage temperature	-15 ...+85°C
Material shaft/ housing	Aluminum
Weight ST/ MT	80 g/ 130 g

Absolute Motor Feedback Systems Type AD 36 for AC Synchronous & BLDC Motors

TECHNICAL DATA electrical

Supply voltage	DC 5 V (-5 %/ +10 %) or DC 7-30 V
Current consumption ST/ MT	50 mA/ 100 mA
Lines/ Drives	Clock and Data/ RS422
Output code	Gray
Resolution Singleturn	SSI: 12 - 17 Bit BiSS: 12 - 19 Bit
Resolution Multiturn	SSI: 12 Bit BiSS: 12 Bit
Incremental signals	Sine - Cosine 1 Vpp
No. of increments	2048
3 dB limiting frequency	500 kHz
Absolute accuracy	±35"
Repeatability	±7"
Alarm output	alarm bit (SSI), warning bit and alarm bit (BiSS)
Connection	Cable PCB-Connector, 12 pole

DIMENSIONAL DRAWINGS

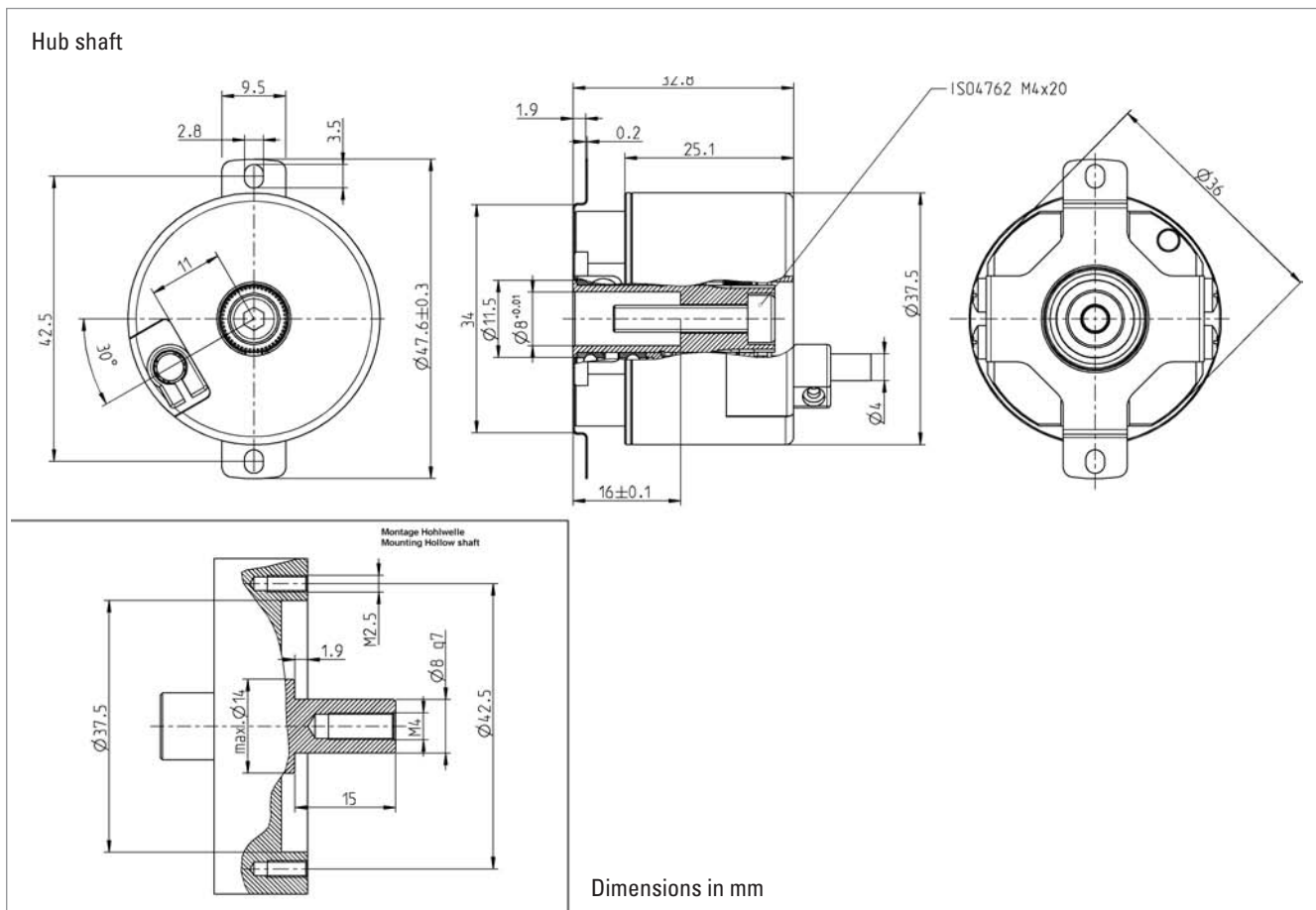

Absolute Motor Feedback Systems Type AD 36 for AC Synchronous & BLDC Motors

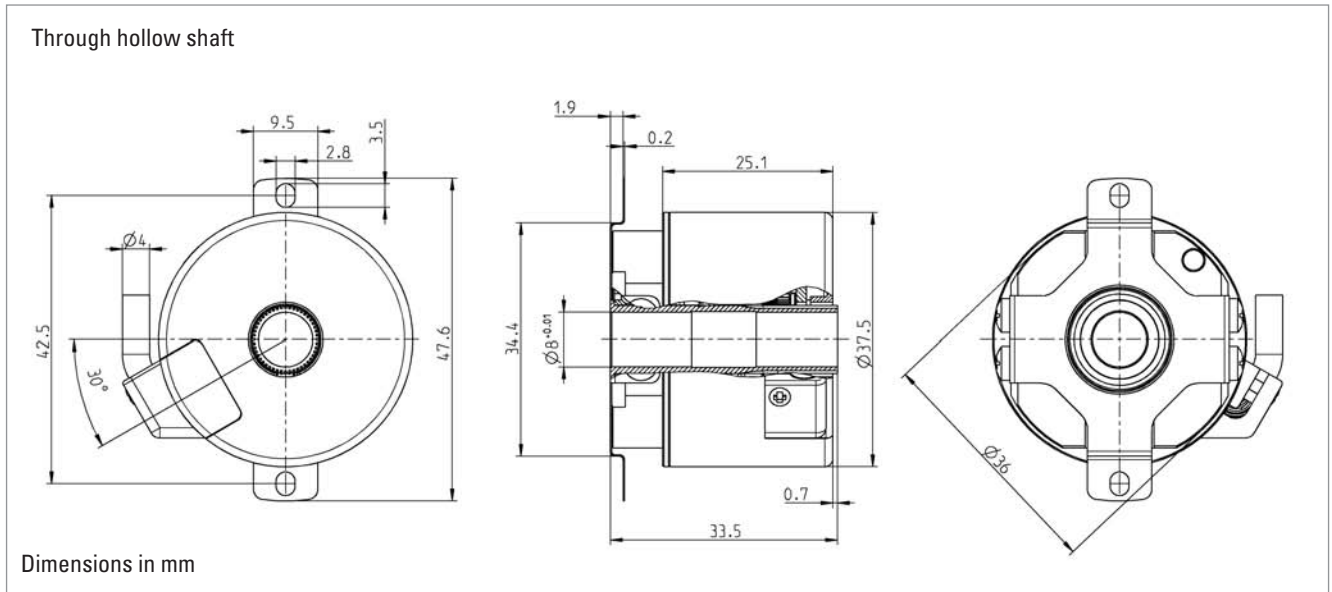

PIN ASSIGNMENT

Colour new	Colour old	PIN	Signals
grey	violet	1a	Data
white/green	green	2a	A +
black	brown/ green	3a	0 V Sensor
red/blue	blue	4a	B +
green	brown	5a	Clock
violet	red/ black	6a	5 V Sensor
white	yellow/ black	1b	DC 5 V/ 7 - 30 V
yellow	white	2b	Clock
grey/pink	red	3b	B -
brown	white/ green	4b	0 V (U _N)
brown/green	yellow	5b	A -
pink	black	6b	Data

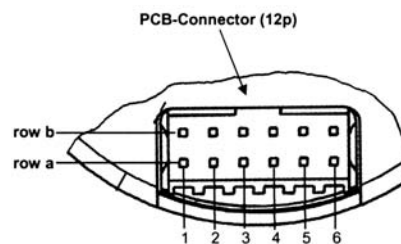

Connector:
12 pin PCB connector
Manufacture Berg
Type: Minitec

ORDERING INFORMATION

Type	Resolution	Supply voltage	Flange, Protection, Shaft	Interface	Connection
<input type="checkbox"/>	<input type="checkbox"/>	<input type="checkbox"/>	<input type="checkbox"/>	<input type="checkbox"/>	<input type="checkbox"/>
AD 36	0012 12 Bit ST 0013 13 Bit ST 0014 14 Bit ST 0017 17 Bit ST 0019 19 Bit ST (BiSS) 1213 12 Bit MT+13 Bit ST 1217 12 Bit MT+17 Bit ST 1219 12 Bit MT +19 Bit ST (BiSS)	A DC 5 V E DC 7 - 30 V	F0C Spring tether, IP40, 8 mm trough hollow shaft F0R Spring tether, IP40, 8 mm hub shaft	SC SSI Gray +1 Vpp BI BiSS	0 PCB-connector, 12 pole B Cable radial 0.5m

Absolute Motor Feedback Systems Type AD 58 for AC Synchronous & BLDC Motors



- For brushless servo motors
- All-digital and highspeed
- + 120°C operating temperature
- 10.000 rpm continuous operation
- Geared optical multiturn
- SSI or BiSS interface
- Option Sinewave 1 Vpp: Harmonic distortion less than 1%
- Bandwidth 500kHz

GENERAL INFORMATION

The AD58 is an absolute encoder with a true geared Multiturn and optical sensing technology: The mechanical design consists of two ball bearings and a flexible torque support. The AD58 is ideally suited for integration into BLDC servo motors for demanding applications such as CNC precision machining and printing in professional quality. Through its low current consumption the AD58 is contributing to lowering cost of ownership.

Fully digital control loop

The new and completely digital OptoAsic technology enables the transition to a truly digital drive system. The conventional absolute encoders still have analog sine wave signals for the feedback of speed and position data. The AD58, however, provides fully digital position data up to 22 Bit (Singleturn) and 12 Bit (Multiturn) over the BiSS interface with a variable clock rate up to 10 MHz. This corresponds a singleturn resolution of more than 4 million measured steps.

TECHNICAL DATA mechanical

Housing diameter	58 mm
Protection class housing	IP40
Protection class shaft	IP40
Flange	Hubshaft with tether or Konus
Shaft diameter	Cone 10 mm
Max. speed	Continuous operation 10 000 min ⁻¹ Short term operation 12 000 min ⁻¹
Torque	0,01 Nm
Moment of inertia	3.8 x 10 ⁻⁶ kgm ²
Spring tether (hollow shaft)	
Tolerance axial	± 0,5 mm
Tolerance radial	± 0,1 mm
Vibration resistance (IEC 68-2-6)	100 m/ s ² (10 - 2000 Hz)
Shock resistance (IEC 68-2-27)	1000 m/ s ² (6 ms)
Operating temperature	-15 ...+120°C
Storage temperature	-15 ...+85°C (because of packing)
Weight ST/ MT	260 g/ 310 g

Absolute Motor Feedback Systems Type AD 58 for AC Synchronous & BLDC Motors

TECHNICAL DATA electrical

Supply voltage	DC 5 V (-5 %/ +10 %)
Current consumption ST/ MT	50 mA/ 100 mA
Interface	Standard SSI or BiSS
Lines/ Drives	Clock and Data/ RS422
Output code	Binary or Gray
Resolution Singleturn	13 Bit (SSI), max. 22 Bit (BiSS)
Resolution Multiturn	12 Bit
Incremental signals	Sine - Cosine 1 Vpp
No. of increments	2048
3 dB limiting frequency	500 kHz
Absolute accuracy	±35"
Repeatability	±7"
Alarm output	alarm bit (SSI), warning bit and alarm bit (BiSS)
Connection	PCB-Connector, 12 pole

DIMENSIONAL DRAWINGS

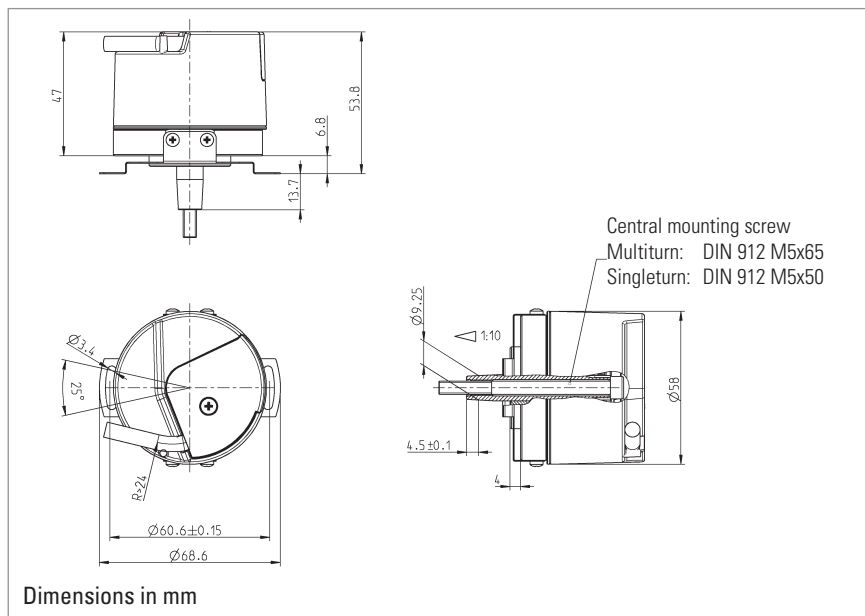

CONNECTION DIAGRAM

row b	DC 5/7-30 V (U _B) gr/pk	Clock wt	B - rd	0V (U _N) wt/gn	A - ye	Data bk
row a	Data / vio	A + gn	0V Sensor bn/gn	B + bl	Clock / bn	5V Sensor rd/bl
Pin	1	2	3	4	5	6

CONNECTION ENCODER SIDE

12 pin PCB connector
manufacture Berg, type Minitex

Screen is connected over a length of 10 mm
with encoder housing



Absolute Motor Feedback Systems Type AD 58 for AC Synchronous & BLDC Motors

ORDERING INFORMATION

Type	Resolution	Supply voltage	Flange, Protection, Shaft	Interface	Connection
□	□	□	□	□	□
AD58	0013 13 Bit ST 0022 22 Bit ST (BiSS) 1213 12 Bit MT+13 Bit ST 1222 12 Bit MT+22 Bit ST (BiSS)	A DC 5 V E DC 10 - 30 V	1.0K Hubshaft with tether, IP40, Cone 10 mm	SC SSI Gray +1 Vpp BI BiSS (digital)	0 PCB connector 12 pole B PCB connector 12 pole with mating connector and 0.5m cable

Motor Feedback Systems - Sine-wave Type S21 for AC Synchronous & BLDC Motors



- Wide operating temperature range of $-15\text{ }^{\circ}\text{C}$ up to $+120\text{ }^{\circ}\text{C}$, therefore optimum use of motor capacity
- High limiting frequency with excellent signal quality, allowing highest peak speeds and reduced non-productive time wastage
- Excellent immunity to interference (EN 61000-4-4, Class 4)
- High functional safety due to signal control and system monitoring (under-voltage, pollution, disc damage, end of LED service life)
- High signal quality through control and error compensation

GENERAL INFORMATION

The S21 has been constructed in line with the International Standard Resolver dimension 21, i.e. 2.1" (approx. 53 mm) and as a result is also suitable for smaller sized motors. The simplicity of connection rounds off advantages of the S21. The integrated cable plug connector combines the advantages of the plug with those of a cable connection. This leads to a fast, economical and space-saving installation.

TECHNICAL DATA electrical

General design	as per DIN EN 61010-1, protection class III, contamination level 2, over voltage class II
Supply voltage	DC 5 V $\pm 10\%$ (SELV)
Max. current w/o load	120 mA
Incremental signals A,B	Sine - Cosine 1 Vpp
Number of pulses	2048
Accuracy	$\pm 35''$
Repeatability	$\pm 7''$
Max frequency output	500 kHz
Reference signal: R	$> 0.4\text{ V}$ (1 pulse per rev.)
Commutation signals: C, D	Sine - Cosine 1 Vpp (1 period per rev.)
Connection	PBC connector with cable

TECHNICAL DATA mechanical

Shaft form	Cone 1/10
Shaft variations	Tapered solid shaft (Tapered hollow shaft on request)
Shaft diameter	10 mm
Shaft load tapered solid shaft	radial 90 N, axial 20 N
Compensation	axial $\pm 0.5\text{ mm}$, radial $\pm 0.1\text{ mm}$
Nominal speed	$12\,000\text{ min}^{-1}$
Max. speed	$15\,000\text{ min}^{-1}$ ($< 1\text{ s}$)
Torque	$\leq 1\text{ Ncm}$
Protection class	IP40
Operating temperature	$-15\text{ }^{\circ}\text{C}$... $+120\text{ }^{\circ}\text{C}$
Storage temperature	-20 ... $+80\text{ }^{\circ}\text{C}$
Vibration resistance (IEC 68-2-6)	$\leq 100\text{ m/s}^2$ (10 ... 2000 Hz)
Shock resistance (IEC 68-2-27)	$\leq 1\,000\text{ m/s}^2$ (6 ms)
Material housing	Aluminium

Motor Feedback Systems - Sine-wave Type S21 for AC Synchronous & BLDC Motors

S21 SIGNALS

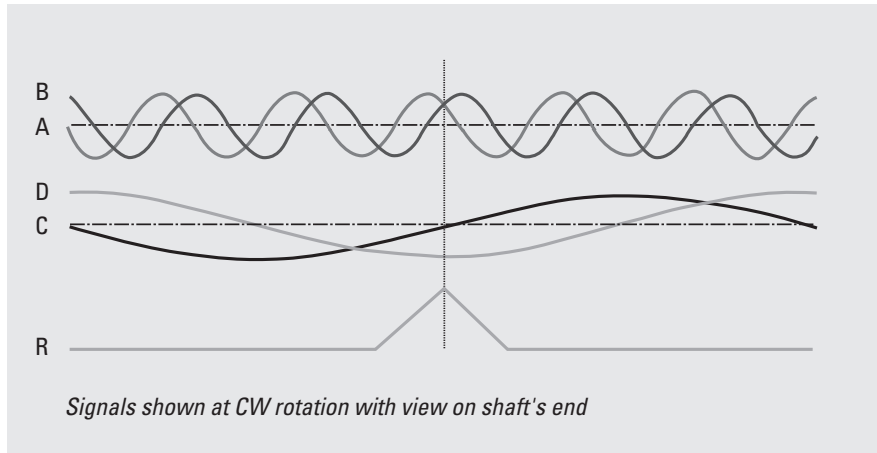

The incremental signals A and B and the zero signal R are differential voltage signals. The differential signal level is 1 Vpp. The zero signal appears once per revolution and reaches its maximum value at the angle where the amplitudes of A and B Signals are equal. The coarse tracks C and D deliver one sinewave period per revolution and are utilized to determine the absolute rotor position of Brushless DC motors for startup commutation. All signals have a DC offset of 2.5 V.

S21 SIGNAL QUALITY

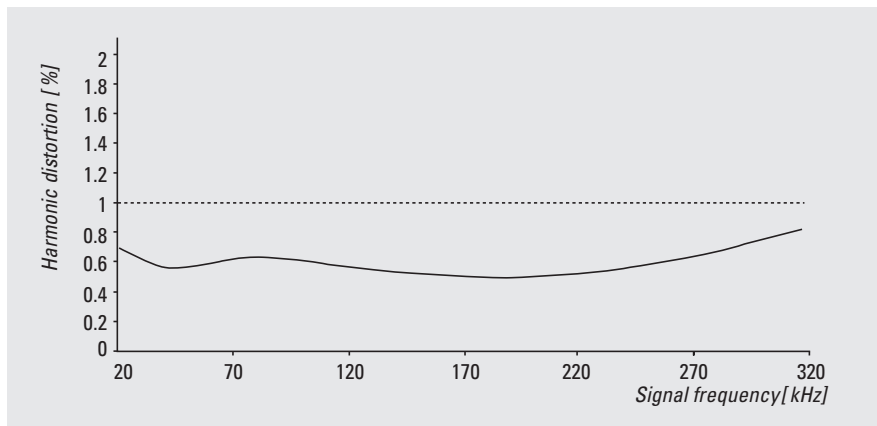

The quality of the servo loop is determined to a large extent by the absence of harmonics in the encoder's sinewave signals, particularly at low speed. In order to achieve high interpolation factors in the sequencing control, the incremental sinewave signals A and B are available with a harmonic distortion significantly under 1% throughout the specified temperature range. This delivers excellent synchronism and a high level of positional accuracy with servo axes.

PCB-CONNECTOR PIN OUT

Row a	5 V Sense rd/bl	D- vio	B- rd	R- pk	0 V Sense gn/br	A- ye	C- br
Row b	wt C+	gn A+	wt/gn GND	gr R+	bl B+	bk D+	gr/pk U _B
Pin	7	6	5	4	3	2	1

Motor Feedback Systems - Sine-wave Type S21 for AC Synchronous & BLDC Motors

DIMENSIONAL DRAWINGS TAPERED SOLID SHAFT

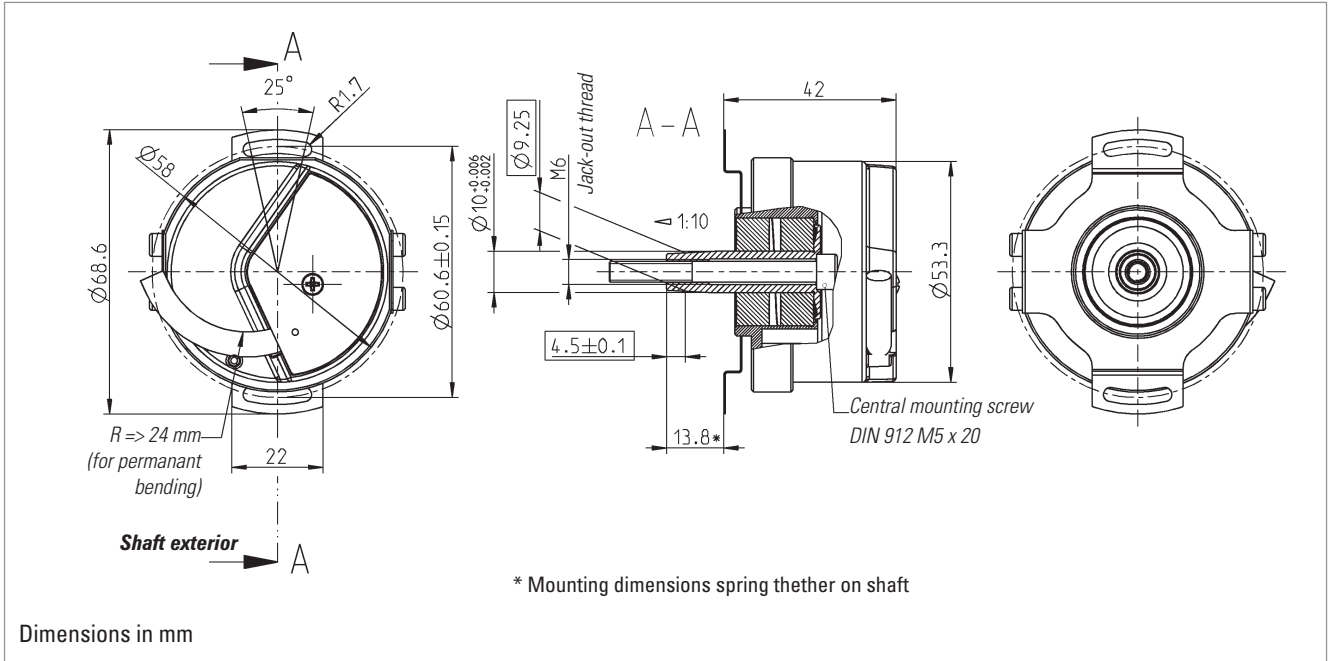

ORDERING INFORMATION

	Ordering code
Tapered solid shaft with mounting support	0 548 011
Tapered hollow shaft	on request



- Provide accurate, absolute position feedback
- Rugged and able to withstand high shock and vibration levels
- Impervious to most industrial contaminant and temperature extremes
- High temperature up to 220°C
- Operation in non electroconductive liquids possible
- Maintenance-free (brushless)
- Aging resistant (no electronic components)
- Low-priced

Application fields:

- Servo drives
- Medical technologie (sterilisable)
- Robots
- Gearless drives
- Military engineering

Brushless resolvers are the ideal rotor position indicators for the position feedback of brushless motors, robots or direct drives. They are robust, reliable and suitable for high operating temperatures until 155 °C and resistant to most process liquids, contaminations, radiation and EMC-Interferences as well as highly shock-proof and vibration-resistant. These resolvers deliver absolute position information and can be combined with low cost integrated circuits, to generate an up to 16 bit digital position-value or, to produce an emulated incremental encoder output signal, as well as direction and analogue speed-signals.

DIMENSIONAL DRAWINGS

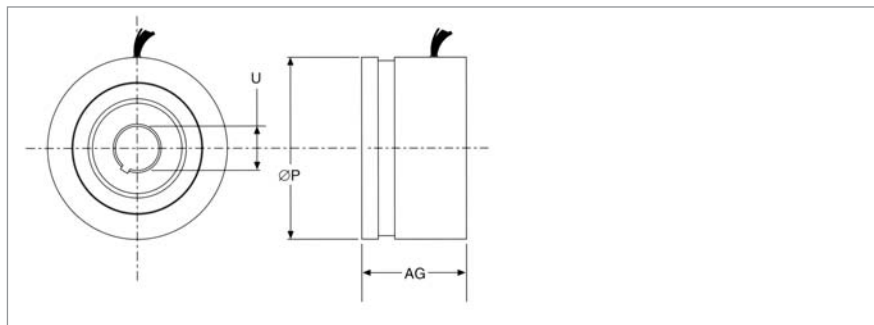

MODELLÜBERSICHT

Type (model)	AG	P	U maximal
10BRCX	16.5 mm	26.5 mm	6.0 mm
15BRCX	25.4 mm	36.8 mm	12.0 mm
21BRCX	31.8 mm	52.4 mm	20.3 mm
31BRCX	31.8 mm	77.5 mm	40.0 mm
55BRCX	31.8 mm	139.7 mm	92.7 mm

Ordering information:

Since resolvers are produced according to special applications, the production takes place only in big batch sizes. For replacement needs, please contact your drive-manufacturer.



DIMENSIONAL DRAWINGS

HOUSED RESOLVERS SERIES R 11

- Brushless construction
- Maintenance free
- Able to withstand high shock and vibration levels
- Impervious to most industrial contaminant and temperature extremes
- High temperature up to 115°C

Housed Resolvers distinguish themselves through high reliability in harsh environments, operating temperatures up to 155 °C and high shock resistance. Based on their brushless design they are the ideal supplement to brushless servo motors. The accuracy as well as the repeatability are excellent. These resolvers are equipped with precision bearings and are maintenance-free. They are also the shortest resolvers, that are available on the market.

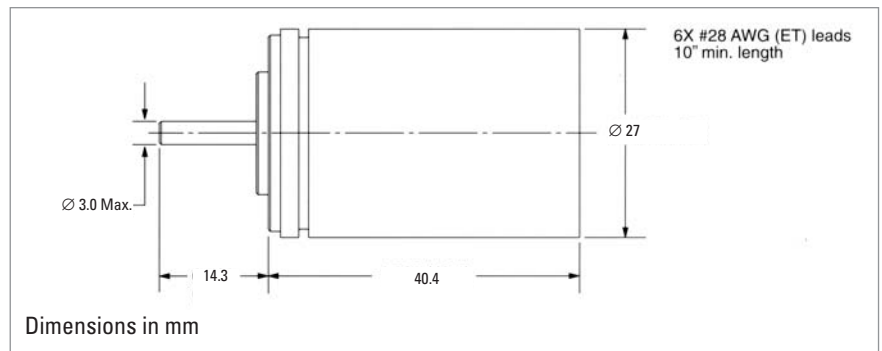

DIMENSIONAL DRAWINGS

HOUSED INDUSTRY RESOLVERS SERIES R 25

- Rugged housing with IP65
- Able to withstand high shock and vibration levels
- Impervious to most industrial contaminant and temperature extremes
- High temperature up to 125°C
- Flange- and servo-mount styles

Industry resolvers possess especially robust casings with protection class IP65. They are especially suitable for the use with high temperatures (+125 °C in long-term operation), and offer extraordinary values of vibration and shock resistance (40g as well as 200g), as well as noise immunity. The user is flexible in the application because of the corrosion resistant versions for integration or extension, the connection could easily be done by Standard MS-style connectors. The accuracy has a spread of ± 7 up to ± 200 arc-minutes.

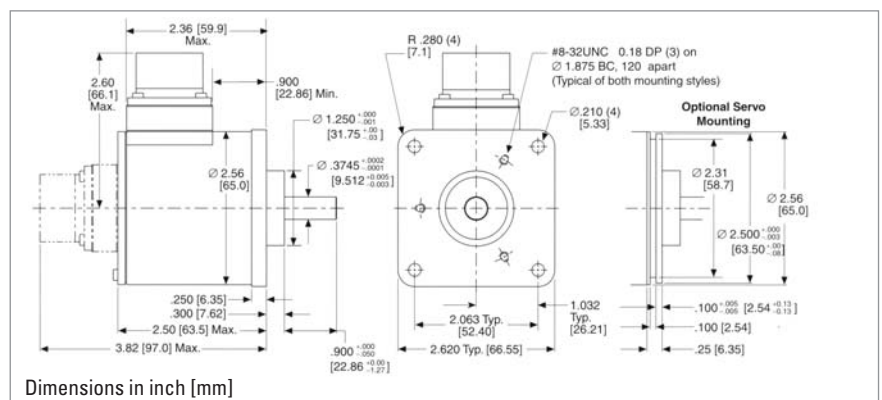

Accessories

Problem solutions from a single source.

Our wide range of accessory modules completes the encoder programme.

With these modules, we offer you an optimum means of meeting your application demands.

Position indicator signo 727 SSI

for absolute encoder connection



- Large, 6-digit, 14 mm high LED display
- Predetermined offset
- 2 variable limit values
- Easy direct selection by 2 function keys
- Relay outputs with change-over contacts
- Chain value or absolute value indication
- npn/pnp programming of inputs
- Synchronous Serial Interface

APPLICATION FIELDS

Indication of infeed values, lengths, support- or machine positions, totalizing values etc. The coupling to the machine may be done with an absolute encoder with SSI-Interface from the wide and comprehensive Hengstler program of types AC 58.

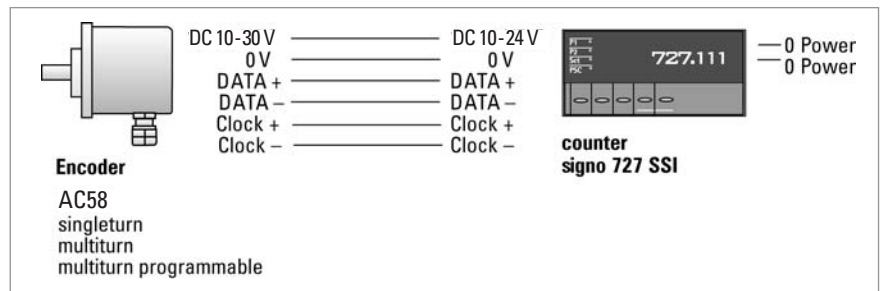

DISPLAY



- Section A:** shows the actual count value when in counting mode, and the changeable parameters when in programming mode.
- Section B:** LED indicators showing the active output signal, and in programming mode indicating the changeable parameter.

PROGRAMMING

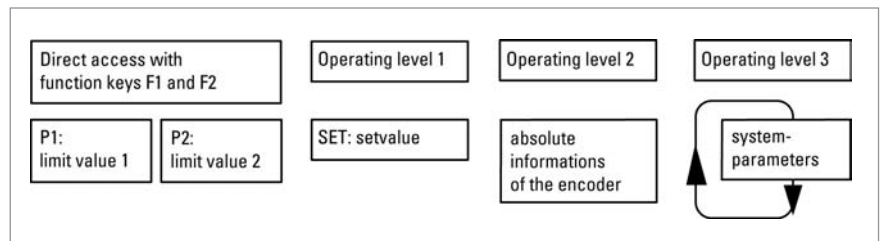

Programming of signo 727 is possible by direct access and in the 3 operating levels

- Direct access:** Limit values are set with the function keys F1, F2
- Operating level 1:** Set value
- Operating level 2:** Includes absolute informations of the encoder
- Operating level 3:** Includes system parameters, which are normally programmed during start-up procedure only.

Unauthorized programming of the signo 727 is prevented by a control input, which can lock the operating levels.

for absolute encoder connection

TECHNICAL DATA

Display	LED, indication value/preselection 6 digits, suppression of leading zeros, programmable decimal point, minus sign
Digit Height	14 mm
Power Supply Voltage U_B	DC 12 ... 24 V or AC 115/230 V, depending on version
Max. current w/o load	DC 12 ... 24 V < 250 mA, AC 115/230 V < 60 mA
Sensor Supply	AC operation DC 12...24 V, DC operation $U_B - 2 V$, $I_{max} = 60 mA$
Data Retention	non-volatile memory > 10 years
Operating Temperature	0 ... 50° C
Storage Temperature	-20 ... +70° C
Electrical Connection	plug-in terminals
Mounting	with clamping frame
Protection Class (IEC 144)	front side IP54, terminals IP20
Noise Immunity EMC	severity 3 according to IEC 801, part 2 + part 4
Vibration resistance	10 m/s ² (10 ... 150 Hz) according to IEC 68-part 2-6
Shock resistance	100 m/s ² (18 ms) according to IEC 68-part 2-27
General design	according to VDE 0411, DIN 57411, protection class II
Inputs	SSI Data + SSI Data -
Baud rate	approx. 100 kHz
Control Input	Application Input 1, static Display hold, Reset or Chain Reset (programmable)
Keylock	static
Outputs	SSI measure + SSI measure -
Relay ¹	Out 1 and Out 2
Contact Type	changeover relay
Switching Voltage	max. 250 VAC/30 VDC, mind 5 VAC/DC
Switching Current	max. 1A, min. 10 mA

¹ for versions with limit values only

Position indicator signo 727 SSI for absolute encoder connection

DIMENSIONAL DRAWINGS

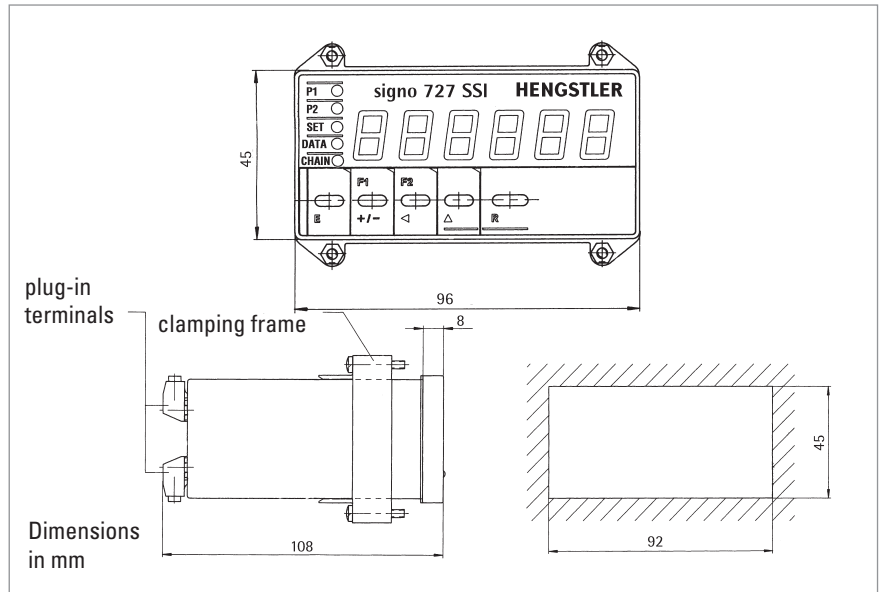

CONNECTION PLAN

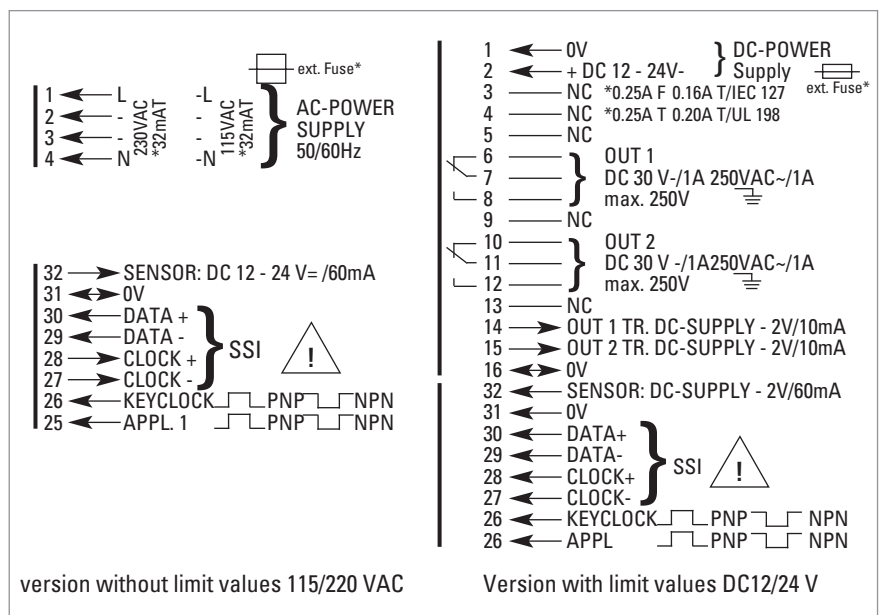

ORDERING DATA

Type	Absolute encoder connection	Supply	Ordering code
signo 727 without limit values	SSI	DC 12 - 24 V	0 727 111
signo 727 without limit values	SSI	AC 115/230 V	0 727 112
signo 727 with 2 limit values	SSI	DC 12 - 24 V	0 727 131
signo 727 with 2 limit values	SSI	AC 115/230 V	0 727 132

opt. with interface RS 485, RS 232 on request

Please note:

Absolute encoders with capped Gray Code (e.g. 360 or 720) must not be connected
 Max. encoder resolution: 12 Bit ST (singleturn) and 24 Bit MT (multiturn 12 + 12 Bit)

Encoder with Shock Module

AC58-S/M/P WITH OPTIONAL SHOCK MODULE

Applications with vibration rates of up to $>100 \text{ m/s}^2$ and shock rates $>1000 \text{ m/s}^2$ require the use of a shock module. By means of integrated attenuating elements, these encoder ratings are reduced.

Fixing	flange by means of clamping flange or clamping eccentric, shaft by means of flexible coupling
Absolute max. shaft load	axial 30 N, radial 100 N
Shaft diameter	10 mm

DIMENSIONAL DRAWING Encoder with shock module, connecting cable

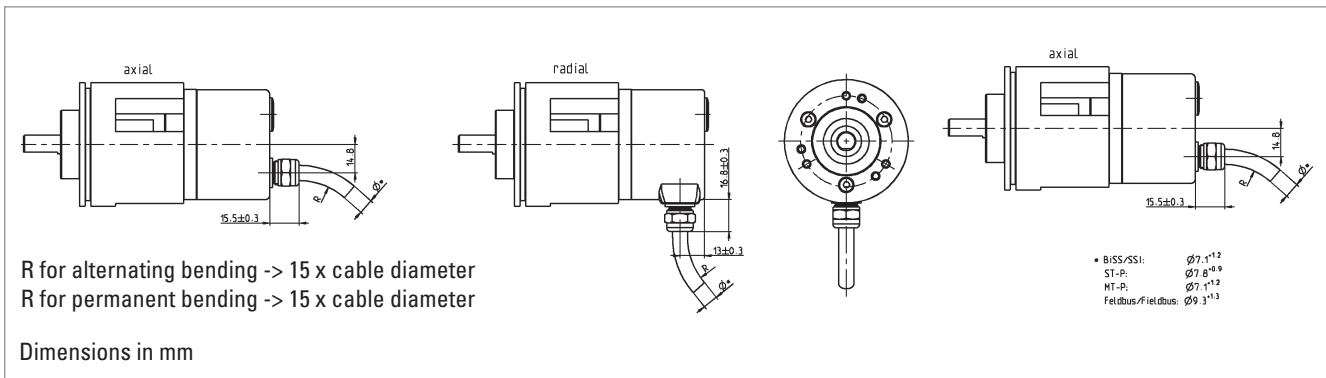

DIMENSIONAL DRAWING Encoder with shock module, flange connector

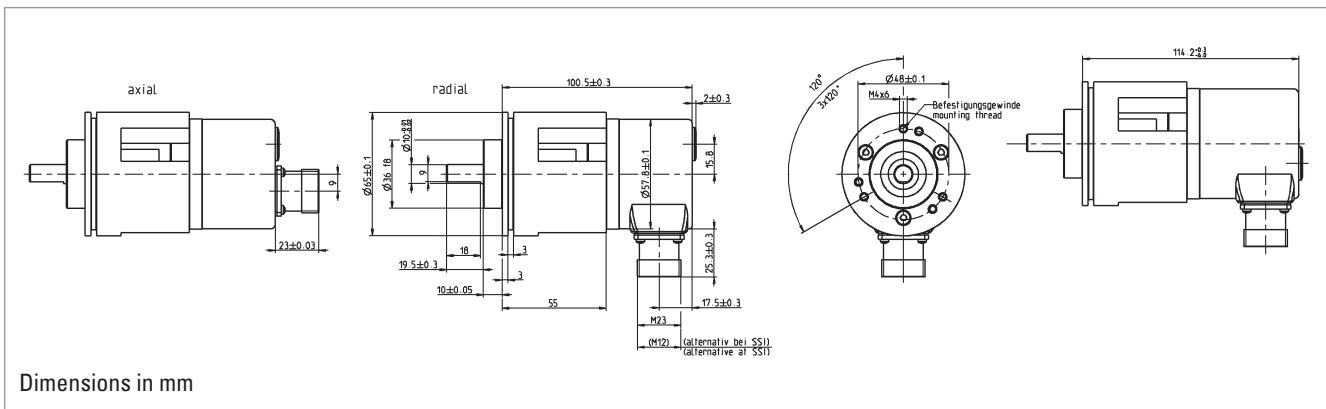

ORDERING DATA

For the encoder option with shock module, please enquire by stating your desired encoder type.

(Accessories unit 1 540 239
Flange ordering code: L.42 for RI 58, K.42 for AC 58)

Flexible Couplings

Shaft encoders must be protected against excessive mechanical stresses, which occur whenever there are angular, axial, or radial misalignments between the machine and shaft encoder shafts.

Our flexible couplings can compensate for this within limits.



PLASTIC COUPLING

Max. speed	10 000 min ⁻¹
Torque max.	20 Ncm
Moment of inertia	1.1 gcm ²
Torsional spring constant	12 Nm/rad
Max. angular misalignment	±2.5°
Max. shaft misalignment radial / axial	±0.3 mm / ±0.2 mm
Max tightening torque of set screws	70 Ncm
Material	polyamide 6.6 glass-fibre reinforced
Weight approx.	6 g

Plastic coupling

Closed-form hub connection

Set screw M3 x 4
DIN 916

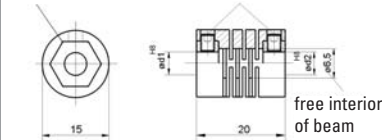

Dimensions in mm

Hub diameter

5/5 mm

Ordering code **3 520 034**

5/6 mm

Ordering code **3 520 033**

6/6 mm

Ordering code **1 761 026**

Suitable for encoder type RI 39

RI 32, RI 41, RI 42 for simple applications



HELICAL COUPLING

Max. speed	6 000 min ⁻¹
Torque max.	80 Ncm
Moment of inertia	8.7 gcm ²
Torsional spring constant	14 Ncm/degree
Max. angular misalignment	±4°
Max. shaft misalignment radial/axial	±0.25 mm / ±0.4 mm
Max tightening torque of set screws	80 Ncm
Material	AlCuMgPb, chromed
Weight	16 g

Helical coupling 19/28

Cylinder screws M3 x 10
DIN 916

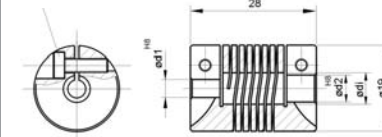

Dimensions in mm

Helical coupling 25/32

Cylinder screws M3 x 10
DIN 916

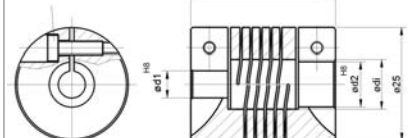

Dimensions in mm

Hub diameter

5/5 mm

Ordering code **3 520 036**

5/6 mm

Ordering code **3 520 035**

6/6 mm

Ordering code **0 070 653**

6/6.35 mm

Ordering code **3 520 051**

6.35/6.35 mm

Ordering code **3 520 057**

Suitable for encoder type RI 30, RI 32,
RI 36, RI 41, RI 42, RI 58, AC 58

Hub diameter

6/9.53 mm

Ordering code **3 520 052**

6/10 mm

Ordering code **3 520 066**

6.35/9.52 mm

Ordering code **3 520 062**

10/12 mm

Ordering code **3 520 065**

10/10 mm

Ordering code **3 520 074**

Suitable for encoder type RI 58, AC 58

Flexible Couplings



ISOLATED DISK COUPLING

Max. speed		12 000 min ⁻¹
Torque max.		60 Ncm
Max. shaft misalignment	radial	±0.3 mm
	axial	±0.4 mm
	angular	±2.5°
Torsional spring constant		30 Nm/rad
Material	Flanges	aluminium, anodized
	Spring disc	plastic, glass-fibre reinforced

Hub diameter

5/6 mm	Ordering code 3 520 080	Suitable for encoder type RI 30, RI 32, RI 36, RI 41, RI 42, RI 58, AC 58
6/6 mm	Ordering code 3 520 081	
6/10 mm	Ordering code 3 520 082	
6/6.35 mm	Ordering code 3 520 083	
6/9.53 mm	Ordering code 3 520 084	
6.35/6.35 mm	Ordering code 3 520 085	
7/7 mm	Ordering code 3 520 086	
10/6.35 mm	Ordering code 3 520 087	
10/10 mm	Ordering code 3 520 088	



DISK COUPLING

Max. speed		12 000 min ⁻¹
Torque max.		80 Ncm
Moment of inertia		19 gcm ²
Torsional spring constant		150 Nm/rad
Max. angular misalignment		±3.0°
Max. shaft misalignment	radial	±0.4 mm
	axial	±0.4 mm
Max tightening torque of set screws		80 Ncm
Hub diameter d and d ₁		6 mm H 8
Material	coupling body, flange	AlCuMgPb, anodized
	preloaded disc	stainless steel
Weight approx.		14.5 g

Ordering code **0 070 663** suitable for encoder type RI 36, RI 58, AC 58

DIMENSIONAL DRAWINGS

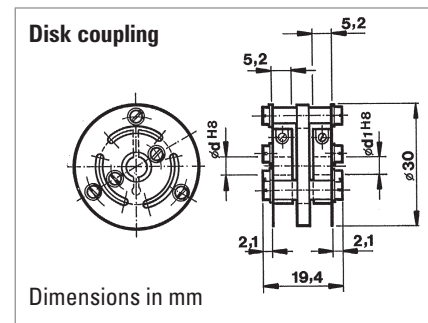
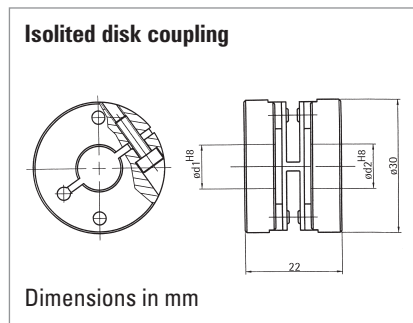

Flexible Couplings



BELLOWS COUPLING

Max. speed		8000 min ⁻¹
Torque max.		80 Ncm
Moment of inertia		9 gcm ²
Torsional spring constant		140 Nm/rad
Max. angular misalignment		±4.0°
Max. shaft misalignment	radial	±0.3 mm
	axial	±0.5 mm
Max tightening torque of set screws		150 Ncm
Material	flange	aluminium
	bellows	stainless steel
Weight		16 g

Hub diameter

12/12 mm

Ordering code **0 070 666**

Suitable for type RI 58, AC 58

10/10 mm

Ordering code **3 520 037**

9.53/9.53 mm

Ordering code **3 520 038**

6/6 mm

Ordering code **3 520 068**

DIMENSIONAL DRAWING

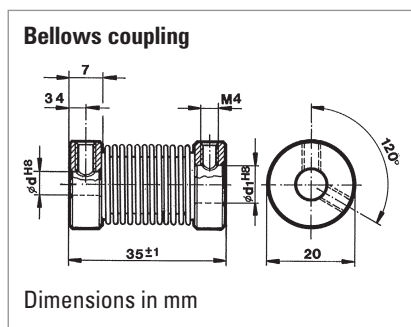

Mounting

CLAMPING ECCENTRIC

Material CuZn39Pb3, surface nickel-plated

Set of three

Suitable for encoders with synchro flange type RI 30, RI 36, RI 58, AC 58

	$\varnothing d_1$	$\varnothing d_2$	$\varnothing d_3$	a	b	c
Ordering code 0 070 655 (RI 58, AC 58 Synchro flange for M3)	$8.9_{+0.1}$	6.5	3.2	$4.9_{-0.1}$	$2.9_{0.1}$	1.2
Ordering code 0 070 657 (RI 58, AC 58 Synchro flange for M3)	12	9	3.5	$4.9_{-0.1}$	$2.9_{0.1}$	1.5
Ordering code 0 070 654 (RI 30, RI 36 Synchro flange for M2.5)	$6.8_{+0.2}$	5	2.8	$4.4_{-0.1}$	$2.4_{0.1}$	0.9

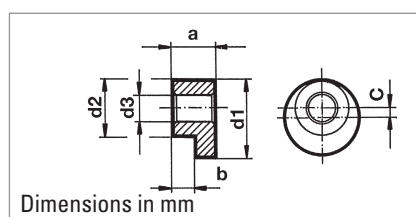

Types for M4 on request

SQUARE FLANGE ADAPTER 80 x 80 mm for clamping flange RI 58, AC 58 (fastening material included)

Ordering code 1 522 327

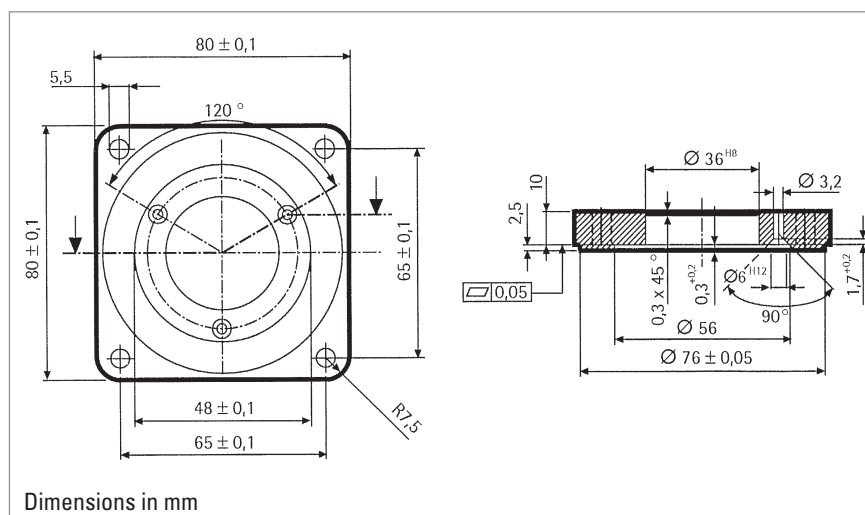

SQUARE FLANGE ADAPTER 58 x 58 mm for clamping flange RI 58, AC 58 (fastening material included)

Ordering code 1 522 326

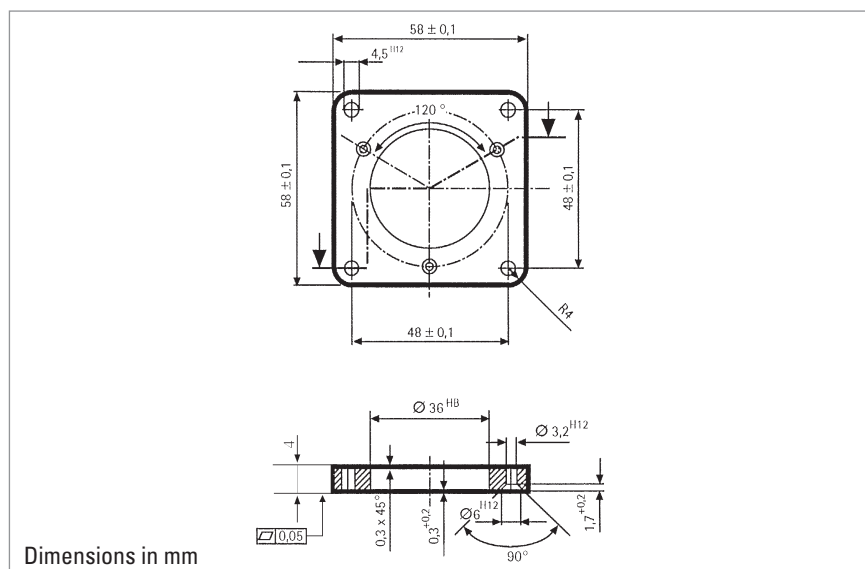

Mounting

SYNCHRO FLANGE ADAPTER
for clamping flange RI 58, AC 58
(fastening material included)

Ordering code 1 522 328

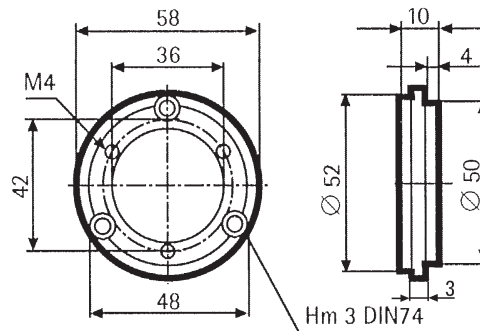

Dimensions in mm

SYNCHRO FLANGE ADAPTER
for clamping flange RI 58
(same dimensions as TR HE 65)
(fastening material included)

Ordering code 1 522 542

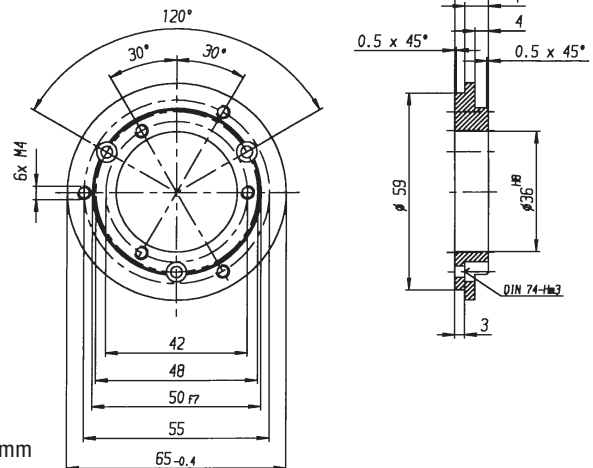

Dimensions in mm

SYNCHRO FLANGE ADAPTER
for clamping flange RI 58
(same dimensions as AG 661)
(fastening material included)

Ordering code 1 522 547

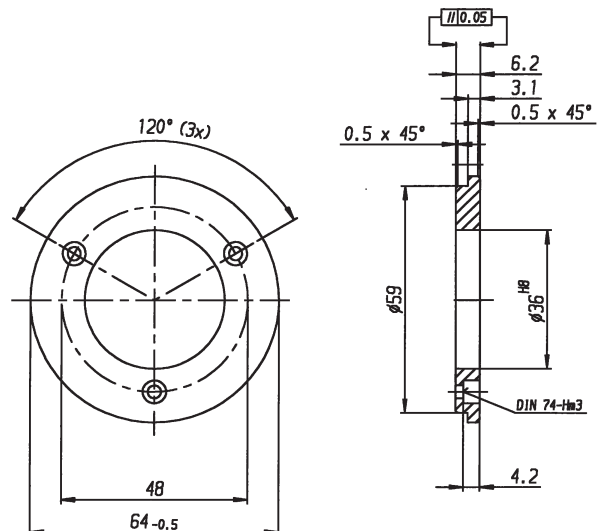

Dimensions in mm

Mounting

MOUNTING BELL (PLASTIC)
for synchro flange RI 58, AC 58
(clamping eccentric and
fastening material included)

Ordering code 1 522 330

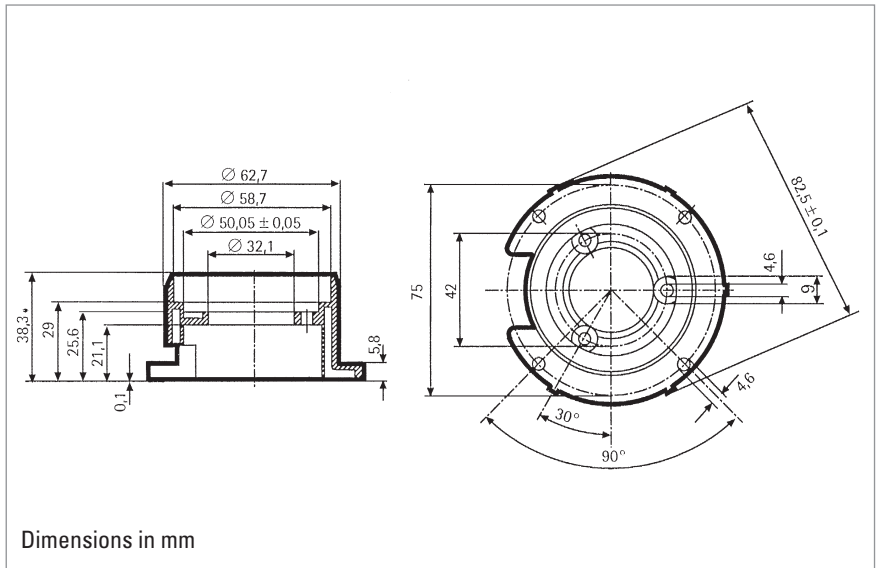

Connectors

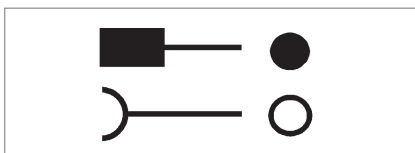
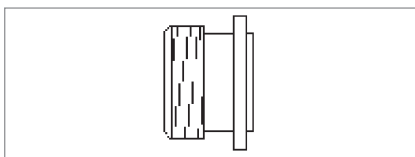
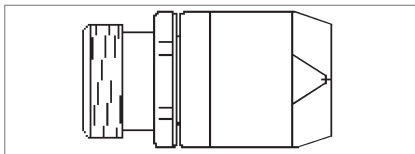
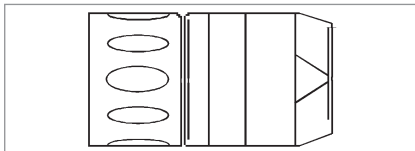
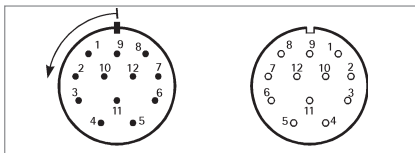
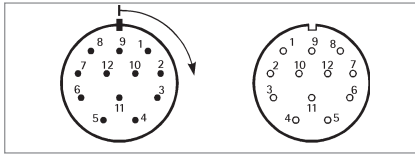

NUMBERING OF PINS

Clockwise system:

A connector with pin contacts, which is numbered clockwise, and the corresponding counter-plug connector with socket contacts (which consequently must be numbered counter-clockwise), is called right-turning.

Counter clockwise system:

A connector with pin contacts, which is numbered counter clockwise, and the corresponding counter-plug connector with socket contacts (which consequently must be numbered clockwise), is called left-turning.

PLUG

A connector with coupling nut is called plug, without regard to its pin or socket contacts.

COUPLING

A connector with outer thread is called coupling without regard to its pin or socket contacts.

CONNECTOR

A connector is fastened to the encoder or the machine's housing, has an outer thread (like the coupling) and is available with pin or socket contacts.

CONTACTS

Sign for pin contact

Sign for socket contact

Connectors

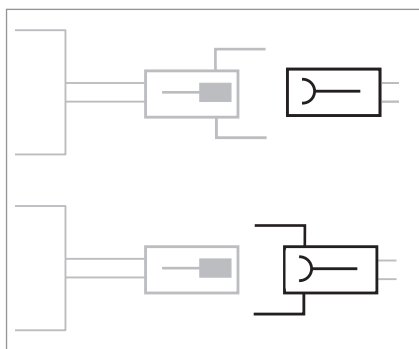
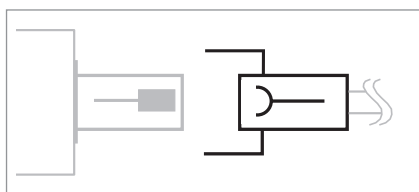
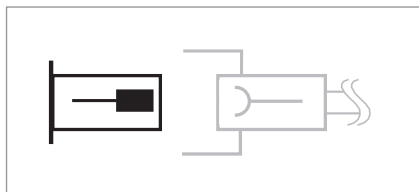

CONNECTOR FOR MOUNTING IN ENCODER HOUSING (IDENTICAL WITH ENCODER CONNECTOR CONIN 12 POLE)

Connector (pins)	Ordering code
CONIN 12 pole, clockwise	3 539 198
CONIN 12 pole, counter clockwise	3 539 230

CONNECTOR MATCHING WITH ENCODER CONNECTOR ¹

Encoder connector (pins)	Suitable plug (socket)
Conin 12 pole, clockwise (C, D)	3 539 202 (PG 9)
Conin 12 pole, counter clockwise (G, H)	3 539 229 (PG 9)
Conin 17 pole, counter clockwise (U, V)	3 539 256
Conin 17 pole, clockwise (W, Y)	3 539 254
Conin 21 pole, clockwise	1 540 232
Binder 6 pole (J, N)	3 539 472 (straight, IP67) 3 539 209 (bent, IP40)
MIL 6 pole (M, Q)	3 539 261
MIL 7 pole (L, P)	3 539 262
MIL 10 pole (K, O, R, T)	3 539 258
KPT 12-8P (1, 2)	3 539 333

¹ Extension cables with plug refer to "Extension Cables"

CONNECTOR MATCHING WITH ENCODER CABLE WITH CONNECTOR

Encoder plug (pins)	Suitable coupling (socket)
Conin 12 pole, clockwise (-C) (3 539 186)	3 539 187
VDW ¹ , 12 pole, clockwise (-B) (3 539 252)	3 539 304
SUB-D, 37 pole, (-F) (1 542 025)	1 542 024
Encoder coupling (pins)	Suitable plug (socket)
Conin 12 pole, counter clockwise (-D) (3 539 273)	3 539 229
VDW ¹ , 12 pole, counter clockwise (-E) (3 539 274)	3 539 305

¹ VDW corresponding to Conin plastic-coated

Connectors

CONNECTOR ON CONNECTING CABLE SUITABLE FOR DOWNSTREAM LOGIC CIRCUIT

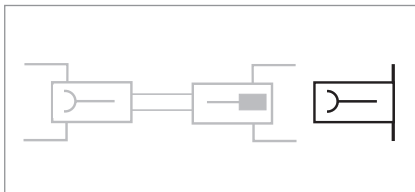
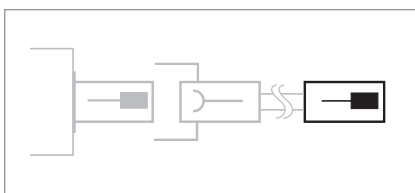
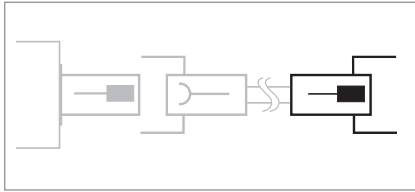

Plug (pins)	Ordering code
Conin 12 pole, clockwise	3 539 186
Conin 12 pole, counter clockwise	3 539 316
Conin 9 pole, clockwise	3 539 293
VDW ¹ 12 pole, clockwise	3 539 252
Conin 17 pole, clockwise	3 539 317
Conin 17 pole, counter clockwise	3 539 309

Coupling (pins)	Ordering code
Conin 12 pole, clockwise	3 539 301
Conin 12 pole, counter clockwise	3 539 273
VDW ¹ 12 pole, counter clockwise	3 539 274
Conin 17 pole, clockwise	3 539 302
Conin 17 pole, counter clockwise	3 539 303

¹ VDW corresponding to Conin plastic-coated

CONNECTOR FOR MOUNTING INTO DOWNSTREAM LOGIC CIRCUIT HOUSING

Connector (socket)	Ordering code
Conin 12 pole, clockwise	3 539 318
Conin 12 pole, counter clockwise	3 539 319

MOUNTING ACCESSORIES

Mounting spanner for Conin connectors	Ordering code
	3 539 343

OTHER CONNECTORS

Conin plug 9 pole clockwise, socket	Ordering code
	3 539 294
Binder 6 pole	3 539 472

Extension cables

EXTENSION CABLES with plug (socket) on one end

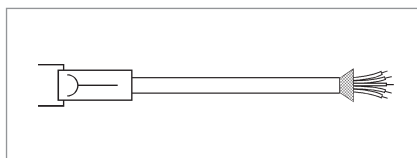

CONIN 12 POLE FOR RI 58 (TPE CABLE)

Pin	Colour ¹	Lead mm ²
1	pink	0.14
2	blue	0.14
3	red	0.14
4	black	0.14
5	brown	0.14
6	green	0.14
7	violet	0.14
8	grey	0.14
9	Screen	0.14
10	white/green	0.5
11	white	0.14
12	brown/green	0.5
Housing	Screen	

¹ Cable version 3 280 112

BINDER 6 POLE FOR RI 30, RI 36, RI 58 (PVC CABLE)

Pin	Colour ¹	Lead mm ²
1	red	0.5
2	white	0.14
3	yellow	0.14
4	green	0.14
5	yellow/black	0.14
6	black	0.5
Housing	Screen	

¹ Cable version 3 280 113

CONIN 12 POLE FOR AC 58 WITH SSI-INTERFACE (TPE CABLE)

Pin	Colour ¹	Lead mm ²
1	brown	0.5
2	pink	0.14
3	yellow	0.14
4		
5	blue	0.14
6		
7		
8	white	0.5
9		
10	grey	0.14
11	green	0.14
12	black	0.14
Housing	Screen	

¹ Cable version 3 280 220

EXTENSION CABLE WITH 8 POLE M12 PLUG FOR AC 58

Length	Ordering code
3 m	1 565 329
5 m	1 565 330
10	1 565 331

Length	Matching with C/D, cw ¹	Matching with G/H, ccw ²
	Ordering code	Ordering code
3 m	1 522 348	1 522 394
5 m	1 522 349	1 522 395
10 m	1 522 350	1 522 396
15 m	1 522 454	1 522 447
20 m	1 522 456	1 522 461
25 m	1 522 457	1 522 462
30 m	1 522 464	1 522 463

¹ matching with encoder connector 12 pole, cw (C/D)

² matching with encoder connector 12 pole, ccw (G/H)

Length	Ordering code
3 m	1 522 405
5 m	1 522 404
10 m	1 522 340

matching with encoder connector (BINDER) 6 pole (J, N)

Length	Matching with C/D, cw ¹	Matching with G/H, ccw ²
	Ordering code	Ordering code
3 m	1 542 003	1 542 010
5 m	1 542 004	1 542 011
10 m	1 542 005	1 542 012
15 m	1 542 006	1 542 013
20 m	1 542 007	1 542 014
25 m	1 542 008	1 542 015
30 m	1 542 009	1 542 016
40 m	1 542 026	1 542 028
50 m	1 542 027	1 542 029

¹ matching with encoder connector 12 pole, cw (C/D)

² matching with encoder connector 12 pole, ccw (G/H)

Extension cables

EXTENSION CABLES with plug (socket) on one end

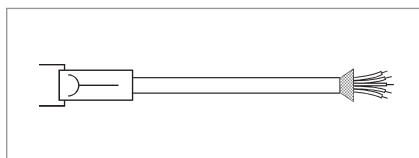

MIL 10 POLE FOR RI 58 (TPE CABLE)

Pin	Colour ¹	Lead mm ²
A	brown	0.14
B	grey	0.14
C	red	0.14
D	brown/green	0.5
E	violet	0.14
F	white/green	0.5
G	green	0.14
H	pink	0.14
I	black	0.14
J	Screen	0.14

Length	Ordering code
3 m	1 522 610

¹ Cable version 3 280 112

CONIN 12 POLE FOR AC 58 WITH SSI-P INTERFACE (TPE CABLE)

Pin	Colour ¹	Lead mm ²
1	green	0.14
2	yellow	0.14
3	pink	0.14
4	grey	0.14
5	brown	0.14
6	white	0.14
7	black	0.14
8	blue	0.14
9	red	0.14
10	violet	0.14
11	white	0.5
12	brown	0.5
Housing	Screen	

Length	Ordering code
3 m	1 543 002
5 m	1 543 003
10 m	1 543 004
15 m	1 543 005
20 m	1 543 006
25 m	1 543 007
30 m	1 543 008
40 m	1 543 015
50 m	1 543 016

¹ matching with encoder connector
12 pole, ccw (G/H)

¹ Cable version 3 280 220

SUB-D 37 POLE FOR AC58 WITH PARALLEL INTERFACE (TPE CABLE)

Colour ¹	Pin	Colour ¹	Pin
brown	2	white/blue	14
green	21	brown/blue	33
yellow	3	white/red	15
grey	22	brown/red	34
pink	4	white/black	16
violet	23	brown/black	35
grey/pink	5	grey/green	17
red/blue	24	yellow/grey	36

Colour ¹	Pin	Colour ¹	Pin
white/green	6	pink/green	18
brown/green	25	yellow/pink	10
white/yellow	7	green/blue	30
yellow/brown	26	yellow/blue	12
white/grey	8	red	13
grey/brown	27	white	31
white/pink	9	blue	1
pink/brown	28	black	20

¹ Cable version 3 280 221

Length	Ordering code
1 m	1 542 163
3 m	1 542 020
5 m	1 542 021
10 m	1 542 022
15 m	1 542 172

Length	Ordering code
20 m	1 542 173
25 m	1 542 174
30 m	1 542 175
40 m	1 542 176
50 m	1 542 177

Extension cables

CONIN 17 POLE FOR AC 58 WITH PARALLEL INTERFACE (PVC CABLE)

Pin	Colour ¹	Lead mm ²
1	brown/grey	0.14
2	red/blue	0.14
3	violet	0.14
4	white/brown	0.14
5	white/green	0.14
6	white/yellow	0.14
7	white/grey	0.14
8	white/pink	0.14
9	white/blue	0.14
10	white/red	0.14
11	white/black	0.14
12	brown/green	0.14
13	pink	0.14
14	green	0.14
15	black	0.5
16	red	0.5
17	brown	0.14
Housing	Screen	

Length	Matching with W/Y, cw ¹	Matching with U/V, ccw ²
	Ordering code	Ordering code
3 m	1 540 100	1 540 097
5 m	1 540 101	1 540 098
10 m	1 540 102	1 540 099
15 m	1 540 142	1 540 138
20 m	1 540 143	1 540 139
25 m	1 540 144	1 540 140
30 m	1 540 145	1 540 141
40 m	1 540 205	1 540 207
50 m	1 540 206	1 540 208

¹ matching with encoder connector
17 pole, cw (W/Y)

² matching with encoder connector
17 pole, ccw (U/V)

Connection diagram see AC 58,
parallel interface with connector.

¹ Cable version 3 280 100

EXTENSION CABLES WITH CONNECTOR ON BOTH ENDS

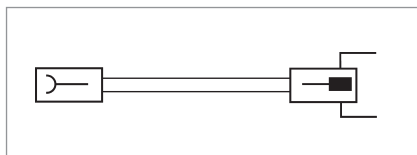

CONIN 12 POLE FOR AC58 WITH INTERBUS-INTERFACE (TPE CABLE)

Length ¹	clockwise Ordering code
3 m	1 542 017
5 m	1 542 018
10 m	1 542 019

¹ Cable version 3 280 220

CABLE NOT MADE UP WITH CONNECTORS

	Ordering code
TPE cable for RI (12-core + screen)	3 280 112 + length
PVC cable for RI (10-core + screen)	3 280 114 + length
PVC cable for RI (6-core + screen)	3 280 113 + length
PVC cable for AC58 mit Parallel (20-core + screen)	3 280 100 + length
TPE cable for AC58 mit SSI od. IB-S (12-core + screen)	3 280 220 + length
TPE cable for AC58 mit Parallel (32-core + screen)	3 280 221 + length

Measuring Wheels

GENERAL ASPECTS



In order to prevent the result being distorted when the shaft encoder is driven by a measuring wheel make sure that the slip is as small as possible. When selecting the tread (surface), take into account the structure, stretchability, thickness, and resistance to being carried along of the material being measured.

The slip is also affected by the width of the measuring wheel, the contact pressure, the tension in the material being measured, and the arc of contact. The arc of contact should be as large as possible. The wheel bodies are made of cast aluminium or plastic (as marked).

The position of the measuring wheel should be chosen so that the direction of movement of the material is away from the shaft encoder's bearing point.

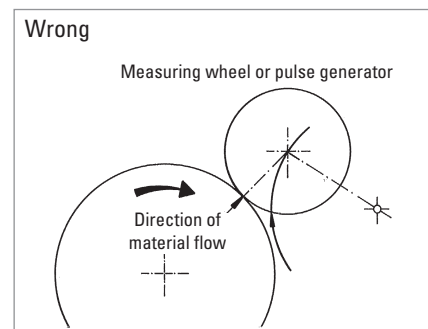
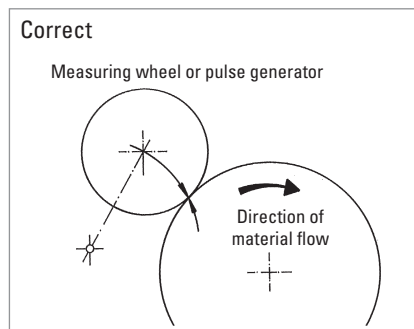

MEASURING WHEEL TREADS

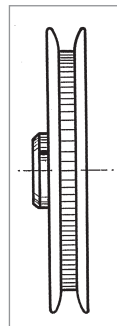

Tread 1
with rim and
fine crosshatched knurl
Material: aluminium

Applications such as
threads and yarns

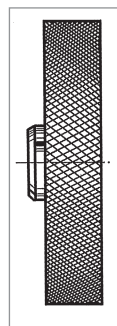

Tread 2
with glued-on rubber profile
A = soft specially clinging rubber
surface (red)
B = low-wear rubber surface with
good grip (white)

Applications such as
paper and cardboard, measuring
cables, nongreasy metals, fleece,
undressed or surface-treated
wood, soft and hard plastics.

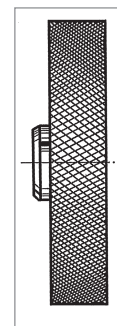

Tread 3
vulcanized rubber
surface with parallel
knurl

Applications such as
rubber, leather, fabrics,
flooring and glass.

Messräder

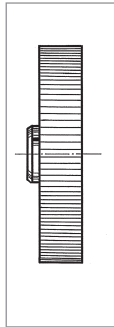

Tread 4

aluminium with parallel knurl

Applications such as rubber, soft plastics, wood with rough surface, and to a limited extent for fabrics.

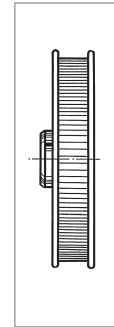

Tread 5

with rim, aluminium with parallel knurl

Applications such as threads, yarns, and bands.

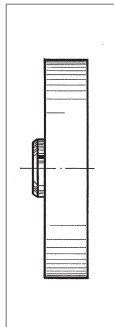

Tread 6

plastic surface

Applications such as wire, greasy metals, and steel sections.

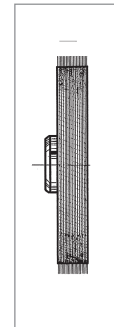

Tread 7

carding belt

Applications such as carpets and coarse fabrics.

ORDERING DATA

Aluminium

Diameter	Circumference	Tread	Width of bearing surface mm	Bore diameter			
				4.0 mm	6.0 mm	7.0 mm	10.0 mm
6.37 cm	0.2 m	1	4	0 601 014	0 601 015	0 601 017	—
		2 A	12	0 601 018	—	—	—
		2 B	12	0 601 118	0 601 048	—	0 601 049
		2 A	24	0 601 020	—	0 601 092	—
		2 B	24	—	—	0 601 192	—
		4	20.5	0 601 023	—	—	—
		4	20	—	—	0 601 093	—
		5	16.5	0 601 026	—	0 601 094	—
15.92 cm	0.5 m	2 A	25	—	—	0 601 050	—
		2 B	25	—	—	0 601 150	0 601 151
		3	25	—	—	0 601 059	0 601 156
		4	25	—	—	0 601 121 ¹	0 601 157
		5	16	—	—	—	—
		6	25	—	—	0 601 063 ¹	0 601 163
		7	26.5	—	—	—	—
5.73 cm	1/5 yd.	1	4	0 601 034	—	0 601 037	—
		2 A	24	0 601 042	—	0 601 095	—
		5	16.5	—	—	0 601 096	—
14.33 cm	1/2 yd.	2 A	25	—	—	—	—
		4	25	—	—	0 601 061	—
9.70 cm	1 foot	2 A	25	—	—	0 601 071	—
		2 B	25	—	—	0 601 171	—
		4	25	—	—	0 601 070	—

Plastic

6.37 cm	0.2 m	1	4	0 601 100	—	—	—
15.92 cm	0.5 m	4	25	—	—	0 601 301	—
		6	25	—	—	0 601 300	—

¹ PTB approved

Other measuring wheels available on request

Encoder Basics

GENERAL INFORMATION

Incremental encoders are sensors capable of generating signals in response to **rotary movement**. In conjunction with mechanical conversion devices, such as rack-and-pinions, measuring wheels or spindles, incremental shaft encoders can also be used to measure **linear movement**. The shaft encoder generates a signal for each incremental change in position.

With the **optical transformation**, a line-coded disc made of metal, plastic or glass and positioned on a rotary bearing interrupts the infra red light ray emitted by gallium arsenid sender diode. The number of lines determines the resolution, i.e. the measuring points within a revolution. The interruptions of the light ray are sensed by the receptor element and electronically processed. The information is then made available as a rectangular signal at the encoder output.

Output Signals of Incremental Encoders

OUTPUT SIGNALS

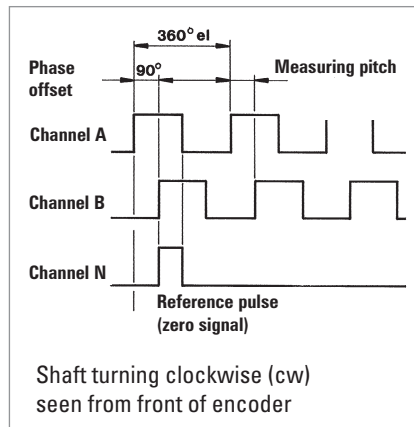

The shaft encoders supply two square wave pulses offset by 90° A and B, and a reference pulse N (zero signal) as well.

In order to suppress spurious pulses, certain output circuits (RS 422 and push-pull) generate inverted signals (\bar{A} , \bar{B} , \bar{N}), such as in models RI 30, RI 36, RI 58, RI 58-H, RI 76-TD and RI 58-D.

The measuring pitch is defined as the value of the distance between two pulse edges of A and B.

EVALUATION

The resolution of a two-channel shaft encoder can be doubled or quadrupled in the subsequent circuitry.

This enables the resolution of a two-channel encoder with 2500 lines per rev. to be increased electronically to 5,000 or 10,000 pulses per revolution (see diagram below).

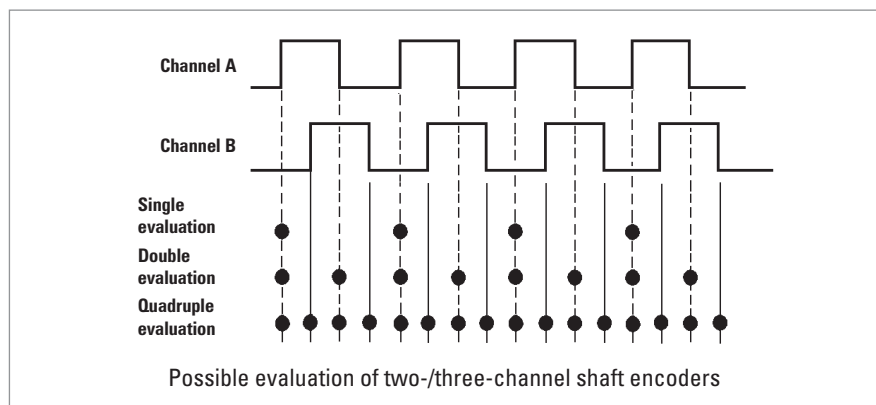

Encoder Basics

Maximum Speed, Protection Class

SPEED

The maximum permissible speed of a shaft encoder is derived from:

- the **mechanically permissible r.p.m.**,
- the minimum permissible **pulse-edge spacing** of the square-wave output signals of the shaft encoder for the subsequent circuitry, which depends on the tolerance of the phase offset,
- the **functional speed**, which is limited by the pulse frequency.

The mechanically permissible r.p.m. is specified for each shaft encoder among the mechanical characteristics.

In general, the control circuitry does not permit less than a certain **minimum edge spacing** between the square-wave output signal pulses. The minimum pulse-edge spacing is specified for each model of shaft encoder among the electrical characteristics.

The **functional speed** of an encoder is obtained by the equation:

$$n_{\max} = f_{\max} \cdot 10^3 \cdot 60 / Z$$

n_{\max} = maximum functional speed [r.p.m.]

f_{\max} = maximum pulse frequency of shaft encoder, or input frequency of downstream circuitry [kHz]

Z = number of pulses of shaft encoder

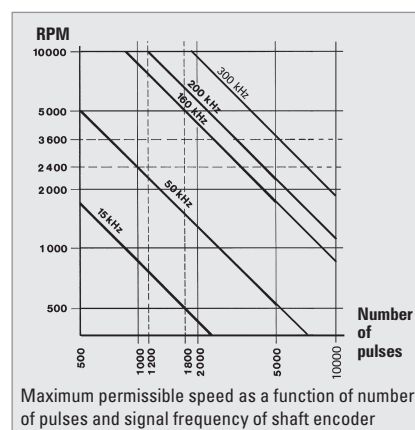

PROTECTION CLASS

All encoders of the industrial types RI 30, RI 36, RI 58, RI 58-H, RI 58-D, RA 70-I as well as the absolute encoders ACURO, comply with protection class IP65 according to EN 60529 and IEC 529, unless otherwise stated.

These specifications are valid for the housing and the cable output and also for plugged in socket connectors. The shaft input complies with protection class IP64. If however the encoder is mounted vertically, there must be no standing water present at the shaft input and the ball bearings.

In case the standard protection class IP64 is not sufficient for the shaft input, e.g. with vertical mounting of the encoder, the encoders must be protected by additional labyrinth or pot-type seals.

On request our encoders are also available with protection class IP67 for the shaft input and for the housing.

Encoder Basics

Examples of Flange Mounting

FLANGE TYPE OVERVIEW

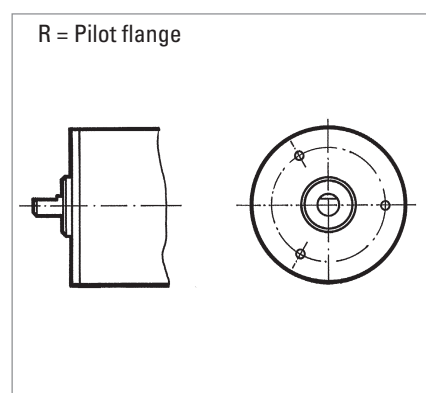
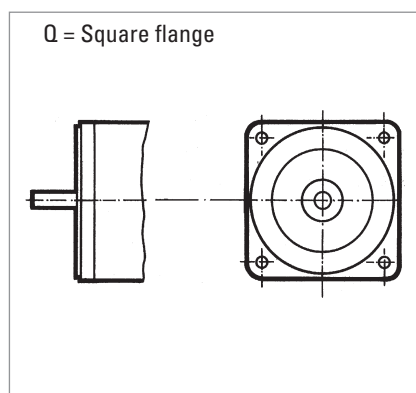
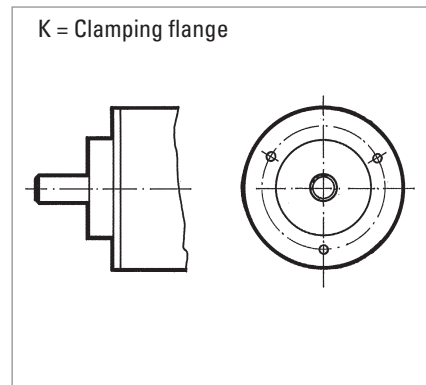
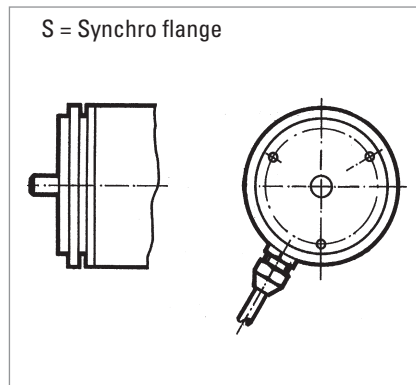

SHAFT ENCODERS WITH CLAMPING FLANGE

The shaft encoders with a clamping flange can be installed in following ways:

- by means of various flange adapters (see "Accessories"),
- by means of the clamping flange itself,
- by means of the fastening threads provided on the face,
- by means of an angle bracket (see "Accessories").

The encoder housing is centered by means of the clamping flange.

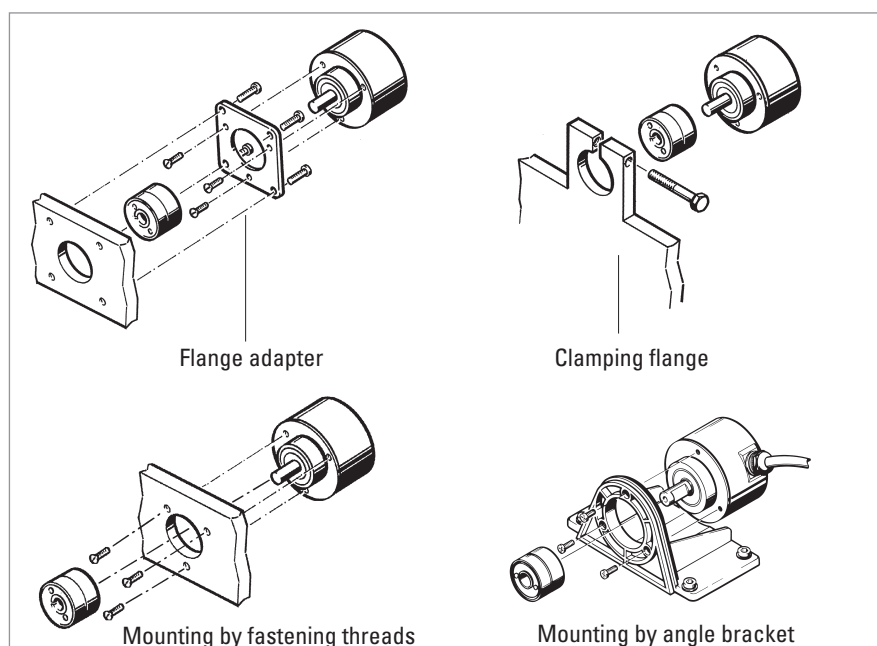

Encoder Basics

Examples of Flange Mounting

SHAFT ENCODERS WITH SYNCHRO FLANGE

The shaft encoders with synchro flange can be installed in two ways:

- by means of the synchro flange and three clamping eccentrics (see "Accessories"),
- by means of the fastening threads provided on the face.

The encoder is centered by means of the centering collar on the flange.

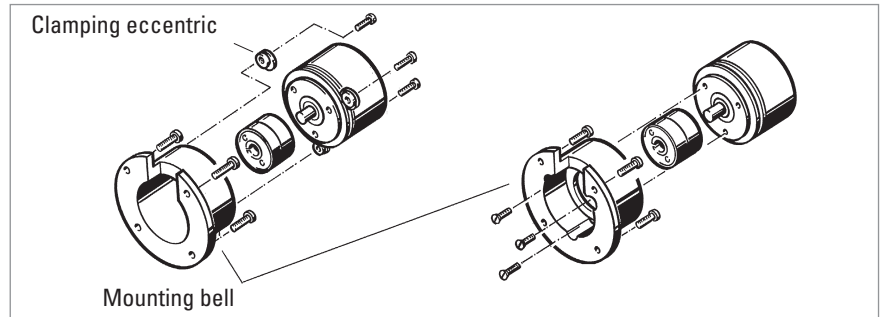

SHAFT ENCODERS WITH SQUARE FLANGE

The shaft encoders with square flange can be installed in two ways:

- by means of the fastening threads provided on the face,
- by means of an angle bracket.

The encoder is centered by means of the centering collar on the flange.

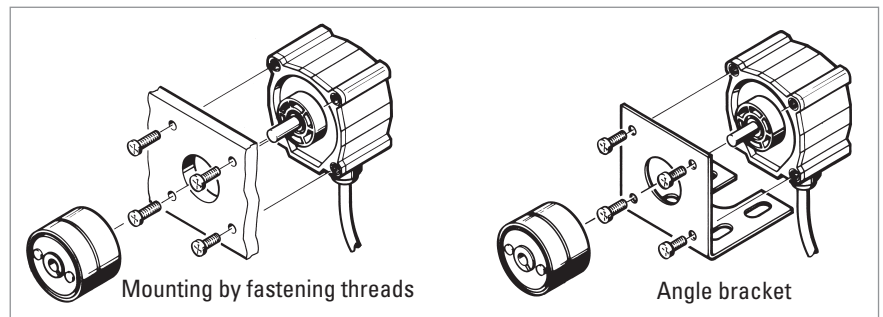

SHAFT ENCODERS WITH PILOT FLANGE

The shaft encoders with pilot flange can be installed in two ways:

- by means of the fastening threads provided on the face,
- by means of an angle bracket.

The encoder is centered by means of the centering collar on the flange.

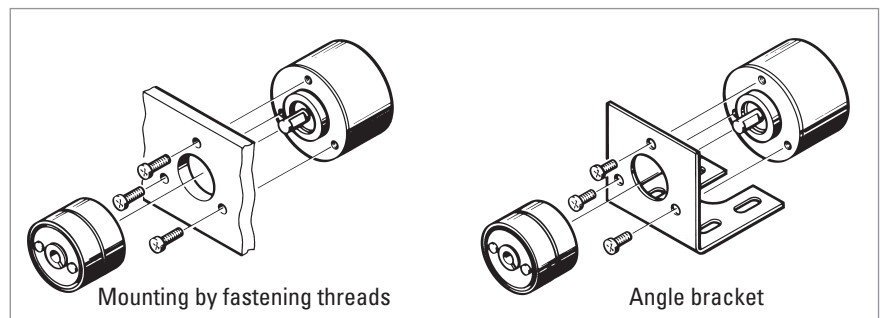

Encoder Basics

Examples of Flange Mounting

SHAFT ENCODERS WITH HOLLOW SHAFT (RI 58-D/G)

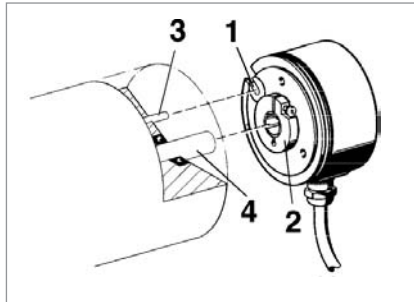

Mounting of version F, D (Clamping shaft)

- 1 Torque support
- 2 Clamping ring with cross-recess screw
- 3 Straight pin
- 4 Actuating shaft

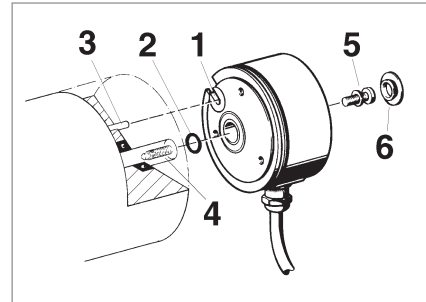

Mounting of version E (Blind shaft)

- 1 Torque support
- 2 O-ring
- 3 Straight pin
- 4 Actuating shaft with threaded bore
- 5 M4-screw with spring washer
- 6 Cap

SHAFT ENCODERS WITH HOLLOW SHAFT (RI 76, RI 80-E, AC110)

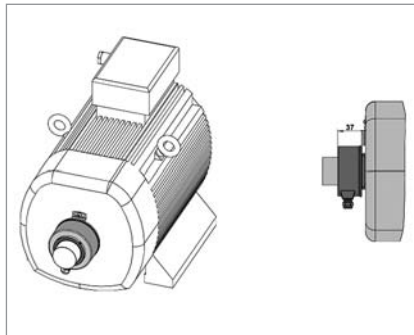

MOTOR SHAFT ENCODERS WITH HOLLOW SHAFT (E9, M9)

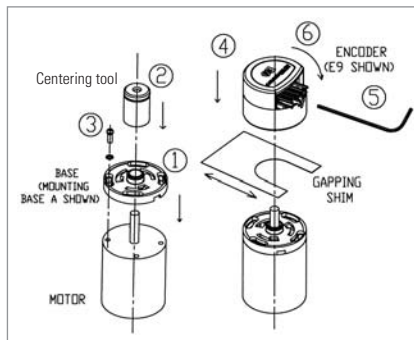

1. Place the base plate of encoder onto the motor rear end plate.
2. Install centering tool on motor shaft to center the base plate with respect to the shaft.
3. Install hardware supplied and tighten to secure the base plate. Remove centering tool.
4. Position and mount the encoder housing onto the base plate with its 3x120' bayonet snaps in their corresponding slots on the base plate. Slide the gapping shim between the base plate and the encoder from the side opposite the connector.
5. Place the hex wrench into the codewheel set screw. Tighten the set screw while pushing the codewheel down toward the gapping shim with the wrench.
6. Remove the gapping shim, push down and twist the encoder 30° clockwise to lock it in place.

SHAFT ENCODERS WITH SOLID SHAFT

Connection of solid-shaft encoders to the shaft is by means of a coupling. The coupling compensates for axial movements and lack of alignment between the shaft encoder and the drive shaft, thus preventing excessive bearing loads on the encoder shaft. For further details please refer to chapter "Accessories".

Basics of Incremental Encoders

Outputs - RS 422 - TTL

OUTPUT CIRCUIT

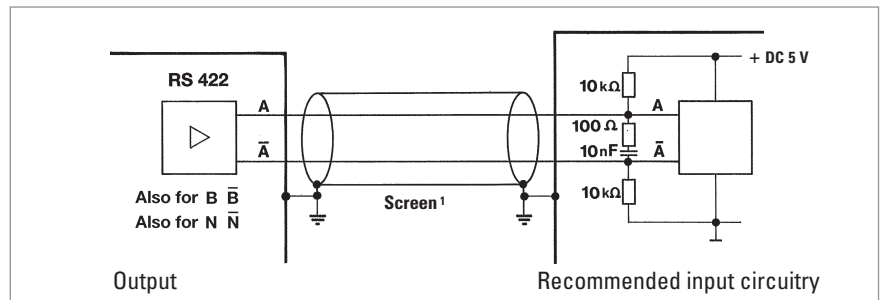

¹ Cable screen:

- not existing for RI 32, 38, 42,
- connected to encoder housing for RI 30, 36, 58, 59, 76 and RA 70

TECHNICAL DATA

Code letter	R = RS 422 + Alarm ³ (with $U_B = DC 5/10 - 30 V$) T = RS 422 + Sense ⁴ (only with $U_B = DC 5 V$)
Output signals shaft turning clockwise (cw) seen from front of encoder	<p>Square wave pulses (TTL) for channels A, B, N and their inverted signals \bar{A}, \bar{B}, \bar{N}</p>
Delay times at 1,5 m cable	<p>$\leq 100 ns \leq 100 ns$</p>
Pulse shape	
Pulse duty factor	1:1
Phasing	$90^\circ \pm 25^\circ$ electrical
Symmetry	$180^\circ \pm 25^\circ$ electrical
Max. Output frequency	300 kHz
Output voltage	DC 0 ... +5 V ²
Output level	$H \geq DC 2,5 V / L \leq DC 0,5 V$ (TTL-level)
Output load max.	$\pm 30 mA$
Short circuit protection	with $U_B = DC 5 V$: only 1 channel at a time for max. 1 s (Standard RS 422-driver) with $U_B = DC 10 - 30 V$: short circuit proof for all channels due to integrated controller
Pole protection of U_B	with $U_B = DC 5 V$: no with bei $U_B = DC 10 - 30 V$: yes

¹ Distance A to B is at least 0,45 μs (at 300 kHz)

² also for $U_B = DC 10 - 30 V$

³ Description - see Outputs Alarm

⁴ Description - see Outputs Sense

CABLE LENGTH

depending on voltage and frequency (at 25 °C) ¹:

Length	RS 422
10 m	DC 5 V, 300 kHz
50 m	DC 5 V, 300 kHz
100 m	DC 5 V, 300 kHz

¹ with Hengstler accessory cables

Basics of Incremental Encoders

Outputs - Push-pull

OUTPUT CIRCUIT

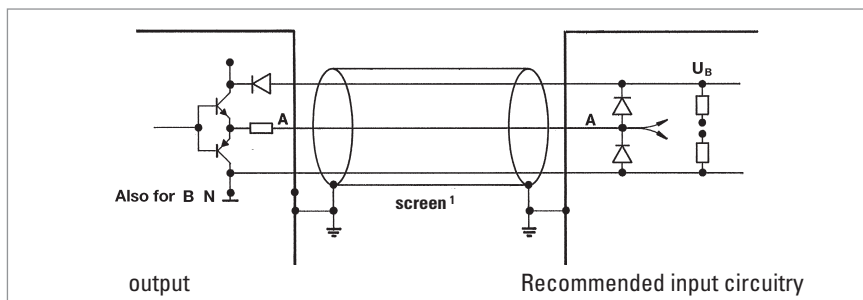

¹ Cable screen:

- not existing for RI 32, 38, 42
- Not connected to encoder housing for bei RI 41
- Connected to encoder housing for RI 30, 36, 58, 59, 76 and RA 70

TECHNICAL DATA

Code letter	K = push-pull, 10 mA with $U_B = DC 5 V$ or push-pull, 30 mA with $U_B = DC 10 - 30 V$ D = push-pull, 30 mA with $U_B = DC 5 V$		
Output signals shaft turning clockwise (cw) seen from front of encoder	<p>Square wave pulses (TTL or HTL) for channels A, B, N</p>		
Delay times at 1,5 m cable	<ul style="list-style-type: none"> ■ $\leq 100 \text{ ns}$ (DC 5 V, push-pull D) ■ $\leq 250 \text{ ns}$ (DC 5 V, push-pull K) ■ $\leq 2 \mu\text{s}$ (DC 10 - 30 V, push-pull K) 		
Pulse shape			
Pulse duty factor	1:1		
Phasing	$90^\circ \pm 25^\circ$ electrical		
Symmetry	$180^\circ \pm 25^\circ$ electrical		
Max. Output frequency	300 kHz (see cable length)		
Output voltage	$0 \dots + U_B$		
Output level	K	K	D
	push-pull (DC 10 - 30 V)	push-pull (DC 5 V)	push-pull (DC 5 V)
	$H \geq U_B - 3V$	$H \geq 2,5 V$	$H \geq 2,5 V$
	$L \leq 2 V$	$L \leq 0,5 V$	$L \leq 0,5 V$
Output load max.	$\pm 30 \text{ mA}$	$\pm 10 \text{ mA}$	$\pm 30 \text{ mA}$
Short circuit protection	all channels	all channels	1 channel ²
Pole protection of U_B	yes	yes	no

¹ Distance A to B is at least $0,45 \mu\text{s}$ (at 300 kHz)

² only 1 channel at a time for max. 1 s

CABLE LENGTH

depending on voltage and frequency (at 25 °C) ¹ :			
Length	push-pull (K) DC 5 V, 10 mA	push-pull (D) DC 5 V, 30 mA	push-pull (K) DC 10 - 30 V, 30 mA
10 m	300 kHz	300 kHz	DC 12 V, 200 kHz DC 24 V, 200 kHz DC 30 V, 200 kHz
50 m		300 kHz	DC 12 V, 200 kHz DC 24 V, 200 kHz DC 30 V, 100 kHz
100 m		300 kHz	DC 12 V, 200 kHz DC 24 V, 100 kHz DC 30 V, 50 kHz

¹ with Hengstler accessory cables

Basics of Incremental Encoders

Outputs - push-pull complementary

OUTPUT CIRCUIT

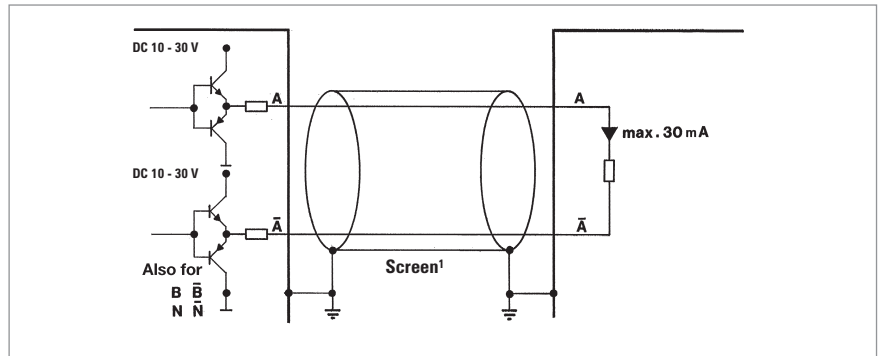

¹ cable screen connected with encoder housing

TECHNICAL DATA

Code letter	I = push-pull complementary (with $U_B = DC 10 - 30 V$)
Output signals shaft turning clockwise (cw) seen from front of encoder	<p>Square wave pulses (HTL) for channels A, B, N and their inverted signals \bar{A}, \bar{B}, \bar{N}</p>
Delay times at 1,5 m cable	<p>$\leq 250 \text{ ns}$ $\leq 250 \text{ ns}$</p>
Pulse shape	
Pulse duty factor	1:1
Phasing	$90^\circ \pm 25^\circ$ electrical
Symmetry	$180^\circ \pm 25^\circ$ electrical
Nax. output frequency	200 kHz (see cable length)
Output voltage	$0 \dots + U_B$
Output level	$H \geq U_B - 3V / L \leq 2V$
Output load max.	$\pm 30 \text{ mA}$
Short circuit protection	short circuit proof for all channels due to integrated controller
Pole protection of U_B	yes

¹ Distance from A to B is at least $0,7 \mu\text{s}$ (at 200 kHz)

CABLE LENGTH

depending on voltage and frequency (at 25°C) ¹ :	
Length	push-pull complementary
10 m	DC 12 V, 200 kHz
	DC 24 V, 200 kHz
	DC 30 V, 200 kHz
50 m	DC 12 V, 200 kHz
	DC 24 V, 50 kHz
	DC 30 V, 25 kHz
100 m	DC 12 V, 150 kHz
	DC 24 V, 25 kHz
	DC 30 V, 12 kHz

¹ with Hengstler accessory cables

Basics of Incremental Encoders

Outputs - Alarm

OUTPUT CIRCUIT

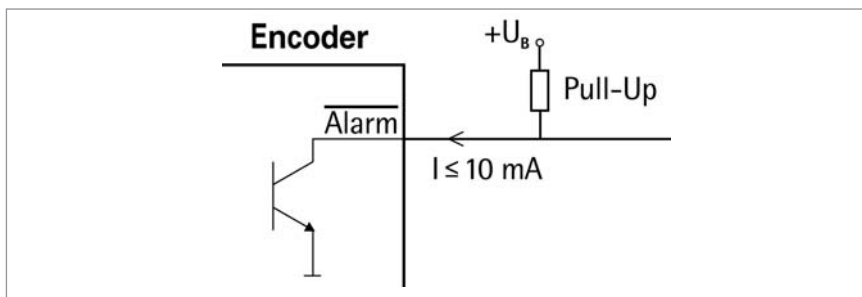

TECHNICAL DATA

Output	NPN - Open collector
Output load max.	5 mA / 24 V at $U_B = DC\ 5\ V$ 5mA / 32 V at $U_B = DC\ 10-30\ V$
Output level	Output active (failure condition): $L \leq DC\ 0,7\ V$ Output inactive: high impedance (if necessary: get H-level by an external pull-up resistor)
Malfunction indication time	$\geq 20\ ms$

FUNCTION

The rotary encoders are equipped with an electronic monitoring system that reports potential malfunctions via a separate alarm output.

The alarm output can be used for selecting an optical display (LED; for circuit, see above) or the control system (SPC or similar).

Moreover, the alarm outputs of several encoders can be interconnected to a common "systems alarm" by means of a parallel connection. The following errors are indicated:

Category I	Category II	Category III
- damaged disks	- overtemperature	- voltage range $DC\ 1\ V < U < DC\ 4\ V$
- defective LED	- overload (e. g. due to short circuit)	- voltage drop on the supply lines
- contamination		

Category I malfunctions cannot be corrected; the encoder must be replaced.

Category II malfunctions are detected by means of a thermal monitoring unit in the electronic system. The alarm message is cleared after the cause of temperature increase has been removed.

Category III malfunctions indicate insufficient supply voltage. Also included in this category are transients in the supply voltage, e.g. due to electrostatic discharge, which may distort the output signals.

This is corrected by

- readjustment to the correct voltage
- eliminating the cause of disturbance, i.e. by careful arrangement of the cables.

Basics of Incremental Encoders

Outputs - Sense at 5 V RS 422 (T)

OUTPUT CIRCUIT

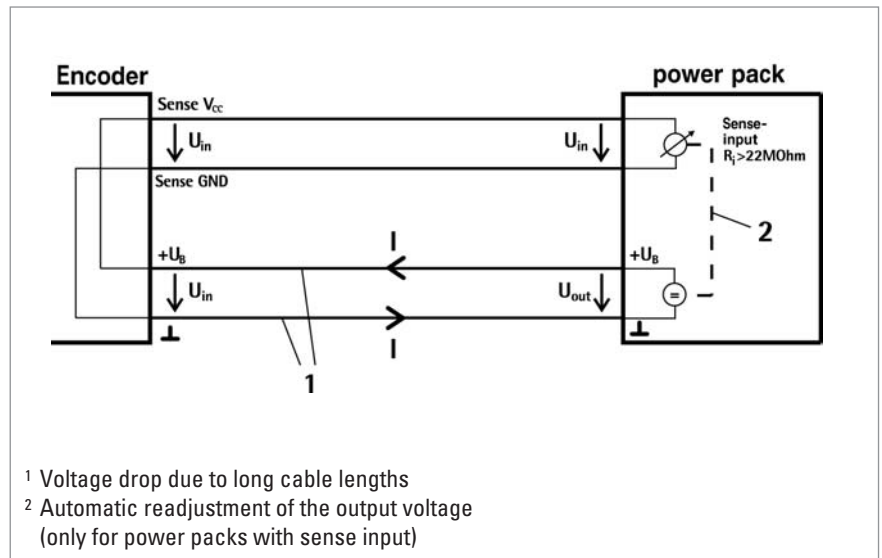

FUNCTION

The sense wires enable measuring of the actual encoder supply voltage (compensates for voltage drops due to supply current and cable resistance).

Due to the voltage drop in the cables and the voltage supply, the encoder input voltage U_{in} is less than the power pack output voltage U_{out} .

The present input voltage U_{in} is now output to the Sense V_{CC} and Sense GND cables and returns as data to the power pack.

The input resistance R_i on the power pack should amount to at least 22 MΩ so that no voltage drop occurs on these cables.

In case of power packs with sense input, it is now possible to readjust the output voltage U_{out} automatically.

Basics of Sine-Wave Encoders

GENERAL INFORMATION

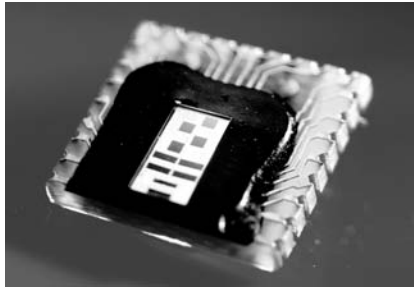

SINE-WAVE OPTOASIC TECHNOLOGY BURSTS THE LIMITS

With the introduction of the sine-wave encoder family, Hengstler has taken the opportunity to significantly rework its OptoAsic technology.

The best features have been maintained and new improvements have been introduced. One major feature that has been retained of course, is the high level of EMC reliability which we have achieved by integrating almost the complete encoder electronics into one component.

What is new is the integrated offset and amplitude control together with the in-chip optical system adjustment. In the past anybody wanting high quality, accurate sine-wave signals at low frequencies had to trade in this for bandwidth. We are now able to meet this apparently contradictory requirement with our in-built amplitude control. You can't fail to be convinced by a unit which delivers sine-wave signal with harmonic distortion better than 1% at low speed and 500 kHz max. frequency.

The advantages are crystal clear: If you need precision at slow speeds you no longer have to compromise your productivity because the encoder limits the maximum speed of your machine e.g. for tool changing processes. You can have both - accuracy and speed.

APPLICATIONS

Typical applications:

- Machine tools
- Printing machines
- Gearless elevators
- Drives

Basics of Sine-Wave Encoders

Signals

THE RIS58 SIGNALS

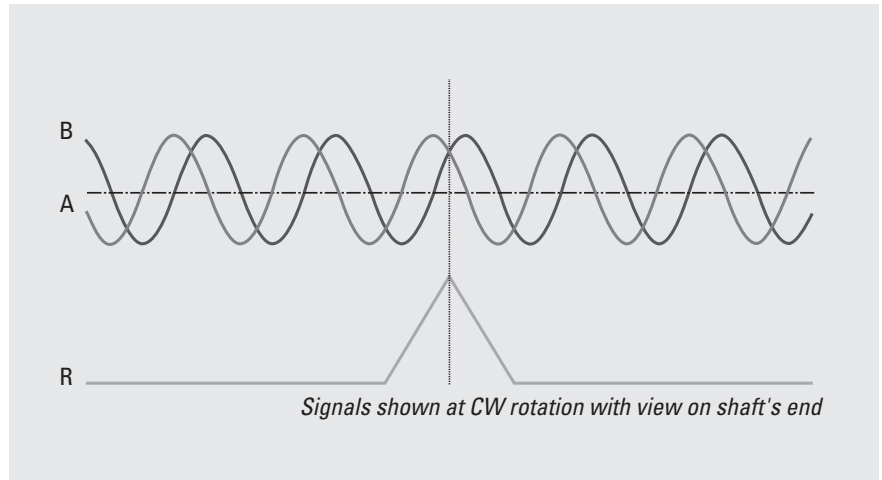

The incremental signals A and B and the zero signal R are differential voltage signals. The differential signal level is 1 V_{pp}. The zero signal appears once per revolution with a peak of 0.4 V and reaches its maximum value at the angle where the amplitudes of the A and B signals are equal. All signals have a DC-offset of 2.5 V.

THE RIS58 SIGNAL QUALITY

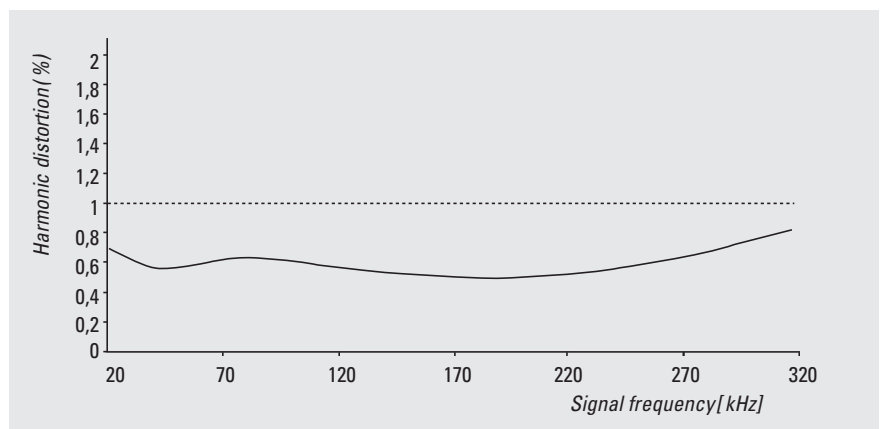

The quality of the servo loop is determined to a large extent by the absence of harmonics in the encoder's sinewave signals, particularly at low speed. In order to achieve high interpolation factors in the sequencing control, the incremental sine signals A and B are available with a harmonic distortion significantly under 1% throughout the specified temperature range. This delivers excellent synchronism and a high level of positional accuracy with servo axes.

Basics of Absolute Encoders ACURO

ABSOLUTE ENCODERS FOLLOW THE LATEST TREND: CHANGE EASILY TO ACURO

Absolute encoders save costs and provide enhanced safety - facts that are obviously important in complex installations and multi-axis machinery: Time-consuming reference runs after powering-up the supply voltage have become a thing of the past for absolute encoders. Hazardous conditions caused by reference runs (which are always necessary with incremental encoders) can be prevented right from the start. Absolute encoders - too large, too expensive?

A prejudice that is cleared up by ACURO. Even the multi turn version of ACURO is no larger than most incremental encoders and costs less than you would expect. And how about reliability? Due to their complexity, absolute encoders seem to be susceptible to faults. No problem with ACURO: once installed they will not cause trouble, due to the highest integration density and use of extremely reliable technologies to ensure safe and reliable long-term operation.

The platform concept

Hengstler's new ACURO absolute encoders feature innovative technology, simple operational and optimal functional safety. Their platform concept also allows especially compact dimensions with a modular design, which always ensures the right version for each individual application in the field of motor feedback and automation engineering. Equipped with the new open BiSS interface these encoders are a good and future oriented investment.

The mechanical construction of ACURO is rugged and precise. Double high-precision ball bearings guarantee reliable long-term operation even at speeds of up to 12000 rpm. ACURO is equipped with the commercially available mechanical interfaces, including solid shaft or hub shaft, synchro-flange or clamping flange.

ABSOLUTE ENCODERS ARE DIFFERENTIATED ACCORDING TO:

Singleturn version

1 revolution (= 360 °) is coded in n steps. After a rotation of over 360 ° the code is repeated.

Multiturn version

Apart from measuring 360 ° (1 revolution) further coded revolutions can be recorded e.g for applications in combination with lead screws or timing belts. Hengstler is using the principle of a mechanical memory (gearbox, which is unmatched in reliability and EMC).

Basics of Absolute Encoders ACURO

High-Tech Features in a Modular System

INNOVATIVE TECHNOLOGY

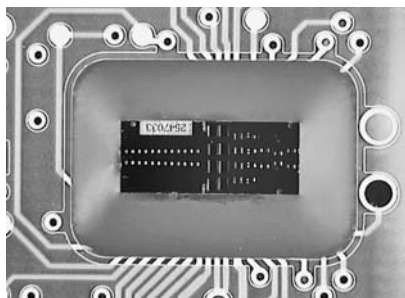

Hengstler's ACURO series comprises a complete range of absolute encoders, all in OPTOASIC technology. OPTOASIC units combine all required optical and electronic components in only one silicon chip.

This new technology is tailored to the user's needs and offers advantages previously unknown in the field:

- **High degree of reliability** due to differential scanning and single-step Gray code.
- **Fail-safe** due to the elimination of more than a hundred components
- **Long serviceable lifetime** due to state-of-the-art semiconductor technology-

- High degree of **electromagnetic compatibility** due to elimination of macroscopic low-current paths.

Our new absolute shaft encoders have an excellent price/performance ratio. As a further feature the encoders are fully backward compatible due to identical mounting flanges and electrical interfaces.

This makes it easy for the user to switch from incremental to absolute shaft encoders.

PROGRAMMABLE ABSOLUTE SHAFT ENCODERS

All essential parameters are user-programmable.

Additional advantages are uncomplicated subsequent data processing, electronic adjustment and add-on optimization of mechanical systems which are subject to tolerances.

Furthermore, storage and maintenance are more cost-efficient: the same encoder may be used for a variety of applications and assigned to its task at the place of installation.

APPLICATIONS

The new encoders are, for example, perfectly suited to determine angular positions in automated systems with reliable and precise operation.

Absolute encoding eliminates the need for a reference run after interruptions (such as power failures).

ACURO is the right match for a wide range of applications - from medical technology, elevators, all printing, paper processing or metal-processing machinery, such as presses and saws, right through to highly-dynamic drives.

INTERFACES



Of course, the user has a selection of the most advanced interface technology available:

- Tristate parallel drivers
The symmetrical push-pull drivers are fully short circuit proof, overload protected and polarity protected in a range from 10 to 30 V.
Parallel bus systems are easy to realize. So you save in cabling expenses.
- CAN
Bus specifications according to CAN High-Speed ISO/DIS 11898 for transfer rates up to 1 MBaud.
- Suconet K1
Klöckner-Moeller 2 wire fieldbus
- DeviceNet
- Based on CAN layer 2 (data link layer)
- Up to 64 nodes and 500 Kbaud speed
- Configuration via network

- INTERBUS
Interface including the potential-free power supply is already integrated in the housing with a diameter of only 58 mm.
- SSI
The encoders can also be supplied with synchronous-serial interface (SSI) which is available worldwide.
This allows trouble-free connection to commercial processing components.
- Profibus DP
Protocol according to encoder profile class C2 (programmable)
- BiSS
- bidirectional and fully digital
- synchronous serial data
- licence-free
- up to 8 slaves per master

Basics of Absolute Encoders ACURO

Open Digitale Sensor Interface (BiSS)

GENERAL INFORMATION

The bidirectional digital sensor interface BiSS safeguards communication between position encoders or measuring devices and industrial controls, such as a drive control, for example, and if necessary can transmit measurement values from up to 8 sensors simultaneously.

For 1 to 8 subscribers the interface master provides a clock signal for the simultaneous capture of all position data and for the synchronous-serial data transmission which

follows on from this. Just four unidirectional RS422 data lines are required; the slave electronics, kept to an absolute minimum, are incorporated on the sensor ICs.

When the master sends a clock pulse on line MA, the slave answers directly on return line SL with the recorded position data. Commands and parameters can be swapped on a PWM pulse form; this is, however, not necessary to start the BiSS protocol.

TRANSFER SEQUENCE

With each data cycle the master learns and compensates for line delays, thus permitting clock rates of up to 10 Mbit/s even for cable lengths of up to 100 m. Changes in line conditions which occur during cable drag, for example, are corrected. The precision of synchronization among several position encoders along various axes is less than 1 microsecond; the master also makes the signal delay it has recorded accessible to the control unit, allowing further optimization.

The BiSS protocol classifies each subscriber in one of the following data sections: sensor data, multi cycle data or register data. These data sections have various setups with regard to access and transmission performance so that a number of different sensor applications are catered for. Bidirectional parameter communication for device configuration - also applicable to what are known as OEM parameters - is

usually consigned to the register data section. Data which alters gradually, such as revolution counts or drive temperatures, is allocated to the multi cycle data section, with rapidly changing angle data being assigned to the sensor data section.

Control cycle times of less than 10 μ s are thus not a problem, even for data words of up to 64 bits in length. There is enough room in the protocol for redundancy; this space is normally used to implement a CRC (cyclic redundancy check). Framed by just one start and one stop bit, the sensor data is transmitted at the best-possible core data rate; a single multi cycle data bit is optional. Also captured when triggered, the multi cycle data bits make up a second in-band protocol which helps to increase the efficiency of the sensor data; permanent monitoring of the position and operation of the drive is possible without interfering with the control cycle.

Circuit diagram of an absolute encoder

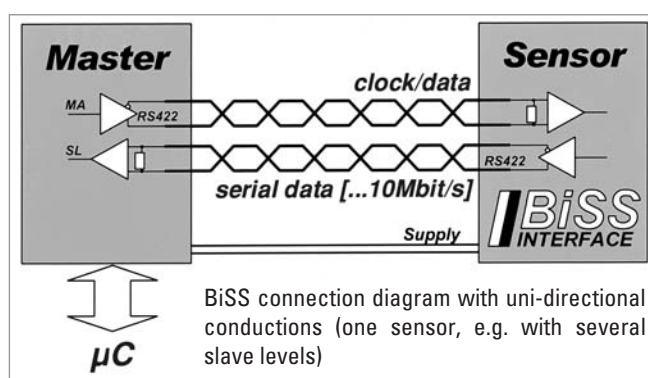

Configuration

Specific product developments of individual users are not restricted or made unnecessarily expensive by a compulsory compatibility.

A BiSS subscriber is described with just a few parameters and the XML-descriptive file included with the delivery simplifies start up of the control system.

i For further information see: www.biss-interface.com

Basics of Absolute Encoders ACURO

Synchronous-Serial Interface (SSI)

GENERAL INFORMATION

In many cases, absolute shaft encoders are subject to severe mechanical stresses and to electrical and magnetic fields that contaminate the site.

Therefore, special design measures are needed to combat dirt, dust and liquids in industrial environments.

Our absolute shaft encoders are of state-of-the-art rugged mechanical construction, and the electronic components are very compact.

A main consideration for immunity to interference is the data transfer from the shaft encoder to the control system. The control system must be able to read the readings from the shaft encoder without errors. Under no circumstances should undefined data be transmitted, for example at the changeover point.

The major differences between the concept of synchronous-serial data transfer for absolute shaft encoders described here and parallel and asynchronous serial forms of data transfer are:

- less electronic components
- less cabling for data transfer
- the same interface hardware, regardless of the absolute shaft encoder's resolution (word length)
- electrical insulation of the shaft encoder from the control system by optocouplers
- open-circuit monitoring by constant current
- data transfer rates up to 1.5 megabits per second (depending on the length of line)
- ring-register operating possible.

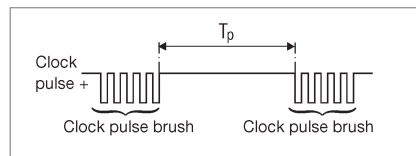

TRANSFER SEQUENCE

For correct transfer of the data a defined number of pulses (clock pulse brush) must be applied to the clock input of the absolute shaft encoder. Next, a pause T_p must be observed. As long as no clock signal is applied to the shaft encoder, its internal parallel/serial shift register remains switched to parallel. The data change continuously, corresponding to the current position of the shaft encoder's shaft.

As soon as a clock pulse brush is applied to the clock input again, the instantaneous angular data is recorded.

The first shift of the clock signal from high to low ① actuates the shaft encoder's internal retriggerable mono-stable element, whose storage time t_m must be greater than the clock signal's period T .

The output of the monostable element controls the parallel/serial register via terminal P/S (parallel/serial).

Block diagram of an absolute shaft encoder

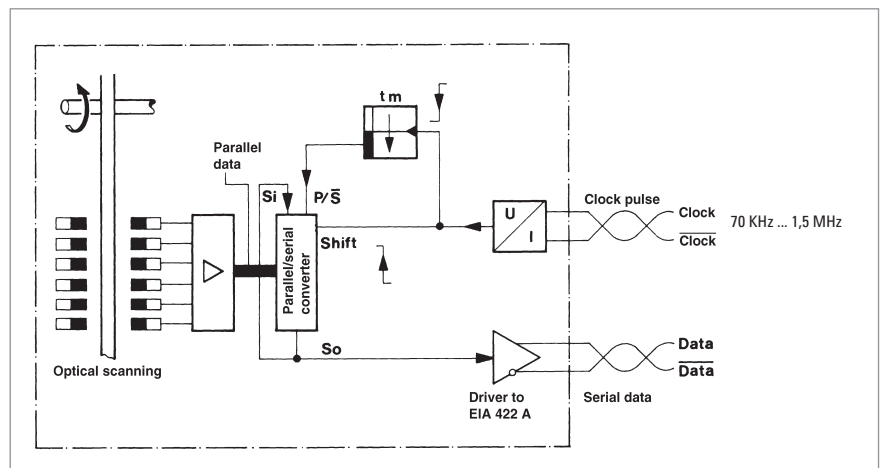

Basics of Absolute Encoders ACURO

Synchronous-Serial Interface (SSI)

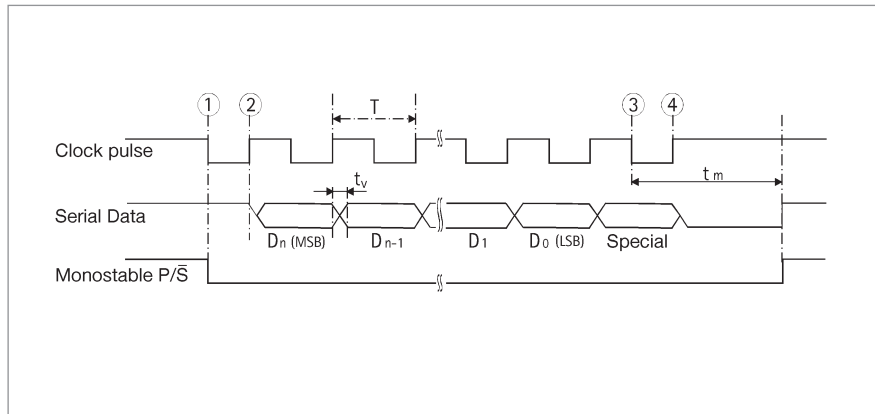

T = clock pulse period

t_m = storage time of monostable element

t_m ranging from 10 μ s to 30 μ s

t_v = 100 ns

The number of clock pulses necessary for data transfer is independent of the resolution of the absolute shaft encoder.

The clock signal can be interrupted at any point, or continued in ring-register mode for repeated polling.

With the first shift of the clock signal from low to high ② the most significant bit (MSB) of the angular data is applied to the shaft encoder's serial output.

With each succeeding rising edge, the next less significant bit is shifted to the data output.

After transmission of the least significant bit (LSB) the Alarm bit or other special bits are transferred, depending on configuration. Then the data line switches to low ③ until the time t_m has passed.

A further transfer of data cannot be started until the data line switches to high ④ again. If the clock pulse sequence is not interrupted at point ③, the ring-register mode is activated automatically. This means that the data stored at the first clock pulse transition ① are returned to the serial input S_i via the terminal S_0 . As long as the clock pulse is not interrupted at ③, the data can be read out as often as wanted (multiple transfer).

Basics of Absolute Encoders ACURO

Synchronous-Serial Interface (SSI)

Input circuit

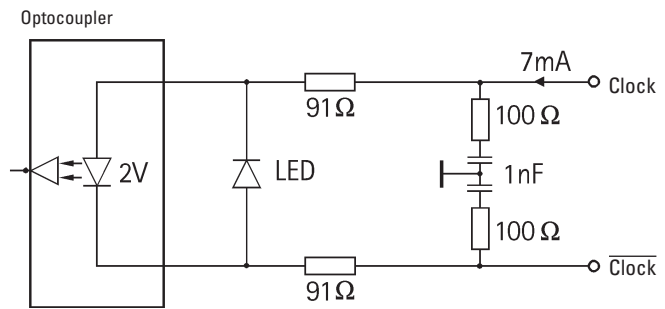

Output circuit

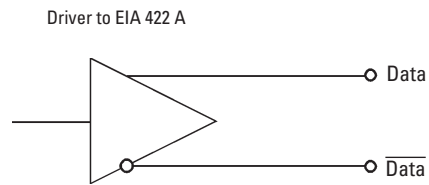

RECOMMENDED DATA TRANSMISSION RATE

The maximum data transmission rate depends on the length of cable:

Cable length	Baud rate
< 50 m	< 400 kHz
< 100 m	< 300 kHz
< 200 m	< 200 kHz
< 400 m	< 100 kHz

Basics of Absolute Encoders ACURO

INTERBUS

GENERAL INFORMATION

INTERBUS is a real-time bus for the sensor-actor-level which is able to transfer data with a small overhead in a range of up to 4 bytes per subscriber for a maximum of 256 subscribers.

It is characterized by a circular transmission with a fixed message frame and a central master (e.g. SPC switching-in assembly).

TRANSFER SEQUENCE

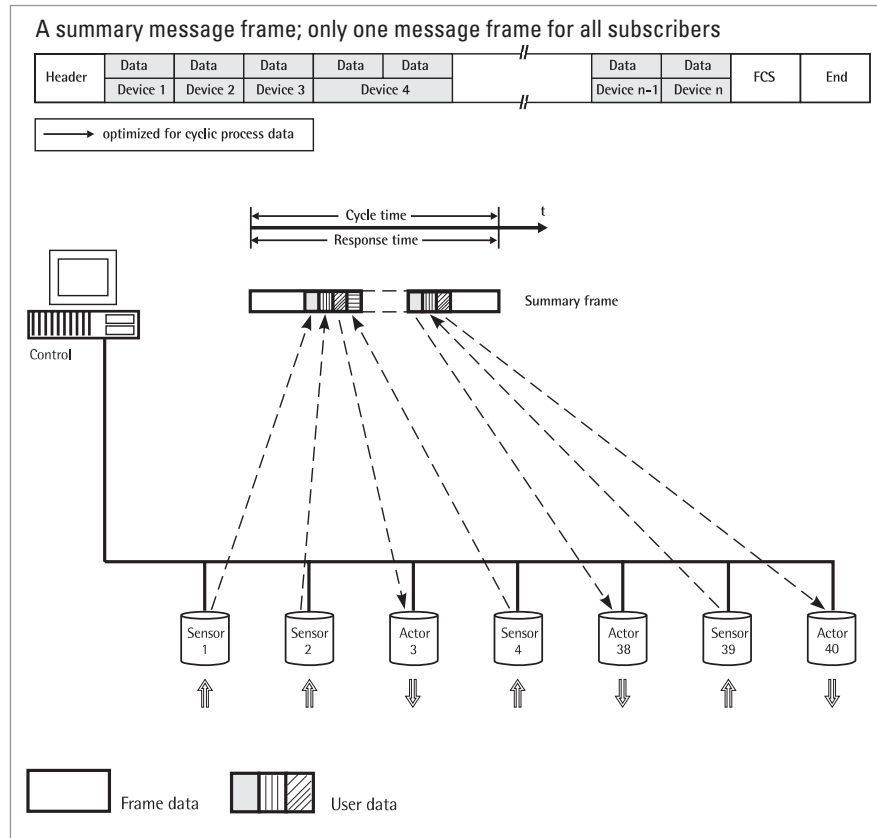

WHAT ARE THE BENEFITS OF INTERBUS COMPARED WITH A CONVENTIONAL SYSTEM WIRING?

- Lower costs for cables and wiring
- Lower noise sensitivity
- Many control signals which were analog before are now available as digital signals and directly transferable by INTERBUS
- Simple layout, installation and starting procedure
- High efficiency (net data rate): the percental share of the message header and of the terminating sequence decreases with a growing number of subscribers
- Data of all subscribers are stored at the same time and transferred sub-sequently
- Reaction time can easily be determined. It only depends on the system's total extension; this is important for controlling tasks
- Constant sampling rate for reference inputs and actual values; both are transferred in one bus cycle
- Considerations of priority are unnecessary since all subscribers have the same priority

INTERBUS

- No system-parameter definition before starting procedure
- Data integrity is secured by 16-bit-CRC (according to CCITT polynomial) done for each transmission
- Sophisticated diagnostic software for the central bus controller: a point of error can specifically be isolated; in each case of malfunction there is a possibility to close the circular system in every single bus clip.

Encoder manufacturers are joined together in the ENCOM user group; drive manufacturers in DRIVECOM.

The user groups shall maximize the benefit for the customer by standardization of data transmission.

There is a high availability of devices with INTERBUS interface, and the bus mode has already been successful in industrial use.

Devices with an INTERBUS interface for process control are now available from more than 200 manufacturers.

ENCOM USER GROUP



The following device classes defined by ENCOM are used for absolute shaft encoders:

Class 2 (K2):

- 32-bit process data
- Binary
- Right-justified
- Readable only
- No control bits or status bits

Class 3 (K3):

- 32-bit process data
- Coded according to manufacturer specifications
- Right-justified
- 7 status bits and control bits

Basics of Absolute Encoders ACURO

INTERBUS

TECHNICAL DATA

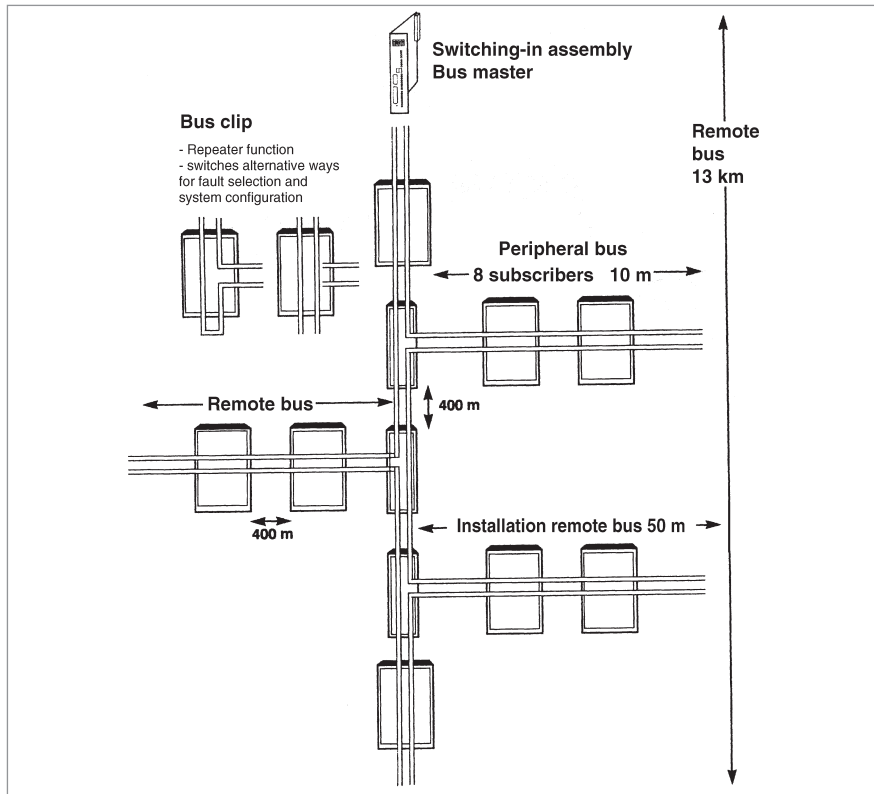

INTERBUS is physically divided into:

Remote bus

- Voltage difference transmission RS 485
- Max. cable length between two bus clips: 400 m
- Max. overall cable length of remote bus: 13 km
- A maximum of 64 bus clips/modules may be directly connected to the remote bus

Peripheral bus

- 5 V voltage interface
- Max. overall cable length of peripheral bus: 10 m
- A maximum of 8 modules may be connected

Installation remote bus

- For modules with enclosure class IP65 (e.g. HENGSTLER absolute shaft encoders)
- Voltage difference transmission RS 485
- Max. overall cable length: 50 m
- Connection via bus clip or passive T-manifold
- Each subscriber has an electrically isolated voltage transformer
- 24 V supply may be led via the bus line or be connected to the T-manifold
- 8 modules may be connected.

The transmission speed is **500 kBit/s**.

INTERBUS

INTERBUS DIAGNOSTIC CONCEPT

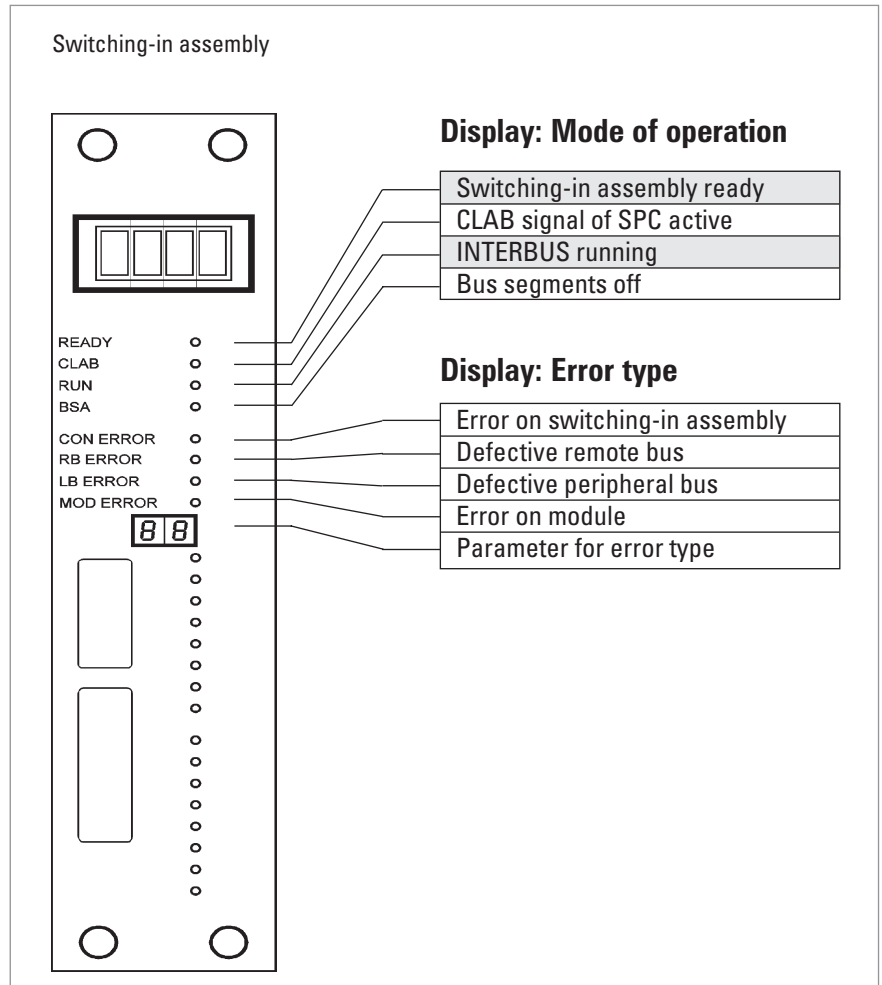

The diagnostic system is able to indicate peripheral and controller errors beside the selection of faults. Due to a row of LEDs comprising 16 bits, available on most switching-in assemblies, decentralized process states can be displayed centrally.

- Status display on control system for inputs and outputs without hand programming unit

- Self-acting fault detection and display with point and type of error without user programming

- Usual diagnosis by hand programming unit can be kept

- Diagnostic representation is always the same regardless of the control system.

i For further information see:
www.interbusclub.com/de

CANopen

GENERAL INFORMATION

The AC 58 is an absolute shaft encoder (encoder, angle encoder). The version described in this technical manual sends its current position to another station via the "CAN-bus" transmission medium (physically: screened and twisted two-wire line).

The serial bus system CAN (Controller Area Network), which had been originally developed by Bosch/ Intel for automotive uses, is gaining ground in industrial automation technology. The system is multimaster-compatible, i.e. several CAN- stations are able to request the bus at the same time. The message with the highest priority (determined by the identifier) will be received immediately.

The data transfer is regulated by the message's priority. Within the CAN system, there are no transport addresses, but message identifiers. The message which is being sent can be received by all stations at the same time (broadcast).

By means of a special filter methods, the station only accepts the relevant messages. The identifier transmitted with the message is the basis for the decision as to whether the message will be accepted or not.

The bus coupler is standardised according to the international standard ISO-DIS 11898 (CAN High Speed) standard and allows data to be transferred at a maximum rate of 1 MBit/ s. The most significant feature of the CAN-protocol is its high level of transmission reliability (Hamming distance = 6).

The CAN-Controller Intel 82527 used in the encoder is **basic** as well as **full-CAN** compatible and supports the **CAN-specification 2.0 part B (standard protocol with 11-bit- identifier** as well as **extended protocol with 29-bit identifier)**. Up to now, only 11-bit identifiers have been used for CANopen.

FIELD OF APPLICATION

In systems, where the position of a drive or of any other part of a machine has to be recorded and signalled to the control system, the AC 58 can assume this function. The AC 58 can resolve, for instance, positioning tasks by sending the check-back signal concerning the present drive position via the CAN bus to the positioning unit.

Basics of Absolute Encoders ACURO

CANopen

CANOPEN COMMUNICATION MODEL AND PROFILE

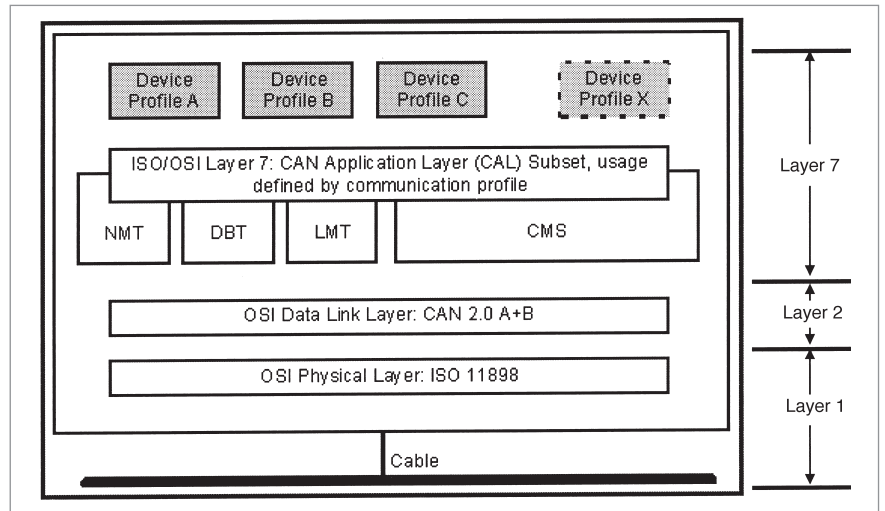

Layer 1 (Physical Layer): ISO-DIS 11898 (CAN High Speed)

Layer 2 (Data Link Layer): ISO-DIS 11898 (CAN High Speed)

Layer 7 (Application Layer): CiA DS 301 (CANopen CAL-based Communication Profile)
+ Device profile CiA DS 4xx (CANopen Device Profile for xx)

For the following devices, profiles already exist:

- CiA Draft Standard Proposal 401 for Input/Output Modules
- CiA Draft Standard Proposal 402 for Drives and Motion Control
- CiA Work Item 403 for Human-Machine Interfaces
- CiA Work Draft 404 for Closed-Loop Controllers and Transformers
- CiA Work Item 405 for IEC-1131 Interfaces
- **CiA Draft Standard Proposal 406 for Encoders**
- CiA Work Item 407 for Public Transport
- CiA Work Item 408 for Fork-Lifts

CANopen

THE CANOPEN PROFILE

About two and a half years after the CiA, the association of the user and manufacturer of CAN products, had adopted the CAN Application Layer (CAL), CANopen and the respective device profiles paved the way for the development of open systems.

CANopen has been developed under the technical direction of the Steinbeis Transfer Centre for Automation (STA Reutlingen; Germany) on the basis of the layer 7 CAL specification.

Compared with CAL, CANopen only provides the functions needed for this special purpose. CANopen is thus a part of CAL which has been optimised for application purposes and allows for a simpler system structure as well as for simpler devices.

CANopen has been optimised for a quick transfer of data in real-time systems and has been standardised for different device profiles.

The CAN in Automation (CiA) association of users and manufacturers is responsible for the establishing and the standardisation of the respective profiles.

The RA58 with CANopen meets the requirements laid down in the communication profile (CiA DS 301) and in the device profile for encoders.

CANopen allows for:

- auto configuration of the network,
- comfortable access to all device parameters.
- synchronisation of the devices,
- cyclical and event-controlled process data processing,
- simultaneous data input and output.

CANopen uses four communication objects (COB) with different features:

- Process Data Objects (PDO) for real-time data
- Service Data Objects (SDO) for the transfer of parameters and programs
- Network Management (NMT, Life-Guarding)
- predefined objects (for synchronisation, time stamp, emergency message)

All device parameters are stored in an object directory. The object directory contains the description, data type and structure of the parameters as well as their addresses (index).

The directory consists of three parts: communication profile parameters, device profile parameters and manufacturer specific parameters.

THE ENCODER DEVICE PROFILE (CIA DSP 406)

This profile describes a binding, but manufacturer-independent definition of the interface for encoders. The profile not only defines which CANopen functions are to be used, but also how they are to be used. This standard permits an open and manufacturer-independent bus system.

The device profile consists of two object categories

- the standard category C1 describes all the basic functions the shaft encoder must contain

- the extended category C2 contains a variety of additional functions which either have to be supported by category C2 shaft encoders (mandatory) or which are optional. Category C2 devices thus contain all C1 and C2 mandatory functions as well as, depending on the manufacturer, further optional functions.

Furthermore, an addressable area is defined in the profile, to which, depending on the manufacturer, different functions can be assigned.

CANopen

DATA TRANSFER

In CANopen, the data is transferred by means of two different communication types (COB = Communication Object) with different features:

- **Process Data Objects (PDO)**
- **Service Data Objects (SDO)**

The priority of the message objects is determined by the COB identifier.

The **process data objects (PDO)** serve the highly dynamic exchange of real-time data (e.g. position of the shaft encoder) with a maximum length of 8 Byte. This data is transferred with high priority (low COB identifier). PDOs are broadcast messages and put their information simultaneously at the disposal of all desired receivers.

The **service data objects (SDO)** form the communication channel for the transfer of device parameters (e.g. programming of the shaft encoders' resolution). Since these parameters are transferred acyclically (e.g. only once when running up the network), the SDO objects have a low priority (high COB identifier).

COB IDENTIFIER

For an easier administration of the identifiers, CANopen uses the "Predefined master/Slave Connection Set"). In this case, all identifiers with standard values are defined in the object directory. However, these identifiers can be modified according to the customers' needs via SDO access.

The 11-bit identifier consists of a 4 Bit function code and a 7 Bit node number.

Bit-No.	10	9	8	7	6	5	4	3	2	1	0
Type	Function code				Node number						
Assignment ¹	x	x	x	x	0	0	x	x	x	x	x

¹ x = binary value can be selected freely 0 or 1); 0 = 0 value is fixed

The higher the value of the COB identifier, the lower the identifier's priority!

NODE NUMBER

The 7-bit node number is set by means of the hardware via the 5 DIP switches on the encoder's back.



For further information see CAN user organisation:

www.can-cia.de

Basics of Absolute Encoders ACURO

DeviceNet

BACKGROUND AND TECHNOLOGY

Background

- The basic technology was developed by Allen-Bradley
- Introduced in March 1994
- The ODVA (Open DeviceNet Vendor Association) was founded in April 1995

Technology

- CAN-Layer 2 (Data Link Layer) - ISO 11898 and 11519-1
- DeviceNet covers layer 7 (Application Layer) and layer 1 (Physical Layer), developed for industrial automation

Main benefits

- Reduced cabling and installation effort
- Reduced run-in time
- Reduced down-time
- Fast error elimination
- Devices can be removed, replaced and inserted without having to shut the network down
- Devices from various manufacturers can be exchanged
- Devices are configured over the network

LINEAR BUS TOPOLOGY

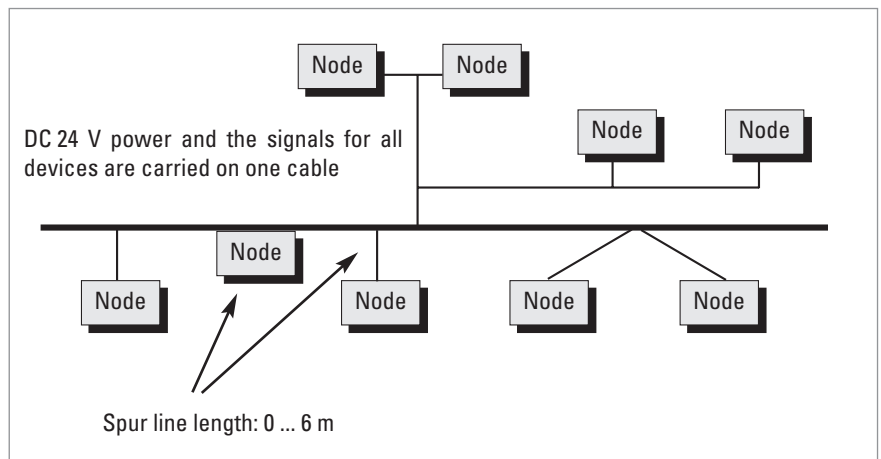

NETWORK SPECIFICATION

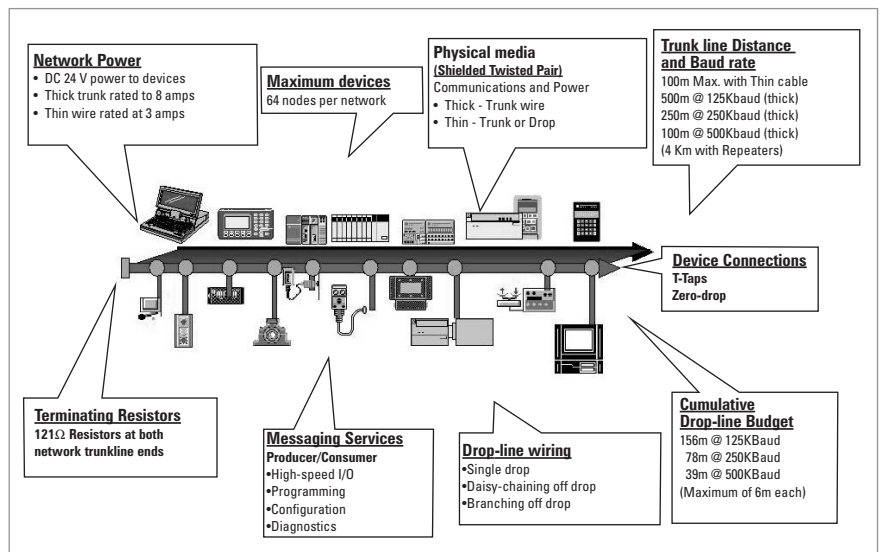

For more information about deviceNet please contact:

<http://www.odva.org>

e-mail: odva@powerinternet.com

Profibus-DP

GENERAL INFORMATION

The basic functions of the PROFIBUS DP are here only described in extracts. For additional information, please refer to the standards on PROFIBUS DP, i.e. DIN 19245-3 and EN 50170 respectively.



INTRODUCTION

The AC 58 is an absolute shaft encoder (encoder, angle encoder). The version described in this manual sends its current position to another station via the transmission medium "PROFIBUS DP" (physically: screened and twisted pair line). The AC 58 supports all class 1 and 2 functions listed in the encoder profile.

PROFIBUS-DP is manufacturer independent, open field bus standard for a variety of applications in the field of production, process and building services automation. The requirements of openness and independence from the manufacturer are stipulated in the European standard EN 50 170.

PROFIBUS-DP permits the communication of devices produced by different manufacturers without any particular adaptations of the interfaces.

PROFIBUS DP is a special standard version for a quick data exchange within the field level which has been optimised in terms of speed and low connection costs. Central control systems like, for example SPC/ PC communicate via a quick, serial connection with local field devices like drives, valves, or encoders. The data exchange between these devices is predominantly cyclical. The communication functions required for this exchange are determined by the basic functions of the PROFIBUS DP according to the EN 50 170 European standard.

FIELD OF APPLICATION

In systems, where the position of a drive or of any other part of a machine has to be recorded and signalled to the control system, the AC 58 can assume this function.

The AC 58 can resolve, for instance, positioning tasks by sending the checkback signal concerning the present drive position via the PROFIBUS DP to the positioning unit.

BASIC FUNCTIONS OF THE PROFIBUS-DP

The central control system (master) cyclically reads out the input information from the slaves and writes the output information to the slaves. For this purpose, the bus cycle time has to be shorter than the program cycle time of the central SPC, which amounts to approx. 10 ms for various applications.

Apart from the cyclical user data transfer, the PROFIBUS DP version also disposes of powerful functions for diagnosis and initial operation procedures. The data traffic is controlled by watchdog functions on both the slave and the master side. The following table summarises the basic functions of the PROFIBUS DP.

Basics of Absolute Encoders ACURO

Profibus-DP

Transmission technology:	<ul style="list-style-type: none">• RS-485 twisted pair line• Baud rates ranging from 9.6 kBit/s up to 12 MBit/s
Bus access:	<ul style="list-style-type: none">• Token passing procedure between the masters and master-slave procedures for slaves• Monomaster or multimaster systems possible• master and slave devices, max. of 126 stations at a single bus
Communication:	<ul style="list-style-type: none">• Point-to-point (user data communication) or multicast (control commands)• cyclical master-slave user data communication and acyclical master-master data transfer
Operating state:	<ul style="list-style-type: none">• Operate: cyclical transfer of input and output data• Clear: The input data are read, the output data remain in the safe status• Stop: only master-master data transfer is possible
Synchronisation:	<ul style="list-style-type: none">• Control commands enable a synchronisation of the input and output data• Sync mode: Output data are being synchronised
Functionality:	<ul style="list-style-type: none">• Cyclical user data transfer between DP master and DP slave(s)• Single DP slaves are dynamically activated or deactivated• Control of the DP slave's configuration. Powerful diagnostic functions, 3 stepped diagnostic message levels.• Synchronisation of in- and/ or output• Address assignment for the DP slaves via the bus• Configuration of the DP masters (DPM1) via the bus• Maximum of 246 byte input and output data per DP slave possible
Protection functions:	<ul style="list-style-type: none">• All messages are transferred with a hamming distance of HD=4• Response control at the DP slaves• Access protection of the DP slaves' input/ output• Monitoring of the user data communication with adjustable control timer at the master
Device types:	<ul style="list-style-type: none">• DP master class 2 (DPM2), e.g. programming/ project planning devices• DP master class 1 (DPM1), e.g. central automation devices like SPC, PC• DP slave e. g. devices with binary or analogue input/ output, drives, valves

ESSENTIAL FEATURES/ SPEED

The PROFIBUS DP only requires approx. 1 ms at a speed of 12 MBit/s in order to transfer 512 Bit input and 512 Bit output data by means of 32 stations.

The following diagram shows the usual PROFIBUS DP transfer time interval in relation to the number of stations as well as the transmission speed. The high speed can be above all explained by the fact that the input and output data within a message cycle are transferred by using the layer 2 SRD service (Send and Receive Data Service).

Diagnostic function:

The comprehensive diagnostic functions of PROFIBUS DP allow a quick localisation of the errors. The diagnostic messages are transferred by means of the bus and are assembled at the master. They are subdivided in three levels:

Basics of Absolute Encoders ACURO

Profibus-DP

BASIC FEATURES/SPEED

Station-related diagnosis

Messages on the general readiness for service of a station, like for example, overtemperature or undervoltage.

Module-related diagnosis

These messages indicate that a diagnosis within a certain I/O part (e.g. 8 Bit output module) of a station is in hand.

Channel related diagnosis

The error cause in relation to a single input/output bit (channel) is indicated here, like for example, a short-circuit at output line 7.

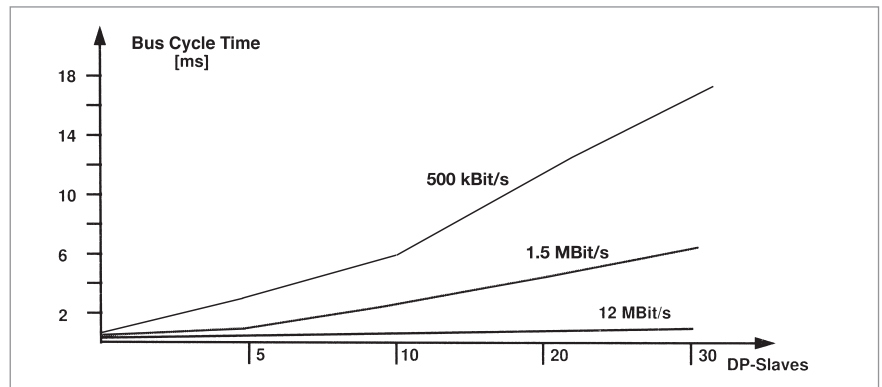

Bus cycle time of a PROFIBUS DP monomaster system

Boundary conditions: Each slave has 2 byte input and 2 byte output data; the minimum slave interval time amounts to 200 microseconds; TSDI = 37 Bit times, TSDR = 11 Bit times

CONFIGURATION OF THE SYSTEM AND DEVICE TYPES

By means of PROFIBUS DP, mono- and multimaster systems can be realised. For this reason, a high level of flexibility in terms of the system configuration can be achieved. A maximum of 126 devices (master or slaves) may be connected to a bus. The definitions for the system configuration contain the number of stations, the assignment of the station address to the I/O addresses, the data consistency of the I/O data, the format of the diagnostic messages and the bus parameters used. Each PROFIBUS DP system consists of different device types. There are three device types to be distinguished:

DP master class 1 (DPM1)

These devices are central control systems exchanging information with the local stations (DP slaves) during a fixed message cycle. Typical devices of this kind are stored-program controllers (SPC), PC or VME systems.

DP master class 2 (DPM2)

Programming, configuration devices, and operator panels belong to this category. They are used for the initial operation procedures in order to establish the configuration of the DP system, or to operate the plants in the course of operation.

DP slave

A DP slave is a peripheral I/O rack (I/O, drives, HMI, valves) that reads the input information and sends output information to the peripheral equipment. Devices which provide only input or only output information might also be used.

The amount of input and output information is device specific and must not exceed 246 byte for the input and 246 byte for the output data.

Basics of Absolute Encoders ACURO

Profibus-DP

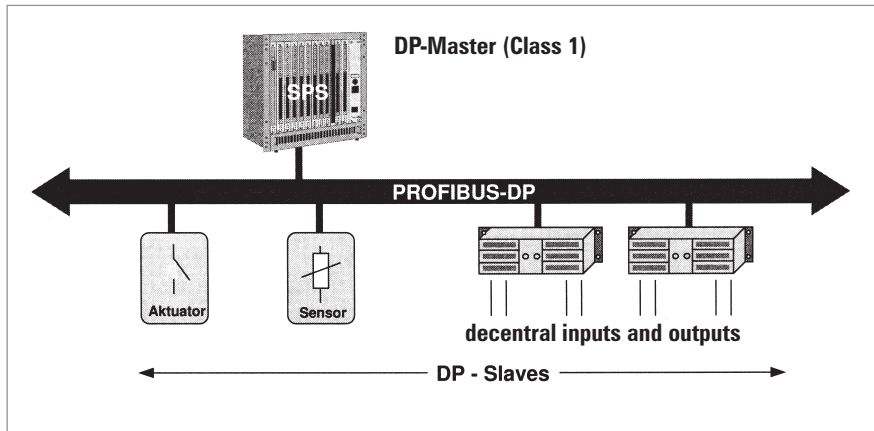

PROFIBUS DP monomaster system

In the case of monomaster bus systems, there is only one master active at bus during the on-line phase of the bus system. The above diagram shows the system configuration of a monomaster system. The SPC based control system is the central control element. By means of the transmission medium, the DP slaves are locally linked to the SPC control system. By using this system configuration, the shortest bus cycle time can be obtained.

In the multimaster mode, several masters are linked to a single bus. They either form independent subsystems consisting of one DPM1 and its corresponding DP slaves each, or additional configuration and diagnostic devices (see diagram below). The I/O maps of the DP slaves can be read by all DP masters, but only one DP master, the one which has been assigned DPM1 during project planning, is able to write the output information. Multimaster systems attain a medium bus cycle time.

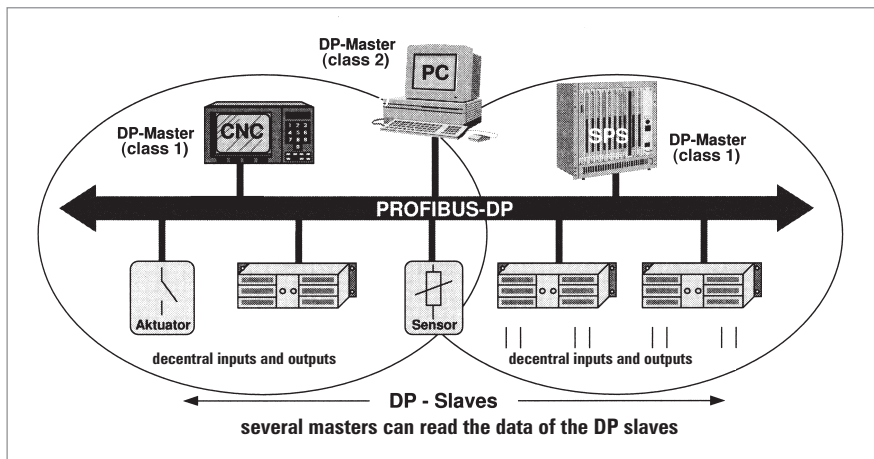

PROFIBUS-DP Multi-Master System

Profibus-DP

SYSTEM PERFORMANCE

In order to obtain a high level of exchangeability between the devices, the system performance of PROFIBUS DP has also been standardised. It is mainly determined by the operational status of the DPM1.

The DPM1 can either be controlled locally or via the bus by the project planning device. The following three main states can be distinguished:

Stop

There is no data traffic between DPM1 and the DP slaves.

Clear

The DPM1 reads the input information of the DP slaves and maintains the safe status of the DP slaves' output.

Operate

The DPM1 has entered the data transfer phase. In case of a cyclical data traffic, the input is read by the DP slaves while the output is transferred to the DP slaves.

After an error has occurred during the data transfer phase of the DPM1, like for example, the failure of a DP slave, the response of the system is determined by the operating parameter "Auto Clear".

If this parameter has been set to true, the DPM1 will set the output of all the respective DP slaves to the safe status, as soon as a DP slave is no longer available for user data communication. Afterwards, the DPM1 changes to the clear status.

If this parameter is = false, the DPM1 remains, even if an error occurs, in the operate status, and the user can determine the response of the system at his own discretion.

CYCLICAL DATA TRANSFER BETWEEN DPM1 AND THE DP SLAVES

The data traffic between the DPM1 and the respective DP slaves is automatically handled by the DPM1 in a fixed, recurring order. When configuring the bus system, the user assigns a DP slave to the DPM1. In addition, the slaves to be included in- or excluded from the user data communication are defined.

The data traffic between the DPM1 and the DP slaves is subdivided in parametrisation, configuration, and data transfer phases. Before including a DP slave in the data transfer phase, the DPM1 checks during the parametrisation and configuration phase, whether the planned set configuration corresponds to the actual configuration of the device.

For this check, the device type, the information on the format and the length as well as the number of input and output lines have to be correct. The user thus obtains a reliable protection against parametrisation errors. In addition to the user communication, which is automatically executed by the DPM1, the user may request the new parametrisation data to be sent to the DP slaves.

Basics of Absolute Encoders ACURO

Profibus-DP

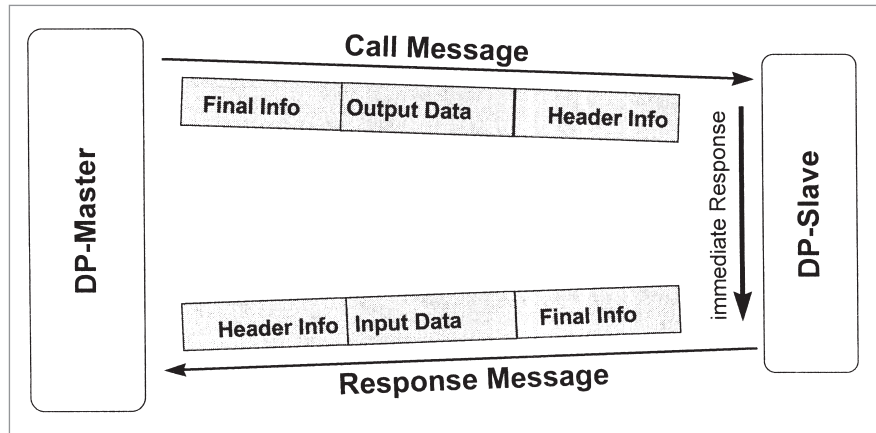

User data communication for PROFIBUS-DP

DATA TRAFFIC BETWEEN DPM1 AND PROJECT PLANNING DEVICES

In addition to the functions between DP master and DP slaves, master-master communication functions are available, see table. They support the project planning and diagnostic devices in projecting the system via the bus.

Besides the upload and download functions, the master-master functions offer the opportunity to switch the user data transfer between the DPM1 and the single DP slaves dynamically on or off as well as to modify the operating status of the DPM1.

Function	Meaning	DPM1	DPM2
Get_master_Diag	reads the diagnostic data of the DPM1 or the collective diagnosis of the DP slaves.	M	0
Download / Upload Group (Start_Seq, Down-/Upload, End_Seq)	reads or writes the entire configuration data of a DPM1 and of the respective DP slaves.	0	0
Act_Para_Brct	activates the bus parameters for all operating DPM1 devices.	0	0
Act_Param	activates parameters or modifies the operating status of the operating DPM1 device.	0	0

M: mandatory, 0: optional

Functional overview for the master-master functions for PROFIBUS DP

Profibus-DP

SYNC MODE

In addition to the station-related user data communication being automatically handled by the DPM1, the masters may send control commands to a single slave, a group of slaves or all slaves at the same time. These control commands are transferred as multicast. It is only by means of this multicast that the sync and freeze operating modes for the event-controlled synchronisation of the DP slaves have been enabled.

The sync mode is started by the slaves, as soon as they receive a sync command from the respective master. The output lines of the addressed slaves will then be frozen in their current state. The output data will be stored at the slaves during the following user data transfers; the state of the output lines, however, will remain unchanged. Unless the next sync command has been received, the stored output data will not be connected to the output lines. By selecting unsync, the sync mode is terminated.

PROTECTIVE MECHANISMS

For reasons of safety, it is necessary to equip PROFIBUS DP with powerful protective functions against false parametrisation or failure of the transmission equipment. For this purpose, control mechanisms at the DP master and the DP slave have been realised, taking the form of time-out circuits. The monitoring interval is determined during project planning.

At the DP master

The DPM1 controls the data traffic of the slaves by means of the Data_Control_Timer. For each slave, a special timer is used. The time-out circuit will respond, if no proper user data transfer occurs during a control interval. In this case, the user will be informed. If the automatic response to an error (Auto_Clear = True) has been released, the DPM1 will quit the operate status, switch the output lines of the respective slaves to the safe status and change to the clear status.

At the DP slave

In order to recognise errors by the master or transmission errors, the slave executes the response control. If there is no data traffic during the response control interval, the slave will automatically switch the output lines to the safe status.

When operating in multimaster systems, a supplementary access protection for the I/O lines of the slaves will be necessary. This is to make sure that direct access can only be gained by an authorised master. For all the other masters, the slaves will provide an I/O map which can be also be read without access authorisation.

COMMUNICATION INTERFACE

The communication interface corresponds to the PROFIBUS DP class 2 encoder profile.

Within this interface the class 1 functions are included.



For further information see:
www.profibus.de

Glossary of Technical Terms

Absolute shaft encoder	Shaft encoder that transmits unique coded data for each increment.
Accuracy	The difference between the actual and measured position.
Alarm signal	Serves to monitor the shaft encoder for malfunctions, such as glass breakage, fouling, short circuit, short circuit of signal line, and supply voltage too low.
Amplitude regulation	Current or voltage amplitude is constant through regulation
Analogue signal	A signal whose level alters continuously.
ASIC	Application specific integrated circuit
Axial loading	Maximum load on the shaft encoder's shaft in the axial direction
Bandwidth	Frequency range for output signals
Baud rate	Rate of data transfer (bits per second).
BCD	Binary-coded decimal; binary representation of a decimal number.
Binary	Two logical states (yes/no); the basis of binary data-processing systems.
Binary code	Code using binary numbering; often used for absolute measuring systems.
Bit	Abbreviation for "binary digit"; the smallest unit of information of a binary system, whose value can be 1 or 0 (yes-or-no decision).
Bus cycle	Time needed for polling every bus slave by the bus master.
Byte	Sequence of 8 Bits.
CAL	Can application layer
CANopen	Layer 7 protocol based on CAN
CCW	Counter clockwise
Change of state	For CAN: Bus node (encoder) sends it's data automatically when a position change occurs.
Channel	Signal track on which 1 or 0 is outputted.
CiA	CAN in automation (CAN users and manufacturers group)
CiA DS	CAN in automation draft standard, communication profile
CiA DSP	CAN in automation draft standard proposal, communication profile
CIM	Computer Integrated Manufacturing; i. e. the linking of different computer-aided processes in production and related fields for general use of the data.
CMD	Software tool for configuration and diagnosis of Interbus networks
COB	Communication object
Code	Format in which data are transmitted.
Code switching frequency	Number of position steps per second. For absolute shaft encoders with parallel interface: The maximum output frequency of the LSB output driver (f_{max}) also limits the maximum permissible code switching frequency: Code switching frequency max. = $2 \cdot f_{max}$ for Binary code Code switching frequency max. = $4 \cdot f_{max}$ for Gray code

Glossary of Technical Terms

Coefficient of thermal expansion	Material expansion under influence of temperature change [$\mu\text{m}/^\circ\text{K m}$], relevant for linear scales.
Complementary	Output circuit for which also the inverted signals are outputted (e.g. Channel A and Channel A). Electrically, the 1/0 levels are transmitted as voltage differences between two lines. In this way the information signal (the difference) remains pure as in general interferences are interspersed equally on both lines.
CRC	Cyclic redundancy check. Bit error protection method for data communication.
CW	Clockwise
Data bus	System of lines over which data are transferred electronically in parallel or serially.
Data consistency	Intrinsic coherence of data in respect of timing and logical aspects.
Data integrity	Correspondence of data with the reality that they describe.
Datavalid	Output for checking the validity of data.
DC	Direct current (not alternating)
Demodulator	Device that filters the original information out of an altered signal again.
DeviceNet - conformity and interoperability	Confirmation of agreement of a bus node with the DeviceNet specifications and correct interoperability with other DeviceNet nodes.
Differential line driver	Output circuit in which the difference between the two signals A and A is evaluated, thus providing high signal transmission reliability.
DIN	Deutsche Industrie Norm (German Industrial Standard)
Direction	Control input for determining the data sequence (whether ascending for clockwise or counterclockwise rotation).
Dual Code	Natural binary code
EDS - File	Electronic data sheet. This is a file with the device specific parameter description and is provided by the manufacturer of a DeviceNet or CANopen device.
EEPROM	"Electrically Erasable Programmable Read-Only Memory" chip (see EPROM).
EIA	Electronic Industries Association; U.S. umbrella organization of manufacturers of electronic equipment and facilities. It is responsible for maintenance and development of the industrial standards for interfaces between data-processing devices and data communications equipment.
EMC	Electromagnetic compatibility
ENCOM	User group of manufacturers of INTERBUS-S absolute shaft encoders
Encoder monitoring	See "Alarm signal"
Enable	Control input via which the data outputs can be activated.
Encoder power	Supply voltage to be provided for the shaft encoder.
EPROM	"Erasable Programmable Read-Only Memory" chip, which can be erased with ultraviolet light, after which new data can be written into it.
Gray code	A special binary code that changes only one data bit per measuring step at a time. It is used with absolute encoders.

Glossary of Technical Terms

Hamming distance	Measure for data security in a data transmission. The higher the number the better the ability to detect data errors.																												
Harmonic Distortion	Measure for the signal quality of sinewave encoder [%]. It describes the content of harmonics in analogue signals. The lower the number the better the signal.																												
Hysteresis error	Measurement deviation for a position approached from opposite directions.																												
Identifier	Address of a message in a CAN network.																												
IEC	International Electrotechnical Commission; organization promoting international standardization of electrical components.																												
Immunity to interference	<p>Test procedure according to IEC 801, Part 4</p> <p>– A test of susceptibility to fast electrical transients (bursts) causing interference on lines.</p> <p>The test values are divided into 5 levels:</p> <table border="1"> <thead> <tr> <th>Level</th> <th>Mains line</th> <th>Data and control lines</th> </tr> </thead> <tbody> <tr> <td>1</td> <td>0.5 kV</td> <td>0.25 kV</td> </tr> <tr> <td>2</td> <td>1.0 kV</td> <td>0.5 kV</td> </tr> <tr> <td>3</td> <td>2.0 kV</td> <td>1.0 kV</td> </tr> <tr> <td>4</td> <td>4.0 kV</td> <td>2.0 kV</td> </tr> <tr> <td>X</td> <td>special</td> <td>special</td> </tr> </tbody> </table> <p>– Test procedure according to IEC 801, Part 2</p> <p>Discharge of static electricity on the surface and in the surroundings of the specimen. The test values are divided into 4 classes:</p> <table border="1"> <thead> <tr> <th>Class</th> <th>test voltage</th> </tr> </thead> <tbody> <tr> <td>1</td> <td>2 kV</td> </tr> <tr> <td>2</td> <td>4 kV</td> </tr> <tr> <td>3</td> <td>8 kV</td> </tr> <tr> <td>4</td> <td>15 kV</td> </tr> </tbody> </table> <p>– Radio interference voltage test to VDE 0871.</p>	Level	Mains line	Data and control lines	1	0.5 kV	0.25 kV	2	1.0 kV	0.5 kV	3	2.0 kV	1.0 kV	4	4.0 kV	2.0 kV	X	special	special	Class	test voltage	1	2 kV	2	4 kV	3	8 kV	4	15 kV
Level	Mains line	Data and control lines																											
1	0.5 kV	0.25 kV																											
2	1.0 kV	0.5 kV																											
3	2.0 kV	1.0 kV																											
4	4.0 kV	2.0 kV																											
X	special	special																											
Class	test voltage																												
1	2 kV																												
2	4 kV																												
3	8 kV																												
4	15 kV																												
Incremental measuring system	Measuring method in which the variable is formed by counting increments (measuring steps).																												
Incremental shaft encoder	Shaft encoder which transmits an electrical signal (yes/no) for each increment, determined by the marked disc.																												
Integer	Integral values; range of values at n bit: 0 ... (2 ⁿ -1)																												
Integrated coupling	Flexible coupling built into shaft encoders																												
INTERBUS	Real time bus for the sensor-actor-level																												
Interbus-Loop	Two wire version of Interbus, transmitting data over the power supply lines and using Phoenix Contact "Quickon" cable plugs.																												
Interface	Transfer point with certain terminals, signals, or signal sequences. The interface serves for communication of the shaft encoder with other systems.																												
Interpolation	Scanning of a sinewave signal to increase resolution by generating intermediate position values.																												
IP	See "Protection class"																												
Jitter	Change in the phase angle between Channel A and B within one revolution (360°).																												
Latch	Control input for storing ("freezing") the data before they are read out.																												

Glossary of Technical Terms

Linearity	Deviation of the reading from the actual value within one revolution (360°).																												
Line driver	Output circuit that makes a larger current possible.																												
LSB	Least Significant Bit																												
Measuring wheel	A wheel that, mounted on a shaft encoder, converts a linear motion into a rotary motion.																												
MSB	Most Significant Bit																												
MTBF	"Mean Time Between Failures", a measure of average service life.																												
Multi-turn shaft encoder	Shaft encoder which transmits the number of shaft revolutions as well as the angular position of the shaft.																												
NC machinery	Numerically Controlled machinery; their movements are programmed.																												
NPN input/output	Transistor input/output circuit implemented with an npn transistor, and thus negative switching.																												
Offset	For programmable absolute shaft encoders: the offset value is added to the value of physical position. As a result you get a relative shift of the output value (output value = position value + offset value).																												
Parallel interface	Transfer point at which the data are transferred in parallel over several lines.																												
Parity	Checkbit for error detection in data transfer																												
PDO	Process data object (in CAN networks)																												
P.L.C.	Programmable Logic Controller: control system whose program is stored in a program memory and can be changed.																												
Phase discriminator	Sense-of-direction detector that functions by evaluating the phase angle between Signal A and Signal B.																												
Phase tolerance	Deviation of the pulse-edge from Channel A to B, relative to the phase angle 90°.																												
PNP input/output	Transistor input/output circuit implemented with a pnp transistor, and thus positive switching.																												
Preset	For programmable absolute shaft encoders: The programmed numerical value is accepted as output value (output value = preset value).																												
Protection class	<p>The enclosure class is designated according to DIN 40050, by IP and a two-figure code number.</p> <table> <tr> <td>1st digit</td> <td>Degree of protection against ingress of solid bodies:</td> </tr> <tr> <td>0</td> <td>no special protection</td> </tr> <tr> <td>1</td> <td>solid bodies with dia. > 50 mm, no protection against intentional penetration</td> </tr> <tr> <td>2</td> <td>solid bodies with dia. > 12 mm, warding off fingers etc.</td> </tr> <tr> <td>3</td> <td>solid bodies with dia. > 2.5 mm, warding off tools, wires, etc. (thickness > 2.5 mm)</td> </tr> <tr> <td>4</td> <td>solid bodies with dia. > 1 mm, warding off tools, wires, etc. (thickness > 1 mm)</td> </tr> <tr> <td>5</td> <td>dust in harmful quantities, complete shock-hazard protection</td> </tr> <tr> <td>6</td> <td>dust (dust-tight), complete shock-hazard protection</td> </tr> <tr> <td>2nd digit</td> <td>Degree of protection against water</td> </tr> <tr> <td>0</td> <td>no special protection</td> </tr> <tr> <td>1</td> <td>water dripping vertically</td> </tr> <tr> <td>2</td> <td>water dripping at angles up to 15° from vertical</td> </tr> <tr> <td>3</td> <td>water dripping at angles up to 60° from vertical (spraying water)</td> </tr> <tr> <td>4</td> <td>water from all directions (splashing water)</td> </tr> </table>	1st digit	Degree of protection against ingress of solid bodies:	0	no special protection	1	solid bodies with dia. > 50 mm, no protection against intentional penetration	2	solid bodies with dia. > 12 mm, warding off fingers etc.	3	solid bodies with dia. > 2.5 mm, warding off tools, wires, etc. (thickness > 2.5 mm)	4	solid bodies with dia. > 1 mm, warding off tools, wires, etc. (thickness > 1 mm)	5	dust in harmful quantities, complete shock-hazard protection	6	dust (dust-tight), complete shock-hazard protection	2nd digit	Degree of protection against water	0	no special protection	1	water dripping vertically	2	water dripping at angles up to 15° from vertical	3	water dripping at angles up to 60° from vertical (spraying water)	4	water from all directions (splashing water)
1st digit	Degree of protection against ingress of solid bodies:																												
0	no special protection																												
1	solid bodies with dia. > 50 mm, no protection against intentional penetration																												
2	solid bodies with dia. > 12 mm, warding off fingers etc.																												
3	solid bodies with dia. > 2.5 mm, warding off tools, wires, etc. (thickness > 2.5 mm)																												
4	solid bodies with dia. > 1 mm, warding off tools, wires, etc. (thickness > 1 mm)																												
5	dust in harmful quantities, complete shock-hazard protection																												
6	dust (dust-tight), complete shock-hazard protection																												
2nd digit	Degree of protection against water																												
0	no special protection																												
1	water dripping vertically																												
2	water dripping at angles up to 15° from vertical																												
3	water dripping at angles up to 60° from vertical (spraying water)																												
4	water from all directions (splashing water)																												

Glossary of Technical Terms

Protection class (continued)	<p>2nd digit Degree of protection against water</p> <p>5 water from a nozzle from all directions (hose-water)</p> <p>6 heavy seas or strong jet of water (flooding)</p> <p>7 water, if the device is immersed in water under specified conditions of pressure and time (immersion)</p> <p>8 water, if the device is submerged constantly. The manufacturer must describe the conditions (submersion)</p> <p>(For numbers 1 to 8, water must not penetrate in harmful quantities.)</p> <p>Example: IP65 A device thus designated is dust-tight, and protected against hose-water.</p>
PVC	Polyvinylchloride; plastic coating of device cable
PTB approval	Approval for use by the Physikalisch-Technische Bundesanstalt, the German government materials testing institute.
Pulse (repetition) frequency, max. speed	The maximum signal frequency achievable by the shaft encoder, the product of rotary and number of markings.
Radial load, max.	Maximum loading of shaft encoder shaft in radial direction.
Quickon	Connector with self contacting cable cutting contacts from Phoenix Contact used with Interbus Loop
RAM	"Random Access Memory" chip; this memory can be read from, written to, and erased freely. When the power goes off, it loses its information.
Reference mark	Irregular gradation pattern that generates a single signal peak, to provide an absolute reference for an incremental shaft encoder.
Reference pulse	Square-wave signal generated by a reference mark, usually only one increment wide, to provide an absolute reference for an incremental shaft encoder.
Repeatability	Degree of deviation for a point approached repeatedly under identical operating conditions.
Resolution	Number of increments per revolution (rotary) or distance between two increments (linear)
Resolver	Inductive angular measuring device that generates two alternating voltages, with amplitude a function of the angle.
Reversal error	Deviation in reading of a position when approached from different directions (hysteresis).
ROM	"Read-Only-Memory" chip, whose memory can only be read out.
RS 422	Standardized interface for unidirectional point-to-point connections (for description refer to "Complementary"); voltage difference 7 V DC max.
RS 422/485	Interfaces for serial data transfer with specifications to EIA standards.
RS 485	Like RS 422, however as a bidirectional bus interface
Sampling frequency	Number of signal periods per second. The maximum sampling frequency limits the speed of incremental measuring systems.
SDO	Service data object (in CAN networks)
Sense	The Sense lines (Sense VCC and Sense GND) enable measurement of the factual encoder voltage without adulteration by voltage drop due to supply current and cable resistivity. With that e.g. supply voltage can automatically be adjusted.

Glossary of Technical Terms

Scaling	For programmable absolute shaft encoders the encoder actual value is multiplied by a scaling factor. Thus the resolution (increments per measuring distance or increments per revolution) is adaptable to the respective application.
SSI	Synchronous-serial Interface; standardized interface for serial data transfer
TPE	Thermo-plastic polyester elastomer; plastic coating of device cable
Tristate	Control input; switches the outputs either to active or to high impedance.
Two's complement	Number format for the representation of negative numbers; range of values at n bit: $-(2^n - 1) \dots 0 \dots (2^{n-1} - 1)$

Sales and Service international

Argentina	Zeising y Cia. S.A. Perú 245, C.P. (C1067AAE) Buenos Aires Tel. (5411) 4345-2321 Fax (5411) 4331-6291 zeising@ssdnet.com.ar http://www.zeising.com.ar/	China	Automate Control Engineering Ltd. Room G, 16/F., No.1 Building, No. 445, Tian He Bei Road, Guangzhou Guangdong Province. Tel: (020) 38845119 Fax: (020) 38823577 guangzhou@automate-ace.com www.automate-ace.com	Great Britain	West Instruments The Hyde Brighton, East Sussex BN2 4JU, England Tel. +44 (0) 1273 606271 Fax +44 (0) 1273 609990 info@west-inst.co.uk http://www.west-inst.co.uk
Australia	Automated Control Engineering Group Pty Ltd. Unit 1, 64 Munibung Road Cardiff NSW 2285 Tel. +61-2- 4954 5004 Fax +61-2- 4956 7686 phil@aceg.com.au http://www.aceg.com.au/		Automate Control Engineering Ltd. 702 room, Tower 9 , No 228 Guangxi North Road, Huangpu Borough, Shanghai Tel: (021) 63526529, 63526539 Fax: (021) 63508015 shanghai@automate-ace.com www.automate-ace.com	Greece	Control System Ltd. 13 Chlois st 546 27 Thessaloniki Tel. (031) 527228 Fax (031) 515495 info@controlsystem.gr
Austria	Tischer Handels GmbH Industriestr. 23 A-2353 Guntramsdorf Tel. 0043-(0) 2236-89 3323-0 Fax 0043-(0) 2236-893323-40 office@tischer.at Mobil: 0043-676-7503925		Beijing Westman Automation Technology Lt. Co Room 1207, Xuezhixuan Building No. 16 Xueqing Road Haidian District Beijing 100083 PR China Tel: 86-10-82755948 Fax: 86-10-82755951 sales@westmaninc.com	Hong Kong	Automate Control Engineering Ltd Unit 1505 Entrepot Centre, 117 How Ming Street, Kwun Tong, Kowloon, Hong Kong Tel: 852-2342-7276 Fax: 852-2342-7229 ace@automate.corp.com.hk
Belgium	Geveke Industrial Belgium Leuvensesteenweg 250 A 1800 Vilvoorde Tel. 0032-2257.02.40 Fax 0032-2257.02.49 info@geveke.be http://www.geveke-industrial.be/	Czech Republic	SETRON, s.r.o. K Mejtu 11 142 00 Praha 4-Plsnice Tel. 00420-2-619 10 222 Fax 00420-2-619 10 225 Mobil: 00420-601-211 355 setron@setron.cz http://www.setron.cz - not for "Printers"	Hungary	C+D Automatika KFT Postfach 156 1701 Budapest Tel. (0036) 1 2829 896 Fax (0036) 1 2823 125 cdaut@e-mail.inext.hu http://www.cdaut.hu/
Brasil	Veeder Root do Brasil Com. e. Ind. Ltda. Rua Ado Benatti, 92 Sao Paulo SP CEP 05037-904 Tel. 5511 861-2155 Fax 5511 861-1982 Antonio_Araujo@veeder.com	Denmark	Carlo Gavazzi Handel A/S Over Hadstenvej 42 8370 Hadsten Tel. 0045-89 60 61 00 Fax 0045-86 98 1 530 handel@gavazzi.dk www.carlogavazzi.com	India	Proximon Controls Pvt. Ltd. 202, Krishna Laxmi Industrial Complex Pokhran Road No. 1 Vartak Nagar Thane - 400 606 Tel. 91 -22 - 2588 92 44 / 45 91- 22 - 2585 42 87 Fax. 91-22 - 2588 92 46 proximon@vsnl.com http://www.proximon.com/
Chile	Vignola y Cia. Ltda. P.O. Box 93-V CPIO-Subida El Peral 25 Valparaiso Tel. 0056-3225-6521 Fax 0056-3225-8571 vignola@entelechile.net	Finland	Sensorola Oy Vanha Porvoontie 229 01380 Vantaa Tel. 0358-9-8386460 Fax 0358-9-8572205 myynti@sensorola.fi http://www.sensorola.fi/	India	<i>North India Territory:</i> Kudamm Corporation D-17, IInd Floor, Kalkaji Opp.Nehru Place Bus Terminal New Delhi -110019, India Tel: 91-11-26423028 Fax: 91-11-26479097 Email: kudamm@vsnl.com www.kudammcorp.com
China	Hengstler GmbH - Shanghai Office Room 904, Tower 1 Shanghai Kerry Everbright City No 218 Tian Mu Road West Shanghai 200070 China Tel: 86-21-33030472 Fax: 86-21-33030345 hengstler.ty@tom.com Hengstler GmbH - Beijing Office Room 2202, Scitech Tower 22 Jianguomen Wai Street Beijing 100004 PR China Tel: 86-10-6512-0195 Fax: 86-10-6522-0887 frankli@sohu.net	France	Hengstler Contrôle Numérique SARL Z.I. des Mardelles 94-106 Rue Blaise Pascal, B.P. 71 93602 Aulnay-sous-Bois, Cédex Tel. (01) 48795501 Fax (01) 48795561 http://www.hengstler.fr	Indonesia	Anugerah Abadi Hayam Wuruk Indah Lindevetes Lantai Dasar Blok DKS No. 82 Jakarta - Jl. Hayam Wuruk Tel.+ Fax: 0062216255561 iwanb@centrin.net.id
		Guatemala	Impex Ltda. 1a Avda. 10-81 Zona 10 8é Nivel Ciudad de Guatemala Tel. 502 332 7432 Fax 502 332 7431 impex@newcomgua.com	Israel	Albas Electronics Ltd. 1 Hanofar Str. 43662 Raanana Tel.: +97 297458880 Fax: +97 297458881

Sales and Service international

Italia	ICG Holding S.r.l. Via Leonardo da Vinci, 45/47 20020 Lainate (MI) Tel. 0039-02 9330011 Fax 0039-02 933001299 info@icg-holding.com	Netherlands	Geveke Industrial De Meerheuvel 6a 5221 EA 's-Hertogenbosch Postbus 2232 5202 CE's Hertogenbosch Tel. +31-(0) 73-6391639 Fax +31-(0) 73-6391699 info@gjn.geveke.nl http://www.geveke-industrial.nl/	Singapore	Danaher Industrial Controls Group Singapore 246 MacPherson Road #08-01 Betime Building Singapore 348578 Tel. 65-6-7459265, Fax 65-6-7461791 Pager: 94158924 fredtay@singnet.com.sg
Japan	Danaher ICG Japan Co. Ltd. 1-8-5, Asagayaminami Suginami-Ku Tokyo 166-0004 Tel. (03) 5306-0150 Fax (03) 5306-0160 Danaher ICG Japan Co. Ltd. 2-12-23, Minamikaneden Suita-shi Osaka 564-0044 Tel. (06) 6386-8001 Fax (06) 6386-5022 e-mailmaster@danaher.co.jp	New Zealand	EMC Industrial Group Ltd. P.O. Box 101444 NSMC, Auckland Tel. (09) 415 5110 Fax (09) 415 5115 sales@emc.co.nz		TDS Technology (S) Pte Ltd. 4 Sungei Kadut Loop (HOCEN Building, 3rd. Storey) Singapore 729493 Tel. (65) 366 1661 Fax (65) 362 1661 sales@tdstech.com http://www.tdstech.com/
		Norway	Hecotron Industriell Elektronik AS Postboks 4269, Torshöv Gunnar Schjelderupsv.9 04001 Oslo Tel. (22) 159 615 Fax (22) 22 93 65 hecotron@hecotron.no www.hecotron.no	Slovenia	TIPTEH D.O.O. Ulica Ivana Roba 21 1000 Ljubljana Tel. (061) 200 51 50 Fax (061) 200 51 51 damijan.jager@abm.si http://www.tipteh.si
Korea	Dae-Hyun Sangong Co., Ltd Room No.B-607, Woolimmm Lions Valley. #371-62, Gasan-Dong, Geumcheon-Gu Seoul, Korea Tel. 0082-2-206-4321 Fax 0082-2-206-4322 cyberist@shinbiro.com Wooil Engineering Room # 805, 302dong Bucheon Techno park, 365 Samjeongdong Ojeong-gu, Bucheon-si Kyunggi-do KOREA Tel: 82-2-652-5622 Fax: 82-2-652-5624 wooil@murr.co.kr www.murr.co.kr	Norway	<i>Only for Controllers:</i> Carlo Gavazzi AS P.O. Box 215 3901 Porsgrunn Tel. 0047-35 93 08 00 Fax 0047-35 93 08 01 obe@carlo gavazzi.no http://productsonline.info	South Africa	Countapulse Controls (Pty) Ltd. Cleveland, 2022 P.O. Box 40393 313 Jules Street Malvern, 2094 Tel. (011) 615 7556/7/8 Fax (011) 615 7513 countap@iafrica.com
		Peru	Ing. E. Brammertz S.C.R.L. Apdo. 0173 Miraflores-Lima 18 Tel. +51-1-445 81 78 Fax +51-1-445 01 81 braming@mail.cosapidata.com.pe	Spain	Carlo Gavazzi, S.A. Ava. Iparraquirre, 80-82 48940 Leioa (Bizkaia) Tel. 0034-94-480 40 37 Fax 0034-94-480 10 61 gavazzi@carlo gavazzi-sa.es http://www.carlogavazzi.com/ac/es
Lebanon	Incotel Electronics Facing Dora Gate Beirut Tel. 00961-1-240003 Fax 00961-1-252276 incotel@cyberia.net.lb www.incotel.com	Philippines	JMTI Industrial Corporation RM 203 Comfoods Building Sen. Gil Puyat Ave. Makati Metro Manila Tel. 0063-32-8446326 Fax 0063-32-3460763 jmti@info.com.ph	Sweden	ACUMO AB Hans Stahles väg S-14741 Tumba Tel. +46 8 53065840 Fax. +46 8 53034750 info@acumo.se http:// www.acumo.se
Luxemburg	→ Belgium	Poland	Eltron pl.Wolnosci 7 B 50-071 Wroclaw Tel. 0048-71-343 97 55 Fax 0048-71-344 11 41 GF@eltron.pl www.eltron.pl	Switzerland	Digana AG Rotackerstrasse 21 8304 Wallisellen Tel. (01) 8300893 Fax (01) 8300807 Info@digana.ch http://www.digana.ch/
Malaysia	FEG Components Sdn Bhd No. 6-2, (1st Floor), Jalan USJ 9/5N Subang Business Centre, UEP Subang Jaya 47620 Subang Jaya, Selangor Tel. 60-3-7245748 Fax 60-3-7245766 mg.chan@farnell-electronic.com	Portugal	Carlo Gavazzi Lda Rua dos Jeronimos 38-B 1400-212 Lisboa Tel. +351 21 361 70 60 Fax +351 21 362 13 73 carlogavazzi@carlo gavazzi.pt		
Mexico	Comp. Ferretera Mexicana S.A. de CV. 16 de Septiembre No. 58 Apartado Postal 148 06000 Mexico, D.F. Tel. 0052-55-5518-4930 Tel. 0052-55-5512-2400 Fax 0052-55-5521-1707 bokersa@data.net.mx				

Sales and Service international

Taiwan	<p>King-E Lu Ltd. R. o. C. 10F-3, No. 20 Min Chuan West Road P.O. Box 68-118 118 Taipei Tel. (02) 25223056 Fax (02) 25319692 king.e@seed.net.tw</p> <p><i>Distributor:</i> Rotech Enterprise Co. Ltd. 6F, No. 3, Lane 26, Kuang-Fu N. Road Taipei Tel : 886-2-25781261 Fax : 886-2-25784348 E-KawaKami@tpts5.seed.net.tw</p>	USA	<p>Danaher Controls 1675 Delaney Road Gurnee, IL 60031-1282 Tel. (847) 662.2666 Fax (847) 662.6633 dancon@dancon.com http://www.dancon.com/</p> <p>Danaher Controls 2100 W. Broad Street Elisabethtown, NC 28337 Tel. 910-862 2511 Fax 910 862 5400 http://www.dancon.com/</p> <p>HECON 2100 West Broad Street P.O. Box 368 Elizabethtown, NC 28337 Tel. 910.879.5493 Fax 910.862.5408 info.hecon@hecon.com http://www.hecon.com <i>- only for Printers + Cutters</i></p>
Thailand	<p>Industrial Electrical Co., Ltd. 85/2, 85/3 Soi Sot Phin San Rang Nam Road, Rajthevee 10400 Bangkok Tel. 66-2-642-6700 Fax 66-2-642-4250 iecl@ie.co.th http://www.ie.co.th/</p>	Venezuela	<p>Victor Rafael Escobar + CA. Apartado de Correos, 50 113 Caracas-1050-A Tel. (02) 715235/729059 Fax (02) 7629059</p>
Turkey	<p>Arslan Elektronik Doz. Dipl.-Ing. Osman Arslan Lüleci Hendek Caddesi No. 47 80020 Karaköy-Istanbul Tel. 0212-2434627-2493134-292577 Fax 0212-251 8385 arslanelo@softhome.net http://abone.turk.net/arslane</p>	Vietnam	<p>Hoang Quoc Co. Ltd. 509 Kimma Str. Badinh District Hanoi-S.R.Vietnam Tel: 0084-4-8317421 Fax: 0084-4-8317433 hoangquoc@hn.vnn.vn</p>
U.A.E. United Arab Emirates	<p>Descon Trading L.L.C P.O. Box 14675 Dubai Tel. 00971-4-2653651 Fax 00971-4-2653264 basusil@emirates.net.ae</p>		

GENERAL CONDITIONS

FOR THE SUPPLY OF PRODUCTS AND SERVICES OF THE ELECTRICAL AND ELECTRONICS INDUSTRY*

for commercial transactions between businesses

– January 2002 –

I. GENERAL

1. The scope of deliveries and/or services (hereinafter referred to as „Supplies“) shall be determined by the written declarations of both Parties. General terms and conditions of the Purchaser shall apply only if and when expressly accepted by the supplier or the provider of services (hereinafter referred to as „Supplier“) in writing.
2. The Supplier herewith reserves any industrial property rights and/or copyrights pertaining to its cost estimates, drawings and other documents (hereinafter referred to as „Documents“). The Documents shall not be made accessible to third parties without the Supplier's prior consent and shall, upon request, be returned without undue delay to the Supplier if the contract is not awarded to the Supplier. Sentences 1 and 2 shall apply mutatis mutandis to documents of the Purchaser; these may, however, be made accessible to third parties to whom the Supplier may rightfully transfer Supplies.
3. The Purchaser shall have the non-exclusive right to use standard software, provided that it remains unchanged, is used within the agreed performance parameters, and on the agreed equipment. The Purchaser may make one back-up copy without express agreement.
4. Partial Supplies shall be allowed, unless they are unreasonable to accept for the Purchaser.

II. PRICES AND TERMS OF PAYMENT

1. Prices shall be ex works and exclude packaging; value added tax shall be added at the then applicable rate.
2. If the Supplier is also responsible for assembly or erection and unless otherwise agreed, the Purchaser shall pay the agreed remuneration and any incidental costs required, e. g. travel costs, costs for the transport of tools and equipment, and personal luggage as well as allowances.
3. Payments shall be made free Supplier's paying office.
4. The Purchaser may set off only those claims that are undisputed or against which no legal recourse is possible.

III. RETENTION OF TITLE

1. Items pertaining to the Supplies („Retained Goods“) shall remain the property of the Supplier until each and every claim the Supplier has against the Purchaser on account of the business connection has been fulfilled. If the combined value of the security interests of the Supplier exceeds the value of all secured claims by more than 20 %, the Supplier shall release a corresponding part of the security interest if so requested by the Purchaser.
2. For the duration of the retention of title, the Purchaser may not pledge the Retained Goods or use them as security, and resale shall be possible only for resellers in the ordinary course of their business and only on condition that the reseller receives payment from its customer or makes the transfer of property to the customer dependent upon the customer fulfilling its obligation to effect payment.
3. The Purchaser shall inform the Supplier forthwith of any seizure or other act of intervention by third parties.
4. Where the Purchaser fails to fulfil its duties, including failure to make payments due, the Supplier shall be entitled to cancel the contract and take back the Retained Goods in the case of continued failure following expiry of a reasonable time set by the Supplier; the statutory provisions that a time limit is not needed remain unaffected. The Purchaser shall be obliged to surrender the Retained Goods.

IV. TIME FOR SUPPLIES; DELAY

1. Times set for Supplies can only be observed if all Documents to be supplied by the Purchaser, necessary permits and releases, especially concerning plans, are received in time and if agreed terms of payment and other obligations of the Purchaser are fulfilled. Unless these conditions are fulfilled in time, times set shall be extended appropriately; this shall not apply where the Supplier is responsible for the delay.
2. If non-observance of the times set is due to force majeure such as mobilization, war, rebellion or similar events, e. g. strike or lockout, such time shall be extended accordingly.
3. If the Supplier is responsible for the delay (hereinafter referred to as „Delay“) and the Purchaser demonstrably suffered a loss therefrom, the Purchaser

may claim a compensation as liquidated damages of 0.5 % for every completed week of Delay, but in no case more than a total of 5 % of the price of that part of the Supplies which because of the Delay could not be put to the intended use.

4. Purchaser's claims for damages due to delayed Supplies as well as claims for damages in lieu of performance exceeding the limits specified in No. 3 above shall be excluded in all cases of delayed Supplies even upon expiry of a time set to the Supplier to effect the Supplies. This shall not apply in cases of mandatory liability based on intent, gross negligence, or due to injury of life, body or health. Cancellation of the contract by the Purchaser based on statute shall be limited to cases where the Supplier is responsible for the delay. The above provisions do not imply a change in the burden of proof to the detriment of the Purchaser.
5. At the Supplier's request the Purchaser shall declare within a reasonable period of time whether the Purchaser cancels the contract due to the delayed Supplies or insists on the Supplies to be carried out.
6. If dispatch or shipment is delayed at the Purchaser's request by more than one month after notice of the readiness for dispatch was given, the Purchaser may be charged, for every month commenced, storage costs of 0.5 % of the price of the items of the Supplies, but in no case more than a total of 5 %. The parties to the contract may prove that higher or, as the case may be, lower storage costs have been incurred.

V. TRANSFER OF RISK

1. Even where delivery has been agreed freight free, the risk shall pass to the Purchaser as follows:
 - a) if the Supplies do not include assembly or erection, at the time when the Supplies are shipped or picked up by the carrier. Upon request of the Purchaser, the Supplier shall insure the Supplies against the usual risks of transport at the expense of the Purchaser;
 - b) if the Supplies include assembly or erection, at the day of taking over in the own works or, if so agreed, after a fault-free trial run.
2. The risk shall pass to the Purchaser if dispatch, shipping, the start or performance of assembly or erection, the taking over in the own works or the trial run is delayed for reasons for which the Purchaser is responsible or if the Purchaser has otherwise failed to accept the Supplies.

VI. ASSEMBLY AND ERECTION

Unless otherwise agreed in writing, assembly/erection shall be subject to the following provisions:

1. The Purchaser shall provide at its own expense and in good time:
 - a) all earth and construction work and other ancillary work outside the scope of the Supplier, including the necessary skilled and unskilled labour, construction materials and tools,
 - b) the equipment and materials necessary for assembly and commissioning such as scaffolds, lifting equipment and other devices as well as fuels and lubricants,
 - c) energy and water at the point of use including connections, heating and lighting,
 - d) suitable dry and lockable rooms of sufficient size adjacent to the site for the storage of machine parts, apparatus, materials, tools, etc. and adequate working and recreation rooms for the erection personnel, including sanitary facilities as are appropriate in the specific circumstances. Furthermore, the Purchaser shall take all measures it would take for the protection of its own possessions to protect the possessions of the Supplier and of the erection personnel at the site,
 - e) protective clothing and protective devices needed due to particular conditions prevailing on the specific site.
2. Before the erection work starts, the Purchaser shall make available of its own accord any information required concerning the location of concealed electric power, gas and water lines or of similar installations as well as the necessary structural data.
3. Prior to assembly or erection, the materials and equipment necessary for the work to start must be available on the site of assembly/erection and any preparatory work must have advanced to such a degree that assembly/erection can be started as agreed and carried out without interruption. Access roads and the assembly/erection site itself must be level and clear.
4. If assembly, erection or commissioning is delayed due to circumstances for which the Supplier is not responsible, the Purchaser shall bear the reason-

* Translation of the original German text

able costs incurred for idle times and any additional travelling of the Supplier or the erection personnel.

- The Purchaser shall attest to the hours worked by the erection personnel towards the Supplier at weekly intervals and the Purchaser shall immediately confirm in writing if assembly, erection or commissioning has been completed.
- If, after completion, the Supplier demands acceptance of the Supplies, the Purchaser shall comply therewith within a period of two weeks. In default thereof, acceptance is deemed to have taken place. Acceptance is also deemed to have been effected if the Supplies are put to use, after completion of an agreed test phase, if any.

VII. RECEIVING OF SUPPLIES

The Purchaser shall not refuse to receive Supplies due to minor defects.

VIII. DEFECTS AS TO QUALITY

The Supplier shall be liable for defects as to quality („Sachmängel“, hereinafter referred to as „Defects“) as follows:

- All parts or services where a Defect becomes apparent within the limitation period shall, at the discretion of the Supplier, be repaired, replaced or provided again free of charge irrespective of the hours of operation elapsed, provided that the reason for the Defect had already existed at the time when the risk passed.
- Claims based on Defects are subject to a limitation period of 12 months. This provision shall not apply where longer periods are prescribed by law according to Sec. 438 para. 1 No. 2 (buildings and things used for a building), Sec. 479 para. 1 (right of recourse), and Sec. 634a para. 1 No. 2 (defects of a building) German Civil Code („BGB“), as well as in cases of injury of life, body or health, or where the Supplier intentionally or grossly negligently fails to fulfil its obligation or fraudulently conceals a Defect. The legal provisions regarding suspension of expiration („Ablaufhemmung“), suspension („Hemmung“) and recommencement of limitation periods remain unaffected.
- The Purchaser shall notify Defects to the Supplier in writing and without undue delay.
- In the case of notification of a Defect, the Purchaser may withhold payments to a reasonable extent taking into account the Defect occurred. The Purchaser, however, may withhold payments only if the subject-matter of the notification of the Defect occurred is justified beyond doubt. Unjustified notifications of Defect shall entitle the Supplier to have its expenses reimbursed by the Purchaser.
- The Supplier shall first be given the opportunity to supplement its performance („Nacherfüllung“) within a reasonable period of time.
- If supplementary performance is unsuccessful, the Purchaser shall be entitled to cancel the contract or reduce the remuneration, irrespective of any claims for damages it may have according to Art. XI.
- There shall be no claims based on Defect in cases of insignificant deviations from the agreed quality, of only minor impairment of usefulness, of natural wear and tear or damage arising after the transfer of risk from faulty or negligent handling, excessive strain, unsuitable equipment, defective workmanship, inappropriate foundation soil or from particular external influences not assumed under the contract, or from non-reproducible software errors. Claims based on defects attributable to improper modifications or repair work carried out by the Purchaser or third parties and the consequences thereof shall be likewise excluded.
- The Purchaser shall have no claim with respect to expenses incurred in the course of supplementary performance, including costs of travel and transport, labour, and material, to the extent that expenses are increased because the subject-matter of the Supplies was subsequently brought to another location than the Purchaser's branch office, unless doing so complies with the intended use of the Supplies.
- The Purchaser's right of recourse against the Supplier pursuant to Sec. 478 BGB is limited to cases where the Purchaser has not concluded an agreement with its customers exceeding the scope of the statutory provisions governing claims based on Defects. Moreover, No. 8 above shall apply mutatis mutandis to the scope of the right of recourse the Purchaser has against the Supplier pursuant to Sec. 478 para. 2 BGB.
- Furthermore, the provisions of Art. XI (Other Claims for Damages) shall apply in respect of claims of damages. Any other claims of the Purchaser against the Supplier or its agents or any such claims exceeding the claims provided for in this Art. VIII, based on a Defect, shall be excluded.

IX. INDUSTRIAL PROPERTY RIGHTS AND COPYRIGHT; DEFECTS IN TITLE

- Unless otherwise agreed, the Supplier shall provide the Supplies free from third parties' industrial property rights and copyrights (hereinafter referred to as „IPR“) with respect to the country of the place of destination. If a third party asserts a justified claim against the Purchaser based on an infringement of an IPR with respect to the Supplies made by the Supplier and then used in conformity with the contract, the Supplier shall be liable to the Purchaser within the time period stipulated in Art. VIII No. 2 as follows:
 - The Supplier shall choose whether to acquire, at its own expense, the right to use the IPR with respect to the Supplies concerned or whether to

modify the Supplies such that they no longer infringe the IPR or replace them. If this would be unreasonable to demand from the Supplier, the Purchaser may cancel the contract or reduce the remuneration pursuant to the appli-cable statutory provisions.

- The Supplier's liability to pay damages shall be governed by Art. XI.
 - The above obligations of the Supplier shall only apply if the Purchaser (i) immediately notifies the Supplier of any such claim asserted by the third party in writing, (ii) does not concede the existence of an infringement and (iii) leaves any protective measures and settlement negotiations to the discretion of the Supplier. If the Purchaser stops using the Supplies in order to reduce the damage or for other good reason, it shall be obliged to point out to the third party that no acknowledgement of the alleged infringement may be inferred from the fact that the use has been discontinued.
- Claims of the Purchaser shall be excluded if it is itself responsible for the infringement of an IPR.
 - Claims of the Purchaser shall also be excluded if the infringement of the IPR is caused by specifications made by the Purchaser, to a type of use not foreseeable by the Supplier or to the Supplies being modified by the Purchaser or being used together with products not provided by the Supplier.
 - In addition, with respect to claims by the Purchaser pursuant to No. 1 a) above, Art. VIII Nos. 4, 5, and 9 shall apply mutatis mutandis in the event of an infringement of an IPR.
 - Where other defects in title occur, Art. VIII shall apply mutatis mutandis.
 - Any other claims of the Purchaser against the Supplier or its agents or any such claims exceeding the claims provided for in this Art. IX, based on a defect in title, shall be excluded.

X. IMPOSSIBILITY OF PERFORMANCE; ADAPTATION OF CONTRACT

- To the extent that Supplies are impossible to be carried out, the Purchaser shall be entitled to claim damages, unless the Supplier is not responsible for the impossibility. The Purchaser's claim for damages shall, however, be limited to an amount of 10 % of the value of the part of the Supplies which, owing to the impossibility, cannot be put to the intended use. This limitation shall not apply in the case of mandatory liability based on intent, gross negligence or injury of life, body or health; this does not imply a change in the burden of proof to the detriment of the Purchaser. The right of the Purchaser to cancel the contract shall remain unaffected.
- Where unforeseeable events within the meaning of Art. IV No. 2 substantially change the economic importance or the contents of the Supplies or considerably affect the Supplier's business, the contract shall be adapted taking into account the principles of reasonableness and good faith. Where doing so is economically unreasonable, the Supplier shall have the right to cancel the contract. If the Supplier intends to exercise its right to cancel the contract, it shall notify the Purchaser thereof without undue delay after having realised the repercussions of the event; this shall also apply even where an extension of the delivery period had previously been agreed with the Purchaser.

XI. OTHER CLAIMS FOR DAMAGES

- Any claims for damages and reimbursement of expenses the Purchaser may have (hereinafter referred to as „Claims for Damages“), based on whatever legal reason, including infringement of duties arising in connection with the contract or tort, shall be excluded.
- The above shall not apply in the case of mandatory liability, e. g. under the German Product Liability Act („Produkthaftungsgesetz“), in the case of intent, gross negligence, injury of life, body or health, or breach of a condition which goes to the root of the contract („wesentliche Vertragspflichten“). However, Claims for Damages arising from a breach of a condition which goes to the root of the contract shall be limited to the foreseeable damage which is intrinsic to the contract, unless caused by intent or gross negligence or based on liability for injury of life, body or health. The above provision does not imply a change in the burden of proof to the detriment of the Purchaser.
- To the extent that the Purchaser has a valid Claim for Damages according to this Art. XI, it shall be time-barred upon expiration of the limitation period applicable to Defects pursuant to Art. VIII No. 2. In the case of claims for damages under the German Product Liability Act, the statutory provisions governing limitation periods shall apply.

XII. VENUE AND APPLICABLE LAW

- If the Purchaser is a businessperson, sole venue for all disputes arising directly or indirectly out of the contract shall be the Supplier's place of business. However, the Supplier may also bring an action at the Purchaser's place of business.
- Legal relations existing in connection with this contract shall be governed by German substantive law, to the exclusion of the United Nations Convention on Contracts for the International Sale of Goods (CISG).

XIII. SEVERABILITY CLAUSE

The legal invalidity of one or more provisions of this contract shall in no way affect the validity of the remaining provisions. This shall not apply if it would be unreasonable for one of the parties to continue the contract.

Notes

HENGSTLER INTERNATIONAL

■ GERMANY

Hengstler GmbH
Uhlandstr. 49
78554 Aldingen
Tel. +49-74 24-8 90
Fax +49-74 24-8 94 70/ 89 500
<http://www.hengstler.com>
info@hengstler.de

■ FRANCE

Hengstler Contrôle Numérique
S.A.R.L.
Z.I. des Mardelles
94-106, Rue Blaise Pascal, B.P. 71
93602 Aulnay-sous-Bois, Cédex
Tel. (01) 48795500
Fax (01) 48795561
<http://www.hengstler.fr>

■ GREAT BRITAIN

West Instruments
The Hyde
Brighton, East Sussex
BN2 4JU, England
Tel. +44 (0) 1273 606271
Fax +44 (0) 1273 609990
info@west-inst.co.uk
<http://www.westinstruments.com>

■ ITALY

ICG Holding S.r.l.
Via Leonardo da Vinci, 45/47
20020 Lainate (MI)
Tel. 0039-02 9330011
Fax 0039-02 93300129
info@icg-holding.com

■ SLOVAKIA

Hengstler sro
Pradiaren 40
060 01 Kezmarok
Tel :+421 52 46803 19,
Fax:+421 52 46803 99
milan.balla@hengstler.com

■ BRASIL

Veeder Root do Brasil
Com. e. Ind. Ltda.
Rua Ado Benatti, 92
Sao Paulo SP
CEP 05037-904
Tel 0055 11 361 121 55
Fax 0055 11 36 11 982
Antonio_Araujo@veeder.com

■ CHINA

Danaher ICG China
Shanghai Office
Room.904,Tower 1,
Kerry Everbright City
No.218,Tian Mu Road(W)
Shanghai 200070, China
Tel:+86 21 63539541, 33030472
Fax:+86 21 33030345
william.liu@danahericg.com.cn

■ CHINA

Danaher ICG - China
Beijing Office
Room 2202, Scitech Tower
22 Jianguomen Wai Street
Beijing 100004 PR China
Tel: 86-10-6512-0195
Fax: 86-10-6522-0887
frank.li@danahericg.com.cn

■ CHINA

Danaher ICG - China
Guangzhou Office
Room B2, 15th Floor,
Gao Sheng Building
No.109 Ti Yu Xi Road
Guangzhou 510620, China
Tel: +86 20-22646072
Fax: +86 20-22646069
tourist.luo@danahericg.com.cn

■ AGENTS

Argentina, Australia, Austria, Belgium, Brazil, Chile, China, Czech Republic, Denmark, Finland, France, Germany, Guatemala, Great Britain, Greece, Hong Kong, Hungary, India, Indonesia, Israel, Italia, Japan, Korea, Lebanon, Luxemburg, Malaysia, Mexico, Netherlands, New Zealand, Norway, Peru, Philippines, Poland, Portugal, Singapore, Slovenia, South Africa, Spain, Sweden, Switzerland, Taiwan, Thailand, Turkey, United Arab Emirates, USA, Venezuela, Vietnam

■ JAPAN

Danaher ICG Japan Co. Ltd.
2-12-23, Minamikaneden
Suita-shi
Osaka 564-0044
Tel. (06) 63868001
Fax (06) 63865022
csc@danaher.co.jp
<http://www.hengstler.co.jp/>

■ SINGAPORE

Danaher Industrial Control
Group - Singapore
246 MacPherson Road
#08-01 Betime Building
Singapore 348578
Tel. 65-6-7459265,
Fax 65-6-7461791
Pager: 94158924
fredtay@singnet.com.sg

■ USA

Danaher Controls
1675 Delaney Road
Gurnee, IL 60031-1282
Tel. (847) 662.2666
Fax (847) 662.6633
dancon@dancon.com
<http://www.dancon.com>

■ USA

HECON
2100 West Broad Street
P.O. Box 368
Elizabethtown, NC 28337
Tel. 910.879.5493
Fax 910.862.5408
info.hecon@hecon.com
<http://www.hecon.com>
- nur für Drucker + Abscheider
- only for Printers + Cutters

HENGSTLER

Hengstler GmbH
Uhlandstr. 49
78554 Aldingen
Tel. +49-74 24-8 90
Fax +49-74 24-8 94 70/ 89 500
<http://www.hengstler.com>
info@hengstler.de



DQS certified according DIN EN ISO 9001
Reg. No. 1540-01



www.hengstler.de
0800-HENGSTLER
436478537

DOC 1209.18 E

Encoders programme · 01/2006 / 1500 · HohlDruck
printed in Germany on environmentally friendly paper
from chlorine- and acid-free production