

41206ESDA

ESD suppressor four-channel



Product features

- The best ESD protection for high frequency, low voltage applications.
- Protects up to 4 separate lines with one device
- Exceeds testing requirements outlined in IEC 61000-4-2
- Extremely low capacitance
- Very low leakage current
- Fast response time
- Bi-directional
- Surface mount
- Solder termination
- RoHS compliant

Device marking

ESDA devices are marked on the tape and reel packages, not individually. Since the product is bi-directional and symmetrical, no orientation marking is required.

Device application

ESDA family are applicable to most signal line circuits. It is applied in a shunt-connected manner. They are not suitable for use on lines where lightning or load-switching transients are present. ESDA family is ideal for use in computers and computer-related equipment, such as modems, keyboards, and printers. ESDA family is also well suited for portable electronic equipment such as mobile telephones, test equipment, and card scanners.

Processing recommendations

ESDA family currently have a convex profile on the top surface of the part. This profile is a result of the construction of the device. They can be processed using standard pick – and – place equipment. The placement and processing techniques for ESDA family are similar to those used for chip resistors and chip capacitors.

The Location in the circuit for the ESDA family has to be carefully determined. For the better performance of the device, the device should be positioned as close to the signal input as possible and ahead of any other component.

Part Numbering

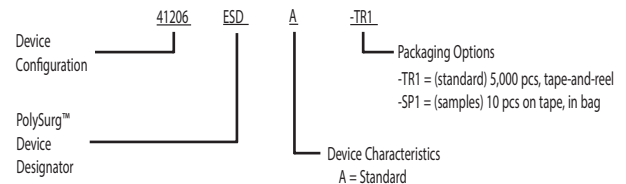

Note: Spacing in part number is shown for clarity only. Device part number contains no spaces (e.g.41206ESDA-TR1)

Part Ratings and Characteristics:

Performance Characteristics	Units	Min	Typ	Max
Continuous operating voltage	VDC	-	12 ¹	-
Clamping voltage ³	V	-	35	60
Trigger voltage ⁴	V	-	150	300
ESD Threat voltage capability ⁵	kV	-	8	15
Capacitance (@ 1 KHz ~ 1.8GHz)	pF	-	0.15	1
Leakage current (@ 12 VDC)	nA	-	-	100
Peak current ³	A	-	30	45
Operating temperature	°C	-40	+25	+105
ESD pulse withstand ³	# pulses	20	>500 ²	-

Notes:

1. The product is 100% tested for 30V operating voltage at 25°C. Continuous operation with higher than 12VDC under extreme temperature and humidity may cause increasing leakage current and/or shifting device resistance. However, even under severe environmental test, characteristics of the device did not change up to 12VDC operation.
2. Some shifting in characteristics may occur when tested over several hundred ESD pulses at very rapid rate of 1 pulse per second or faster.
3. Per IEC 61000-4-2, 30A @ 8kV, level 4, clamp measurement made 30 ns after initiation of pulse, all tests in contact discharge mode.
4. Trigger measurement made using Transmission Line Pulse (TLP) method.
5. PolySurg™ devices are capable of withstanding up to a 15 kV, 45A ESD pulse. Device ratings are given at 8kV per Note 1, unless otherwise specified.



Powering Business Worldwide

Environmental Specifications:

- Moisture Resistance: MIL-STD-883, Method 1004.7, 85°C, 85%R.H., 240 hrs.
- Thermal shock: MIL-STD-202, Method 107G, -65°C to 125°C, 30 min. cycle, 5 cycles
- Vibration: MIL-STD-202F, Method 201A, (10 to 55 to 10 Hz, 1 min. cycle, 2 hrs each in X-Y-Z)
- Chemical resistance: ASTM D-543, 24 hrs @ 50°C, 3 solutions (H2O, detergent solution, defluxer)
- Full load voltage: Up to 24 VDC, 1000 hrs, 25°C
- Solder leach resistance and terminal adhesion: Per EIA-576
- Solderability: MIL-STD-202, Method 208 (95% coverage)

Product Dimension

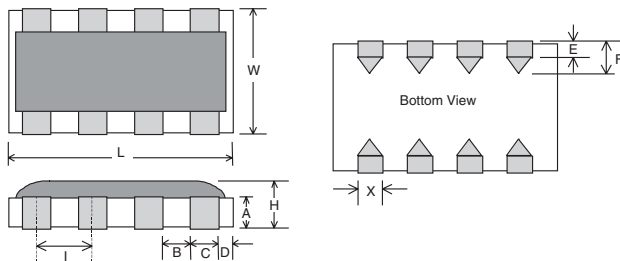

EIA Size	L	W	H	A	B
41206	3.2 ± 0.2	1.6 ± 0.2	0.8 max	0.38 ± 0.5	0.2 min, 0.4 typ
mm(inch)	$(.126 \pm .008)$	$(.063 \pm .008)$	(.032 max)	$(.015 \pm .002)$	(.008 min, .16 Typ)
C	D	E	F	I	X
0.4 Typ (.016 Typ)	0.2 ± 0.1 (.008 ± .004)	0.2 Typ (.008 Typ)	0.38 ± 0.10 (.015 ± .004)	0.80 ± 0.02 (.03 ± .0008)	0.45 ± 0.02 (.017 ± .0008)

Recommended Solder Pad Outline
(per IPC-SM-782)

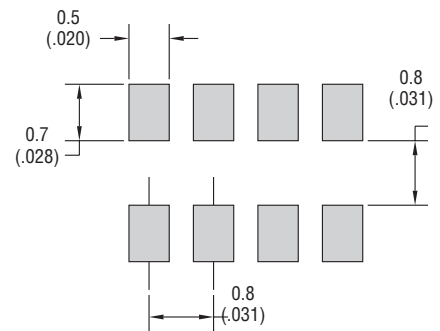

Tape-and-Reel Specification

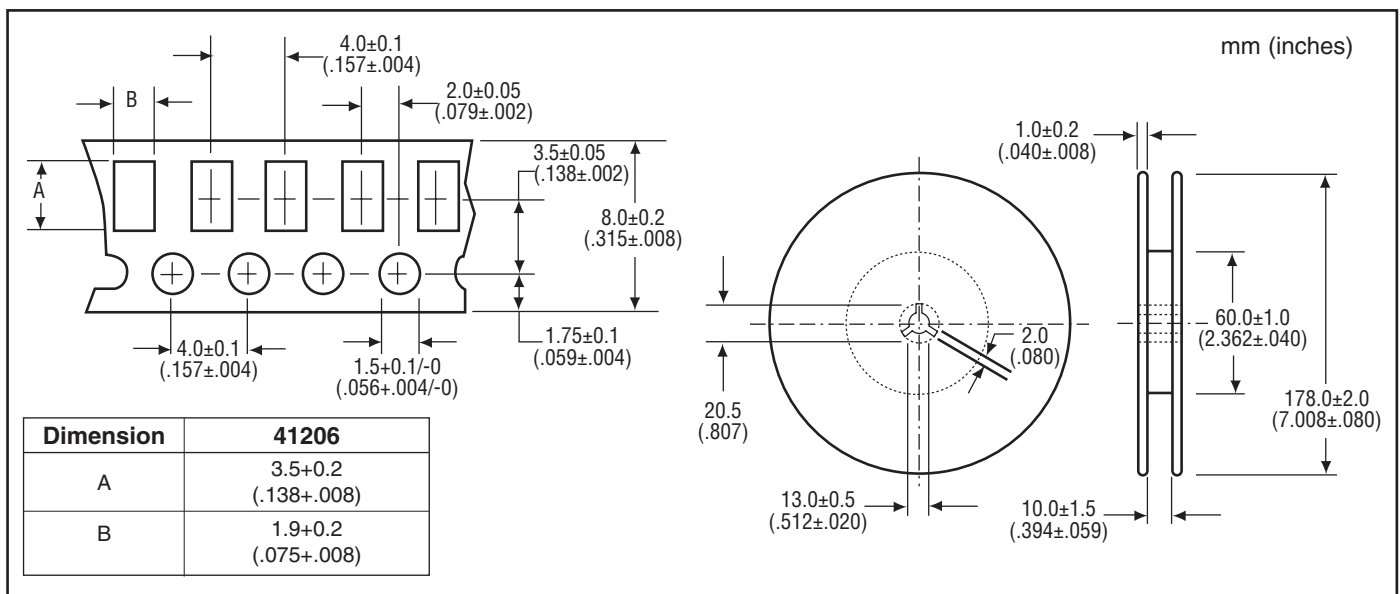

Typical Applications

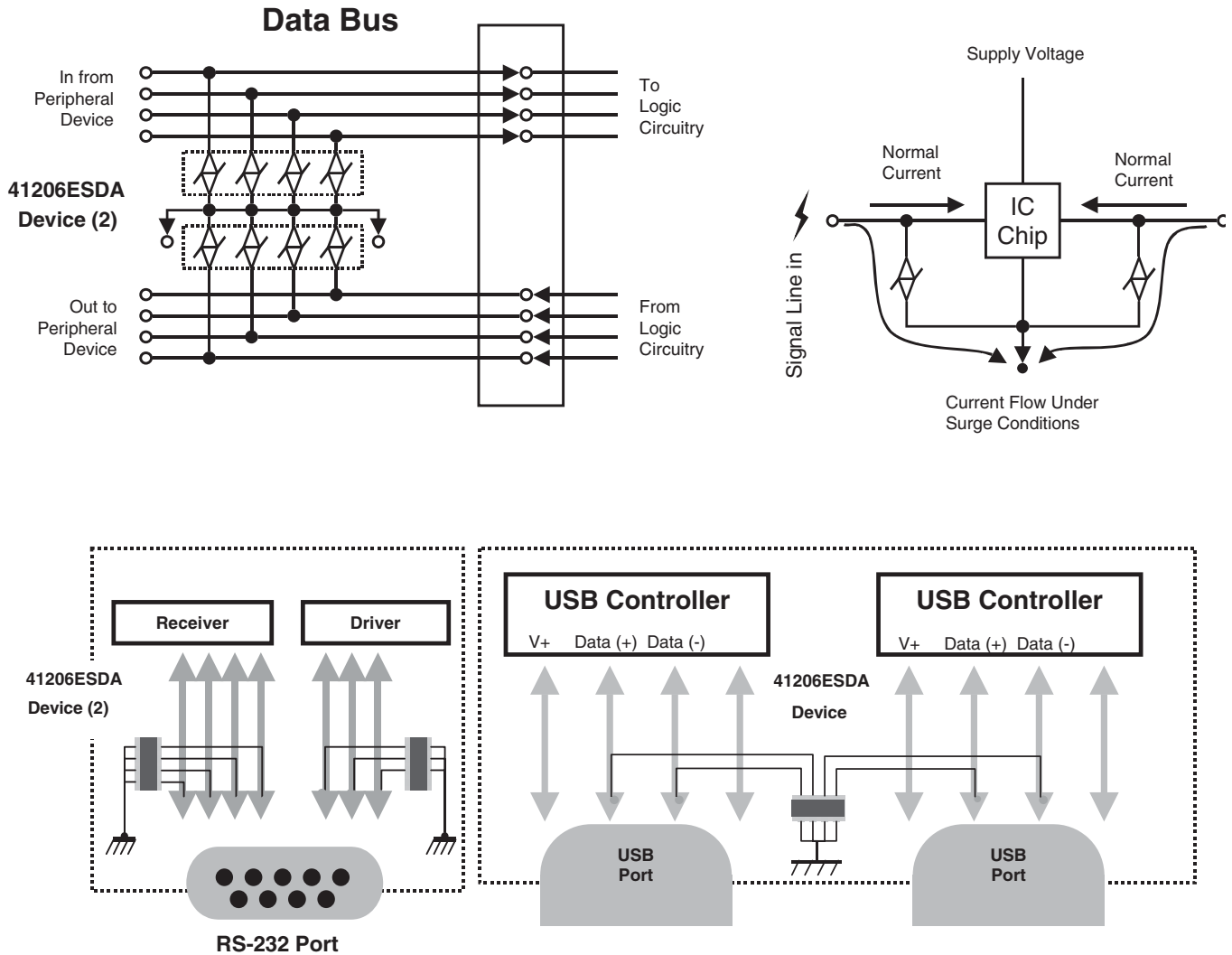

Life Support Policy: Eaton does not authorize the use of any of its products for use in life support devices or systems without the express written approval of an officer of the Company. Life support systems are devices which support or sustain life, and whose failure to perform, when properly used in accordance with instructions for use provided in the labeling, can be reasonably expected to result in significant injury to the user.

Eaton reserves the right, without notice, to change design or construction of any products and to discontinue or limit distribution of any products. Eaton also reserves the right to change or update, without notice, any technical information contained in this bulletin.

Eaton
Electronics Division
1000 Eaton Boulevard
Cleveland, OH 44122
United States
www.eaton.com/electronics

© 2017 Eaton
All Rights Reserved
Printed in USA
Publication No. DS41206
May 2017



Eaton is a registered trademark.

All other trademarks are property of their respective owners.