

MCF (Monolithic Crystal Filters)

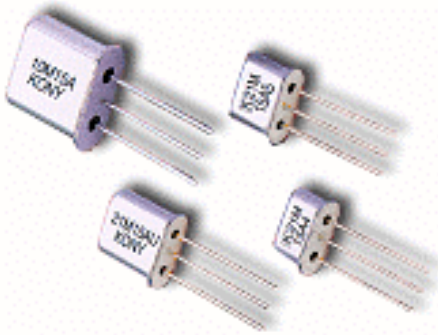

■ Feature

- Compact and Light Weight

■ Specification

1. 10.7MHz Series

| Model | Center Frequency (MHz) | Pole | Pass Bandwidth | | Stop Bandwidth | | Ripple (dB max.) | Insertion Loss (dB max.) | Terminating Impedance (Ω //pF) | Case | Test Circuit |
|--------|------------------------|------|----------------|----|----------------|----|------------------|--------------------------|--|------|--------------|
| | | | KHz(min.) | dB | KHz(max.) | dB | | | | | |
| 10M08A | 10.700 | 2 | ± 3.75 | 3 | ± 12.5 | 18 | 0.5 | 2.0 | 1.5K//5.0 | 49/T | Fig.3 |
| 10M08B | 10.700 | 4 | ± 3.75 | 3 | ± 12.5 | 40 | 1.0 | 2.0 | 1.5K//3.0 (Cc=15pF) | 49/T | Fig.4 |
| 10L08A | 10.695 | 2 | ± 3.75 | 3 | ± 12.5 | 18 | 0.5 | 2.0 | 1.5K//5.0 | 49/T | Fig.3 |
| 10L08B | 10.695 | 4 | ± 3.75 | 3 | ± 12.5 | 40 | 1.0 | 2.0 | 1.5K//3.0 (Cc=15pF) | 49/t | Fig.4 |
| 10M15A | 10.700 | 2 | ± 7.50 | 3 | ± 25.0 | 18 | 0.5 | 2.0 | 3.0K//1.0 | 49/T | Fig.3 |
| 10M15B | 10.700 | 4 | ± 7.50 | 3 | ± 25.0 | 40 | 1.0 | 2.0 | 3.0K//1.0 (Cc=5pF) | 49/T | Fig.4 |
| 10L15A | 10.695 | 2 | ± 7.50 | 3 | ± 25.0 | 18 | 0.5 | 2.0 | 3.0K//1.0 | 49/T | Fig.3 |
| 10L15B | 10.695 | 4 | ± 7.50 | 3 | ± 25.0 | 40 | 1.0 | 2.0 | 3.0K//1.0 (Cc=5pF) | 49/T | Fig.4 |

2. 21.4MHz Series(21.7MHz Available)

| Model | Center Frequency (MHz) | Pole | Pass Bandwidth | | Stop Bandwidth | | Ripple (dB max.) | Insertion Loss (dB max.) | Terminating Impedance (Ω //pF) | Case | Test Circuit |
|----------|------------------------|------|----------------|----|----------------|----|------------------|--------------------------|--|------|--------------|
| | | | KHz(min.) | dB | KHz(max.) | dB | | | | | |
| 21M08AU | 21.400 | 2 | ± 3.75 | 3 | ± 15.0 | 18 | 0.5 | 2.0 | 850//6.0 | UM-1 | Fig.3 |
| 21M08AU5 | 21.400 | 2 | ± 3.75 | 3 | ± 15.0 | 18 | 0.5 | 2.0 | 850//6.0 | UM-5 | Fig.3 |
| 21M08BU | 21.400 | 4 | ± 3.75 | 3 | ± 12.5 | 35 | 1.0 | 2.0 | 900//2.0 (Cc=14pF) | UM-1 | Fig.4 |
| 21M12AU | 21.400 | 2 | ± 6.00 | 3 | ± 22.0 | 18 | 0.5 | 2.0 | 910//3.0 | UM-1 | Fig.3 |
| 21M12BU | 21.400 | 4 | ± 6.00 | 3 | ± 20.0 | 40 | 1.0 | 2.0 | 1.5K//2.0 (Cc=9pF) | UM-1 | Fig.4 |
| 21M15AU | 21.400 | 2 | ± 7.50 | 3 | ± 25.0 | 18 | 0.5 | 2.0 | 1.5K//2.5 | UM-1 | Fig.3 |
| 21M15BU | 21.400 | 4 | ± 7.50 | 3 | ± 25.0 | 40 | 1.0 | 2.0 | 1.5K//1.0 (Cc=6pF) | UM-1 | Fig.4 |
| 21M15AU5 | 21.400 | 2 | ± 7.50 | 3 | ± 25.0 | 18 | 0.5 | 2.0 | 1.5K//2.5 | UM-5 | Fig.3 |



MCF (Monolithic Crystal Filters)

■ Package Details

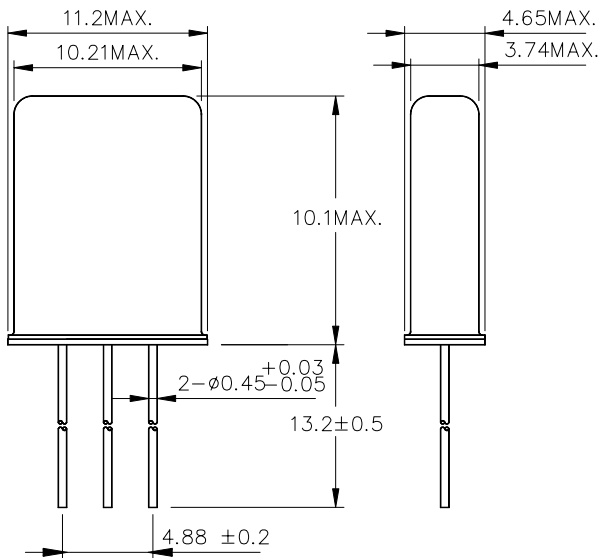

Figure 1 49/T Package

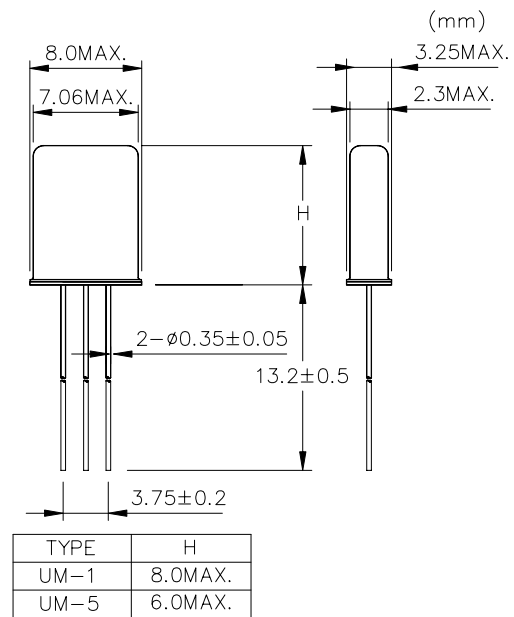

Figure 2 UM Series Package

■ Test Circuits

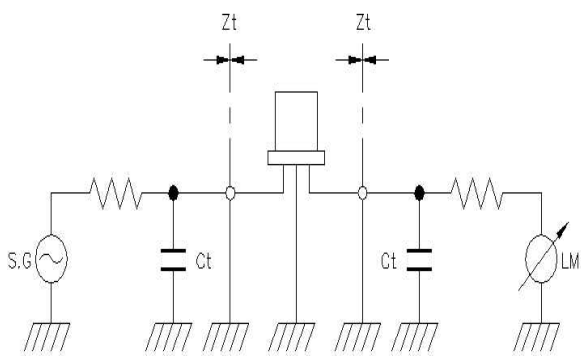

Figure 3

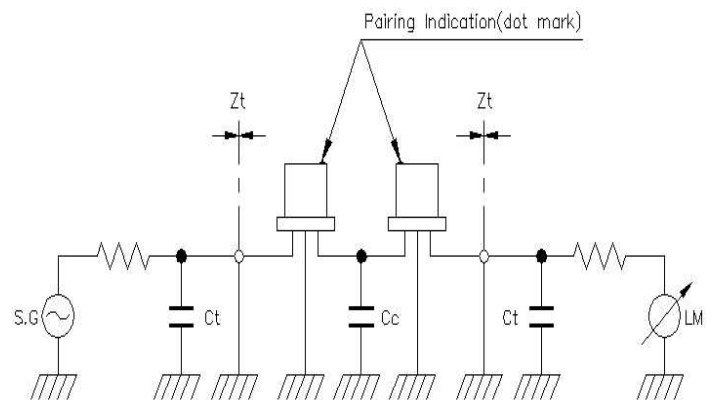
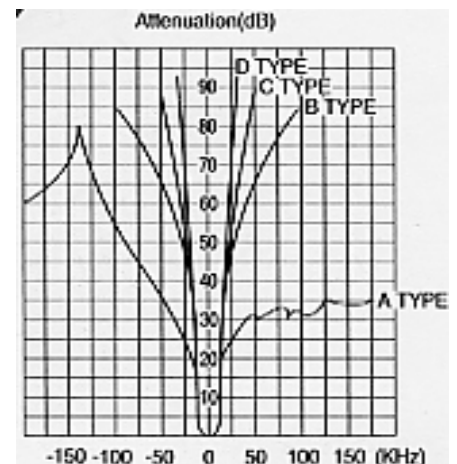
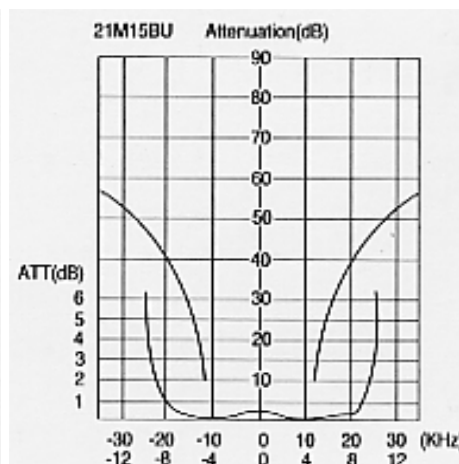
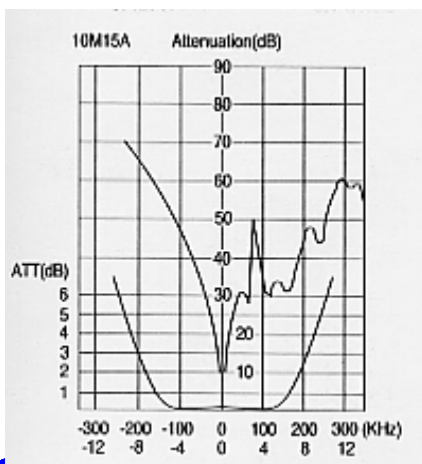

Figure 4

■ Wave Forms



MCF (Monolithic Crystal Filters)

■ Terms and Definitions

Center Frequency : A frequency given in the specification.

Pass Band Width : Frequency bands(KHz) where attenuation is equal to or below specified figure(dB)
In pass band.

Stop Band Width : Frequency bands(KHz) where attenuation are equal to or bigger specified figure(dB)
In pass band.

Insertion Loss : Loss(dB) defined logarithmic ratio of power transmitted to load before and after
Insertion of filter.

Ripple : Difference(dB) between maximum and minimum attenuation in pass band.

Attenuation Guaranteed :

Attenuation Guaranteed(dB) at specified frequency range.

Spurious : Attenuation(dB) caused by wild response in stop band.

Group Delay Distortion :

Difference(μ sec) between maximum and minimum group delay in pass band.

Terminating Impedance :

Impedance terminating to source side and load side of filter, described by resistance(Ω)
and parallel capacitance(pF).

