

## Applications

- Repeaters
- Mobile Infrastructure
- LTE / WCDMA / EDGE / CDMA
- General Purpose Wireless

## Product Features

- 50 – 4000 MHz
- 20.6 dB Gain at 1.9 GHz
- +36 dBm Output IP3
- 1.3 dB Noise Figure at 1.9 GHz
- 50 Ohm Cascadable Gain Block
- Unconditionally stable
- High input power capability
- +5 V Single Supply, 85 mA Current
- SOT-89 Package

## General Description

The TQP3M9008 is a cascadable, high linearity gain block amplifier in a low-cost surface-mount package. At 1.9 GHz, the amplifier typically provides 20.6 dB gain, +36 dBm OIP3, and 1.3 dB Noise Figure while only drawing 85 mA current. The device is housed in a lead-free/green/RoHS-compliant industry-standard SOT-89 package using a NiPdAu plating to eliminate the possibility of tin whiskering.

The TQP3M9008 has the benefit of having high gain across a broad range of frequencies while also providing very low noise. This allows the device to be used in both receiver and transmitter chains for high performance systems. The amplifier is internally matched using a high performance E-pHEMT process and only requires an external RF choke and blocking/bypass capacitors for operation from a single +5 V supply. The internal active bias circuit also enables stable operation over bias and temperature variations.

The TQP3M9008 covers the 0.05 – 4 GHz frequency band and is targeted for wireless infrastructure or other applications requiring high linearity and/or low noise figure.



3-pin SOT-89 Package

## Functional Block Diagram

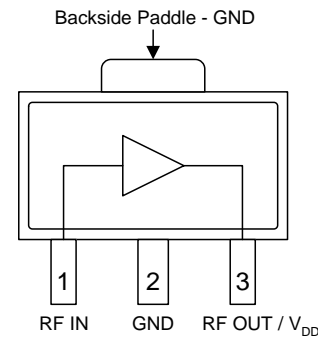

## Pin Configuration

Pin No.	Label
1	RF Input
2	GND
3	RF Output / V <sub>DD</sub>
Backside Paddle	GND

## Ordering Information

Part No.	Description
TQP3M9008	High Linearity LNA Gain Block
TQP3M9008-PCB_IF	0.05 – 0.5 GHz Evaluation Board
TQP3M9008-PCB_RF	0.5 – 4.0 GHz Evaluation Board

Standard T/R size = 1000 pieces on a 7" reel

### Absolute Maximum Ratings

Parameter	Rating
Storage Temperature	-65 to 150 °C
RF Input Power, CW, 50Ω, T=25°C	+23 dBm
Device Voltage (V <sub>DD</sub> )	+7 V
Reverse Device Voltage	-0.3 V

Operation of this device outside the parameter ranges given above may cause permanent damage.

### Recommended Operating Conditions

Parameter	Min	Typ	Max	Units
Device Voltage (V <sub>DD</sub> )	+3.0	+5.0	+5.25	V
T <sub>CASE</sub>	-40		+105	°C
T <sub>j</sub> for >10 <sup>6</sup> hours MTTF			+190	°C

Electrical specifications are measured at specified test conditions. Specifications are not guaranteed over all recommended operating conditions.

### Electrical Specifications

Test conditions unless otherwise noted: V<sub>DD</sub> = +5 V, Temp. = +25 °C, 50 Ω system

Parameter	Conditions	Min	Typ	Max	Units
Operational Frequency Range		50		4000	MHz
Test Frequency			1900		MHz
Gain		19	20.6	22	dB
Input Return Loss			16		dB
Output Return Loss			17		dB
Output P1dB			+20		dBm
Output IP3	P <sub>out</sub> = +3 dBm/tone, Δf = 1 MHz	+32.5	+36		dBm
Noise Figure			1.3		dB
Current, I <sub>DD</sub>			85	100	mA
Thermal Resistance, θ <sub>jc</sub>	Junction to case			38.7	°C/W

**S-Parameters**

Test Conditions:  $V_{DD} = +5V$ ,  $I_{DD} = 85mA$ , Temp. =  $+25^{\circ}C$ ,  $50\Omega$  system, calibrated to device leads

Freq (MHz)	S11 (dB)	S11 (ang)	S21 (dB)	S21 (ang)	S12 (dB)	S12 (ang)	S22 (dB)	S22 (ang)
50	-12.5	-170.0	23.6	172.9	-26.7	0.6	-9.8	177.2
100	-11.9	-175.1	23.5	167.7	-26.7	-1.9	-9.9	171.9
200	-11.4	178.0	23.1	159.5	-26.6	-5.5	-10.0	162.2
400	-11.4	167.0	22.7	144.1	-26.7	-12.9	-10.5	145.5
600	-11.6	154.1	22.3	129.4	-26.7	-19.6	-10.7	129.3
800	-11.8	147.2	22.0	114.6	-26.7	-26.1	-11.3	111.8
1000	-12.3	139.1	21.7	99.5	-26.8	-33.4	-12.4	94.3
1200	-12.7	132.1	21.4	85.6	-26.9	-39.9	-13.1	77.8
1400	-13.3	126.3	21.0	71.0	-27.1	-47.7	-14.3	58.7
1600	-13.6	116.9	20.8	56.2	-27.4	-56.5	-15.4	36.8
1800	-13.9	110.2	20.5	41.8	-27.6	-63.3	-16.3	15.3
2000	-14.3	103.5	20.3	27.9	-28.1	-71.6	-17.5	-11.2
2200	-15.1	94.6	19.9	13.8	-28.5	-80.2	-18.0	-39.1
2400	-15.8	85.2	19.7	-1.1	-28.7	-88.9	-17.4	-65.9
2600	-16.8	72.7	19.5	-16.0	-29.4	-96.8	-16.6	-94.2
2800	-18.0	55.2	19.2	-31.3	-29.9	-105.7	-14.9	-115.0
3000	-19.8	25.5	19.0	-46.9	-30.6	-117.1	-14.1	-131.7
3200	-19.9	-16.8	18.6	-63.5	-31.0	-128.0	-13.1	-148.3
3400	-17.8	-59.0	18.3	-80.5	-31.8	-139.4	-12.4	-160.2
3600	-14.3	-90.8	17.7	-98.5	-32.8	-154.4	-11.9	-173.9
3800	-11.3	-114.3	17.0	-117.1	-34.0	-168.1	-11.2	174.5
4000	-8.7	-132.7	16.1	-135.8	-34.8	173.1	-10.7	167.6

**TQP3M9008-PCB\_IF/RF Evaluation Board**

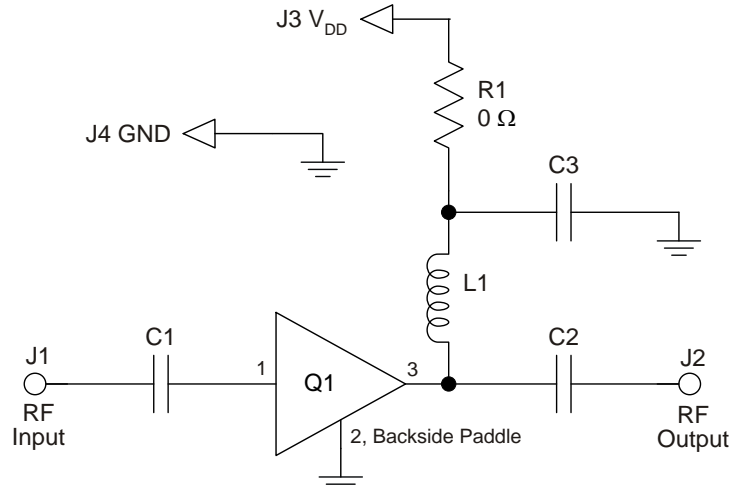
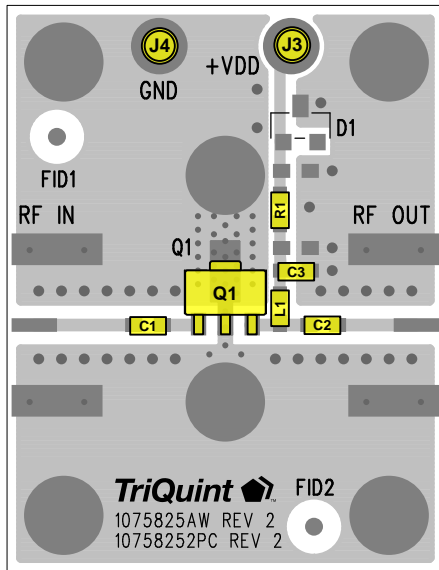

Notes:

1. See Evaluation Board PCB section for material and stack-up.
2. Components shown on the silkscreen but not on the schematic are not used.
3. R1 (0 Ω jumper) may be replaced with copper trace in the target application layout.
4. The recommended component values are dependent upon the frequency of operation.
5. All components are of 0603 size unless stated on the schematic.

**Bill of Material – TQP3M9008-PCB\_IF/RF**

Reference Designation	TQP3M9008-PCB_IF	TQP3M9008-PCB_RF
	50 - 500 MHz	500 - 4000 MHz
Q1	TQP3M9008	TQP3M9008
C1, C2	1000 pF	100 pF
C3	0.01 uF	0.01 uF
L1	330 nH	68 nH
D1	Do Not Place	
R1	0 Ω	

Performance can be optimized at frequency of interest by using recommended component values shown in the table below.

Reference Designation	Frequency (MHz)			
	500	2000	2500	3500
C1, C2	100 pF	22 pF	22 pF	22 pF
L1	82 nH	22 nH	18 nH	15 nH

**Typical Performance – TQP3M9008-PCB\_RF**

Test conditions unless otherwise noted:  $V_{DD}=+5V$ ,  $I_{DD}=85mA$ ,  $Temp=+25^{\circ}C$ ,  $50\ \Omega$  system

Parameter	Typical Value							Units
Frequency	500	900	1900	2700	3500	4000		MHz
Gain	22.8	22.3	20.6	19.0	17.6	16.0		dB
Input Return Loss	10	12	16	18	10	7.3		dB
Output Return Loss	9.5	12	17	13	12.4	14		dB
Output P1dB	+20.9	+19.7	+19.9	+19.4	+19.7	+18.5		dBm
OIP3	+37.5	+37.6	+36	+35.3	+34.7	+33.7		dBm
Noise figure	1.1	1.1	1.3	1.6	2	2.5		dB

Notes:

- OIP3 measured with two tones at an output power of +3 dBm / tone separated by 1 MHz.
- Noise figure values in the table above includes board losses. Approx. =0.1dB at 2 GHz.

**Performance Plots – TQP3M9008-PCB\_RF**

Test conditions unless otherwise noted:  $V_{DD} = +5V$ ,  $I_{DD} = 85mA$ ,  $Temp. = +25^{\circ}C$ ,  $50\ \Omega$  system

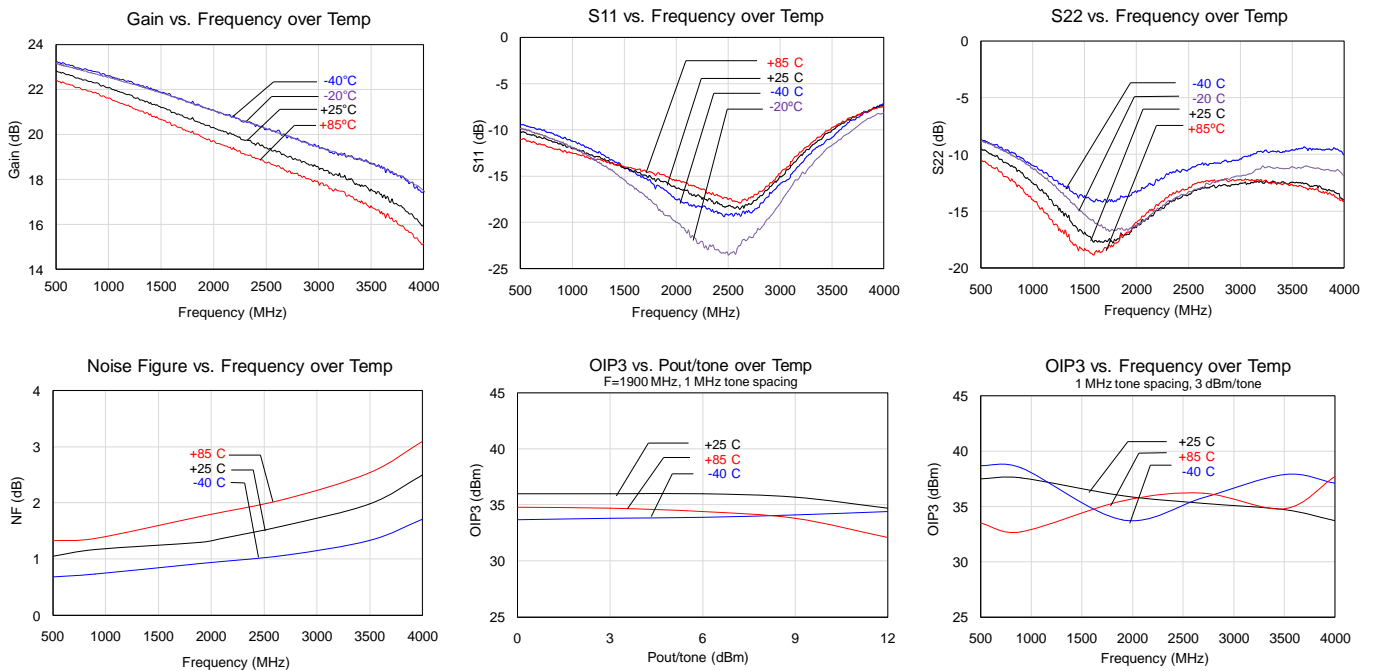

**Performance Plots – TQP3M9008-PCB\_RF**

Test conditions unless otherwise noted:  $V_{DD} = +5V$ ,  $I_{DD} = 85mA$ , Temp. =  $+25^{\circ}C$ ,  $50\Omega$  system

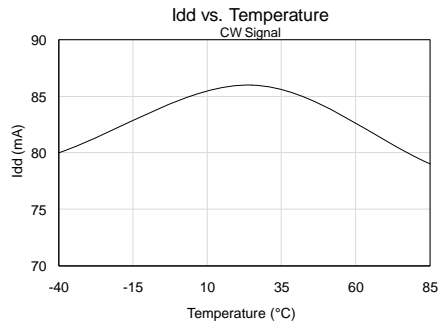
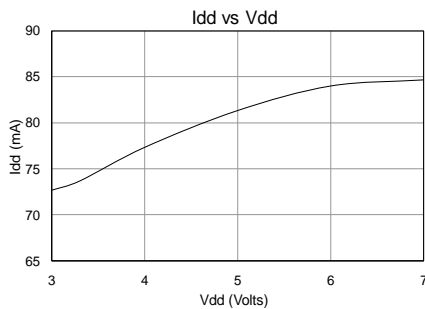
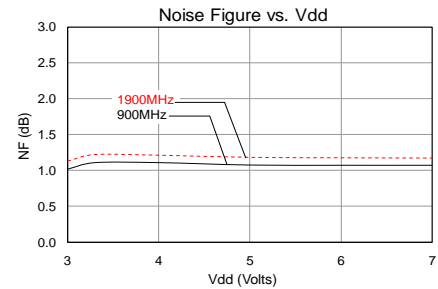
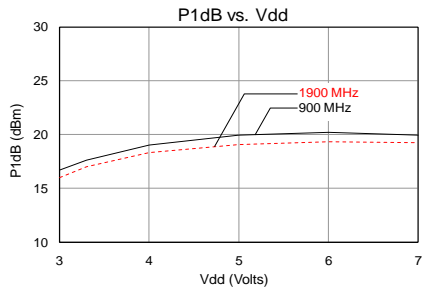
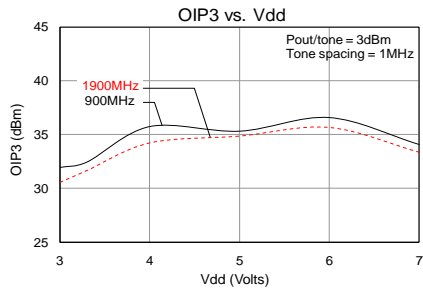
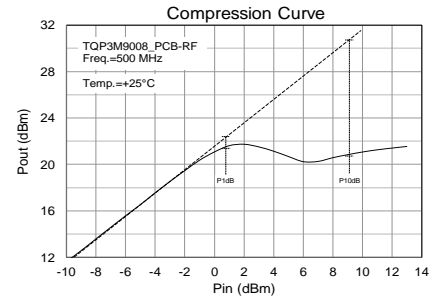
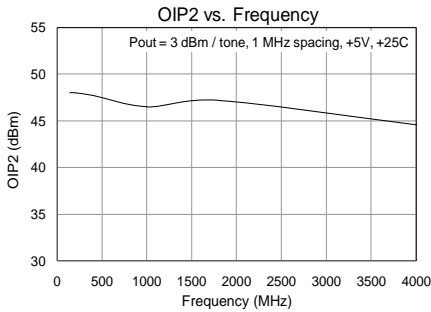
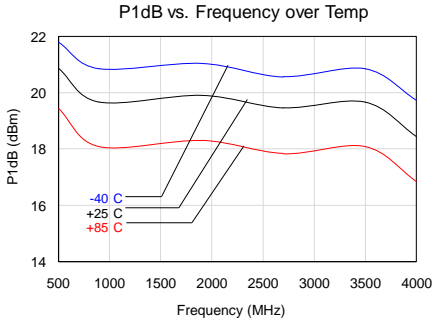

**Typical Performance – TQP3M9008-PCB\_IF**

Test conditions unless otherwise noted:  $V_{DD} = +5V$ ,  $I_{DD} = 85mA$ , Temp. =  $+25^{\circ}C$ ,  $50\Omega$  system

Parameter	Typical Value				Units
Frequency	70	100	200	500	MHz
Gain	23.2	23.2	22.9	22.3	dB
Input Return Loss	10	11	11	11	dB
Output Return Loss	9	9	10	10	dB
Output P1dB	+19.8	+20.2	+19.9	+19.9	dBm
OIP3	+37	+37	+37	+37	dBm
Noise figure	1.2	1.1	0.8	1.1	dB

Notes:

- OIP3 measured with two tones at an output power of +3 dBm / tone separated by 1 MHz.
- Noise figure values in the table above includes board losses. Approx. =0.1dB at 2 GHz.

**Performance Plots – TQP3M9008-PCB\_IF**

Test conditions unless otherwise noted:  $V_{DD} = +5V$ ,  $I_{DD} = 85mA$ , Temp =  $+25^{\circ}C$ ,  $50\Omega$  system.

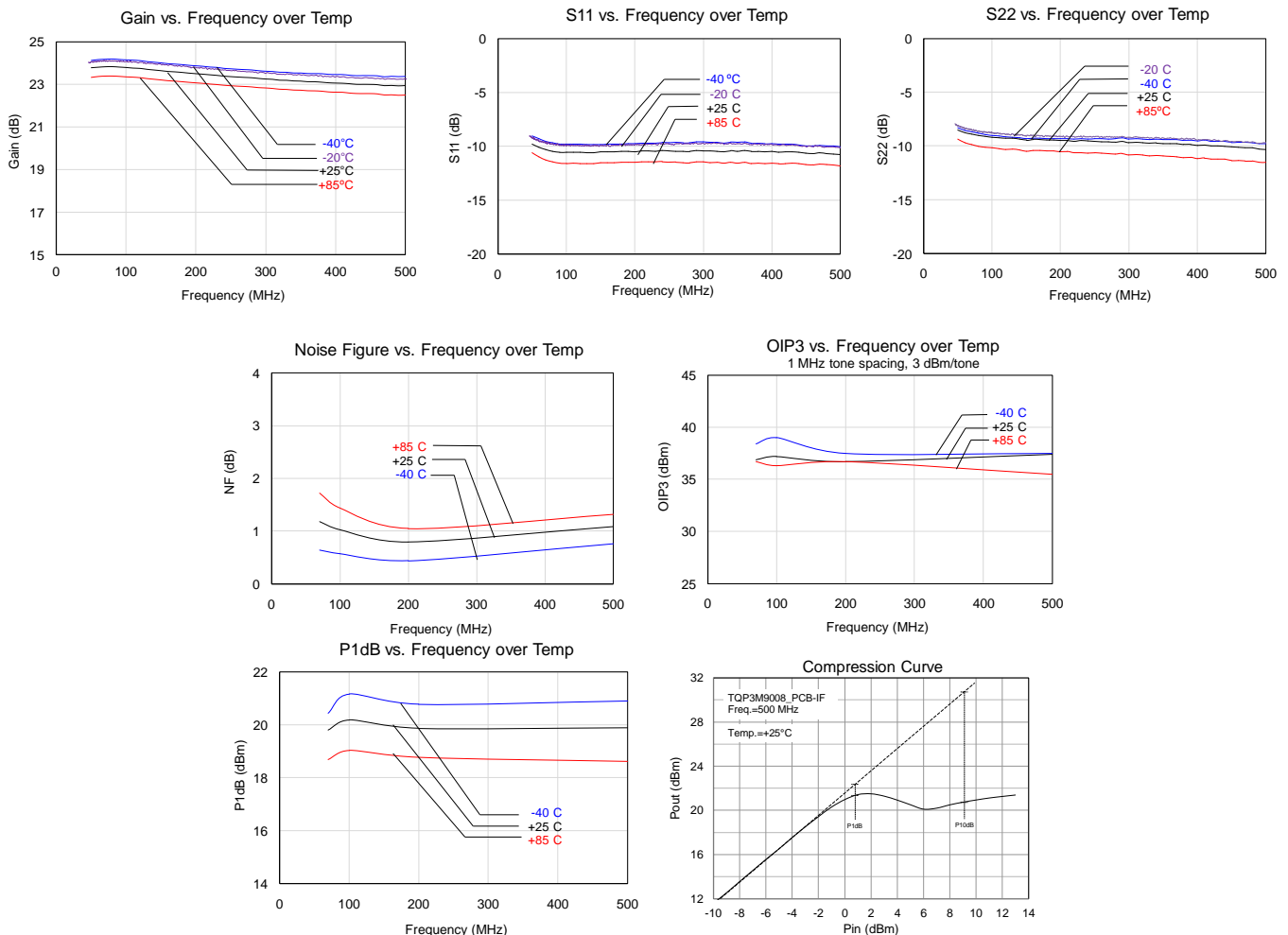

**Pin Configuration and Description**

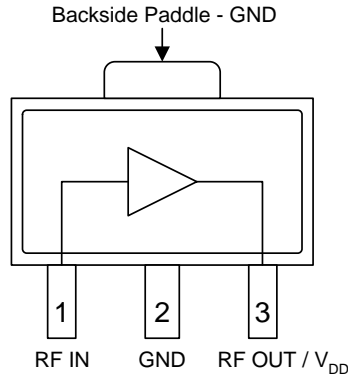

Pin No.	Label	Description
1	RF IN	RF input; matched to 50 ohms. External DC Block is required.
2, Backside Paddle	GND	RF/DC ground. Use recommended via pattern to minimize inductance and thermal resistance. See PCB Mounting Pattern for suggested footprint.
3	RF OUT / V <sub>DD</sub>	RF output, matched to 50 ohms. External DC Block and bias voltage required.

**Evaluation Board PCB**

Qorvo PCB 1075825 Material and Stack-up

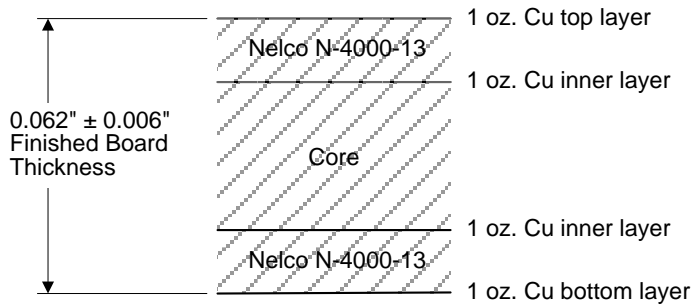

50 ohm line dimensions: width = .028", spacing = .028"

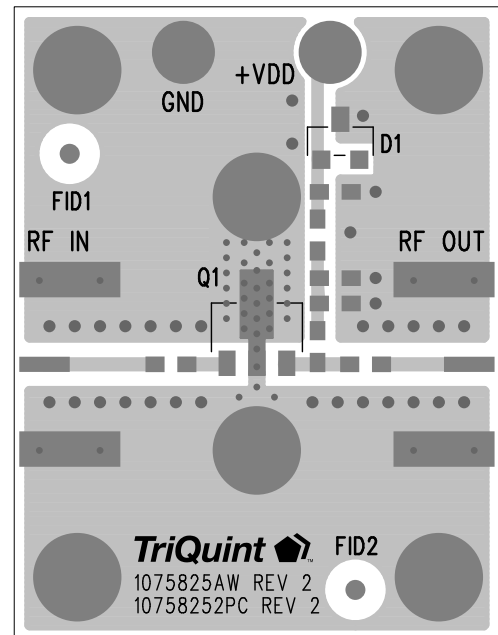



**Package Marking and Dimensions**

**Package Marking**  
Product Identifier: 3M9008  
Assembly Code: YXXX

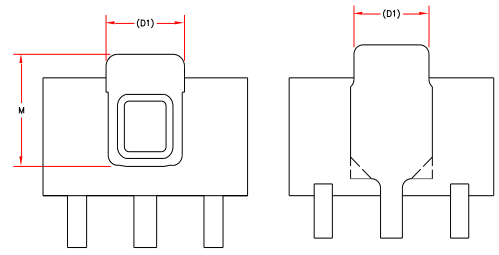
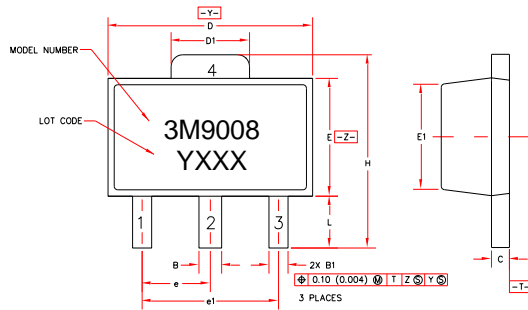

Alternate Backside Patterns  
(May be supplied with either pattern shown)

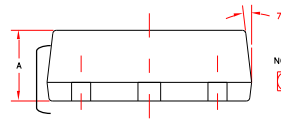

- NOTES:  
 1. DIMENSIONS CONFORM WITH JEDEC TO-243C EXCEPT WHERE INDICATED.  
 2. DIMENSIONS ARE EXPRESSED IN MM (INCHES).  
 3. DIMENSIONING AND TOLERANCING IAW ANSI Y14.5M

SYMBOL	MIN	NOM	MAX
A	1.40 (.055)	1.50 (.059)	1.60 (.063)
B	.44 (.017)	.50 (.020)	.56 (.022)
B1	.36 (.014)	.42 (.0165)	.48 (.019)
C	.35 (.014)	.40 (.016)	.44 (.017)
D	4.40 (.173)	4.50 (.177)	4.60 (.181)
D1	1.62 (.064)	1.73 (.068)	1.83 (.072)

SYMBOL	MIN	NOM	MAX
E	2.29 (.090)	2.50 (.098)	2.60 (.102)
E1	2.13 (.084)	2.20 (.087)	2.29 (.090)
e	1.50 BSC (.059)		
e1	3.00 BSC (.118)		
H	3.94 (.155)	4.10 (.161)	4.25 (.167)
L	.89 (.035)	1.10 (.043)	1.20 (.047)
M	2.2 (.087)	2.40 (.095)	2.6 (.102)

**Notes:**

- All dimensions are in millimeters. Angles are in degrees.
- Dimension and tolerance formats conform to ASME Y14.4M-1994.
- The terminal #1 identifier and terminal numbering conform to JESD 95-1 SPP-012.
- Contact plating: NiPdAu

**PCB Mounting Pattern**

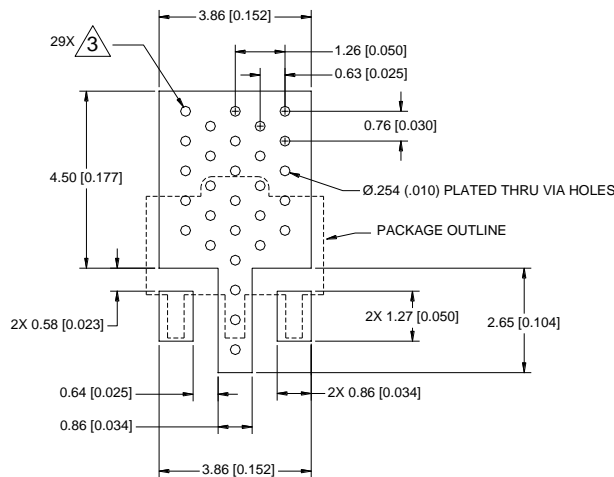

**NOTES:**

- All dimensions are in millimeters[inches]. Angles are in degrees.
- Use 1 oz. copper minimum for top and bottom layer metal.
- Vias are required under the backside paddle of this device for proper RF/DC grounding and thermal dissipation. We recommend a 0.35mm (#80/.0135") diameter bit for drilling via holes and a final plated thru diameter of 0.25mm (0.10").
- Ensure good package backside paddle solder attach for reliable operation and best electrical performance.
- Place mounting screws near the part to fasten a back side heat sink.
- Do not apply solder mask to the back side of the PC board in the heat sink contact region.
- Ensure that the backside via region makes good physical contact with the heat sink.

## Product Compliance Information

### ESD Sensitivity Ratings



Caution! ESD-Sensitive Device

ESD Rating: Class 1A  
Value:  $\geq 250$  V to  $< 500$  V  
Test: Human Body Model (HBM)  
Standard: ESDA/JEDEC Standard JS-001-2012

ESD Rating: Class C3  
Value:  $\geq 1000$  V  
Test: Charged Device Model (CDM)  
Standard: JEDEC Standard JESD22-C101F

### MSL Rating

MSL Rating: Level 3  
Test: 260 °C convection reflow  
Standard: JEDEC Standard IPC/JEDEC J-STD-020

### Solderability

Compatible with both lead-free (260 °C maximum reflow temperature) and tin/lead (245 °C maximum reflow temperature) soldering processes.

Contact plating: NiPdAu

### RoHS Compliance

This part is compliant with EU 2002/95/EC RoHS directive (Restrictions on the Use of Certain Hazardous Substances in Electrical and Electronic Equipment).

This product also has the following attributes:

- Lead Free
- Halogen Free (Chlorine, Bromine)
- Antimony Free
- TBBP-A (C<sub>15</sub>H<sub>12</sub>Br<sub>4</sub>O<sub>2</sub>) Free
- PFOS Free
- SVHC Free

## Contact Information

For the latest specifications, additional product information, worldwide sales and distribution locations:

Web: [www.triquint.com](http://www.triquint.com)      Tel: 877-800-8584  
Email: [customer.support@qorvo.com](mailto:customer.support@qorvo.com)

For information about the merger of RFMD and TriQuint as Qorvo:

Web: [www.qorvo.com](http://www.qorvo.com)

For technical questions and application information:

Email: [sjcapplcations.engineering@qorvo.com](mailto:sjcapplcations.engineering@qorvo.com)

## Important Notice

The information contained herein is believed to be reliable. TriQuint makes no warranties regarding the information contained herein. TriQuint assumes no responsibility or liability whatsoever for any of the information contained herein. TriQuint assumes no responsibility or liability whatsoever for the use of the information contained herein. The information contained herein is provided "AS IS, WHERE IS" and with all faults, and the entire risk associated with such information is entirely with the user. All information contained herein is subject to change without notice. Customers should obtain and verify the latest relevant information before placing orders for TriQuint products. The information contained herein or any use of such information does not grant, explicitly or implicitly, to any party any patent rights, licenses, or any other intellectual property rights, whether with regard to such information itself or anything described by such information.

TriQuint products are not warranted or authorized for use as critical components in medical, life-saving, or life-sustaining applications, or other applications where a failure would reasonably be expected to cause severe personal injury or death.