



AH101

Medium Power, High Linearity Amplifier

The Communications Edge™

Product Information

Product Features

- 50 – 1500 MHz
- +47 dBm Output IP3
- 13.5 dB Gain
- +26.5 dBm P1dB
- MTTF > 1000 Years
- Internally Matched
- Single +9 V Supply
- Lead-free/Green/RoHS-compliant SOT-89 Package

Applications

- Mobile Infrastructure
- CATV / DBS
- Defense / Homeland Security

Product Description

The AH101 is a medium power gain block that offers excellent dynamic range in a low-cost surface mount package. The combination of a single supply voltage and an internally matched device makes it ideal for both narrow and broadband applications. Only dc blocking and bypass capacitors as well as an RF choke are required for operation.

Superior thermal design allows the product to achieve +46 dBm IP3 performance at a mounting temperature of +85 °C with an associated MTTF of greater than 1000 years. The AH101 is available in the environmentally-friendly lead-free/green/RoHS-compliant SOT-89 package. The broadband amplifier uses a high reliability GaAs MESFET technology and is targeted for applications where high linearity is required.

Functional Diagram

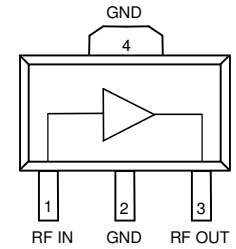

Function	Pin No.
Input	1
Ground	2
Output / Bias	3
Ground	4

Specifications ⁽¹⁾

Parameter	Units	Min	Typ	Max
Operational Bandwidth	MHz	50		1500
Test Frequency	MHz		800	
Gain	dB	12	13.5	
Input Return Loss	dB		20	
Output Return Loss	dB		15	
Output IP3 ⁽²⁾	dBm	+43	+47	
Output P1dB	dBm		+26.5	
Noise Figure	dB		3.5	
Operating Current Range	mA	170	200	230
Supply Voltage	V		+9	

1. Test conditions unless otherwise noted: T = 25 °C, V_{dd} = +9 V in a 50 ohm test fixture.
2. OIP3 is measured with two tones at an output power of +8 dBm/tone separated by 10 MHz. The suppression on the largest IM3 product is used to calculate the OIP3 using a 2:1 rule.

Typical Performance

Parameter	Units	Typical			
Frequency	MHz	50	450	900	1500
Gain	dB	13.6	13.8	13.5	12.7
S11	dB	-23	-27	-21	-14
S22	dB	-8	-14	-18	-16
Output P1dB	dBm	+26.1	+26.5	+26.5	+25
Output IP3 ⁽²⁾	dBm	+45	+47	+47	+47
Output IP2	dBm	+63	+63	+60	+59
Noise Figure	dB	4.4	3.4	3.6	4.2
Supply Current	mA		200		
Supply Voltage	V		+9		

Absolute Maximum Rating

Parameter	Rating
Operating Case Temperature	-40 to +85 °C
Storage Temperature	-55 to +150 °C
DC Voltage	+11 V
RF Input Power (continuous)	+18 dBm
Junction Temperature	220 °C

Operation of this device above any of these parameters may cause permanent damage.

Ordering Information

Part No.	Description
AH101-G	Med. Power High Linearity Amplifier (lead-free/green/RoHS-compliant SOT-89 Pkg)
AH101-PCB	50-1500 MHz Fully Assembled Evaluation Board

Specifications and information are subject to change without notice



Typical Device Data

$V_{DS} = +9\text{ V}$, $I_{DS} = 200\text{ mA}$, $T = 25\text{ }^\circ\text{C}$, unmatched 50 ohm system

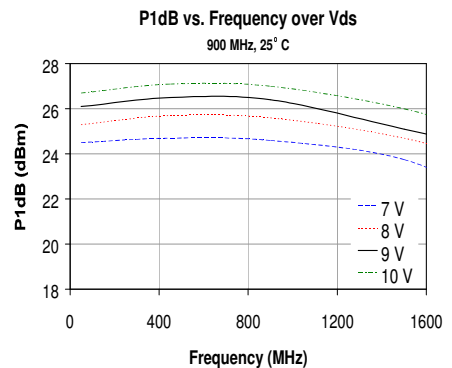
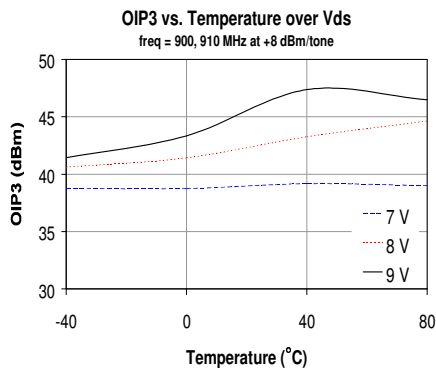
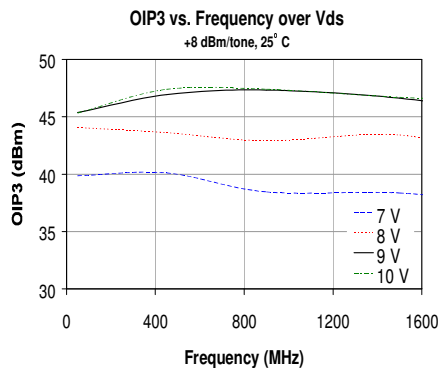
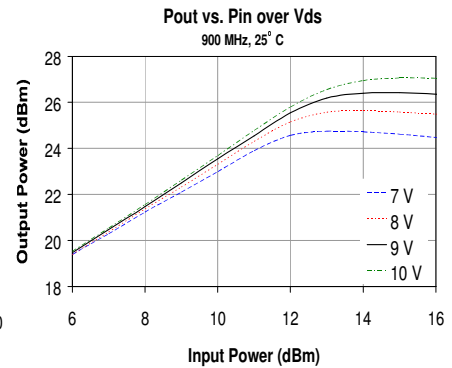
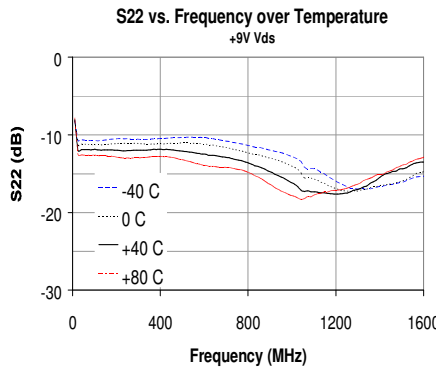
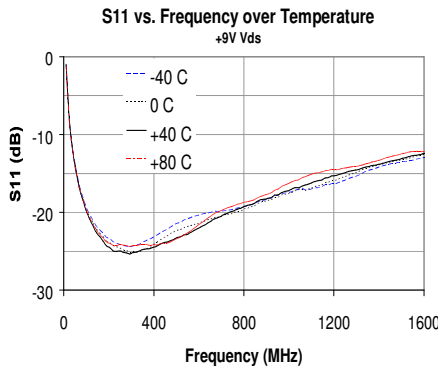
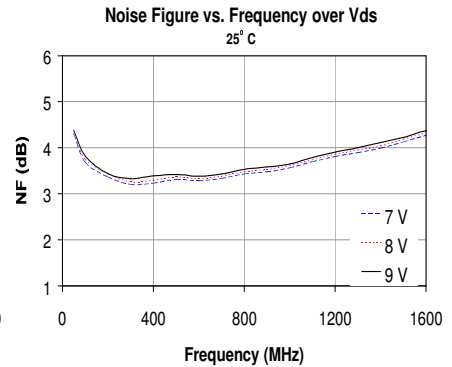
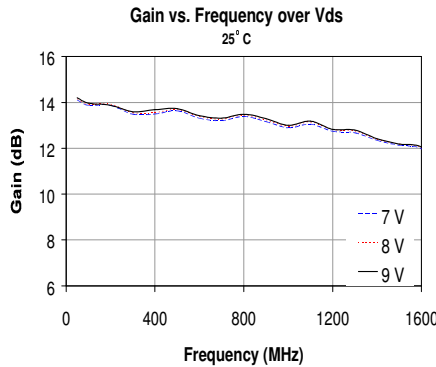
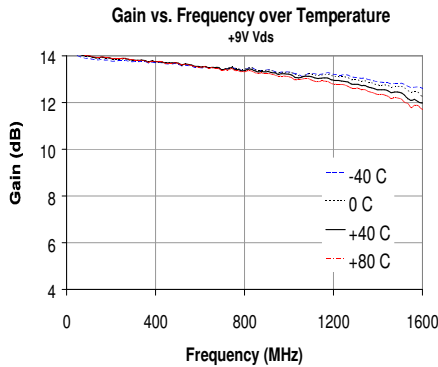

S-Parameters ($V_{DS} = +9\text{ V}$, $I_{DS} = 200\text{ mA}$, $T = 25\text{ }^\circ\text{C}$, unmatched 50 ohm system, calibrated to device leads)

Freq (MHz)	S11 (dB)	S11 (ang)	S21 (dB)	S21 (ang)	S12 (dB)	S12 (ang)	S22 (dB)	S22 (ang)
50	-18.92	-60.71	13.78	168.24	-19.25	4.11	-14.51	-160.07
100	-22.31	-52.06	13.63	169.87	-19.13	0.17	-14.86	-177.29
200	-23.85	-47.09	13.50	166.42	-19.17	-5.09	-15.22	164.61
400	-23.32	-62.31	13.48	157.06	-19.28	-12.63	-14.83	140.14
600	-21.73	-77.34	13.32	146.40	-19.36	-19.07	-14.55	118.64
800	-20.76	-90.04	13.19	135.74	-19.47	-25.94	-14.02	97.71
1000	-19.65	-105.39	13.05	124.67	-19.74	-33.10	-13.40	80.17
1200	-18.62	-121.62	12.94	114.96	-20.07	-39.77	-12.95	63.09
1400	-17.32	-131.81	12.76	104.01	-20.36	-45.37	-12.44	47.65
1600	-16.53	-141.33	12.55	93.98	-20.44	-53.24	-12.02	31.14



Application Circuit PC Board Layout

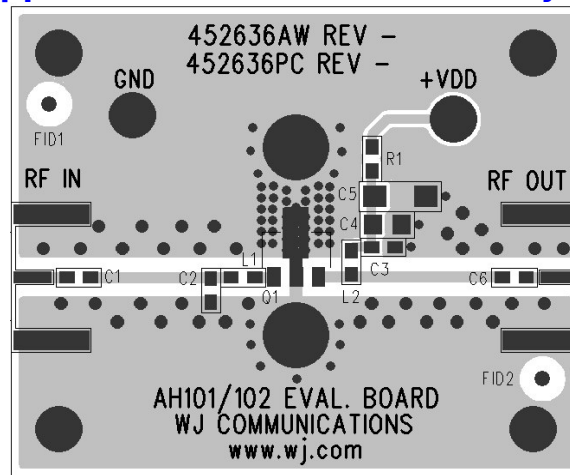

Circuit Board Material: .014" Getek ($\epsilon_r=4.2$), four layer, 1 oz copper
Microstrip line details: width = .026", spacing = .026"

Application Circuit: 900 MHz (AH101-PCB)

Typical RF Performance at 25°C

Frequency	Units	50	450	900	1500
Gain	dB	13.6	13.8	13.5	12.7
S11	dB	-23	-27	-21	-14
S22	dB	-8	-14	-18	-16
Output P1dB	dBm	+26.1	+26.5	+26.5	+25
Output IP3 ⁽²⁾	dBm	+45	+47	+47	+47
Output IP2	dBm	+63	+63	+60	+59
Noise Figure	dB	4.4	3.4	3.6	4.2
Supply Voltage	V	9			
Supply Current	mA	200			

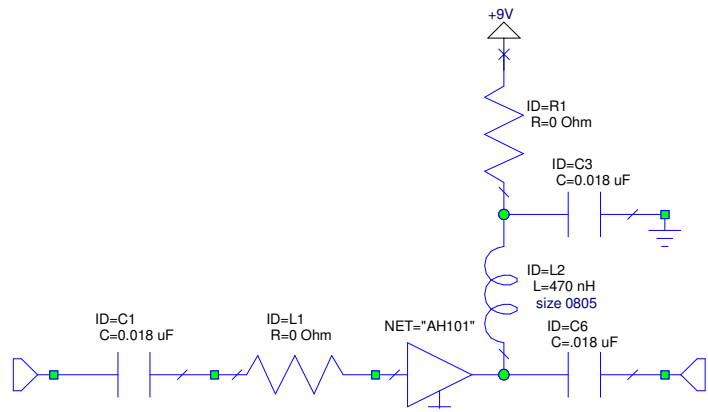

Notes:

1. The amplifier should be connected directly to a +9 V regulator; no dropping resistor is required.
2. If no DC signal is present at the input (pin 1), C1 can be removed. The gate (input pin) is internally grounded in the amplifier.
3. R1, C2, and L1 are used as placeholders for a different device on the same PCB layout. They are not needed for the AH101.
3. Component sizes are 0603 unless otherwise noted.

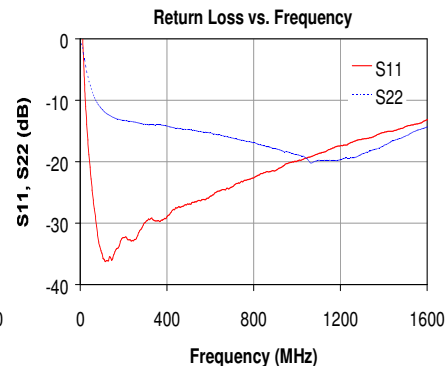
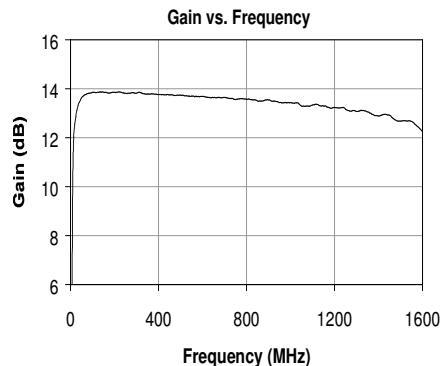



AH101 CATV Push-Pull Reference Design

Frequency	MHz	50	450	750	860
S21	dB	11.4	10.8	10.4	10.2
S11	dB	-17	-19	-19	-25
S22	dB	-17	-20	-16	-14
OIP2 ⁽²⁾	dBm	84			
OIP3 ⁽³⁾	dBm				50
Noise Figure	dB	6	5.1	5.3	5.4
CSO ⁽⁴⁾	dBc	-83.3			
CTB ⁽⁴⁾	dBc	-68.6			
Supply Bias		9 V @ 200 mA			

Notes:

- Parameters reflect performance in the 75Ω push-pull application circuit.
- OIP2 is measured with +17 dBm at the fundamental.
- OIP3 is measured with 2 tones at +17 dBm/tone with 10 MHz spacing.
- 77 Channels Flat Loading, Pin = 34 dBmV / channel.

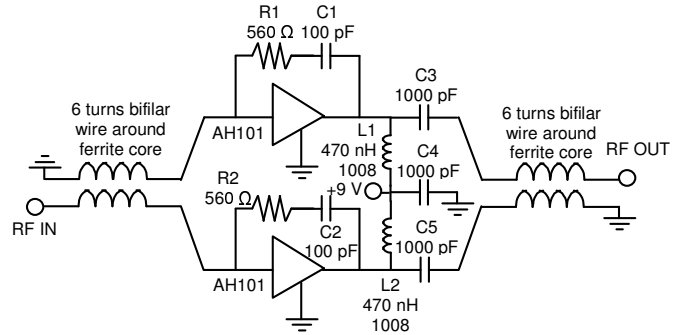

FR4 Board Layout (T=28 mils to ground plane)

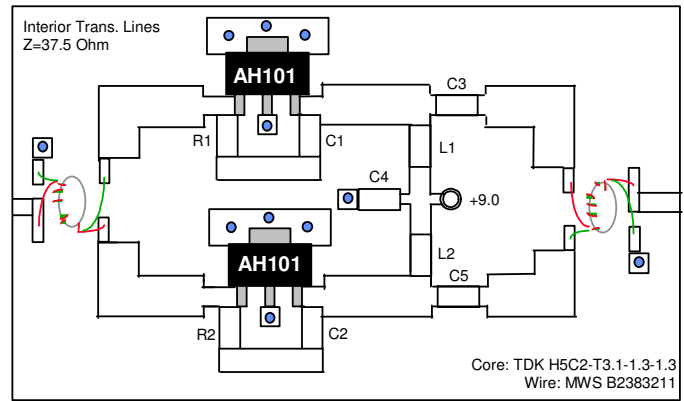

The AH101 should be thermally mounted according to what is shown in the datasheet.

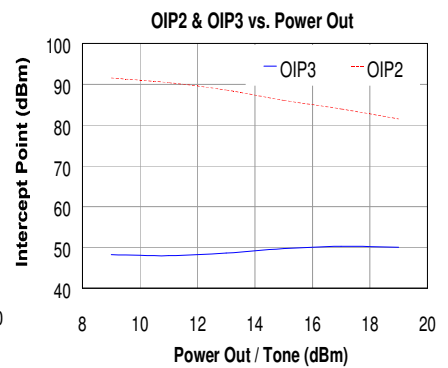
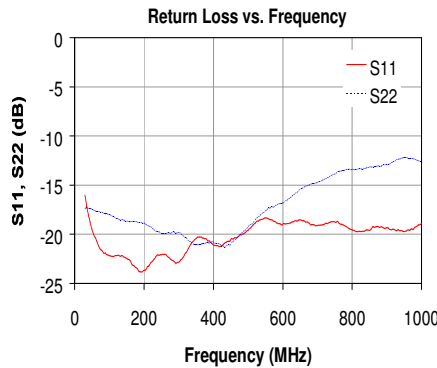
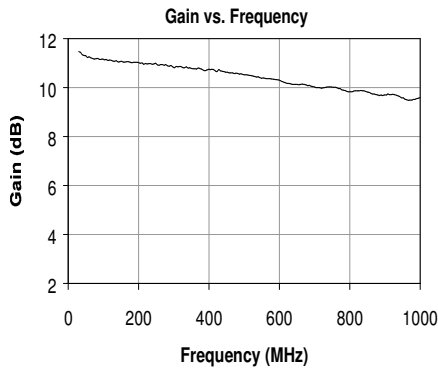



AH101-G (Green / Lead-free SOT-89 Package) Mechanical Information

This package is lead-free/Green/RoHS-compliant. It is compatible with both lead-free (maximum 260 °C reflow temperature) and leaded (maximum 245 °C reflow temperature) soldering processes. The plating material on the leads is NiPdAu.

Outline Drawing

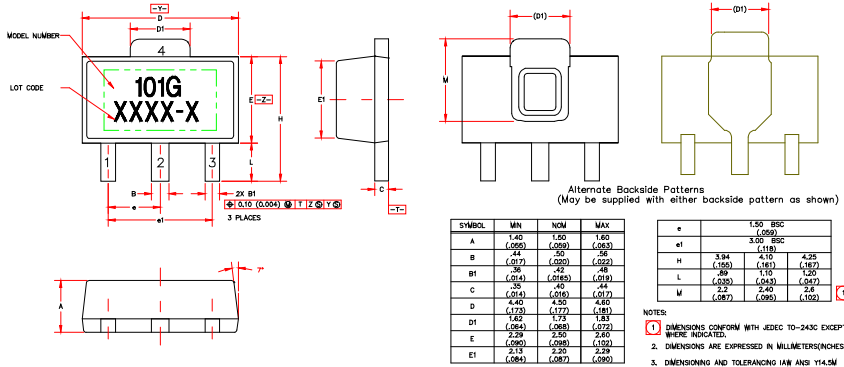

Product Marking

The AH101-G will be marked with an "101G" designator. An alphanumeric lot code ("XXXX-X") is also marked below the part designator on the top surface of the package. The obsolete tin-lead package is marked with an "AH101" designator followed by an alphanumeric lot code.

Tape and reel specifications for this part are located on the website in the "Application Notes" section.

Land Pattern

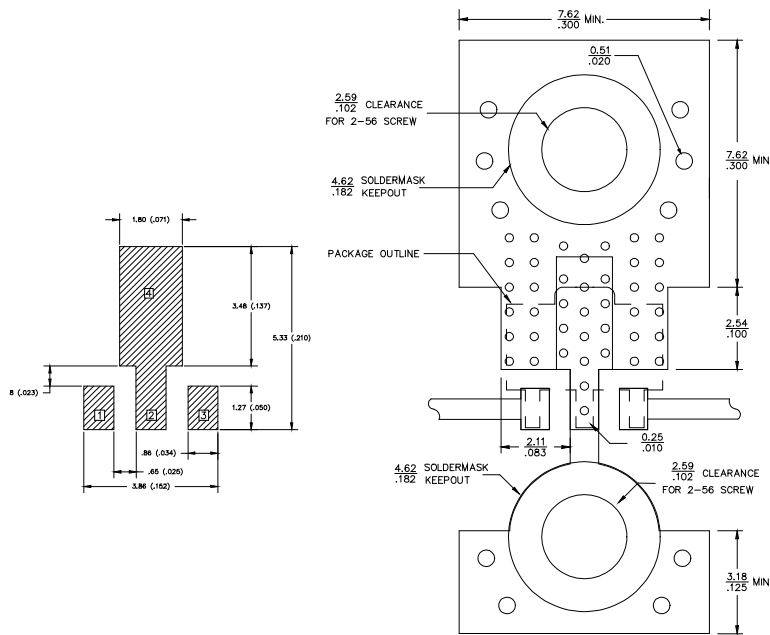

MSL / ESD Rating



Caution! ESD sensitive device.

ESD Rating: Class 1C
 Value: Passes ≥ 1000V min.
 Test: Human Body Model (HBM)
 Standard: JEDEC Standard JESD22-A114

ESD Rating: Class IV
 Value: Passes ≥ 1000V min.
 Test: Charged Device Model (CDM)
 Standard: JEDEC Standard JESD22-C101

MSL Rating: Level 3 at +260 °C convection reflow
 Standard: JEDEC Standard J-STD-020

Mounting Config. Notes

1. Ground / thermal vias are critical for the proper performance of this device. Vias should use a .35mm (#80 / .0135") diameter drill and have a final plated thru diameter of .25 mm (.010").
2. Add as much copper as possible to inner and outer layers near the part to ensure optimal thermal performance.
3. Mounting screws can be added near the part to fasten the board to a heatsink. Ensure that the ground / thermal via region contacts the heatsink.
4. Do not put solder mask on the backside of the PC board in the region where the board contacts the heatsink.
5. RF trace width depends upon the PC board material and construction.
6. Use 1 oz. Copper minimum.
7. All dimensions are in millimeters (inches). Angles are in degrees.

Thermal Specifications

Parameter	Rating
Operating Case Temperature	-40 to +85 °C
Thermal Resistance, Rth ⁽¹⁾	25 °C / W
Junction Temperature, Tj ⁽²⁾	130 °C

1. The thermal resistance is referenced from the hottest part of the junction to the ground tab (pin 4).
2. This corresponds to the typical biasing condition of +9V, 200 mA at an 85 °C case temperature. A minimum MTTF of 1 million hours is achieved for junction temperatures below 160 °C.

