

REV.	DATE	ECN NO.	MODIFICATION	APPROVER
A	2008/09/20	/	NEW	Vicky

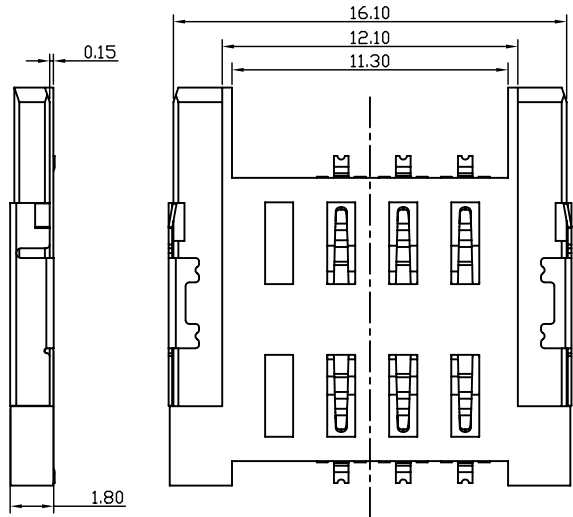

- Remarks:
- Material:
    - Housing: LCP UL94V-0
    - Terminal: Phosphor bronze, nickel groud 50",  
Gold 1u" on contact area plating
    - Shell: SUS, nickel groud 50u",  
Gold 1u" at solder tail
  - Main Performance:
    - Rated current: 0.5A
    - Contact resistance: 50mΩ MAX
    - Insulation resistance: 100MΩ MIN 100V DC
    - Withstanding voltage test: 100V AC
    - Solderability: temperature 235±5°C, time 5±0.5s
    - Terminal retention force: 0.035kgf MIN
    - Life cycle: 5000times
    - Withstanding temperature:  
oven test: temperature 250±5°C, 2 minutes
    - Operating environment: temperature: -30°C~+80°C;  
humidity: 80% MAX

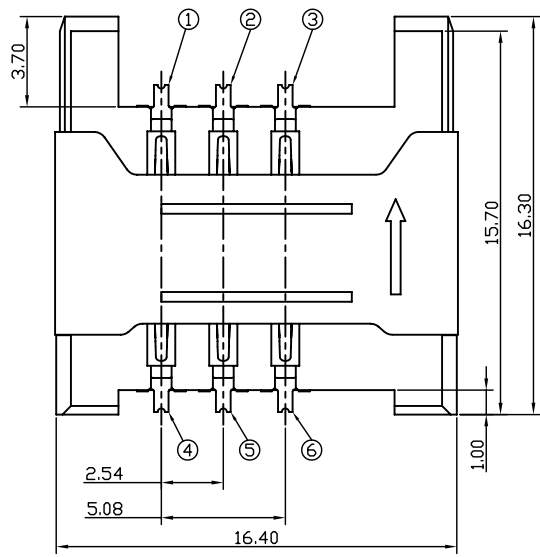
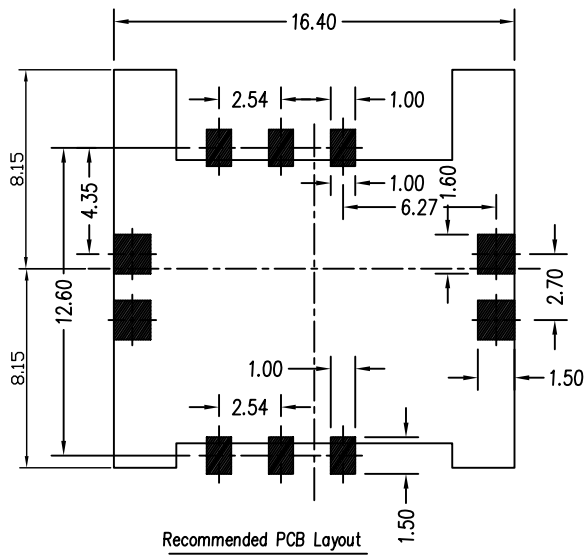
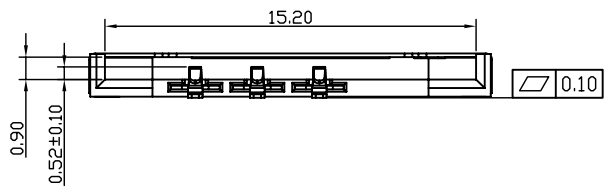

PIN 脚 定 义					
第1PIN	第2PIN	第3PIN	第4PIN	第5PIN	第6PIN
VCC	RESET	CLK	GND	VPP	IO