

- Meets IEEE Standard 488-1978 (GPIB)
- 8-Channel Bidirectional Transceiver
- Power-Up/Power-Down Protection (Glitch Free)
- High-Speed, Low-Power Schottky Circuitry
- Low Power Dissipation . . . 72 mW Max Per Channel
- Fast Propagation Times . . . 22 ns Max
- High-Impedance pnp Inputs
- Receiver Hysteresis . . . 650 mV Typ
- Open-Collector Driver Output Option
- No Loading of Bus When Device Is Powered Down ( $V_{CC} = 0$ )

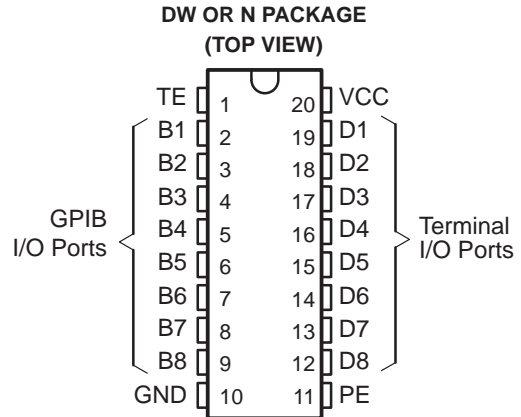

### description

The SN75160B 8-channel general-purpose interface bus (GPIB) transceiver is a monolithic, high-speed, low-power Schottky device designed for two-way data communications over single-ended transmission lines. It is designed to meet the requirements of IEEE Standard 488-1978. The transceiver features driver outputs that can be operated in either the passive-pullup or 3-state mode. If talk enable (TE) is high, these ports have the characteristics of passive-pullup outputs when pullup enable (PE) is low and of 3-state outputs when PE is high. Taking TE low places these ports in the high-impedance state. The driver outputs are designed to handle loads up to 48 mA of sink current.

Output glitches during power up and power down are eliminated by an internal circuit that disables both the bus and receiver outputs. The outputs do not load the bus when  $V_{CC} = 0$ . When combined with the SN75161B or SN75162B management bus transceivers, the pair provides the complete 16-wire interface for the IEEE-488 bus.

The SN75160B is characterized for operation from 0°C to 70°C.

### Function Tables

EACH DRIVER			
INPUTS			OUTPUT
D	TE	PE	B
H	H	H	H
L	H	X	L
H	X	L	Z†
X	L	X	Z†

EACH RECEIVER			
INPUTS			OUTPUT
B	TE	PE	D
L	L	X	L
H	L	X	H
X	H	X	Z

H = high level, L = low level, X = irrelevant, Z = high impedance

† This is the high-impedance state of a normal 3-state output modified by the internal resistors to  $V_{CC}$  and GND.



Please be aware that an important notice concerning availability, standard warranty, and use in critical applications of Texas Instruments semiconductor products and disclaimers thereto appears at the end of this data sheet.

**SN75160B**  
**OCTAL GENERAL-PURPOSE**  
**INTERFACE BUS TRANSCEIVER**  
 SLLS004B – OCTOBER 1985 – REVISED MAY 1995

logic symbol†

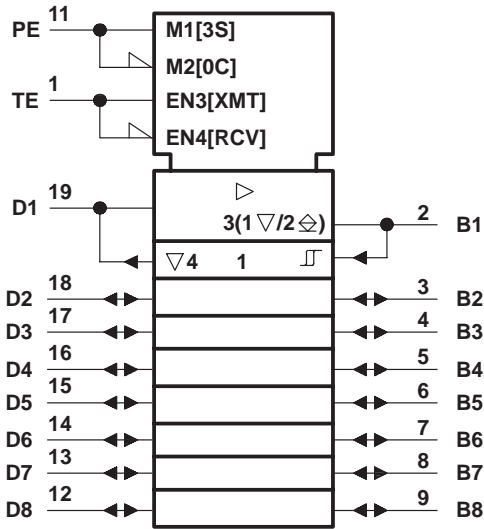

† This symbol is in accordance with ANSI/IEEE Std 91-1984 and IEC Publication 617-12.  
 ▽ Designates 3-state outputs  
 ◇ Designates passive-pullup outputs

logic diagram (positive logic)

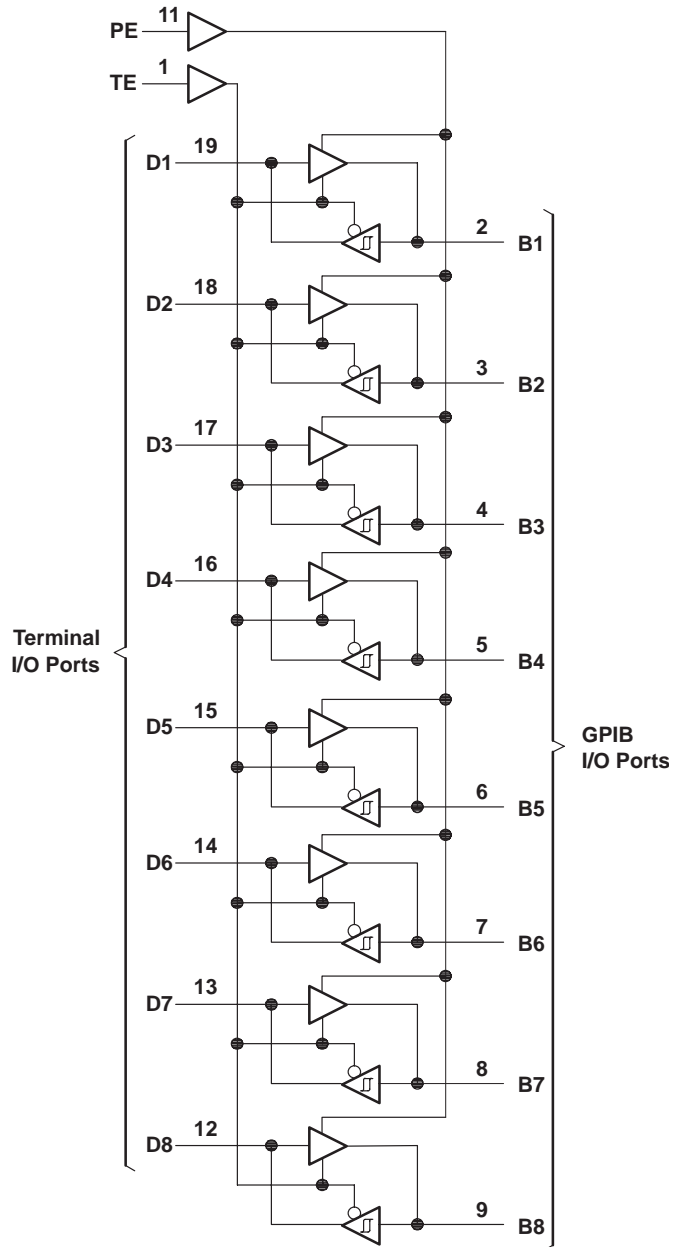

**schematics of inputs and outputs**

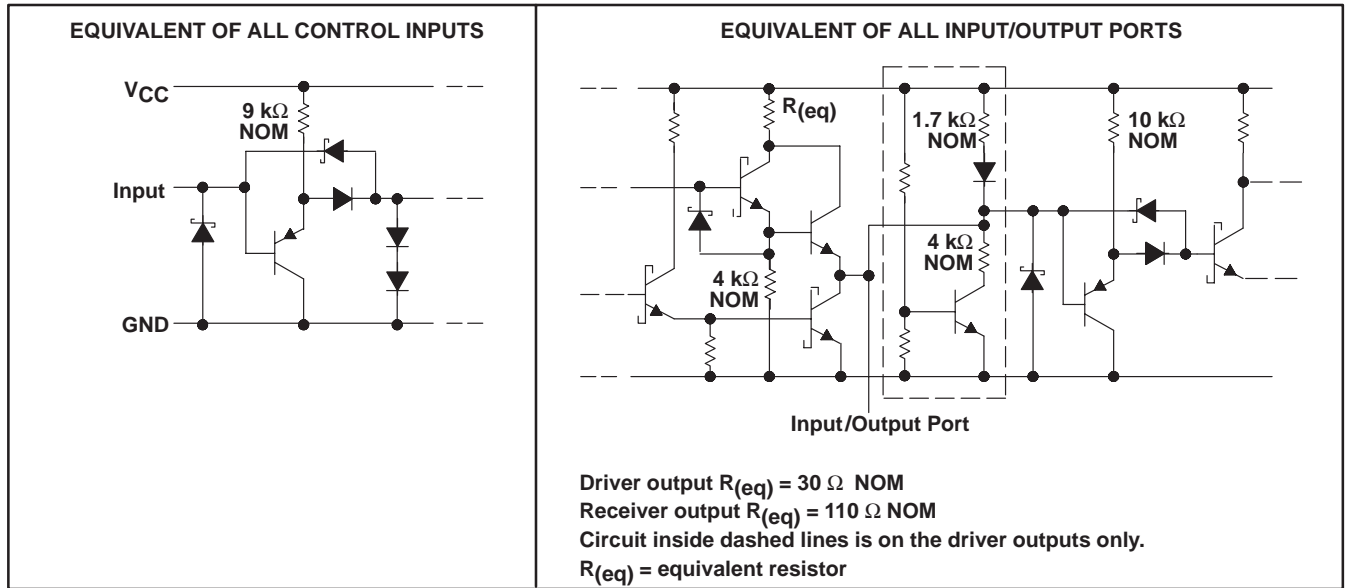

**absolute maximum ratings over operating free-air temperature range (unless otherwise noted)†**

Supply voltage, $V_{CC}$ (see Note 1)	7 V
Input voltage, $V_I$	5.5 V
Low-level driver output current, $I_{OL}$	100 mA
Continuous total power dissipation	See Dissipation Rating Table
Operating free-air temperature range, $T_A$	0°C to 70°C
Storage temperature range, $T_{stg}$	-65°C to 150°C
Lead temperature 1,6 mm (1/16 inch) from case for 10 seconds	260°C

† Stresses beyond those listed under "absolute maximum ratings" may cause permanent damage to the device. These are stress ratings only, and functional operation of the device at these or any other conditions beyond those indicated under "recommended operating conditions" is not implied. Exposure to absolute-maximum-rated conditions for extended periods may affect device reliability.

NOTES: 1. All voltage values are with respect to network ground terminal.

**DISSIPATION RATING TABLE**

PACKAGE	$T_A \leq 25^\circ\text{C}$ POWER RATING	DERATING FACTOR ABOVE $T_A = 25^\circ\text{C}$	$T_A = 70^\circ\text{C}$ POWER RATING
DW	1125 mW	9.0 mW/°C	720 mW
N	1150 mW	9.2 mW/°C	736 mW

**SN75160B**  
**OCTAL GENERAL-PURPOSE**  
**INTERFACE BUS TRANSCEIVER**

SLLS004B – OCTOBER 1985 – REVISED MAY 1995

**recommended operating conditions**

		MIN	NOM	MAX	UNIT
Supply voltage, $V_{CC}$		4.75	5	5.25	V
High-level input voltage, $V_{IH}$		2			V
Low-level input voltage, $V_{IL}$				0.8	V
High-level output current, $I_{OH}$	Bus ports with pullups active			-5.2	mA
	Terminal ports			-800	$\mu$ A
Low-level output current, $I_{OL}$	Bus ports			48	mA
	Terminal ports			16	
Operating free-air temperature, $T_A$		0		70	$^{\circ}$ C

**electrical characteristics over recommended ranges of supply voltage and operating free-air temperature (unless otherwise noted)**

PARAMETER		TEST CONDITIONS		MIN	TYP†	MAX	UNIT
$V_{IK}$	Input clamp voltage	$I_I = -18$ mA		-0.8	-1.5		V
$V_{hys}$	Hysteresis voltage ( $V_{IT+} - V_{IT-}$ )	Bus	See Figure 8	0.4	0.65		V
$V_{OH}$	High-level output voltage	Terminal	$I_{OH} = -800$ $\mu$ A, TE at 0.8 V	2.7	3.5		V
		Bus	$I_{OH} = -5.2$ mA, PE and TE at 2 V	2.5	3.3		
$V_{OL}$	Low-level output voltage	Terminal	$I_{OL} = 16$ mA, TE at 0.8 V	0.3	0.5		V
		Bus	$I_{OL} = 48$ mA, TE at 2 V	0.35	0.5		
$I_I$	Input current at maximum input voltage	Terminal	$V_I = 5.5$ V		0.2	100	$\mu$ A
$I_{IH}$	High-level input current	Terminal	$V_I = 2.7$ V		0.1	20	$\mu$ A
$I_{IL}$	Low-level input current	Terminal	$V_I = 0.5$ V		-10	-100	$\mu$ A
$V_{I/O}(\text{bus})$	Voltage at bus port	Driver disabled	$I_I(\text{bus}) = 0$	2.5	3.0	3.7	V
			$I_I(\text{bus}) = -12$ mA			-1.5	
$I_{I/O}(\text{bus})$	Current into bus port	Power on	Driver disabled	$V_I(\text{bus}) = -1.5$ V to 0.4 V	-1.3		mA
				$V_I(\text{bus}) = 0.4$ V to 2.5 V	0	-3.2	
				$V_I(\text{bus}) = 2.5$ V to 3.7 V		2.5	
				$V_I(\text{bus}) = 3.7$ V to 5 V	0	2.5	
				$V_I(\text{bus}) = 5$ V to 5.5 V	0.7	2.5	
		Power off	$V_{CC} = 0$ , $V_I(\text{bus}) = 0$ to 2.5 V		-40		
$I_{OS}$	Short-circuit output current	Terminal		-15	-35	-75	mA
		Bus		-25	-50	-125	
$I_{CC}$	Supply current	No load	Receivers low and enabled		70	90	mA
			Drivers low and enabled		85	110	
$C_{I/O}(\text{bus})$	Bus-port capacitance	$V_{CC} = 0$ to 5 V, $V_{I/O} = 0$ to 2 V, $f = 1$ MHz			16		pF

† All typical values are at  $V_{CC} = 5$  V,  $T_A = 25^{\circ}$ C.



**switching characteristics,  $V_{CC} = 5\text{ V}$ ,  $C_L = 15\text{ pF}$ ,  $T_A = 25^\circ\text{C}$  (unless otherwise noted)**

PARAMETER		FROM (INPUT)	TO (OUTPUT)	TEST CONDITIONS	MIN	TYP	MAX	UNIT
$t_{PLH}$	Propagation delay time, low- to high-level output	Terminal	Bus	$C_L = 30\text{ pF}$ , See Figure 1		14	20	ns
$t_{PHL}$	Propagation delay time, high- to low-level output					14	20	
$t_{PLH}$	Propagation delay time, low- to high-level output	Bus	Terminal	$C_L = 30\text{ pF}$ , See Figure 2		10	20	ns
$t_{PHL}$	Propagation delay time, high- to low-level output					15	22	
$t_{PZH}$	Output enable time to high level	TE	BUS	See Figure 3		25	35	ns
$t_{PHZ}$	Output disable time from high level					13	22	
$t_{PZL}$	Output enable time to low level					22	35	
$t_{PLZ}$	Output disable time from low level					22	32	
$t_{PZH}$	Output enable time to high level	TE	Terminal	See Figure 4		20	30	ns
$t_{PHZ}$	Output disable time from high level					12	20	
$t_{PZL}$	Output enable time to low level					23	32	
$t_{PLZ}$	Output disable time from low level					19	30	
$t_{en}$	Output pullup enable time	PE	Bus	See Figure 5		15	22	ns
$t_{dis}$	Output pullup disable time					13	20	

**PARAMETER MEASUREMENT INFORMATION**

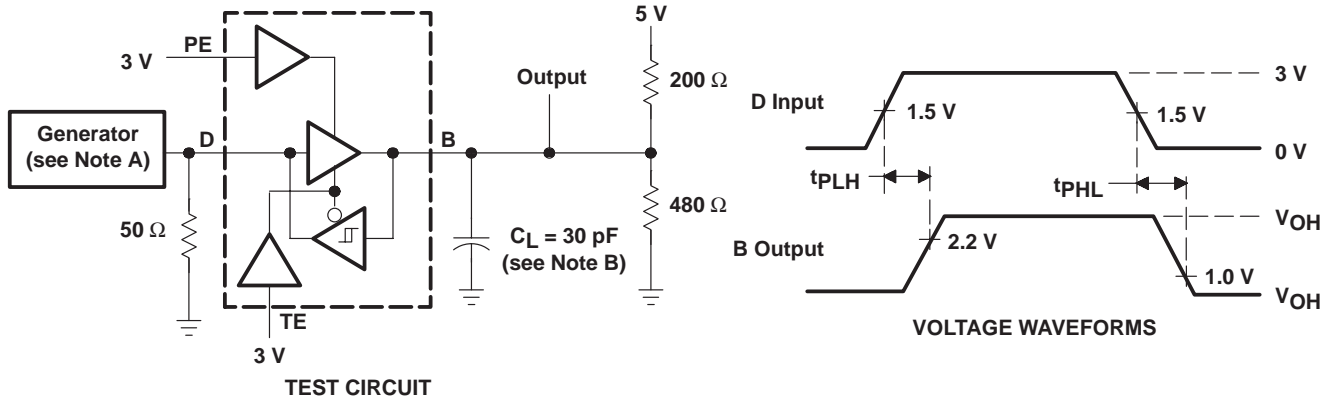

- NOTES: A. The input pulse is supplied by a generator having the following characteristics: PRR  $\leq$  1 MHz, 50% duty cycle,  $t_r \leq$  6 ns,  $t_f \leq$  ns,  $Z_O = 50 \Omega$ .  
 B.  $C_L$  includes probe and jig capacitance.

**Figure 1. Terminal-to-Bus Test Circuit and Voltage Waveforms**

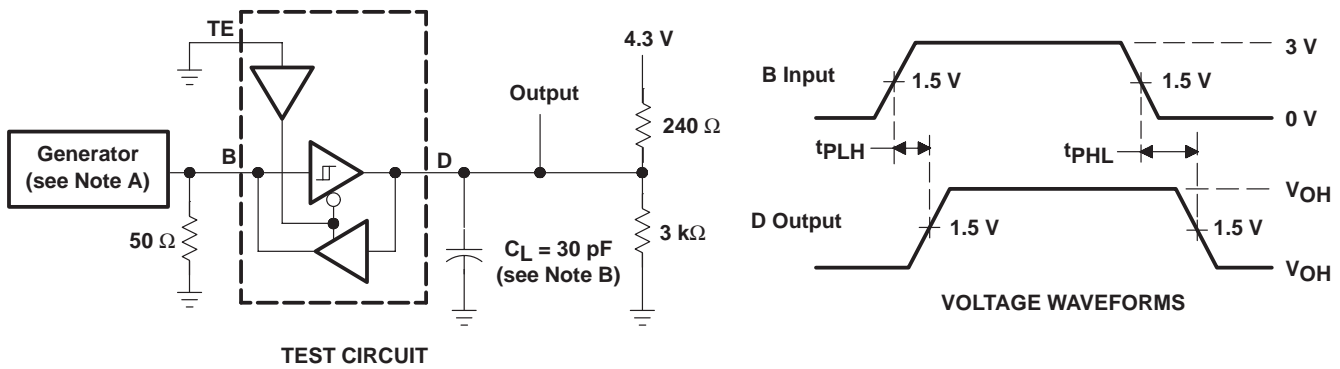

- NOTES: A. The input pulse is supplied by a generator having the following characteristics: PRR  $\leq$  1 MHz, 50% duty cycle,  $t_r \leq$  6 ns,  $t_f \leq$  ns,  $Z_O = 50 \Omega$ .  
 B.  $C_L$  includes probe and jig capacitance.

**Figure 2. Bus-to-Terminal Test Circuit and Voltage Waveforms**

**PARAMETER MEASUREMENT INFORMATION**

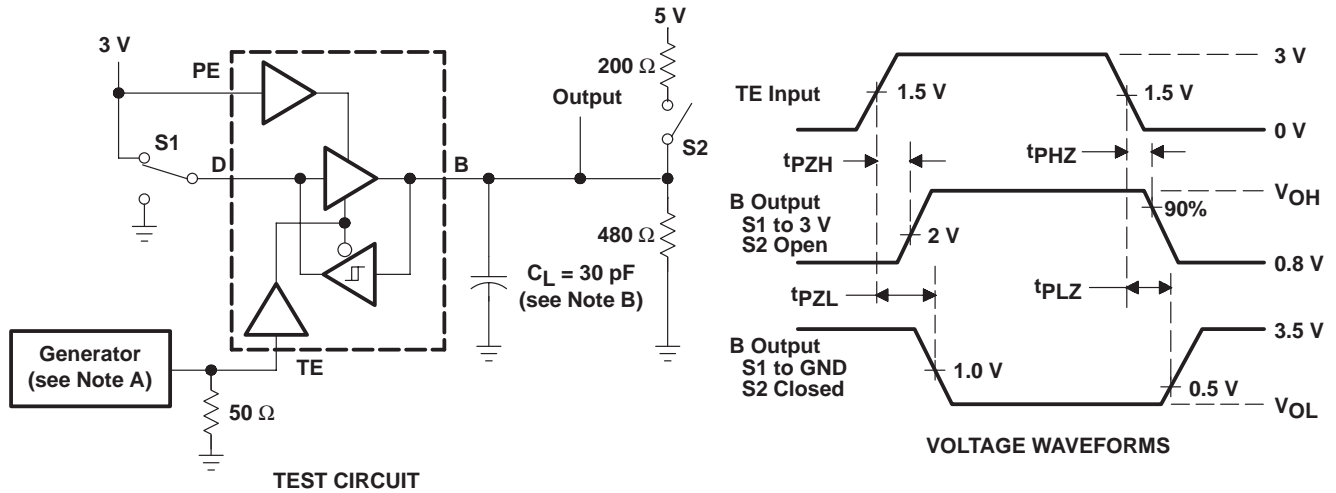

- NOTES: A. The input pulse is supplied by a generator having the following characteristics:  $PRR \leq 1$  MHz, 50% duty cycle,  $t_r \leq 6$  ns,  $t_f \leq$  ns,  $Z_O = 50 \Omega$ .  
B.  $C_L$  includes probe and jig capacitance.

**Figure 3. TE-to-Bus Test Circuit and Voltage Waveforms**

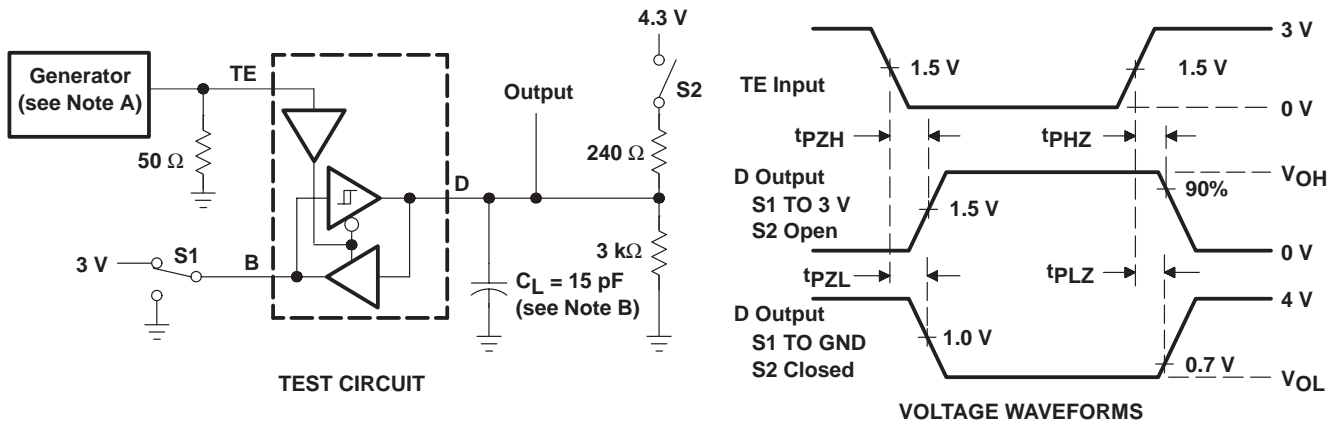

- NOTES: A. The input pulse is supplied by a generator having the following characteristics:  $PRR \leq 1$  MHz, 50% duty cycle,  $t_r \leq 6$  ns,  $t_f \leq$  ns,  $Z_O = 50 \Omega$ .  
B.  $C_L$  includes probe and jig capacitance.

**Figure 4. TE-to-Terminal Test Circuit and Voltage Waveforms**

PARAMETER MEASUREMENT INFORMATION

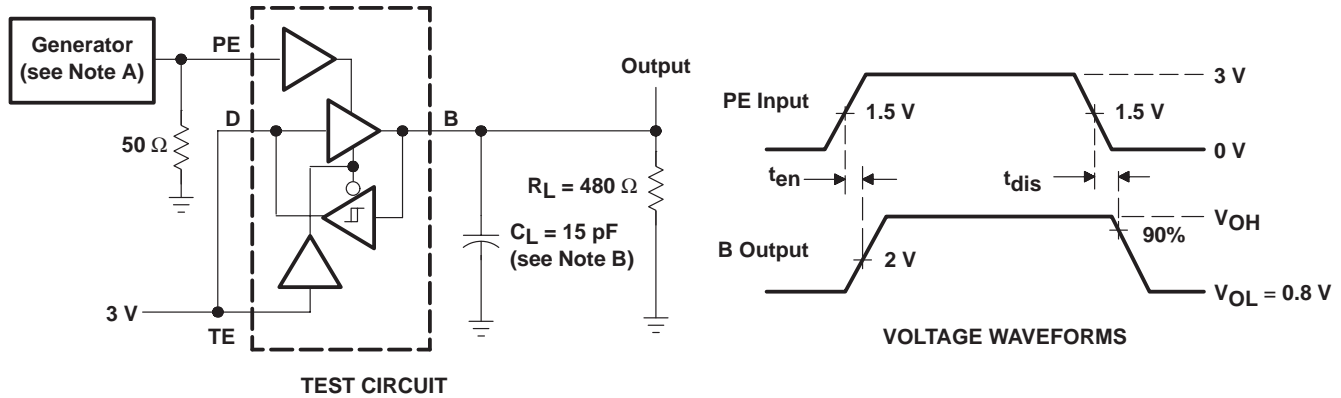

- NOTES: A. The input pulse is supplied by a generator having the following characteristics: PRR  $\leq$  1 MHz, 50% duty cycle,  $t_r \leq$  6 ns,  $t_f \leq$  ns,  $Z_0 = 50 \Omega$ .
- B.  $C_L$  includes probe and jig capacitance.

Figure 5. PE-to-Bus Pullup Test Circuit and Voltage Waveforms



**TYPICAL CHARACTERISTICS**

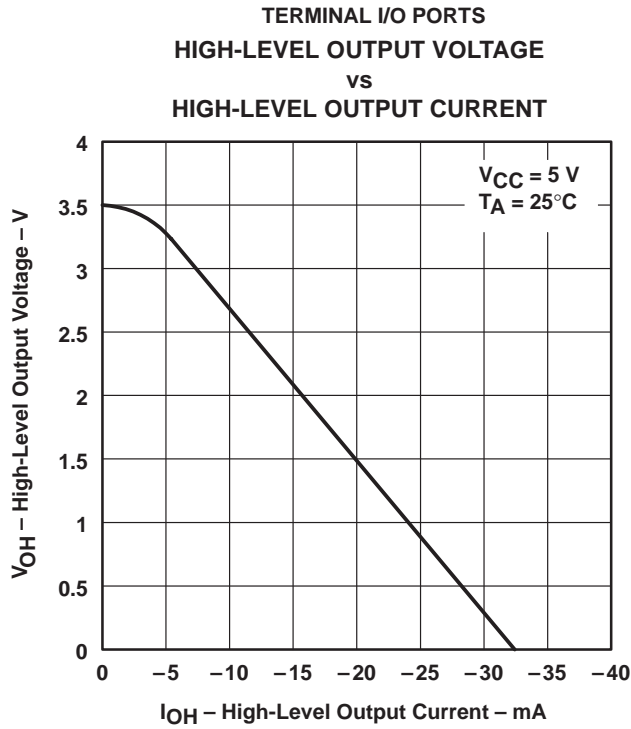

Figure 6

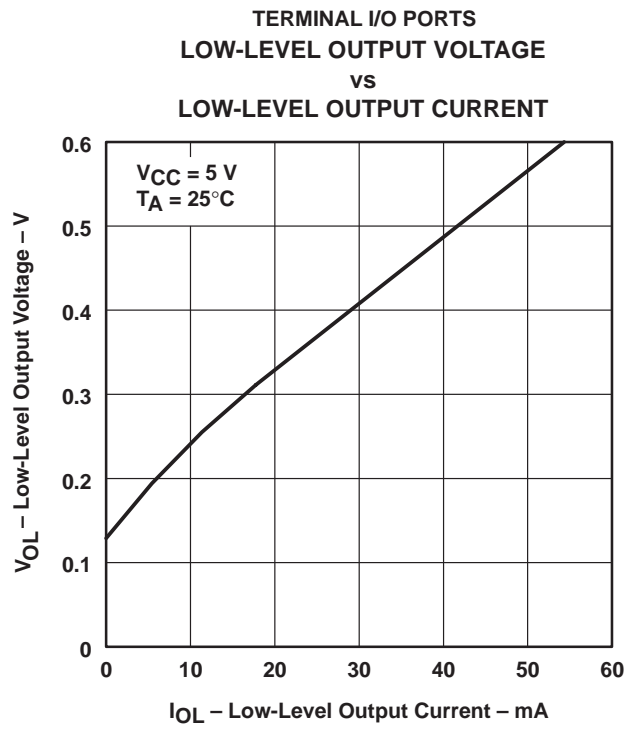

Figure 7

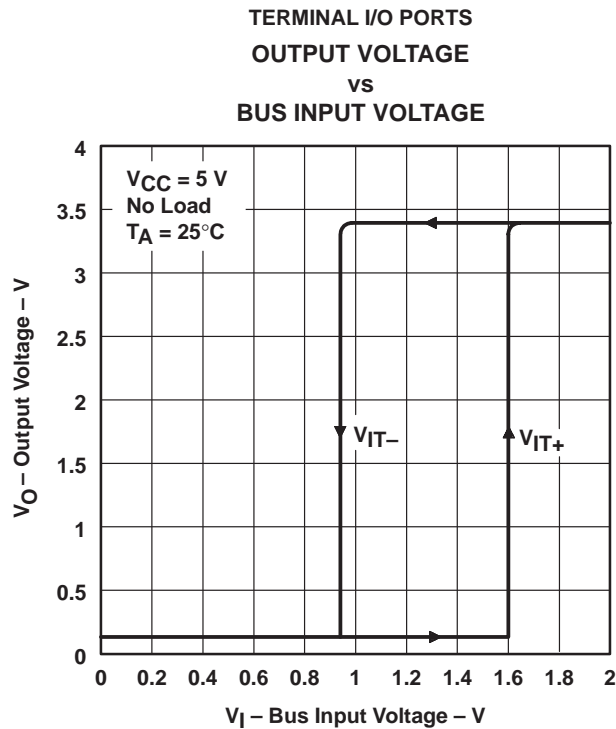

Figure 8

TYPICAL CHARACTERISTICS

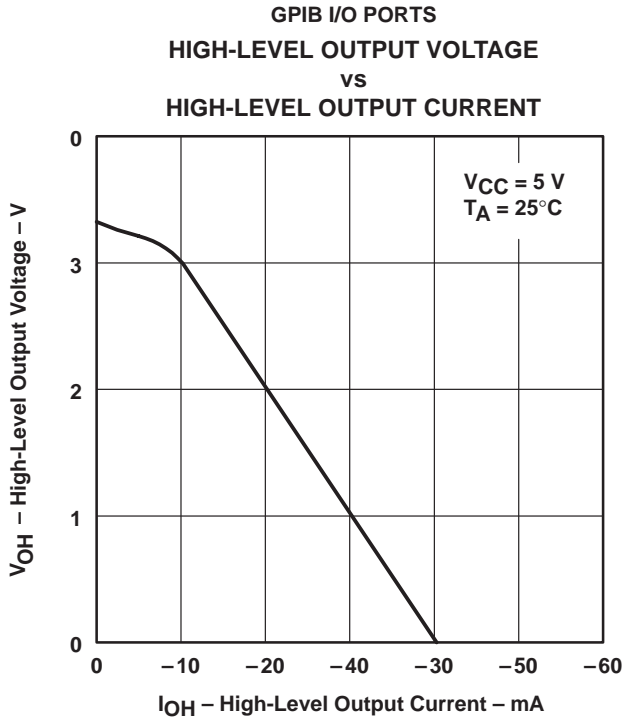

Figure 9

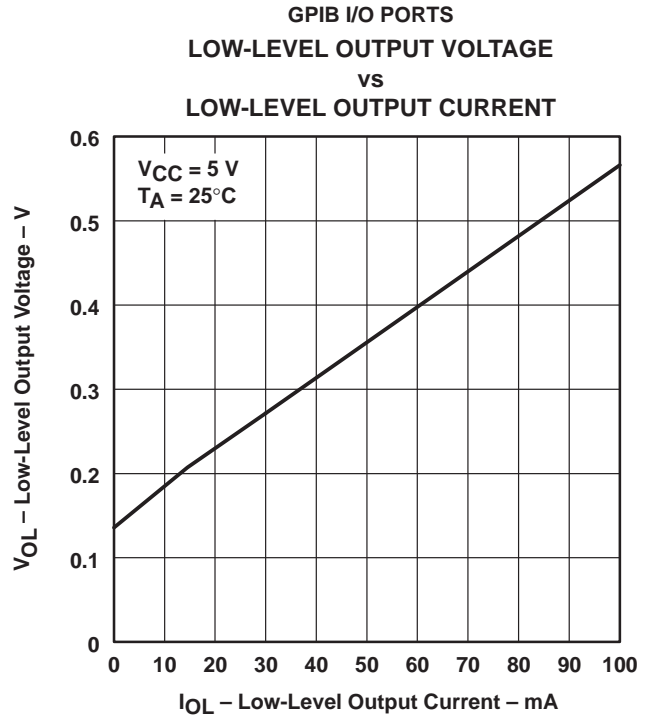

Figure 10

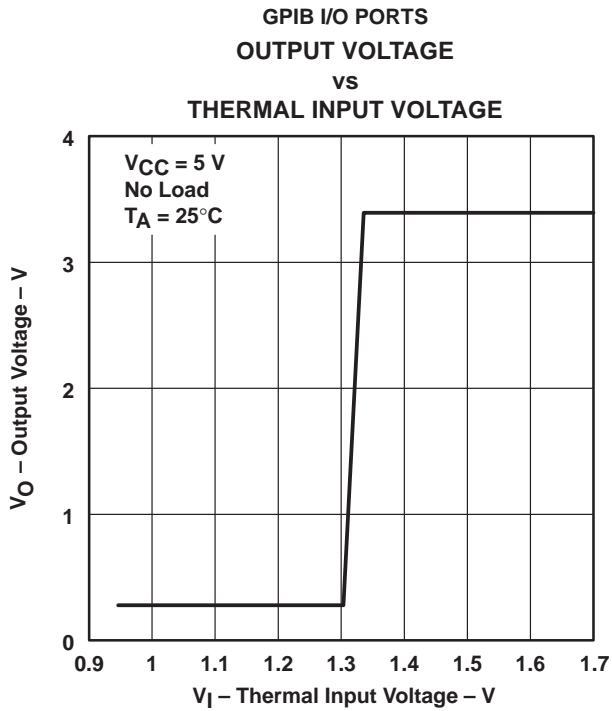

Figure 11

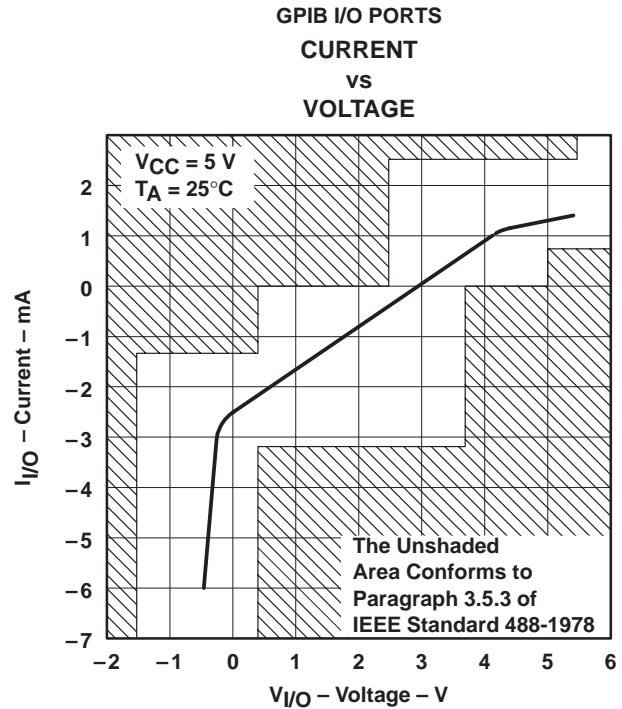

Figure 12

## IMPORTANT NOTICE

Texas Instruments and its subsidiaries (TI) reserve the right to make changes to their products or to discontinue any product or service without notice, and advise customers to obtain the latest version of relevant information to verify, before placing orders, that information being relied on is current and complete. All products are sold subject to the terms and conditions of sale supplied at the time of order acknowledgement, including those pertaining to warranty, patent infringement, and limitation of liability.

TI warrants performance of its semiconductor products to the specifications applicable at the time of sale in accordance with TI's standard warranty. Testing and other quality control techniques are utilized to the extent TI deems necessary to support this warranty. Specific testing of all parameters of each device is not necessarily performed, except those mandated by government requirements.

CERTAIN APPLICATIONS USING SEMICONDUCTOR PRODUCTS MAY INVOLVE POTENTIAL RISKS OF DEATH, PERSONAL INJURY, OR SEVERE PROPERTY OR ENVIRONMENTAL DAMAGE ("CRITICAL APPLICATIONS"). TI SEMICONDUCTOR PRODUCTS ARE NOT DESIGNED, AUTHORIZED, OR WARRANTED TO BE SUITABLE FOR USE IN LIFE-SUPPORT DEVICES OR SYSTEMS OR OTHER CRITICAL APPLICATIONS. INCLUSION OF TI PRODUCTS IN SUCH APPLICATIONS IS UNDERSTOOD TO BE FULLY AT THE CUSTOMER'S RISK.

In order to minimize risks associated with the customer's applications, adequate design and operating safeguards must be provided by the customer to minimize inherent or procedural hazards.

TI assumes no liability for applications assistance or customer product design. TI does not warrant or represent that any license, either express or implied, is granted under any patent right, copyright, mask work right, or other intellectual property right of TI covering or relating to any combination, machine, or process in which such semiconductor products or services might be or are used. TI's publication of information regarding any third party's products or services does not constitute TI's approval, warranty or endorsement thereof.