

# SN54HC257, SN54HC258, SN74HC257, SN74HC258 QUAD 2-LINE TO 1-LINE DATA SELECTORS/MULTIPLEXERS WITH 3-STATE OUTPUTS

SCLS224 D2684, DECEMBER 1982—REVISED JUNE 1989

- High-Current 3-State Outputs Interface Directly with System Bus or Can Drive Up to 15 LSTTL Loads
- Provides Bus Interface from Multiple Sources in High Performance Systems
- Package Options Include Plastic "Small Outline" Packages, Ceramic Chip Carriers, and Standard Plastic and Ceramic 300-mil DIPs
- Dependable Texas Instruments Quality and Reliability

SN54HC257, SN54HC258 . . . J PACKAGE  
SN74HC257, SN74HC258 . . . D<sup>†</sup> OR N PACKAGE

(TOP VIEW)

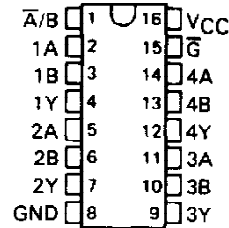

SN54HC257, SN54HC258 . . . FK PACKAGE

(TOP VIEW)

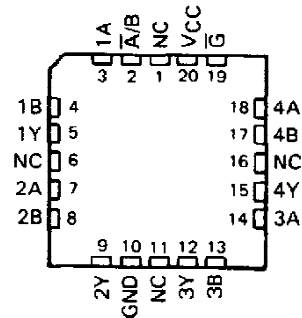

### description

These devices are designed to multiplex signals from four-bit data sources to four-output data lines in bus-organized systems. The 3-state outputs will not load the data lines when the output control pin ( $\bar{G}$ ) is at a high-logic level.

The SN54HC257 and SN54HC258 are characterized for operation over the full military temperature range of  $-55^{\circ}\text{C}$  to  $125^{\circ}\text{C}$ . The SN74HC257 and SN74HC258 are characterized for operation from  $-40^{\circ}\text{C}$  to  $85^{\circ}\text{C}$ .

FUNCTION TABLE

OUTPUT CONTROL $\bar{G}$	INPUTS			OUTPUT Y	
	SELECT $\bar{A}/B$	DATA		'HC257	'HC258
		A	B		
H	X	X	X	Z	Z
L	L	L	X	L	H
L	L	H	X	H	L
L	H	X	L	L	H
L	H	X	H	H	L

NC—No internal connection

<sup>†</sup>Contact the factory for D availability

PRODUCTION DATA documents contain information current as of publication date. Products conform to specifications per the terms of Texas Instruments standard warranty. Production processing does not necessarily include testing of all parameters.

Copyright © 1989, Texas Instruments Incorporated



POST OFFICE BOX 655012 • DALLAS, TEXAS 75265

**SN54HC257, SN54HC258, SN74HC257, SN74HC258**  
**QUAD 2-LINE TO 1-LINE DATA SELECTORS/MULTIPLEXERS**  
**WITH 3-STATE OUTPUTS**

logic symbols†

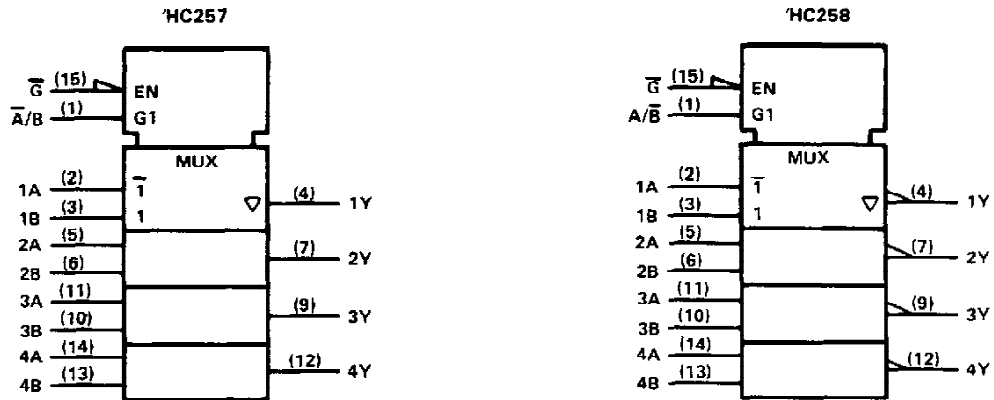

†These symbols are in accordance with ANSI/IEEE Std 91-1984 and IEC Publication 617-12.

logic diagrams (positive logic)

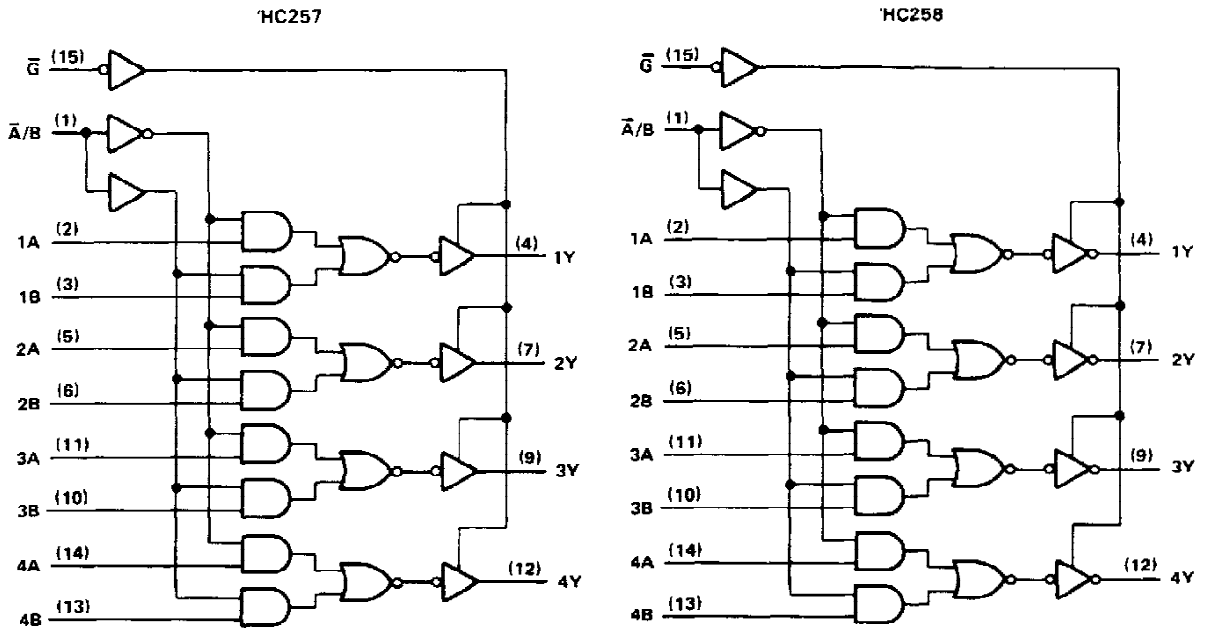

Pin numbers shown are for D, J, and N packages.

**SN54HC257, SN54HC258, SN74HC257, SN74HC258**  
**QUAD 2-LINE TO 1-LINE DATA SELECTORS/MULTIPLEXERS**  
**WITH 3-STATE OUTPUTS**

**absolute maximum ratings over operating free-air temperature range†**

Supply voltage, $V_{CC}$ .....	-0.5 V to 7 V
Input clamp current, $I_{IK}$ ( $V_I < 0$ or $V_I > V_{CC}$ ) .....	$\pm 20$ mA
Output clamp current, $I_{OK}$ ( $V_O < 0$ or $V_O > V_{CC}$ ) .....	$\pm 20$ mA
Continuous output current, $I_O$ ( $V_O = 0$ to $V_{CC}$ ) .....	$\pm 35$ mA
Continuous current through $V_{CC}$ or GND pins .....	$\pm 70$ mA
Lead temperature 1,6 mm (1/16 in) from case for 60 s: FK or J package .....	300°C
Lead temperature 1,6 mm (1/16 in) from case for 10 s: D or N package .....	260°C
Storage temperature range .....	-65°C to 150°C

† Stresses beyond those listed under "absolute maximum ratings" may cause permanent damage to the device. These are stress ratings only, and functional operation of the device at these or any other conditions beyond those indicated under "recommended operating conditions" is not implied. Exposure to absolute-maximum-rated conditions for extended periods may affect device reliability.

**recommended operating conditions**

		SN54HC257 SN54HC258			SN74HC257 SN74HC258			UNIT	
		MIN	NOM	MAX	MIN	NOM	MAX		
$V_{CC}$	Supply voltage	2	5	6	2	5	6	V	
$V_{IH}$	High-level input voltage	$V_{CC} = 2$ V $V_{CC} = 4.5$ V $V_{CC} = 6$ V		1.5 3.15 4.2	1.5 3.15 4.2			V	
$V_{IL}$	Low-level input voltage	$V_{CC} = 2$ V $V_{CC} = 4.5$ V $V_{CC} = 6$ V		0 0 0	0.3 0.9 1.2			V	
$V_I$	Input voltage			0	$V_{CC}$			V	
$V_O$	Output voltage			0	$V_{CC}$			V	
$t_t$	Input transition (rise and fall) times	$V_{CC} = 2$ V $V_{CC} = 4.5$ V $V_{CC} = 6$ V		0 0 0	1000 500 400			ns	
$T_A$	Operating free-air temperature			-55	125		-40	85	°C

**electrical characteristics over recommended operating free-air temperature range (unless otherwise noted)**

PARAMETER	TEST CONDITIONS	$V_{CC}$	$T_A = 25^\circ\text{C}$			SN54HC257 SN54HC258		SN74HC257 SN74HC258		UNIT
			MIN	TYP	MAX	MIN	MAX	MIN	MAX	
$V_{OH}$	$V_I = V_{IH}$ or $V_{IL}$ , $I_{OH} = -20 \mu\text{A}$	2 V	1.9	1.998		1.9		1.9	V	
		4.5 V	4.4	4.499		4.4		4.4		
		6 V	5.9	5.999		5.9		5.9		
	$V_I = V_{IH}$ or $V_{IL}$ , $I_{OH} = -6$ mA	4.5 V	3.98	4.30		3.7		3.84		
	$V_I = V_{IH}$ or $V_{IL}$ , $I_{OH} = -7.8$ mA	6 V	5.48	5.80		5.2		5.34		
$V_{OL}$	$V_I = V_{IH}$ or $V_{IL}$ , $I_{OL} = 20 \mu\text{A}$	2 V		0.002	0.1		0.1		0.1	V
		4.5 V		0.001	0.1		0.1		0.1	
		6 V		0.001	0.1		0.1		0.1	
	$V_I = V_{IH}$ or $V_{IL}$ , $I_{OL} = 6$ mA	4.5 V		0.17	0.26		0.4		0.33	
	$V_I = V_{IH}$ or $V_{IL}$ , $I_{OL} = 7.8$ mA	6 V		0.15	0.26		0.4		0.33	
$I_I$	$V_I = V_{CC}$ or 0	6 V		$\pm 0.1$	$\pm 100$		$\pm 1000$		$\pm 1000$	nA
$I_{OZ}$	$V_O = V_{CC}$ or 0, $V_I = V_{IH}$ or $V_{IL}$	6 V		$\pm 0.01$	$\pm 0.5$		$\pm 10$		$\pm 5$	$\mu\text{A}$
$I_{CC}$	$V_I = V_{CC}$ or 0, $I_O = 0$	6 V					8		160	$\mu\text{A}$
$C_i$		2 to 6 V		3	10		10		10	pF

**SN54HC257, SN74HC257**  
**QUAD 2-LINE TO 1-LINE DATA SELECTORS/MULTIPLEXERS**  
**WITH 3-STATE OUTPUTS**

switching characteristics over recommended operating free-air temperature range (unless otherwise noted),  $C_L = 50$  pF (see Note 1)

PARAMETER	FROM (INPUT)	TO (OUTPUT)	V <sub>CC</sub>	T <sub>A</sub> = 25°C			SN54HC257		SN74HC257		UNIT
				MIN	TYP	MAX	MIN	MAX	MIN	MAX	
t <sub>pd</sub>	A or B	Any Y	2 V		50	100		150		125	ns
			4.5 V		10	20		30		25	
			6 V		9	17		25		21	
t <sub>pd</sub>	$\bar{A}/B$	Any Y	2 V		50	100		150		125	ns
			4.5 V		10	20		30		25	
			6 V		9	17		25		21	
t <sub>en</sub>	$\bar{C}$	Any Y	2 V		75	150		225		190	ns
			4.5 V		15	30		45		38	
			6 V		13	26		38		32	
t <sub>dis</sub>	$\bar{C}$	Any Y	2 V		75	150		225		190	ns
			4.5 V		15	30		45		38	
			6 V		13	26		38		32	
t <sub>t</sub>		Any	2 V		28	60		90		75	ns
			4.5 V		8	12		18		15	
			6 V		6	10		15		13	

C <sub>pd</sub>	Power dissipation capacitance per multiplexer	No load, T <sub>A</sub> = 25°C	40 pF typ
-----------------	---	--------------------------------	-----------

switching characteristics over recommended operating free-air temperature range (unless otherwise noted),  $C_L = 150$  pF (see Note 1)

PARAMETER	FROM (INPUT)	TO (OUTPUT)	V <sub>CC</sub>	T <sub>A</sub> = 25°C			SN54HC257		SN74HC257		UNIT
				MIN	TYP	MAX	MIN	MAX	MIN	MAX	
t <sub>pd</sub>	A or B	Any Y	2 V		75	150		245		190	ns
			4.5 V		15	30		45		38	
			6 V		13	26		38		32	
t <sub>pd</sub>	$\bar{A}/B$	Any Y	2 V		75	150		245		190	ns
			4.5 V		15	30		45		38	
			6 V		13	26		38		32	
t <sub>en</sub>	$\bar{C}$	Any Y	2 V		100	200		300		250	ns
			4.5 V		24	40		60		50	
			6 V		18	34		51		43	
t <sub>t</sub>		Any	2 V		45	210		315		265	ns
			4.5 V		17	42		63		53	
			6 V		13	36		53		45	

NOTE 1: Load circuits and voltage waveforms are shown in Section 1.

**SN54HC258, SN74HC258**  
**QUAD 2-LINE TO 1-LINE DATA SELECTORS/MULTIPLEXERS**  
**WITH 3-STATE OUTPUTS**

switching characteristics over recommended operating free-air temperature range (unless otherwise noted),  $C_L = 50 \text{ pF}$  (see Note 1)

PARAMETER	FROM (INPUT)	TO (OUTPUT)	$V_{CC}$	$T_A = 25^\circ\text{C}$			SN54HC258		SN74HC258		UNIT
				MIN	TYP	MAX	MIN	MAX	MIN	MAX	
$t_{pd}$	A or B	Any Y	2 V		60	100		150		125	ns
			4.5 V		13	20		30		25	
			6 V		12	17		25		21	
$t_{pd}$	$\bar{A}/B$	Any Y	2 V		60	115		175		145	ns
			4.5 V		13	23		35		29	
			6 V		12	20		30		25	
$t_{en}$	$\bar{G}$	Any Y	2 V		70	150		225		190	ns
			4.5 V		15	30		45		38	
			6 V		13	26		38		32	
$t_{dis}$	$\bar{G}$	Any Y	2 V		75	150		225		190	ns
			4.5 V		15	30		45		38	
			6 V		13	26		38		32	
$t_t$		Any	2 V		28	60		90		75	ns
			4.5 V		8	12		18		15	
			6 V		6	10		15		13	

$C_{pd}$	Power dissipation capacitance per multiplexer	No load, $T_A = 25^\circ\text{C}$	40 pF typ
----------	---	-----------------------------------	-----------

switching characteristics over recommended operating free-air temperature range (unless otherwise noted),  $C_L = 150 \text{ pF}$  (see Note 1)

PARAMETER	FROM (INPUT)	TO (OUTPUT)	$V_{CC}$	$T_A = 25^\circ\text{C}$			SN54HC258		SN74HC258		UNIT
				MIN	TYP	MAX	MIN	MAX	MIN	MAX	
$t_{pd}$	A or B	Any Y	2 V		95	150		245		190	ns
			4.5 V		23	30		45		38	
			6 V		21	26		38		32	
$t_{pd}$	$\bar{A}/B$	Any Y	2 V		95	165		240		210	ns
			4.5 V		23	33		48		42	
			6 V		21	28		41		36	
$t_{en}$	$\bar{G}$	Any Y	2 V		100	200		300		250	ns
			4.5 V		24	40		60		50	
			6 V		18	34		51		43	
$t_t$		Any	2 V		45	210		315		265	ns
			4.5 V		17	42		63		53	
			6 V		13	36		53		45	

NOTE 1: Load circuits and voltage waveforms are shown in Section 1.

## IMPORTANT NOTICE

Texas Instruments (TI) reserves the right to make changes to its products or to discontinue any semiconductor product or service without notice, and advises its customers to obtain the latest version of relevant information to verify, before placing orders, that the information being relied on is current.

TI warrants performance of its semiconductor products and related software to the specifications applicable at the time of sale in accordance with TI's standard warranty. Testing and other quality control techniques are utilized to the extent TI deems necessary to support this warranty. Specific testing of all parameters of each device is not necessarily performed, except those mandated by government requirements.

Certain applications using semiconductor products may involve potential risks of death, personal injury, or severe property or environmental damage ("Critical Applications").

TI SEMICONDUCTOR PRODUCTS ARE NOT DESIGNED, INTENDED, AUTHORIZED, OR WARRANTED TO BE SUITABLE FOR USE IN LIFE-SUPPORT APPLICATIONS, DEVICES OR SYSTEMS OR OTHER CRITICAL APPLICATIONS.

Inclusion of TI products in such applications is understood to be fully at the risk of the customer. Use of TI products in such applications requires the written approval of an appropriate TI officer. Questions concerning potential risk applications should be directed to TI through a local SC sales office.

In order to minimize risks associated with the customer's applications, adequate design and operating safeguards should be provided by the customer to minimize inherent or procedural hazards.

TI assumes no liability for applications assistance, customer product design, software performance, or infringement of patents or services described herein. Nor does TI warrant or represent that any license, either express or implied, is granted under any patent right, copyright, mask work right, or other intellectual property right of TI covering or relating to any combination, machine, or process in which such semiconductor products or services might be or are used.

## **IMPORTANT NOTICE**

Texas Instruments and its subsidiaries (TI) reserve the right to make changes to their products or to discontinue any product or service without notice, and advise customers to obtain the latest version of relevant information to verify, before placing orders, that information being relied on is current and complete. All products are sold subject to the terms and conditions of sale supplied at the time of order acknowledgement, including those pertaining to warranty, patent infringement, and limitation of liability.

TI warrants performance of its semiconductor products to the specifications applicable at the time of sale in accordance with TI's standard warranty. Testing and other quality control techniques are utilized to the extent TI deems necessary to support this warranty. Specific testing of all parameters of each device is not necessarily performed, except those mandated by government requirements.

**CERTAIN APPLICATIONS USING SEMICONDUCTOR PRODUCTS MAY INVOLVE POTENTIAL RISKS OF DEATH, PERSONAL INJURY, OR SEVERE PROPERTY OR ENVIRONMENTAL DAMAGE ("CRITICAL APPLICATIONS"). TI SEMICONDUCTOR PRODUCTS ARE NOT DESIGNED, AUTHORIZED, OR WARRANTED TO BE SUITABLE FOR USE IN LIFE-SUPPORT DEVICES OR SYSTEMS OR OTHER CRITICAL APPLICATIONS. INCLUSION OF TI PRODUCTS IN SUCH APPLICATIONS IS UNDERSTOOD TO BE FULLY AT THE CUSTOMER'S RISK.**

In order to minimize risks associated with the customer's applications, adequate design and operating safeguards must be provided by the customer to minimize inherent or procedural hazards.

TI assumes no liability for applications assistance or customer product design. TI does not warrant or represent that any license, either express or implied, is granted under any patent right, copyright, mask work right, or other intellectual property right of TI covering or relating to any combination, machine, or process in which such semiconductor products or services might be or are used. TI's publication of information regarding any third party's products or services does not constitute TI's approval, warranty or endorsement thereof.

This datasheet has been downloaded from:

[www.DatasheetCatalog.com](http://www.DatasheetCatalog.com)

Datasheets for electronic components.