

2N5781 PNP
2N5784 NPN

**COMPLEMENTARY SILICON
POWER TRANSISTORS**



TO-39 CASE



www.centrasemi.com

DESCRIPTION:

The CENTRAL SEMICONDUCTOR 2N5781 and 2N5784 types are Complementary Silicon Power Transistors designed for general purpose switching and amplifier applications.

MARKING: FULL PART NUMBER

MAXIMUM RATINGS: ($T_C=25^\circ\text{C}$)

Collector-Base Voltage
Collector-Emitter Voltage
Collector-Emitter Voltage
Emitter-Base Voltage
Continuous Collector Current
Continuous Base Current
Power Dissipation
Power Dissipation ($T_A=25^\circ\text{C}$)
Operating and Storage Junction Temperature
Thermal Resistance
Thermal Resistance

SYMBOL

V_{CBO} 80
 V_{CER} 80
 V_{CEO} 65
 V_{EBO} 5.0
 I_C 3.5
 I_B 1.0
 P_D 10
 P_D 1.0
 T_J, T_{stg} -65 to +200
 θ_{JC} 17.5
 θ_{JA} 175

UNITS

V
V
V
V
A
A
W
W
 $^\circ\text{C}$
 $^\circ\text{C/W}$
 $^\circ\text{C/W}$

ELECTRICAL CHARACTERISTICS: ($T_C=25^\circ\text{C}$ unless otherwise noted)

SYMBOL	TEST CONDITIONS	MIN	MAX	UNITS
I_{CEV}	$V_{CE}=75\text{V}, V_{BE}=1.5\text{V}$		10	μA
I_{CEV}	$V_{CE}=75\text{V}, V_{BE}=1.5\text{V}, T_C=150^\circ\text{C}$		1.0	mA
I_{CER}	$V_{CE}=65\text{V}, R_{BE}=100\Omega$		10	μA
I_{CER}	$V_{CE}=65\text{V}, R_{BE}=100\Omega, T_C=150^\circ\text{C}$		1.0	mA
I_{CEO}	$V_{CE}=50\text{V}$		100	μA
I_{EBO}	$V_{EB}=5.0\text{V}$		10	μA
BV_{CER}	$I_C=10\text{mA}, R_{BE}=100\Omega$	80		V
BV_{CEO}	$I_C=10\text{mA}$	65		V
$V_{CE(SAT)}$	$I_C=1.0\text{A}, I_B=100\text{mA}$		0.5	V
$V_{BE(ON)}$	$V_{CE}=2.0\text{V}, I_C=1.0\text{A}$		1.5	V
h_{FE}	$V_{CE}=2.0\text{V}, I_C=1.0\text{A}$	20	150	
h_{FE}	$V_{CE}=2.0\text{V}, I_C=3.2\text{A}$	4.0		
f_T	$V_{CE}=2.0\text{V}, I_C=100\text{mA}, f=4.0\text{MHz}$ (2N5781)	8.0	60	MHz
f_T	$V_{CE}=2.0\text{V}, I_C=100\text{mA}, f=200\text{kHz}$ (2N5784)	1.0	4.0	MHz
h_{fe}	$V_{CE}=2.0\text{V}, I_C=100\text{mA}, f=1.0\text{kHz}$	25		
t_{on}	$V_{CC}=30\text{V}, I_C=1.0\text{A}, I_{B1}=I_{B2}=100\text{mA}$ (2N5781)		0.5	μs
t_{on}	$V_{CC}=30\text{V}, I_C=1.0\text{A}, I_{B1}=I_{B2}=100\text{mA}$ (2N5784)		5.0	μs
t_{off}	$V_{CC}=30\text{V}, I_C=1.0\text{A}, I_{B1}=I_{B2}=100\text{mA}$ (2N5781)		2.5	μs
t_{off}	$V_{CC}=30\text{V}, I_C=1.0\text{A}, I_{B1}=I_{B2}=100\text{mA}$ (2N5784)		15	μs

R1 (25-January 2011)

2N5781 PNP
2N5784 NPN

COMPLEMENTARY SILICON
POWER TRANSISTORS



TO-39 CASE - MECHANICAL OUTLINE

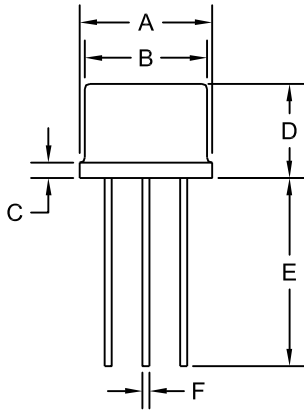

SYMBOL	INCHES		MILLIMETERS	
	MIN	MAX	MIN	MAX
A (DIA)	0.335	0.370	8.51	9.40
B (DIA)	0.315	0.335	8.00	8.51
C	-	0.040	-	1.02
D	0.240	0.260	6.10	6.60
E	0.500	-	12.70	-
F (DIA)	0.016	0.021	0.41	0.53
G (DIA)	0.200		5.08	
H	0.100		2.54	
I	0.028	0.034	0.71	0.86
J	0.029	0.045	0.74	1.14

TO-39 (REV: R1)

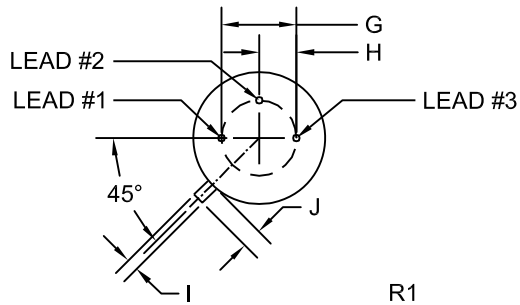

LEAD CODE:

- 1) Emitter
- 2) Base
- 3) Collector

MARKING: FULL PART NUMBER

R1 (25-January 2011)

OUTSTANDING SUPPORT AND SUPERIOR SERVICES



PRODUCT SUPPORT

Central's operations team provides the highest level of support to insure product is delivered on-time.

- Supply management (Customer portals)
- Inventory bonding
- Consolidated shipping options
- Custom bar coding for shipments
- Custom product packing

DESIGNER SUPPORT/SERVICES

Central's applications engineering team is ready to discuss your design challenges. Just ask.

- Free quick ship samples (2nd day air)
- Online technical data and parametric search
- SPICE models
- Custom electrical curves
- Environmental regulation compliance
- Customer specific screening
- Up-screening capabilities
- Special wafer diffusions
- PbSn plating options
- Package details
- Application notes
- Application and design sample kits
- Custom product and package development

CONTACT US

Corporate Headquarters & Customer Support Team

Central Semiconductor Corp.
145 Adams Avenue
Hauppauge, NY 11788 USA
Main Tel: (631) 435-1110
Main Fax: (631) 435-1824
Support Team Fax: (631) 435-3388
www.centalsemi.com

Worldwide Field Representatives:
www.centalsemi.com/wwreps

Worldwide Distributors:
www.centalsemi.com/wwdistributors

For the latest version of Central Semiconductor's **LIMITATIONS AND DAMAGES DISCLAIMER**, which is part of Central's Standard Terms and Conditions of sale, visit: www.centalsemi.com/terms