

# ***TMS320VC5409 Fixed-Point Digital Signal Processor***

## ***Data Manual***

Literature Number: SPRS082F  
April 1999 – Revised October 2008

PRODUCTION DATA information is current as of publication date. Products conform to specifications per the terms of Texas Instruments standard warranty. Production processing does not necessarily include testing of all parameters.





## REVISION HISTORY

This data sheet revision history highlights the technical changes made to the SPRS082E device-specific data sheet to make it an SPRS082F revision.

**Scope:** This document has been reviewed for technical accuracy; the technical content is up-to-date as of the specified release date with the following changes.

PAGE(S) NO.	ADDITIONS/CHANGES/DELETIONS
15	Moved "Terminal Functions" section (was Section 3.5 in SPRS082E) to Section 2.4
15	The "Terminal Functions" table (was Table 3–19 in SPRS082E) is now Table 2–2
15	Table 2–2, Terminal Functions: <ul style="list-style-type: none"> <li>– Updated DESCRIPTION of <u>TRST</u></li> <li>– Added footnote about <u>TRST</u></li> </ul>
87	Section 6, Mechanical Data: <ul style="list-style-type: none"> <li>– Added Section 6.1, Package Thermal Resistance Characteristics</li> <li>– Table 6–1, Thermal Resistance Characteristics: <ul style="list-style-type: none"> <li>– Updated <math>R_{\theta JA}</math> and <math>R_{\theta JC}</math> values for GGU package</li> <li>– Updated <math>R_{\theta JA}</math> and <math>R_{\theta JC}</math> values for PGE package</li> </ul> </li> <li>– Added Section 6.2, Packaging Information</li> <li>– Mechanical drawings will be appended to this document via an automated process</li> </ul>



# Contents

<i>Section</i>	<i>Page</i>
<b>1 TMS320VC5409 Features</b> .....	<b>11</b>
<b>2 Introduction</b> .....	<b>12</b>
2.1 Pin Assignments .....	12
2.2 GGU Package Layout and Pin Assignments .....	12
2.3 PGE Package Layout and Pin Assignments .....	14
2.4 Terminal Functions .....	15
<b>3 Functional Overview</b> .....	<b>21</b>
3.1 CPU Core .....	21
3.1.1 Software Programmable Wait-State Generator .....	21
3.1.2 Programmable Bank-Switching Wait States .....	23
3.1.3 CPU Memory-Mapped Registers .....	25
3.2 Memory .....	26
3.2.1 Memory Map .....	26
3.2.2 On-Chip ROM With Bootloader .....	27
3.2.3 On-Chip RAM .....	27
3.2.4 On-Chip Memory Security .....	27
3.2.5 Relocatable Interrupt Vector Table .....	28
3.2.6 Extended Program Memory .....	28
3.3 On-Chip Peripherals .....	29
3.3.1 Parallel I/O Ports .....	29
3.3.2 Multichannel Buffered Serial Ports (McBSPs) .....	32
3.3.3 Hardware Timer .....	36
3.3.4 Clock Generator .....	36
3.3.5 DMA Controller .....	38
3.3.6 Peripheral Memory-Mapped Registers .....	45
3.4 Interrupts .....	46
<b>4 Documentation Support</b> .....	<b>48</b>
4.1 Device and Development Tool Support Nomenclature .....	49
<b>5 Electrical Specifications</b> .....	<b>50</b>
5.1 Absolute Maximum Ratings .....	50
5.2 Recommended Operating Conditions .....	50
5.3 Electrical Characteristics .....	51
5.4 Internal Oscillator with External Crystal .....	52
5.5 Divide-By-Two/Divide-By-Four Clock Option (PLL Disabled) .....	53
5.6 Multiply-By-N Clock Option (PLL Enabled) .....	54
5.7 Memory and Parallel I/O Interface Timing .....	55
5.7.1 Memory Read .....	55
5.7.2 Memory Write .....	57
5.7.3 Parallel I/O Port Read .....	59
5.7.4 Parallel I/O Port Write .....	60

Section	Page
5.8 Ready Timing for Externally Generated Wait States .....	61
5.9 $\overline{\text{HOLD}}$ and $\overline{\text{HOLDA}}$ Timings .....	65
5.10 Reset, $\overline{\text{BIO}}$ , Interrupt, and $\overline{\text{MP/MC}}$ Timings .....	66
5.11 Instruction Acquisition ( $\overline{\text{IAQ}}$ ) and Interrupt Acknowledge ( $\overline{\text{IACK}}$ ) Timings .....	68
5.12 External Flag (XF) and TOUT Timings .....	69
5.13 Multichannel Buffered Serial Port (McBSP) Timing .....	70
5.13.1 McBSP Transmit and Receive Timings .....	70
5.13.2 McBSP General-Purpose I/O Timing .....	73
5.13.3 McBSP as SPI Master or Slave Timing .....	74
5.14 Host-Port Interface Timing .....	78
5.14.1 HPI8 Mode .....	78
5.14.2 HPI16 Mode .....	82
5.15 GPIO Timing Requirements .....	86
<b>6 Mechanical Data .....</b>	<b>87</b>
6.1 Package Thermal Resistance Characteristics .....	87
6.2 Packaging Information .....	87

## List of Figures

<i>Figure</i>		<i>Page</i>
2-1	GGU Package (Bottom View) .....	12
2-2	PGE Package (Top View) .....	14
3-1	TMS320VC5409 Functional Block Diagram .....	21
3-2	Software Wait-State Register (SWWSR) [Memory-Mapped Register (MMR) Address 0028h] ...	22
3-3	Software Wait-State Configuration Register (SWCR) [MMR Address 002Bh] .....	23
3-4	Bank-Switching Control Register (BSCR) [MMR Address 0029h] .....	23
3-5	Memory Map .....	26
3-6	Extended Program Memory .....	29
3-7	5409 HPI Memory Map .....	30
3-8	Pin Control Register (PCR) .....	32
3-9	Sample Rate Generator Register 2 (SRGR2) .....	35
3-10	TMS320VC5409 DMA Memory Map .....	40
3-11	IFR and IMR Registers .....	47
5-1	3.3-V Test Load Circuit .....	51
5-2	Internal Oscillator With External Crystal .....	52
5-3	External Divide-by-Two Clock Timing .....	53
5-4	External Multiply-by-One Clock Timing .....	54
5-5	Memory Read .....	56
5-6	Memory Write .....	58
5-7	Parallel I/O Port Read .....	59
5-8	Parallel I/O Port Write .....	60
5-9	Memory Read With Externally Generated Wait States .....	61
5-10	Memory Write With Externally Generated Wait States .....	62
5-11	I/O Read With Externally Generated Wait States .....	63
5-12	I/O Write With Externally Generated Wait States .....	64
5-13	$\overline{\text{HOLD}}$ and $\overline{\text{HOLDA}}$ Timings .....	65
5-14	Reset and $\overline{\text{BIO}}$ Timings .....	67
5-15	Interrupt Timing .....	67
5-16	$\overline{\text{MP}}/\overline{\text{MC}}$ Timing .....	67
5-17	$\overline{\text{IAQ}}$ and $\overline{\text{IACK}}$ Timings .....	68
5-18	XF Timing .....	69
5-19	TOUT Timing .....	69
5-20	McBSP Receive Timings .....	72
5-21	McBSP Transmit Timings .....	72
5-22	McBSP General-Purpose I/O Timings .....	73
5-23	McBSP Timing as SPI Master or Slave: CLKSTP = 10b, CLKXP = 0 .....	74
5-24	McBSP Timing as SPI Master or Slave: CLKSTP = 11b, CLKXP = 0 .....	75

Figure	Page
5-25 McBSP Timing as SPI Master or Slave: CLKSTP = 10b, CLKXP = 1 .....	76
5-26 McBSP Timing as SPI Master or Slave: CLKSTP = 11b, CLKXP = 1 .....	77
5-27 Using $\overline{\text{HDS}}$ to Control Accesses ( $\overline{\text{HCS}}$ Always Low) .....	80
5-28 Using $\overline{\text{HCS}}$ to Control Accesses .....	81
5-29 HRDY Relative to CLKOUT .....	81
5-30 $\overline{\text{HINT}}$ Timing .....	81
5-31 Nonmultiplexed Read Timings .....	84
5-32 Nonmultiplexed Write Timings .....	85
5-33 GPIOx Timings .....	86



## List of Tables

<i>Table</i>		<i>Page</i>
2-1	Pin Assignments for the GGU (144-Pin BGA Package) .....	13
2-2	Terminal Functions .....	15
3-1	Software Wait-State Register (SWWSR) Bit Fields .....	22
3-2	Software Wait-State Configuration Register (SWCR) Bit Fields .....	23
3-3	Bank-Switching Control Register Fields .....	24
3-4	CPU Memory-Mapped Registers .....	25
3-5	Standard On-Chip ROM Layout .....	27
3-6	Bus Holder Control Bits .....	31
3-7	Pin Control Register (PCR) Bit Field Description .....	33
3-8	Sample Rate Generator Clock Input Options .....	35
3-9	Sample Rate Generator Register 2 (SRGR2) Bit Field Descriptions .....	35
3-10	McBSP Control Registers and Subaddresses .....	36
3-11	Clock Mode Settings at Reset .....	37
3-12	DMA Interrupts .....	42
3-13	DMA Synchronization Events .....	42
3-14	DMA Channel Interrupt Selection .....	43
3-15	DMA Subbank Addressed Registers .....	43
3-16	Peripheral Memory-Mapped Registers .....	45
3-17	Interrupt Locations and Priorities .....	46
3-18	IFR and IMR Register Bit Fields .....	47
5-1	Recommended Operating Conditions of Internal Oscillator With External Crystal .....	52
5-2	Divide-By-Two/Divide-By-Four Clock Option (PLL Disabled) Timing Requirements .....	53
5-3	Divide-By-Two/Divide-By-Four Clock Option (PLL Disabled) Switching Characteristics .....	53
5-4	Multiply-By-N Clock Option (PLL Enabled) Timing Requirements .....	54
5-5	Multiply-By-N Clock Option (PLL Enabled) Switching Characteristics .....	54
5-6	Memory Read Timing Requirements .....	55
5-7	Memory Read Switching Characteristics .....	55
5-8	Memory Write Switching Characteristics .....	57
5-9	Parallel I/O Read Port Timing Requirements .....	59
5-10	Parallel I/O Port Read Switching Characteristics .....	59
5-11	Parallel I/O Port Write Switching Characteristics .....	60
5-12	Ready Timing Requirements for Externally Generated Wait States .....	61
5-13	Ready Switching Characteristics for Externally Generated Wait States .....	61
5-14	HOLD and $\overline{\text{HOLDA}}$ Timing Requirements .....	65
5-15	HOLD and $\overline{\text{HOLDA}}$ Switching Characteristics .....	65
5-16	Reset, $\overline{\text{BIO}}$ , Interrupt, and $\overline{\text{MP/MC}}$ Timing Requirements .....	66
5-17	Instruction Acquisition ( $\overline{\text{IAQ}}$ ) and Interrupt Acknowledge ( $\overline{\text{IACK}}$ ) Switching Characteristics .....	68
5-18	External Flag (XF) and TOUT Switching Characteristics .....	69
5-19	McBSP Transmit and Receive Timing Requirements .....	70
5-20	McBSP Transmit and Receive Switching Characteristics .....	71
5-21	McBSP General-Purpose I/O Timing Requirements .....	73
5-22	McBSP General-Purpose I/O Switching Characteristics .....	73

<i>Table</i>	<i>Page</i>
5–23 McBSP as SPI Master or Slave Timing Requirements (CLKSTP = 10b, CLKXP = 0) . . . . .	74
5–24 McBSP as SPI Master or Slave Switching Characteristics (CLKSTP = 10b, CLKXP = 0) . . . . .	74
5–25 McBSP as SPI Master or Slave Timing Requirements (CLKSTP = 11b, CLKXP = 0) . . . . .	75
5–26 McBSP as SPI Master or Slave Switching Characteristics (CLKSTP = 11b, CLKXP = 0) . . . . .	75
5–27 McBSP as SPI Master or Slave Timing Requirements (CLKSTP = 10b, CLKXP = 1) . . . . .	76
5–28 McBSP as SPI Master or Slave Switching Characteristics (CLKSTP = 10b, CLKXP = 1) . . . . .	76
5–29 McBSP as SPI Master or Slave Timing Requirements (CLKSTP = 11b, CLKXP = 1) . . . . .	77
5–30 McBSP as SPI Master or Slave Switching Characteristics (CLKSTP = 11b, CLKXP = 1) . . . . .	77
5–31 HPI8 Mode Timing Requirements . . . . .	78
5–32 HPI8 Mode Switching Characteristics . . . . .	79
5–33 HPI16 Mode Timing Requirements . . . . .	82
5–34 HPI16 Mode Switching Characteristics . . . . .	83
5–35 GPIO Timing Requirements . . . . .	86
5–36 GPIO Switching Characteristics . . . . .	86
6–1 Thermal Resistance Characteristics . . . . .	87

## 1 TMS320VC5409 Features

- **Advanced Multibus Architecture With Three Separate 16-Bit Data Memory Buses and One Program Memory Bus**
- **40-Bit Arithmetic Logic Unit (ALU), Including a 40-Bit Barrel Shifter and Two Independent 40-Bit Accumulators**
- **17- × 17-Bit Parallel Multiplier Coupled to a 40-Bit Dedicated Adder for Non-Pipelined Single-Cycle Multiply/Accumulate (MAC) Operation**
- **Compare, Select, and Store Unit (CSSU) for the Add/Compare Selection of the Viterbi Operator**
- **Exponent Encoder to Compute an Exponent Value of a 40-Bit Accumulator Value in a Single Cycle**
- **Two Address Generators With Eight Auxiliary Registers and Two Auxiliary Register Arithmetic Units (ARAUs)**
- **Data Bus With a Bus-Holder Feature**
- **Extended Addressing Mode for 8M × 16-Bit Maximum Addressable External Program Space**
- **16K x 16-Bit On-Chip ROM**
- **32K x 16-Bit Dual-Access On-Chip RAM**
- **Single-Instruction-Repeat and Block-Repeat Operations for Program Code**
- **Block-Memory-Move Instructions for Better Program and Data Management**
- **Instructions With a 32-Bit Long Word Operand**
- **Instructions With Two- or Three-Operand Reads**
- **Arithmetic Instructions With Parallel Store and Parallel Load**
- **Conditional Store Instructions**
- **Fast Return From Interrupt**
- **On-Chip Peripherals**
  - **Software-Programmable Wait-State Generator and Programmable Bank Switching**
  - **On-Chip Phase-Locked Loop (PLL) Clock Generator With Internal Oscillator or External Clock Source**
  - **Three Multichannel Buffered Serial Ports (McBSPs)**
  - **Enhanced 8-Bit Parallel Host-Port Interface With 16-Bit Data/Addressing**
  - **One 16-Bit Timer**
  - **Six-Channel Direct Memory Access (DMA) Controller**
- **Power Consumption Control With IDLE1, IDLE2, and IDLE3 Instructions With Power-Down Modes**
- **CLKOUT Off Control to Disable CLKOUT**
- **On-Chip Scan-Based Emulation Logic, IEEE Std 1149.1<sup>†</sup> (JTAG) Boundary Scan Logic**
- **12.5-ns Single-Cycle Fixed-Point Instruction Execution Time (80 MIPS) for 3.3-V Power Supply (1.8-V Core)**
- **10-ns Single-Cycle Fixed-Point Instruction Execution Time (100 MIPS) for 3.3-V Power Supply (1.8-V Core)**
- **Available in a 144-Pin Plastic Thin Quad Flatpack (TQFP) (PGE Suffix) and a 144-Pin Ball Grid Array (BGA) (GGU Suffix)**



This integrated circuit can be damaged by ESD. Texas Instruments recommends that all integrated circuits be handled with appropriate precautions. Failure to observe proper handling and installation procedures can cause damage.

ESD damage can range from subtle performance degradation to complete device failure. Precision integrated circuits may be more susceptible to damage because very small parametric changes could cause the device not to meet its published specifications.

All trademarks are the property of their respective owners.

<sup>†</sup> IEEE Standard 1149.1-1990 Standard-Test-Access Port and Boundary Scan Architecture.

## 2 Introduction

The TMS320VC5409 fixed-point, digital signal processor (DSP) (hereafter referred to as the 5409 unless otherwise specified) is based on an advanced modified Harvard architecture that has one program memory bus and three data memory buses. This processor provides an arithmetic logic unit (ALU) with a high degree of parallelism, application-specific hardware logic, on-chip memory, and additional on-chip peripherals. The basis of the operational flexibility and speed of this DSP is a highly specialized instruction set.

Separate program and data spaces allow simultaneous access to program instructions and data, providing the high degree of parallelism. Two read operations and one write operation can be performed in a single cycle. Instructions with parallel store and application-specific instructions can fully utilize this architecture. In addition, data can be transferred between data and program spaces. Such parallelism supports a powerful set of arithmetic, logic, and bit-manipulation operations that can all be performed in a single machine cycle. In addition, the 5409 includes the control mechanisms to manage interrupts, repeated operations, and function calls.

**NOTE:** This data manual is designed to be used in conjunction with the *TMS320C54x™ DSP Functional Overview* (literature number SPRU307).

### 2.1 Pin Assignments

Figure 2–1 illustrates the ball number and location for the 144-pin GGU ball grid array. The pin assignments in Table 2–1 lists each signal quadrant and BGA ball number for the TMS320VC5409GGU (144-pin BGA package) which is footprint-compatible with the LC548, LC/VC549, and VC5410 devices. The DV<sub>DD</sub> pins in are the power supply for the I/O pins while CV<sub>DD</sub> is the power supply for the core CPU. V<sub>SS</sub> is the ground for both the I/O pins and the core CPU.

Figure 2–2 illustrates the pin number, location, and signal name for the 144-pin PGE package type.

### 2.2 GGU Package Layout and Pin Assignments

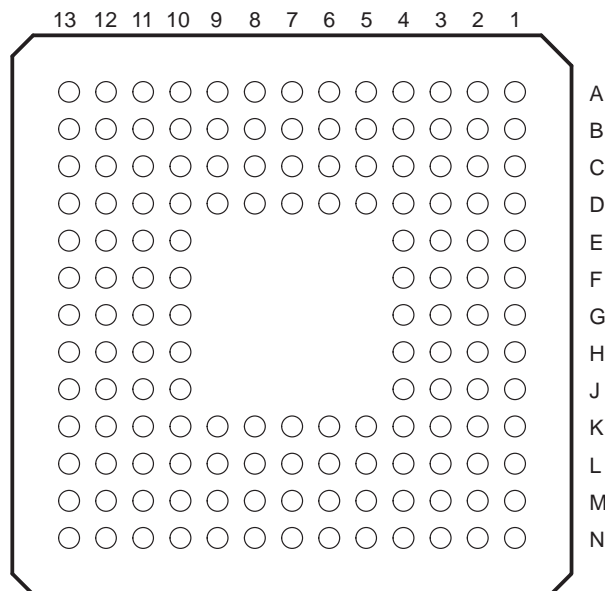


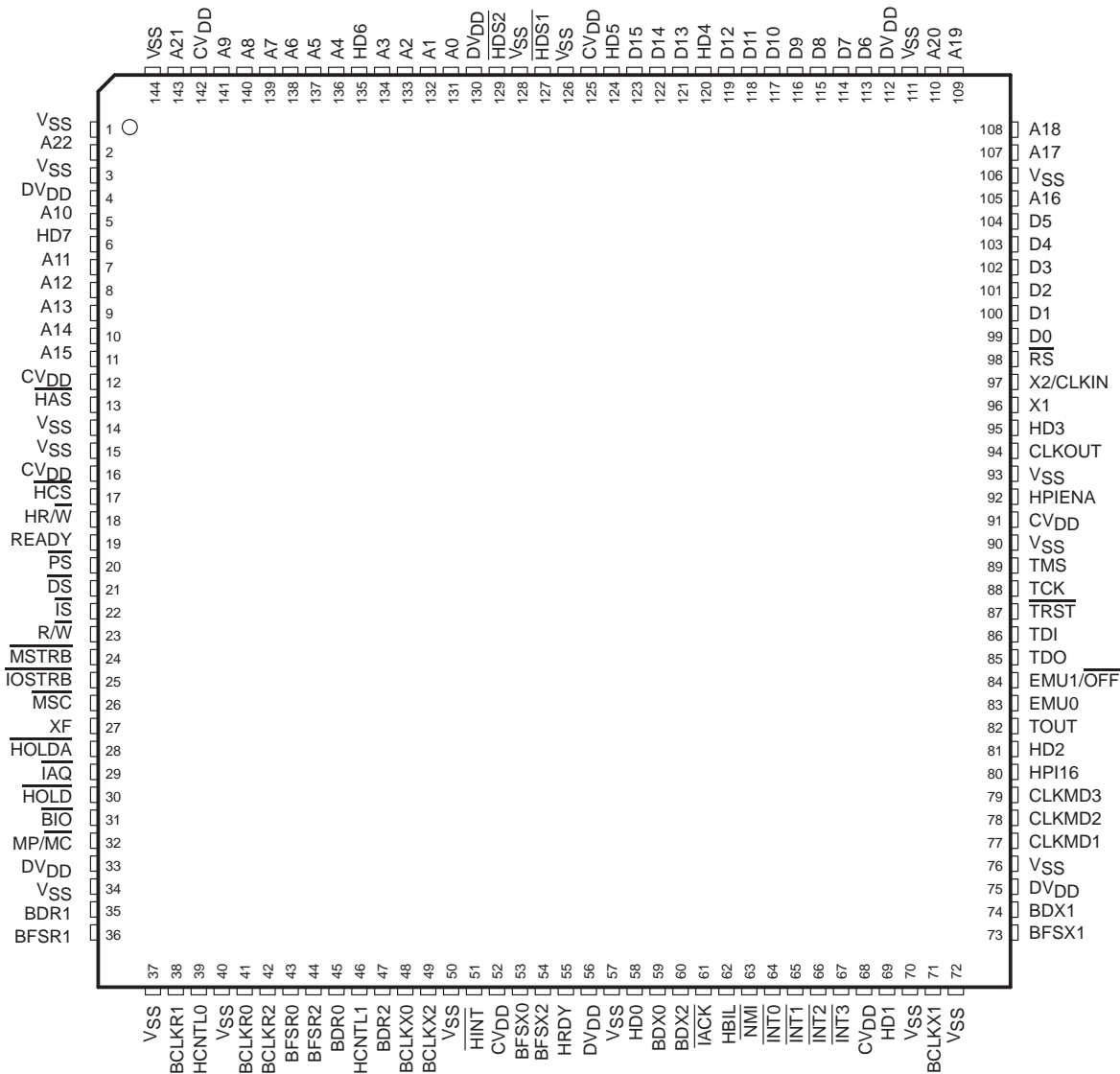
Figure 2–1. GGU Package (Bottom View)

Table 2–1. Pin Assignments for the GGU (144-Pin BGA Package)<sup>†</sup>

SIGNAL QUADRANT 1	BGA BALL #	SIGNAL QUADRANT 2	BGA BALL #	SIGNAL QUADRANT 3	BGA BALL #	SIGNAL QUADRANT 4	BGA BALL #
V <sub>SS</sub>	A1	BFSX1	N13	V <sub>SS</sub>	N1	A19	A13
A22	B1	BDX1	M13	BCLKR1	N2	A20	A12
V <sub>SS</sub>	C2	DVDD	L12	HCNTL0	M3	V <sub>SS</sub>	B11
DVDD	C1	V <sub>SS</sub>	L13	V <sub>SS</sub>	N3	DVDD	A11
A10	D4	CLKMD1	K10	BCLKR0	K4	D6	D10
HD7	D3	CLKMD2	K11	BCLKR2	L4	D7	C10
A11	D2	CLKMD3	K12	BFSR0	M4	D8	B10
A12	D1	HPI16	K13	BFSR2	N4	D9	A10
A13	E4	HD2	J10	BDR0	K5	D10	D9
A14	E3	TOUT	J11	HCNTL1	L5	D11	C9
A15	E2	EMU0	J12	BDR2	M5	D12	B9
CVDD	E1	EMU1/OFF	J13	BCLKX0	N5	HD4	A9
HAS	F4	TDO	H10	BCLKX2	K6	D13	D8
V <sub>SS</sub>	F3	TDI	H11	V <sub>SS</sub>	L6	D14	C8
V <sub>SS</sub>	F2	TRST	H12	HINT	M6	D15	B8
CVDD	F1	TCK	H13	CVDD	N6	HD5	A8
HCS	G2	TMS	G12	BFSX0	M7	CVDD	B7
HR/W	G1	V <sub>SS</sub>	G13	BFSX2	N7	V <sub>SS</sub>	A7
READY	G3	CVDD	G11	HRDY	L7	HDS1	C7
PS	G4	HPIENA	G10	DVDD	K7	V <sub>SS</sub>	D7
DS	H1	V <sub>SS</sub>	F13	V <sub>SS</sub>	N8	HDS2	A6
IS	H2	CLKOUT	F12	HD0	M8	DVDD	B6
R/W	H3	HD3	F11	BDX0	L8	A0	C6
MSTRB	H4	X1	F10	BDX2	K8	A1	D6
IOSTRB	J1	X2/CLKIN	E13	IACK	N9	A2	A5
MSC	J2	RS	E12	HBIL	M9	A3	B5
XF	J3	D0	E11	NMI	L9	HD6	C5
HOLDA	J4	D1	E10	INT0	K9	A4	D5
IAQ	K1	D2	D13	INT1	N10	A5	A4
HOLD	K2	D3	D12	INT2	M10	A6	B4
BIO	K3	D4	D11	INT3	L10	A7	C4
MP/MC	L1	D5	C13	CVDD	N11	A8	A3
DVDD	L2	A16	C12	HD1	M11	A9	B3
V <sub>SS</sub>	L3	V <sub>SS</sub>	C11	V <sub>SS</sub>	L11	CVDD	C3
BDR1	M1	A17	B13	BCLKX1	N12	A21	A2
BFSR1	M2	A18	B12	V <sub>SS</sub>	M12	V <sub>SS</sub>	B2

<sup>†</sup> DVDD is the power supply for the I/O pins while CVDD is the power supply for the core CPU. V<sub>SS</sub> is the ground for both the I/O pins and the core CPU.

### 2.3 PGE Package Layout and Pin Assignments



NOTE: DV<sub>DD</sub> is the power supply for the I/O pins while CV<sub>DD</sub> is the power supply for the core CPU. V<sub>SS</sub> is the ground for both the I/O pins and the core CPU.

The TMS320VC5409PGE (144-pin TQFP) package is footprint-compatible with the LC548, LC/VC549, and VC5410 devices.

Figure 2–2. PGE Package (Top View)

## 2.4 Terminal Functions

The 5409 Terminal Functions table lists each pin name, function, and operating mode(s) for the 5409 device. Some of the 5409 pins can be configured for one of two functions; a primary function and a secondary function. The names of these pins in secondary mode are shaded in grey in Table 2–2.

**Table 2–2. Terminal Functions**

TERMINAL NAME	INTERNAL PIN STATE	I/O†	DESCRIPTION
<b>DATA SIGNALS</b>			
A22 (MSB) A21 A20 A19 A18 A17 A16 A15 A14 A13 A12 A11 A10 A9 A8 A7 A6 A5 A4 A3 A2 A1 A0 (LSB)	Bus holders available (A15–A0)	O/Z	Parallel address bus A22 [most significant bit (MSB)] through A0 [least significant bit (LSB)]. The lower sixteen address pins (A15 to A0) are multiplexed to address all external memory (program, data) or I/O while the upper seven address pins (A22 to A16) are only used to address external program <u>space</u> . These pins are placed in the high-impedance state when the hold mode is enabled, or when $\overline{\text{OFF}}$ is low.
D15 (MSB) D14 D13 D12 D11 D10 D9 D8 D7 D6 D5 D4 D3 D2 D1 D0 (LSB)	Bus holders available	I/O/Z	Parallel data bus D15 (MSB) through D0 (LSB). The sixteen data pins (D15 to D0) are multiplexed to transfer data between the core CPU and external data/program memory or I/O devices. The data bus is placed in the high-impedance state when not outputting or when $\overline{\text{RS}}$ or $\overline{\text{HOLD}}$ is asserted. The data bus also goes into the high-impedance state when $\overline{\text{OFF}}$ is low.  The data bus has bus holders to reduce the static power dissipation caused by floating, unused pins. These bus holders also eliminate the need for external bias resistors on unused pins. When the data bus is not being driven by the 5409, the bus holders keep the pins at the previous logic level. The data bus holders on the 5409 are disabled at reset and can be enabled/disabled via the BH bit of the bank-switching control register (BSCR).

† I = Input, O = Output, Z = High-impedance, S = Supply

‡ Although this pin includes an internal pulldown resistor, a 470- $\Omega$  external pulldown is required. If the  $\overline{\text{TRST}}$  pin is connected to multiple DSPs, a buffer is recommended to ensure the  $V_{IL}$  and  $V_{IH}$  specifications are met.

Table 2–2. Terminal Functions (Continued)

TERMINAL NAME	INTERNAL PIN STATE	I/O†	DESCRIPTION
<b>INITIALIZATION, INTERRUPT, AND RESET OPERATIONS</b>			
$\overline{\text{IACK}}$		O/Z	Interrupt acknowledge signal. $\overline{\text{IACK}}$ indicates receipt of an interrupt and that the program counter is fetching the interrupt vector location designated by A15–A0. $\overline{\text{IACK}}$ also goes into the high-impedance state when $\overline{\text{OFF}}$ is low.
$\overline{\text{INT0}}$ $\overline{\text{INT1}}$ $\overline{\text{INT2}}$ $\overline{\text{INT3}}$	Schmitt trigger	I	External user interrupts. $\overline{\text{INT0}}$ – $\overline{\text{INT3}}$ are prioritized and are maskable by the interrupt mask register and the interrupt mode bit. $\overline{\text{INT0}}$ – $\overline{\text{INT3}}$ can be polled and reset by way of the interrupt flag register.
$\overline{\text{NMI}}$	Schmitt trigger	I	Nonmaskable interrupt. $\overline{\text{NMI}}$ is an external interrupt that cannot be masked by way of the INTM or the IMR. When $\overline{\text{NMI}}$ is activated, the processor traps to the appropriate vector location.
$\overline{\text{RS}}$	Schmitt trigger	I	Reset. $\overline{\text{RS}}$ causes the DSP to terminate execution and causes a reinitialization of the CPU and peripherals. When $\overline{\text{RS}}$ is brought to a high level, execution begins at location 0FF80h of program memory. $\overline{\text{RS}}$ affects various registers and status bits.
$\text{MP}/\overline{\text{MC}}$		I	Microprocessor/microcomputer mode select. If active low at reset, microcomputer mode is selected, and the internal program ROM is mapped into the upper program memory space. If the pin is driven high during reset, microprocessor mode is selected, and the on-chip ROM is removed from program space. $\text{MP}/\overline{\text{MC}}$ is only sampled at reset, and the $\text{MP}/\overline{\text{MC}}$ bit of the PMST register can override the mode that is selected at reset.
<b>MULTIPROCESSING SIGNALS</b>			
$\overline{\text{BIO}}$	Schmitt trigger	I	Branch control. A branch can be conditionally executed when $\overline{\text{BIO}}$ is active. If low, the processor executes the conditional instruction. For the XC instruction, the $\overline{\text{BIO}}$ condition is sampled during the decode phase of the pipeline; all other instructions sample $\overline{\text{BIO}}$ during the read phase of the pipeline.
XF		O/Z	External flag output (latched software-programmable signal). XF is set high by the SSBX XF instruction, set low by the RSBX XF instruction or by loading ST1. XF is used for signaling other processors in multiprocessor configurations or used as a general-purpose output pin. XF goes into the high-impedance state when $\overline{\text{OFF}}$ is low, and is set high at reset.
<b>MEMORY CONTROL SIGNALS</b>			
$\overline{\text{DS}}$ $\overline{\text{PS}}$ $\overline{\text{IS}}$		O/Z	Data, program, and I/O space select signals. $\overline{\text{DS}}$ , $\overline{\text{PS}}$ , and $\overline{\text{IS}}$ are always high unless driven low for accessing a particular external memory space. Active period corresponds to valid address information. $\overline{\text{DS}}$ , $\overline{\text{PS}}$ , and $\overline{\text{IS}}$ are placed into the high-impedance state in the hold mode; the signals also go into the high-impedance state when $\overline{\text{OFF}}$ is low.
$\overline{\text{MSTRB}}$		O/Z	Memory strobe signal. $\overline{\text{MSTRB}}$ is always high unless low-level asserted to indicate an external bus access to data or program memory. $\overline{\text{MSTRB}}$ is placed in the high-impedance state in the hold mode; it also goes into the high-impedance state when $\overline{\text{OFF}}$ is low.
READY		I	Data ready. READY indicates that an external device is prepared for a bus transaction to be completed. If the device is not ready (READY is low), the processor waits one cycle and checks READY again. Note that the processor performs ready detection if at least two software wait states are programmed. The READY signal is not sampled until the completion of the software wait states.
$\overline{\text{R}/\overline{\text{W}}}$		O/Z	Read/write signal. $\overline{\text{R}/\overline{\text{W}}}$ indicates transfer direction during communication to an external device. $\overline{\text{R}/\overline{\text{W}}}$ is normally in the read mode (high), unless it is asserted low when the DSP performs a write operation. $\overline{\text{R}/\overline{\text{W}}}$ is placed in the high-impedance state in hold mode; it also goes into the high-impedance state when $\overline{\text{OFF}}$ is low.
$\overline{\text{IOSTRB}}$		O/Z	I/O strobe signal. $\overline{\text{IOSTRB}}$ is always high unless low-level asserted to indicate an external bus access to an I/O device. $\overline{\text{IOSTRB}}$ is placed in the high-impedance state in the hold mode; it also goes into the high-impedance state when $\overline{\text{OFF}}$ is low.
$\overline{\text{HOLD}}$		I	Hold. $\overline{\text{HOLD}}$ is asserted to request control of the address, data, and control lines. When acknowledged by the C54x, these lines go into the high-impedance state.

† I = Input, O = Output, Z = High-impedance, S = Supply

‡ Although this pin includes an internal pulldown resistor, a 470- $\Omega$  external pulldown is required. If the  $\overline{\text{TRST}}$  pin is connected to multiple DSPs, a buffer is recommended to ensure the  $V_{IL}$  and  $V_{IH}$  specifications are met.



Table 2–2. Terminal Functions (Continued)

TERMINAL NAME	INTERNAL PIN STATE	I/O†	DESCRIPTION
<b>MEMORY CONTROL SIGNALS (CONTINUED)</b>			
$\overline{\text{HOLDA}}$		O/Z	Hold acknowledge. $\overline{\text{HOLDA}}$ indicates that the 5409 is in a hold state and that the address, data, and control lines are in the high-impedance state, allowing the external memory interface to be accessed by other devices. $\overline{\text{HOLDA}}$ also goes into the high-impedance state when $\overline{\text{OFF}}$ is low. This pin is driven high during reset.
$\overline{\text{MSC}}$		O/Z	Microstate complete. $\overline{\text{MSC}}$ indicates completion of all software wait states. When two or more software wait states are enabled, the $\overline{\text{MSC}}$ pin goes low during the last of these wait states. If connected to the $\overline{\text{READY}}$ input, $\overline{\text{MSC}}$ forces one external wait state after the last internal wait state is completed. $\overline{\text{MSC}}$ also goes into the high-impedance state when $\overline{\text{OFF}}$ is low.
$\overline{\text{IAQ}}$		O/Z	Instruction acquisition signal. $\overline{\text{IAQ}}$ is asserted (active low) when there is an instruction address on the address bus. $\overline{\text{IAQ}}$ goes into the high-impedance state when $\overline{\text{OFF}}$ is low.
<b>OSCILLATOR/TIMER SIGNALS</b>			
CLKOUT		O/Z	Master clock output signal. CLKOUT cycles at the machine-cycle rate of the CPU. The internal machine cycle is bounded by rising edges of this signal. CLKOUT also goes into the high-impedance state when $\overline{\text{OFF}}$ is low.
CLKMD1 CLKMD2 CLKMD3	Schmitt trigger	I	Clock mode select signals. These inputs select the mode that the clock generator is initialized to after reset. The logic levels of CLKMD1–CLKMD3 are latched when the reset pin is low, and the clock mode register is initialized to the selected mode. After reset, the clock mode can be changed through software, but the clock mode select signals have no effect until the device is reset again.
X2/CLKIN	Schmitt trigger	I	Clock/oscillator input. If the internal oscillator is not being used, X2/CLKIN functions as the clock input.
X1		O	Output pin from the internal oscillator for the crystal. If the internal oscillator is not used, X1 should be left unconnected. X1 does not go into the high-impedance state when $\overline{\text{OFF}}$ is low.
TOUT		O/Z	Timer output. TOUT signals a pulse when the on-chip timer counts down past zero. The pulse is one CLKOUT cycle wide. TOUT also goes into the high-impedance state when $\overline{\text{OFF}}$ is low.
<b>MULTICHANNEL BUFFERED SERIAL PORT SIGNALS</b>			
BCLKR0 BCLKR1 BCLKR2	Schmitt trigger	I/O/Z	Receive clocks. BCLKR serves as the serial shift clock for the buffered serial-port receiver. Input from an external clock source for clocking data into the McBSP. When not being used as a clock, these pins can be used as general-purpose I/O by setting RIOEN = 1.  BCLKR can be configured as an output by the way of the CLKRM bit in the PCR register.
BDR0 BDR1 BDR2		I	Buffered serial data receive (input) pin. When not being used as data-receive pins, these pins can be used as general-purpose I/O by setting RIOEN = 1.
BFSR0 BFSR1 BFSR2		I/O/Z	Frame synchronization pin for buffered serial-port input data. The BFSR pulse initiates the receive-data process over the BDR pin. When not being used as data-receive synchronization pins, these pins can be used as general-purpose I/O by setting RIOEN = 1.
BCLKX0 BCLKX1 BCLKX2	Schmitt trigger	I/O/Z	Transmit clocks. Clock signal used to clock data from the transmit register. This pin can also be configured as an input by setting the CLKXM = 0 in the PCR register. When not being used as a clock, these pins can be used as general-purpose I/O by setting XIOEN = 1.  These pins are placed into the high-impedance state when $\overline{\text{OFF}}$ is low.

† I = Input, O = Output, Z = High-impedance, S = Supply

‡ Although this pin includes an internal pulldown resistor, a 470- $\Omega$  external pulldown is required. If the  $\overline{\text{TRST}}$  pin is connected to multiple DSPs, a buffer is recommended to ensure the  $V_{IL}$  and  $V_{IH}$  specifications are met.

Table 2–2. Terminal Functions (Continued)

TERMINAL NAME	INTERNAL PIN STATE	I/O†	DESCRIPTION	
<b>MULTICHANNEL BUFFERED SERIAL PORT SIGNALS (CONTINUED)</b>				
BDX0 BDX1 BDX2		O/Z	Buffered serial-port transmit (output) pin. When not being used as data-transmit pins, these pins can be used as general-purpose I/O by setting XIOEN = 1.  These pins are placed into the high-impedance state when $\overline{OFF}$ is low.	
BFSX0 BFSX1 BFSX2		I/O/Z	Buffered serial-port frame synchronization pin for transmitting data. The BFSX pulse initiates the transmit-data process over BDX pin. If RS is asserted when BFSX is configured as output, then BFSX is turned into input mode by the reset operation. When not being used as data-transmit synchronization pins, these pins can be used as general-purpose I/O by setting XIOEN = 1.  These pins are placed into the high-impedance state when $\overline{OFF}$ is low.	
<b>HOST-PORT INTERFACE SIGNALS</b>				
<b>SECONDARY</b>			<b>PRIMARY</b>	
HA15 – HA0	Bus holders available	I/O/Z	A15 – A0	O/Z
These pins can be used to address internal memory via the HPI when the HPI16 pin is high. The sixteen address pins, A15 to A0, are multiplexed to transfer address between the core CPU and external data/program memory, I/O devices, or HPI in 16-bit mode.  The address bus includes bus holders to reduce the static power dissipation caused by floating, unused pins. The bus holders also eliminate the need for external bias resistors on unused pins. When the address bus is not being driven by the 5409, the bus holders keep the pins at the logic level that was most recently driven. The address bus holders of the 5409 are disabled at reset, and can be enabled/disabled via the HBH bit of the BSCR.				
HD15 – HD0	Bus holders available	I/O/Z	D15 – D0	O/Z
These pins can be used to read/write internal memory via the HPI when the HPI16 pin is high. The sixteen data pins, D15 to D0, are multiplexed to transfer data between the core CPU and external data/program memory, I/O devices, or HPI in 16-bit mode. The data bus is placed in the high-impedance state when not outputting or when RS or HOLD is asserted. The data bus also goes into the high-impedance state when $\overline{OFF}$ is low.  The data bus includes bus holders to reduce the static power dissipation caused by floating, unused pins. The bus holders also eliminate the need for external bias resistors on unused pins. When the data bus is not being driven by the 5409, the bus holders keep the pins at the logic level that was most recently driven. The data bus holders of the 5409 are disabled at reset, and can be enabled/disabled via the BH bit of the BSCR.				
HD7 – HD0	Bus holders available	I/O/Z	Parallel bidirectional data bus. When the HPI is disabled or when the HPI16 pin is high, these pins can also be used as general-purpose I/O pins. HD7–HD0 are placed in the high-impedance state when not outputting data or when $\overline{OFF}$ is low.  The HPI data bus includes bus holders to reduce the static power dissipation caused by floating, unused pins. When the HPI data bus is not being driven by the 5409, the bus holders keep the pins at the logic level that was most recently driven. The HPI data bus holders are disabled at reset. In 8-bit mode the bus holders can be enabled/disabled via the HBH bit of the BSCR. In 16-bit mode the bus holders are always active on the HD7–HD0 pins.	

† I = Input, O = Output, Z = High-impedance, S = Supply

‡ Although this pin includes an internal pulldown resistor, a 470-Ω external pulldown is required. If the  $\overline{TRST}$  pin is connected to multiple DSPs, a buffer is recommended to ensure the  $V_{IL}$  and  $V_{IH}$  specifications are met.

Table 2–2. Terminal Functions (Continued)

TERMINAL NAME	INTERNAL PIN STATE	I/O†	DESCRIPTION
<b>HOST-PORT INTERFACE SIGNALS (CONTINUED)</b>			
HCNTL0 HCNTL1	Pullup resistor	I	Control. HCNTL0 and HCNTL1 select a host access to one of the three HPI registers. The control inputs have internal pullup resistors that are only enabled when HPIENA = 0.
HBIL	Pullup resistor	I	Byte identification. HBIL identifies the first or second byte of transfer. The HBIL input has an internal pullup resistor that is only enabled when HPIENA = 0.
$\overline{\text{HCS}}$	Schmitt trigger/pullup resistor	I	Chip select. $\overline{\text{HCS}}$ is the select input for the HPI and must be driven low during accesses. The chip-select input has an internal pullup resistor that is only enabled when HPIENA = 0.
$\overline{\text{HDS1}}$ $\overline{\text{HDS2}}$	Schmitt trigger/pullup resistor	I	Data strobe. $\overline{\text{HDS1}}$ and $\overline{\text{HDS2}}$ are driven by the host read and write strobes to control transfers. The strobe inputs have internal pullup resistors that are only enabled when HPIENA = 0.
$\overline{\text{HAS}}$	Schmitt trigger/pullup resistor	I	Address strobe. Hosts with multiplexed address and data pins require $\overline{\text{HAS}}$ to latch the address in the HPIA register. HAS has an internal pullup resistor that is only enabled when HPIENA = 0.
HR/ $\overline{\text{W}}$	Pullup resistor	I	Read/write. HR/ $\overline{\text{W}}$ controls the direction of an HPI transfer. R/ $\overline{\text{W}}$ has an internal pullup resistor that is only enabled when HPIENA = 0.
HRDY		O/Z	Ready. The ready output informs the host when the HPI is ready for the next transfer. HRDY goes into the high-impedance state when OFF is low.
$\overline{\text{HINT}}$		O/Z	Interrupt. This output is used to interrupt the host. When the DSP is in reset, $\overline{\text{HINT}}$ is driven high. The signal goes into the high-impedance state when OFF is low.
HPIENA	Pulldown resistor	I	HPI module select. HPIENA must be driven high during reset to enable the HPI. An internal pulldown resistor is always active and the HPIENA pin is sampled on the rising edge of RS. If HPIENA is left open or is driven low during reset, the HPI module is disabled. Once the HPI is disabled, the HPIENA pin has no effect until the 5409 is reset.
HPI16	Pulldown resistor	I	HPI 16-bit select pin (internal pulldown, default HPI8). HPI16 = 1 selects the non-multiplexed mode. The non-multiplexed mode allows hosts with separate address/data buses to access the HPI address range via the 16 address pins (A15–A0). 16-bit data is also accessible through pins D0 through D15. Host-to-DSP and DSP-to-Host interrupts are not supported. There are no HPIC and HPIA register accesses in the non-multiplexed mode.  The HPI16 pin is sampled at RESET. The user should never change the value of the HPI16 pin while the RESET signal is HIGH.
<b>SUPPLY PINS</b>			
CVDD		S	+VDD. Dedicated 1.8-V power supply for the core CPU
DVDD		S	+VDD. Dedicated 3.3-V power supply for the I/O pins
VSS		S	Ground

† I = Input, O = Output, Z = High-impedance, S = Supply

‡ Although this pin includes an internal pulldown resistor, a 470- $\Omega$  external pulldown is required. If the  $\overline{\text{TRST}}$  pin is connected to multiple DSPs, a buffer is recommended to ensure the  $V_{IL}$  and  $V_{IH}$  specifications are met.

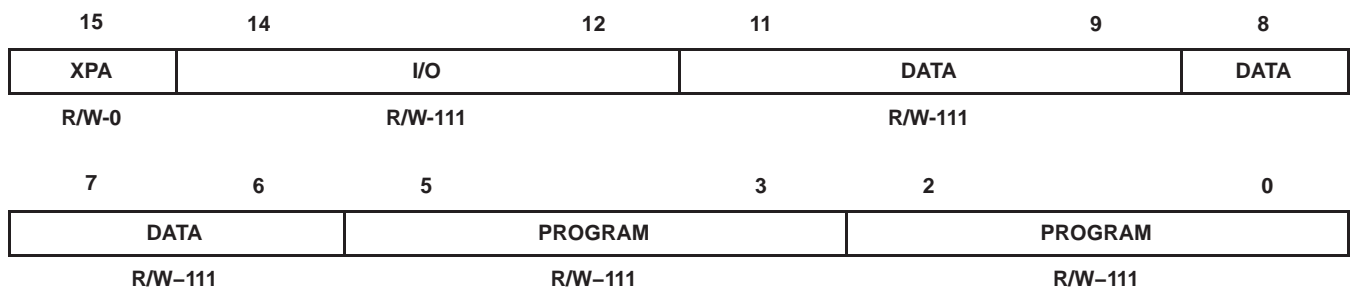
Table 2–2. Terminal Functions (Continued)

TERMINAL NAME	INTERNAL PIN STATE	I/O†	DESCRIPTION
<b>TEST PINS</b>			
TCK	Schmitt trigger/pullup resistor	I	IEEE standard 1149.1 test clock. TCK is normally a free-running clock signal with a 50% duty cycle. The changes on the test access port (TAP) of input signals TMS and TDI are clocked into the TAP controller, instruction register, or selected test data register on the rising edge of TCK. Changes at the TAP output signal (TDO) occur on the falling edge of TCK.
TDI	Pullup resistor	I	IEEE standard 1149.1 test data input pin with internal pullup device. TDI is clocked into the selected register (instruction or data) on a rising edge of TCK.
TDO		O/Z	IEEE standard 1149.1 test data output. The contents of the selected register (instruction or data) are shifted out of TDO on the falling edge of TCK. TDO is in the high-impedance state <u>except</u> when the scanning of data is in progress. TDO also goes into the high-impedance state when OFF is low.
TMS	Pullup resistor	I	IEEE standard 1149.1 test mode select. Pin with internal pullup device. This serial control input is clocked into the TAP controller on the rising edge of TCK.
$\overline{\text{TRST}}\ddagger$	Pulldown resistor	I	IEEE standard 1149.1 test reset. $\overline{\text{TRST}}$ , when high, gives the IEEE standard 1149.1 scan system control of the operations of the device. If TRST is driven low, the device operates in its functional mode, and the IEEE standard 1149.1 signals are ignored. Pin with internal pulldown device.
EMU0		I/O/Z	Emulator 0 pin. When $\overline{\text{TRST}}$ is driven low, EMU0 must be high for activation of the $\overline{\text{OFF}}$ condition. When $\overline{\text{TRST}}$ is driven high, EMU0 is used as an interrupt to or from the emulator system and is defined as input/output by way of the IEEE standard 1149.1 scan system.
EMU1/ $\overline{\text{OFF}}$		I/O/Z	Emulator 1 pin/disable all outputs. When $\overline{\text{TRST}}$ is driven high, EMU1/ $\overline{\text{OFF}}$ is used as an interrupt to or from the emulator system and is defined as input/output by way of the IEEE standard 1149.1 scan system. When $\overline{\text{TRST}}$ is driven low, EMU1/ $\overline{\text{OFF}}$ is configured as $\overline{\text{OFF}}$ . The EMU1/ $\overline{\text{OFF}}$ signal, when active low, puts all output drivers into the high-impedance state. Note that $\overline{\text{OFF}}$ is used exclusively for testing and emulation purposes (not for multiprocessing applications). Therefore, for the $\overline{\text{OFF}}$ feature, the following apply: $\overline{\text{TRST}} = \text{low}$ $\text{EMU0} = \text{high}$ $\text{EMU1}/\overline{\text{OFF}} = \text{low}$

† I = Input, O = Output, Z = High-impedance, S = Supply

‡ Although this pin includes an internal pulldown resistor, a 470- $\Omega$  external pulldown is required. If the  $\overline{\text{TRST}}$  pin is connected to multiple DSPs, a buffer is recommended to ensure the  $V_{IL}$  and  $V_{IH}$  specifications are met.





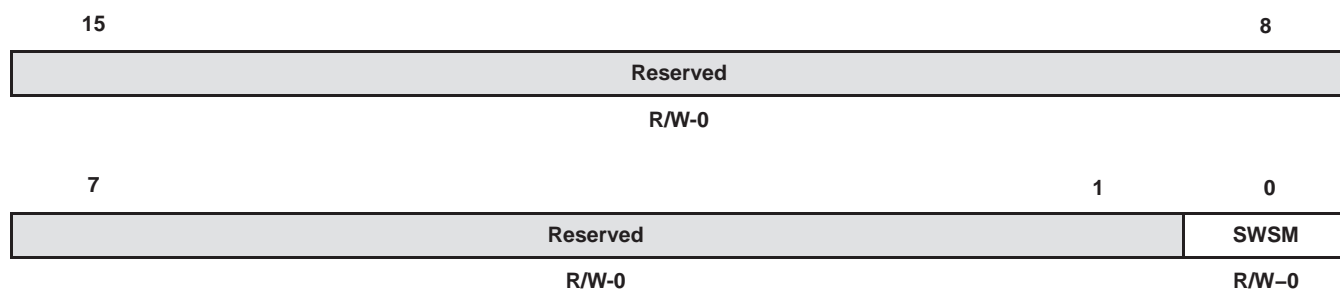
**LEGEND:** R = Read, W = Write, n = value present after reset

**Figure 3–2. Software Wait-State Register (SWWSR) [Memory-Mapped Register (MMR) Address 0028h]**

**Table 3–1. Software Wait-State Register (SWWSR) Bit Fields**

BIT NO.	BIT NAME	RESET VALUE	FUNCTION
15	XPA	0	Extended program address control bit. XPA is used in conjunction with the program space fields (bits 0 through 5) to select the address range for program space wait states.
14–12	I/O	1	I/O space. The field value (0–7) corresponds to the base number of wait states for I/O space accesses within addresses 0000–FFFFh. The SWSM bit of the SWCR defines a multiplication factor of 1 or 2 for the base number of wait states.
11–9	Data	1	Upper data space. The field value (0–7) corresponds to the base number of wait states for external data space accesses within addresses 8000–FFFFh. The SWSM bit of the SWCR defines a multiplication factor of 1 or 2 for the base number of wait states.
8–6	Data	1	Lower data space. The field value (0–7) corresponds to the base number of wait states for external data space accesses within addresses 0000–7FFFh. The SWSM bit of the SWCR defines a multiplication factor of 1 or 2 for the base number of wait states.
5–3	Program	1	Upper program space. The field value (0–7) corresponds to the base number of wait states for external program space accesses within the following addresses: <input type="checkbox"/> XPA = 0: x8000 – xFFFFh <input type="checkbox"/> XPA = 1: The upper program space bit field has no effect on wait states. The SWSM bit of the SWCR defines a multiplication factor of 1 or 2 for the base number of wait states.
2–0	Program	1	Program space. The field value (0–7) corresponds to the base number of wait states for external program space accesses within the following addresses: <input type="checkbox"/> XPA = 0: x0000–x7FFFh <input type="checkbox"/> XPA = 1: 00000–FFFFFh The SWSM bit of the SWCR defines a multiplication factor of 1 or 2 for the base number of wait states.

The software wait-state multiplier bit of the software wait-state configuration register is used to extend the base number of wait states selected by the SWWSR. The SWCR bit fields are shown in Figure 3–3 and described in Table 3–2.



LEGEND: R = Read, W = Write, *n* = value present after reset

**Figure 3–3. Software Wait-State Configuration Register (SWCR) [MMR Address 002Bh]**

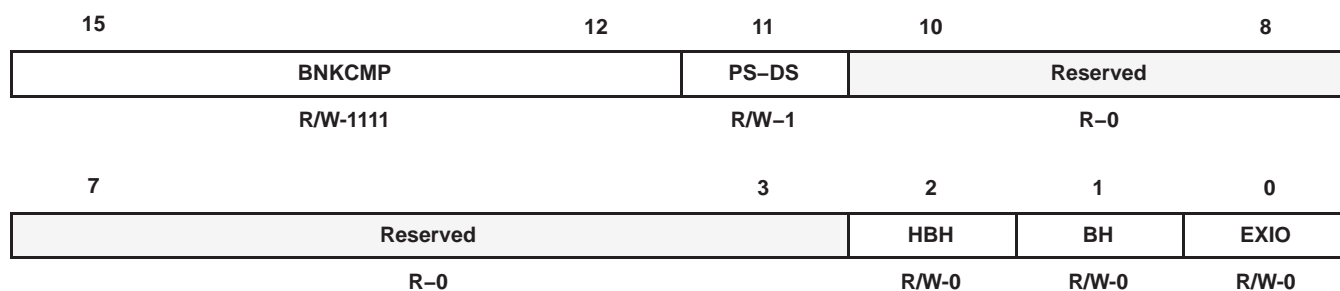
**Table 3–2. Software Wait-State Configuration Register (SWCR) Bit Fields**

PIN NO.	PIN NAME	RESET VALUE	FUNCTION
15–1	Reserved	0	These bits are reserved and are unaffected by writes.
0	SWSM	0	Software wait-state multiplier. Used to multiply the number of wait states defined in the SWWSR by a factor of 1 or 2. <input type="checkbox"/> SWSM = 0: wait-state base values are unchanged (multiplied by 1). <input type="checkbox"/> SWSM = 1: wait-state base values are multiplied by 2 for a maximum of 14 wait states.

### 3.1.2 Programmable Bank-Switching Wait States

The programmable bank-switching logic of the 5409 is functionally equivalent to that of the 548/549 devices. This feature automatically inserts one cycle when accesses cross memory-bank boundaries within program or data memory space. A bank-switching wait state can also be automatically inserted when accesses cross the data space boundary into program space.

The bank-switching control register (BSCR) defines the bank size for bank-switching wait-states. Figure 3–4 shows the BSCR and its bits are described in Table 3–3.



LEGEND: R = Read, W = Write, *n* = value present after reset

**Figure 3–4. Bank-Switching Control Register (BSCR) [MMR Address 0029h]**

**Table 3–3. Bank-Switching Control Register Fields**

BIT NO. NAME	RESET VALUE	FUNCTION
15–12 BNKCMP	1111	Bank compare. BNKCMP determines the external memory-bank size. BNKCMP is used to mask the four MSBs of an address. For example, if BNKCMP = 1111b, the four MSBs (bits 12–15) are compared, resulting in a bank size of 4K words. Bank sizes of 4K words to 64K words are allowed.
11 PS-DS	1	Program read – data read access. PS-DS inserts an extra cycle between consecutive accesses of program read and data read or data read and program read. PS-DS = 0 No extra cycles are inserted by this feature. PS-DS = 1 One extra cycle is inserted between consecutive data and program reads.
10–3 Reserved	0	These bits are reserved and are unaffected by writes.
2 HBH	0	HPI bus holder. HBH controls the HPI bus holder feature. HBH is cleared to 0 at reset. <b>8-bit Mode</b> HBH = 0 The bus holder is disabled for the HPI data bus (HD[7:0]). HBH = 1 The bus holders are enabled on HD[7:0]. When not driven, the HPI data bus (HD[7:0]) is held in the previous logic level.
		HPI bus holder. HBH controls the HPI bus holder feature. HBH is cleared to 0 at reset. <b>16-bit Mode</b> HBH = 0 The bus holder is disabled for the HPI address bus (HA[15:0]). The HPI GPIO pins (HD[7:0]) are held in the previous logic level. HBH = 1 The bus holders are enabled on HA[15:0]. When not driven, the HPI address bus (A[15:0]) and HPI GPIO pins (HD[7:0]) are held in the previous logic level.
1 BH	0	Bus holder. BH controls the data bus holder feature. BH is cleared to 0 at reset. BH = 0 The bus holder is disabled. BH = 1 The bus holder is enabled. When not driven, the data bus (D[15:0]) is held in the previous logic level.
0 EXIO	0	External bus interface off. The EXIO bit controls the external bus-off function. EXIO = 0 The external bus interface functions as usual. EXIO = 1 The address bus, data bus, and control signals become inactive after completing the current bus cycle. Note that the DROM, MP/MC, and OVLY bits in the PMST and the HM bit of ST1 cannot be modified when the interface is disabled.



### 3.1.3 CPU Memory-Mapped Registers

The 5409 has 27 memory-mapped CPU registers, which are mapped in data memory space addresses 0h to 1Fh.

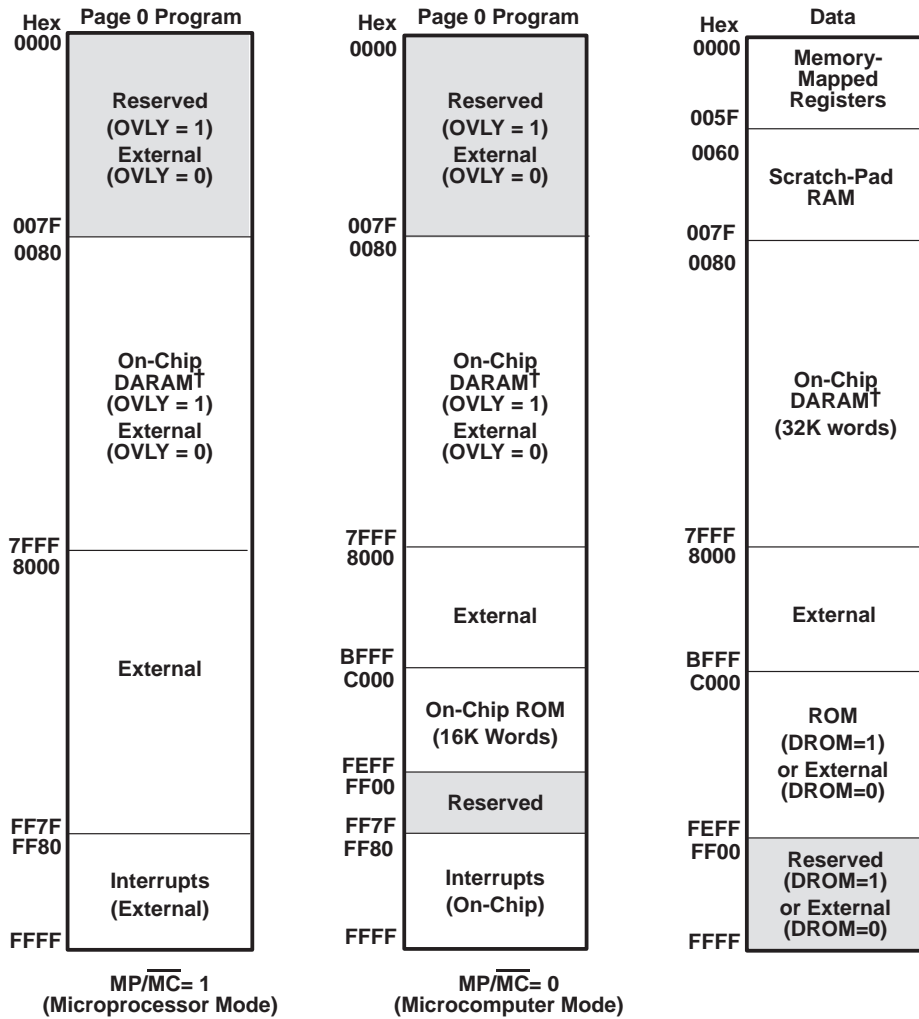
**Table 3–4. CPU Memory-Mapped Registers**

NAME	ADDRESS		DESCRIPTION
	DEC	HEX	
IMR	0	0	Interrupt mask register
IFR	1	1	Interrupt flag register
–	2–5	2–5	Reserved for testing
ST0	6	6	Status register 0
ST1	7	7	Status register 1
AL	8	8	Accumulator A low word (15–0)
AH	9	9	Accumulator A high word (31–16)
AG	10	A	Accumulator A guard bits (39–32)
BL	11	B	Accumulator B low word (15–0)
BH	12	C	Accumulator B high word (31–16)
BG	13	D	Accumulator B guard bits (39–32)
TREG	14	E	Temporary register
TRN	15	F	Transition register
AR0	16	10	Auxiliary register 0
AR1	17	11	Auxiliary register 1
AR2	18	12	Auxiliary register 2
AR3	19	13	Auxiliary register 3
AR4	20	14	Auxiliary register 4
AR5	21	15	Auxiliary register 5
AR6	22	16	Auxiliary register 6
AR7	23	17	Auxiliary register 7
SP	24	18	Stack pointer register
BK	25	19	Circular buffer size register
BRC	26	1A	Block repeat counter
RSA	27	1B	Block repeat start address
REA	28	1C	Block repeat end address
PMST	29	1D	Processor mode status (PMST) register
XPC	30	1E	Extended program page register
–	31	1F	Reserved

### 3.2 Memory

The 5409 device provides both on-chip ROM and RAM memories to aid in system performance and integration.

#### 3.2.1 Memory Map



† DARAM0= 0060h – 1FFFh, DARAM1= 2000h – 3FFFh  
 DARAM2= 4000h – 5FFFh, DARAM3= 6000h – 7FFFh

Figure 3–5. Memory Map

### 3.2.2 On-Chip ROM With Bootloader

A bootloader is available in the standard 5409 on-chip ROM. This bootloader can be used to automatically transfer user code from an external source to anywhere in the program memory at power up. If the  $\overline{MP/\overline{MC}}$  pin is sampled low during a hardware reset, execution begins at location FF80h of the on-chip ROM. This location contains a branch instruction to the start of the bootloader program. The standard 5409 bootloader provides different ways to download the code to accommodate various system requirements:

- Parallel from 8-bit or 16-bit-wide EPROM
- Parallel from I/O space 8-bit or 16-bit mode
- Serial boot from serial ports 8-bit or 16-bit mode
- Host-port interface boot
- SPI serial EEPROM 8-bit boot mode

The standard on-chip ROM layout is shown in Table 3–5.

**Table 3–5. Standard On-Chip ROM Layout†**

ADDRESS RANGE	DESCRIPTION
0x0000h – 0xBFFFh	External program space
0xC000h – 0xF7FFh	Reserved
0xF800h – 0xFBFFh	Bootloader
0xFC00h – 0xFEFFh	Reserved
0xFF00h – 0xFF7Fh	Reserved†
0xFF80h – 0xFFFFh	Interrupt vector table

† In the VC5409 ROM, 128 words are reserved for factory device-testing purposes. Application code to be implemented in on-chip ROM must reserve these 128 words at addresses FF00h–FF7Fh in program space.

### 3.2.3 On-Chip RAM

The 5409 device contains  $32K \times 16$ -bit of on-chip dual-access RAM (DARAM). The DARAM is composed of four blocks of 8K words each. Each block in the DARAM can support two reads in one cycle, or a read and a write in one cycle. The DARAM is located in the address range 0080h–7FFFh in data space, and can be mapped into program/data space by setting the OVLY bit to one.

### 3.2.4 On-Chip Memory Security

The 5409 features a  $16K\text{-word} \times 16\text{-bit}$  on-chip maskable ROM.

Customers can arrange to have the ROM of the 5409 programmed with contents unique to any particular application. A security option is available to protect a custom ROM. The ROM and ROM/RAM security options are available on the 5409. These security options are described in the *TMS320C54x DSP Reference Set, Volume 1: CPU and Peripherals* (literature number SPRU131). When the security options are enabled, JTAG emulation is inhibited or nonfunctional.

### 3.2.5 Relocatable Interrupt Vector Table

The reset, interrupt, and trap vectors are addressed in program space. These vectors are soft — meaning that the processor, when taking the trap, loads the program counter (PC) with the trap address and executes the code at the vector location. Four words are reserved at each vector location to accommodate a delayed branch instruction, either two 1-word instructions or one 2-word instruction, which allows branching to the appropriate interrupt service routine with minimal overhead.

At device reset, the reset, interrupt, and trap vectors are mapped to address FF80h in program space. However, these vectors can be remapped to the beginning of any 128-word page in program space after device reset. This is done by loading the interrupt vector pointer (IPTR) bits in the PMST register with the appropriate 128-word page boundary address. After loading IPTR, any user interrupt or trap vector is mapped to the new 128-word page.

**NOTE:**The hardware reset ( $\overline{RS}$ ) vector cannot be remapped because a hardware reset loads the IPTR with 1s. Therefore, the reset vector is always fetched at location FF80h in program space.

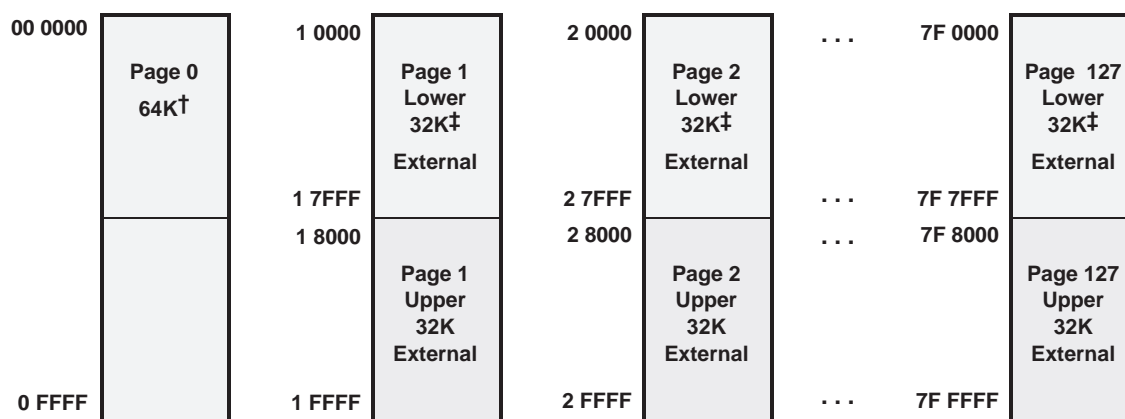
### 3.2.6 Extended Program Memory

The 5409 CPU uses a paged extended memory scheme in program space to allow access of up to 8M program memory locations. In order to implement this scheme, the 5409 includes several features that are also present on the 548/549 devices:

- Twenty-three address lines, instead of sixteen
- An extra memory-mapped register, the XPC register defines the page selection. This register is memory-mapped into data space to address 001Eh. At a hardware reset, the XPC is initialized to 0.
- Six extra instructions for addressing extended program space. These six instructions affect the XPC.
  - *FB[D]* pmad (23 bits) – Far branch
  - *FBACC[D]* Accu[22:0] – Far branch to the location specified by the value in accumulator A or accumulator B
  - *FCALL[D]* pmad (23 bits) – Far call
  - *FCALA[D]* Accu[22:0] – Far call to the location specified by the value in accumulator A or accumulator B
  - *FRET[D]* – Far return
  - *FRETE[D]* – Far return with interrupts enabled
- In addition to these new instructions, two 54x instructions are extended to use 23 bits in the 5409:
  - READA data\_memory (using 23-bit accumulator address)
  - WRITA data\_memory (using 23-bit accumulator address)

All other instructions, software interrupts, and hardware interrupts do not modify the XPC register and access only memory within the current page.

Program memory in the 5409 is organized into 127 pages that are each 64K in length, as shown in Figure 3–6.



<sup>†</sup> Refer to Figure 1. 5409 Memory Map.

<sup>‡</sup> The Lower 32K words of pages 1 through 126 are available only when the OVLY bit is cleared to 0. If the OVLY bit is set to 1, the on-chip RAM is mapped to the lower 32K words of all program space pages.

**Figure 3–6. Extended Program Memory**

### 3.3 On-Chip Peripherals

The 5409 device has the following peripherals:

- An enhanced 8-bit host-port interface (HPI8/16) with 16-bit data/addressing
- Three multichannel buffered serial ports (McBSPs)
- One hardware timer
- A clock generator with a phase-locked loop (PLL)
- A direct memory access (DMA) controller

#### 3.3.1 Parallel I/O Ports

The 5409 CPU has a total of 64K I/O ports. These ports can be addressed by the PORTR instruction or the PORTW instruction. The  $\overline{IS}$  signal indicates a read/write operation through an I/O port. The 5409 can interface easily with external devices through the I/O ports while requiring minimal off-chip address-decoding circuits.

##### 3.3.1.1 Enhanced 8-Bit Host-Port Interface (HPI8/16)

The 5409 host-port interface, also referred to as the HPI8/16, is an enhanced version of the standard 8-bit HPI found on earlier 54x DSPs (542, 545, 548, and 549). The HPI8/16 is an 8-bit parallel port for interprocessor communication. The features of the HPI8/16 include:

Standard features:

- Sequential transfers (with autoincrement) or random-access transfers
- Host interrupt and 54x interrupt capability
- Multiple data strobes and control pins for interface flexibility

Enhanced features of the 5409 HPI8/16:

- Access to entire on-chip RAM through DMA bus
- Capability to continue transferring during emulation stop
- Capability to transfer 16-bit address and 16-bit data (non-multiplexed mode)

The HPI8/16 functions as a slave and enables the host processor to access the on-chip memory of the 5409. A major enhancement to the 5409 HPI over previous versions is that it allows host access to the entire on-chip memory range of the DSP. The HPI8/16 does not have access to external memory. The host and the DSP both have access to the on-chip RAM at all times and host accesses are always synchronized to the DSP clock. If the host and the DSP contend for access to the same location, the host has priority, and the DSP waits for one HPI8/16 cycle. Note that since host accesses are always synchronized to the 5409 clock, an active input clock (CLKIN) is required for HPI8/16 accesses during IDLE states, and host accesses are not allowed while the 5409 reset pin is asserted.

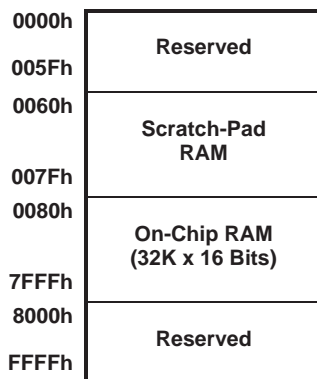


Figure 3–7. 5409 HPI Memory Map

### 3.3.1.2 Standard 8-Bit Mode

The HPI8/16 interface consists of an 8-bit bidirectional data bus and various control signals. Sixteen-bit transfers are accomplished in two parts with the HBIL input designating high or low byte. The host communicates with the HPI8 through three dedicated registers — HPI address register (HPIA), HPI data register (HPID), and an HPI control register (HPIC). The HPIA and HPID registers are only accessible by the host, and the HPIC register is accessible by both the host and the 5409. If the HPI is disabled (HPIENA = 0) or in HPI16 mode (HPI16 = 1), the 8-bit bidirectional data pins HD0–HD7 can be used as general-purpose input/output (GPIO).

### 3.3.1.3 16-Bit Nonmultiplexed Mode

In *nonmultiplexed* mode, a host with separate address/data buses can access the HPI16 data register (HPID) via the HD 16-bit bidirectional data bus, and the address register (HPIA) via the 16-bit HA address bus, external address and data pins, A0–A15 and D0–D15, respectively. The host initiates an access with the strobe signals (HDS1, HDS2, HCS) and controls the direction of the access with the HR $\bar{W}$  signal. The HPI16 can stall host accesses via the HRDY signal. Note that the HPIC register is not available in *nonmultiplexed* mode since there are no HCNTL signals available. All host accesses initiate a DMA read or write access. The HPI16 nonmultiplexed mode does not support host-to-DSP and DSP-to-host interrupts. When the HPI is disabled or in HPI16 mode, HD0–HD7 can be configured as general-purpose input/output (GPIO). The HPI16 pin is sampled at RESET. The HPI16 pin should never be changed while the device RESET is HIGH.

### 3.3.1.3.1 Host Bus Holder Configuration

The 5409 has two bus holder control bits, BH (BSCR[1]) and HBH (BSCR[2]), to control the bus keepers of the address bus (A[15–0]), data bus (D[15–0]) and the HPI data bus (HD[7–0]). The bus keeper enabling/disabling is described in Table 5.

**Table 3–6. Bus Holder Control Bits**

HPI16 pin	BH	HBH	D[15–0]	A[15–0]	HD[7–0]
0	0	0	OFF	OFF	OFF
0	0	1	OFF	OFF	ON
0	1	0	ON	OFF	OFF
0	1	1	ON	OFF	ON
1	0	0	OFF	OFF	ON
1	0	1	OFF	ON	ON
1	1	0	ON	OFF	ON
1	1	1	ON	ON	ON

The HPI bus holders are activated via the HBH bit in the Bank Switch Control Register (BSCR). The HBH bit can control bus holder behavior for both the 8-bit and 16-bit modes. In the 8-bit mode, the HBH bit controls the bus holders on the host data pins HD7–HD0. When HBH = 1, the host data bus holders are active. When HBH = 0 the host data bus holders are inactive. In the 16-bit nonmultiplexed mode, the bus holders for pins HD7–HD0 are always active; however, the HBH bit controls the host address pins A15–A0. When HBH = 1, the host address bus holders are active. When HBH = 0, the host address bus holders are inactive.

### 3.3.1.4 Operation During IDLE2

The HPI can continue to operate during IDLE1 or IDLE2 by using special clock management logic that turns on relevant clocks to perform a synchronous memory access, and then turns the clocks back off to save power. The DSP CPU does not wake up from the IDLE mode during this process.

### 3.3.2 Multichannel Buffered Serial Ports (McBSPs)

The 5409 device has three high-speed, full-duplex multichannel buffered serial ports (McBSPs) that allow direct interface to other C54x/LC54x devices, codecs, and other devices in a system. The McBSPs are based on the standard serial port interface found on other 54x devices. Like its predecessors, the McBSP provides:

- Full-duplex communication
- Double-buffer data registers, which allow a continuous data stream
- Independent framing and clocking for receive and transmit

In addition, the McBSP has the following capabilities:

- Direct interface to:
  - T1/E1 framers
  - MVIP switching-compatible and ST-BUS compliant devices
  - IOM-2 compliant devices
  - AC97-compliant devices
  - Serial peripheral interface (SPI) devices
- Multichannel transmit and receive of up to 32 channels in a 128 channel stream.
- A wide selection of data sizes including 8, 12, 16, 20, 24, or 32 bits
- $\mu$ -law and A-law companding
- Programmable polarity for both frame synchronization and data clocks
- Programmable internal clock and frame generation

For detailed information on the standard features of the McBSP, refer to the *TMS320C54x DSP Reference Set, Volume 5: Enhanced Peripherals*, (literature number SPRU302).

Although the BCLKS pin is not available on the 5409 PGE and GGU packages, the 5409 is capable of synchronization to external clock sources. BCLKX or BCLKR can be used by the sample rate generator for external synchronization. The sample rate clock mode extended (SCLKME) bit field is located in the PCR to accommodate this option.

15	14	13	12	11	10	9	8
Reserved		XIOEN	RIOEN	FSXM	FSRM	CLKXM	CLKRM
RW		RW	RW	RW	RW	RW	RW
7	6	5	4	3	2	1	0
SCLKME	CLKS STAT	DX STAT	DR STAT	FSXP	FSRP	CLKXP	CLKRP
RW	RW	RW	RW	RW	RW	RW	RW

LEGEND: R = Read, W = Write

Figure 3–8. Pin Control Register (PCR)



Table 3–7. Pin Control Register (PCR) Bit Field Description

BIT	NAME	FUNCTION
15 – 14	Reserved	Reserved. Pins are not used.
13	XIOEN	<p>Transmit/Receive general-purpose I/O mode ONLY when <math>\overline{XRST}=0</math> in the SPCR(1/2)</p> <p>XIOEN = 0 DX pin is not a general-purpose output. FSX and CLKX are not general-purpose I/Os.  XIOEN = 1 DX pin is a general-purpose output. FSX and CLKX are general-purpose I/Os. These serial port pins do not perform serial port operations.</p>
12	RIOEN	<p>Transmit/Receive general-purpose I/O mode ONLY when <math>\overline{RRST}=0</math> in the SPCR(1/2)</p> <p>RIOEN = 0 DR and CLKS pins are not general-purpose inputs. FSR and CLKR are not general-purpose I/Os.  RIOEN = 1 DR and CLKS pins are general-purpose inputs. FSR and CLKR are general-purpose I/Os. These serial port pins do not perform serial port operations. The CLKS pin is affected by a combination of <math>\overline{RRST}</math> and RIOEN signals of the receiver.</p>
11	FSXM	<p>Transmit frame synchronization mode</p> <p>FSRM = 0 Frame synchronization signal derived from an external source.  FSRM = 1 Frame synchronization is determined by the sample rate generator frame synchronization mode bit (FSGM) in the SRGR2.</p>
10	FSRM	<p>Receive frame synchronization mode</p> <p>FSRM = 0 Frame synchronization pulses generated by an external device. FSR is an input pin.  FSRM = 1 Frame synchronization generated internally by the sample rate generator. FSR is an output pin except when GSYNC=1 in the SRGR.</p>
9	CLKXM	<p>Transmitter clock mode</p> <p>CLKXM = 0 Receiver/transmitter clock is driven by an external clock with CLK(R/X) as an input pin  CLKXM = 1 CLK(R/X) is an output pin and is driven by the internal sample rate generator</p> <p>During SPI mode (CLKSTP is a non-zero value):</p> <p>CLKXM = 0 McBSP is a slave and clock (CLKX) is driven by the SPI master in the system. CLKR is internally driven by CLKX.  CLKXM = 1 McBSP is a master and generates the clock (CLKX) to drive its receive clock (CLKR) and the shift clock of the SPI-compliant slaves in the system.</p>
8	CLKRM	<p>Receiver clock mode</p> <p>Case 1: Digital loop-back mode is not set (DLB=0) in SPCR1.</p> <p>CLKRM = 0 Receive clock (CLKR) is an input pin driven by an external clock.  CLKRM = 1 CLKR is an output pin and is driven by the internal sample rate generator</p> <p>Case 2: Digital loop-back mode set (DLB=1) in SPCR1</p> <p>CLKRM = 0 Receive clock (Not the CLKR pin) is driven by transmit clock (CLKX), which is based on CLKXM bit in the PCR. CLKR pin is in high-impedance mode.  CLKRM = 1 CLKR is an output pin and is driven by the transmit clock. The transmit clock is derived based on the CLKXM bit in the PCR.</p>
7	SCLKME	<p>Sample rate clock mode extended</p> <p>SCLKME = 0 External clock via CLKS or CPU clock is used as a reference by the sample rate generator.  SCLKME = 1 External clock via CLKR or CLKX clock is used as a reference by the sample rate generator.</p>
6	CLKS STAT	CLKS pin status. CLKS STAT reflects value on CLKS pin when selected as a general-purpose input.

**Table 3–7. Pin Control Register (PCR) Bit Field Description (Continued)**

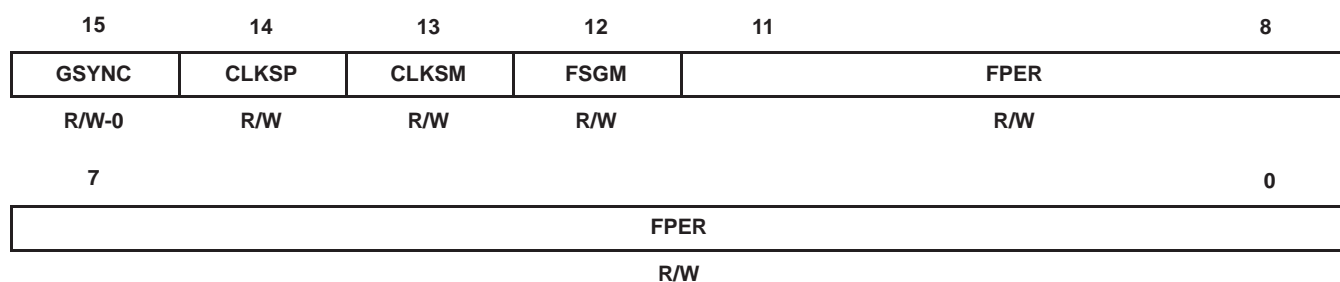
BIT	NAME	FUNCTION
5	DX STAT	DX pin status. DX STAT reflects value on DX pin when it is selected as a general-purpose output.
4	DR STAT	DR pin status. DR STAT reflects value on DR pin when it is selected as a general-purpose input.
3 2	FSXP FSRP	Receive/Transmit frame synchronization polarity. FS(R/X)P = 0 Frame synchronization pulse FS(R/X) is active high FS(R/X)P = 1 Frame synchronization pulse FS(R/X) is active low
1	CLKXP	Transmit clock polarity CLKXP = 0 Transmit data sampled on rising edge of CLKR CLKXP = 1 Transmit data sampled on falling edge of CLKR
0	CLKRP	Receive clock polarity CLKRP = 0 Receive data sampled on falling edge of CLKR CLKRP = 1 Receive data sampled on rising edge of CLKR

### 3.3.2.1 Sample Rate Generator

The 5409 sample rate generator has four clock input options that are only available when both the PCR and SRGR2 are used. Table 3–8 shows the sample rate generator clock input options.

**Table 3–8. Sample Rate Generator Clock Input Options**

MODE	SCLKME (PCR.7)	CLKSM (SRGR2.13)
CLKS pin	0	0
CPU	0	1
CLKR pin	1	0
CLKX pin	1	1



**LEGEND:** R = Read, W = Write, *n* = value present after reset

**Figure 3–9. Sample Rate Generator Register 2 (SRGR2)**

**Table 3–9. Sample Rate Generator Register 2 (SRGR2) Bit Field Descriptions**

BIT	NAME	FUNCTION
15	GSYNC	Sample rate generator clock synchronization. Only used when the external clock (CLKS) drives the sample rate generator clock (CLKSM=0)  GSYNC = 0 The sample rate generator clock (CLKG) is free-running. GSYNC = 1 The sample rate generator clock (CLKG) is running. But CLKG is resynchronized and frame sync signal (FSG) is generated only after detecting the receive frame synchronization signal (FSR). Also, frame period (FPER) is a don't care because the period is dictated by the external frame sync pulse.
14	CLKSP	CLKS polarity clock edge select. Only used when the external clock (CLKS) drives the sample rate generator clock (CLKSM=0).  CLKSP = 0 Rising edge of CLKS generates CLKG and FSG. CLKSP = 1 Falling edge of CLKS generates CLKG and FSG.
13	CLKSM	McBSP sample rate generator clock mode  SCLKME = 0 CLKSM = 0 Sample rate generator clock derived from the CLKS pin (in PCR) CLKSM = 1 Sample rate generator clock derived from CPU clock  SCLKME = 1 CLKSM = 0 Sample rate generator clock derived from CLKR pin (in PCR) CLKSM = 1 Sample rate generator clock derived from CLKX pin
12	FSGM	Sample rate generator transmit frame synchronization mode. Used when FSXM=1 in the PCR.  FSGM = 0 Transmit frame sync signal (FSX) due to DXR(1/2) copy FSGM = 1 Transmit frame sync signal driven by the sample rate generator frame sync signal (FSG)
11 – 0	FPER	Frame period. This determines when the next frame sync signal should become active. Range: up to 2 <sup>12</sup> ; 1 to 4096 CLKG periods.

### 3.3.2.2 McBSP Control Registers and Subaddresses

The control registers for the multichannel buffered serial port (McBSP) are accessed using the subbank addressing scheme. This allows a set or subbank of registers to be accessed through a single memory location. The serial port subbank address (SPSA) register is used as a pointer to select a particular register within the subbank. The serial port subbank data (SPSD) register is used to access (read or write) the selected register. Table 3–10 shows the McBSP control registers and their corresponding subaddresses.

**Table 3–10. McBSP Control Registers and Subaddresses**

McBSP0		McBSP1		McBSP2		SUB ADDRESS	DESCRIPTION
NAME	ADDRESS	NAME	ADDRESS	NAME	ADDRESS		
SPCR10	39h	SPCR11	49h	SPCR12	35h	00h	Serial port control register 1
SPCR20	39h	SPCR21	49h	SPCR22	35h	01h	Serial port control register 2
RCR10	39h	RCR11	49h	RCR12	35h	02h	Receive control register 1
RCR20	39h	RCR21	49h	RCR22	35h	03h	Receive control register 2
XCR10	39h	XCR11	49h	XCR12	35h	04h	Transmit control register 1
XCR20	39h	XCR21	49h	XCR22	35h	05h	Transmit control register 2
SRGR10	39h	SRGR11	49h	SRGR12	35h	06h	Sample rate generator register 1
SRGR20	39h	SRGR21	49h	SRGR22	35h	07h	Sample rate generator register 2
MCR10	39h	MCR11	49h	MCR12	35h	08h	Multichannel register 1
MCR20	39h	MCR21	49h	MCR22	35h	09h	Multichannel register 2
RCERA0	39h	RCERA1	49h	RCERA2	35h	0Ah	Receive channel enable register partition A
RCERB0	39h	RCERB1	49h	RCERB2	35h	0Bh	Receive channel enable register partition B
XCERA0	39h	XCERA1	49h	XCERA2	35h	0Ch	Transmit channel enable register partition A
XCERB0	39h	XCERB1	49h	XCERB2	35h	0Dh	Transmit channel enable register partition B
PCR0	39h	PCR1	49h	PCR2	35h	0Eh	Pin control register

### 3.3.3 Hardware Timer

The 5409 device features one 16-bit timing circuit with a 4-bit prescaler. The main counter of each timer is decremented by one every CPU clock cycle. Each time the counter decrements to 0, a timer interrupt is generated. The timer can be stopped, restarted, reset, or disabled by specific control bits.

### 3.3.4 Clock Generator

The clock generator provides clocks to the 5409 device, and consists of an internal oscillator and a phase-locked loop (PLL) circuit. The clock generator requires a reference clock input, which can be provided by using a crystal resonator with the internal oscillator, or from an external clock source. The reference clock input is then divided by two (DIV mode) to generate clocks for the 5409 device, or the PLL circuit can be used (PLL mode) to generate the device clock by multiplying the reference clock frequency by a scale factor, allowing use of a clock source with a lower frequency than that of the CPU. The PLL is an adaptive circuit that, once synchronized, locks onto and tracks an input clock signal.

When the PLL is initially started, it enters a transitional mode during which the PLL acquires lock with the input signal. Once the PLL is locked, it continues to track and maintain synchronization with the input signal. Then, other internal clock circuitry allows the synthesis of new clock frequencies for use as master clock for the 5409 device.

This clock generator allows system designers to select the clock source. The sources that drive the clock generator are:

- A crystal resonator circuit. The crystal resonator circuit is connected across the X1 and X2/CLKIN pins of the 5409 to enable the internal oscillator.
- An external clock. The external clock source is directly connected to the X2/CLKIN pin, and X1 is left unconnected.

The software-programmable PLL features a high level of flexibility, and includes a clock scaler that provides various clock multiplier ratios, capability to directly enable and disable the PLL, and a PLL lock timer that can be used to delay switching to PLL clocking mode of the device until lock is achieved. Devices that have a built-in software-programmable PLL can be configured in one of two clock modes:

- PLL mode. The input clock (X2/CLKIN) is multiplied by 1 of 31 possible ratios. These ratios are achieved using the PLL circuitry.
- DIV (divider) mode. The input clock is divided by 2 or 4. Note that when DIV mode is used, the PLL can be completely disabled in order to minimize power dissipation.

The software-programmable PLL is controlled using the 16-bit memory-mapped (address 0058h) clock mode register (CLKMD). The CLKMD register is used to define the clock configuration of the PLL clock module. Upon reset, the CLKMD register is initialized with a predetermined value dependent only upon the state of the CLKMD1 – CLKMD3 pins as shown in Table 3–11.

**Table 3–11. Clock Mode Settings at Reset**

CLKMD1	CLKMD2	CLKMD3	CLKMD RESET VALUE	CLOCK MODE
0	0	0	E007h	PLL x 15
0	0	1	9007h	PLL x 10
0	1	0	4007h	PLL x 5
1	0	0	1007h	PLL x 2
1	1	0	F007h	PLL x 1
1	1	1	0000h	1/2 (PLL disabled)
1	0	1	F000h	1/4 (PLL disabled)
0	1	1	—	Reserved

### 3.3.5 DMA Controller

The 5409 direct memory access (DMA) controller transfers data between points in the memory map without intervention by the CPU. The DMA controller allows movements of data to and from internal program/data memory, internal peripherals (such as the McBSPs), and external program/data memory to occur in the background of CPU operation. The DMA has six independent programmable channels allowing six different contexts for DMA operation.

The DMA has the following features:

- The DMA has external memory access.
- The DMA operates independently of the CPU.
- The DMA has six channels. The DMA can keep track of the contexts of six independent block transfers.
- The DMA has higher priority than the CPU for internal accesses.
- Each channel has independently programmable priorities.
- Each channel's source and destination address registers can have configurable indexes through memory on each read and write transfer, respectively. The address may remain constant, be post-incremented, post-decremented, or be adjusted by a programmable value.
- Each internal read or write transfer may be initialized by selected sync events.
- Each DMA channel is capable of sending interrupts to the CPU.
- The DMA can perform double-word transfers (a 32-bit transfer of two 16-bit words). (Internally only)

#### 3.3.5.1 DMA External Access

The 5409 DMA supports external accesses to extended program, extended data, and extended I/O memory. These overlay pages are only visible to the DMA controller. A maximum of two DMA channels can be used for external memory accesses. The DMA external accesses require 9 cycle minimums for external writes and 13 cycle minimums for external reads.

The control of the bus is arbitrated between the CPU and the DMA. While the DMA or CPU is in control of the external bus the other will be held-off via wait states until the current transfer is complete. The DMA takes precedence over XIO requests. The HOLD/HOLDA feature of the 5409 affects external CPU transfers as well as external DMA transfers. When an external processor asserts the HOLD pin to gain control of the memory interface, the HOLDA signal is not asserted until all pending DMA transfers are complete. To prevent the DMA from blocking out the CPU or HOLD/HOLDA feature from accessing the external bus, uninterrupted burst transfers are **not** supported by the DMA. Subsequently, CPU and DMA arbitration testing is performed for each external bus cycle, regardless of the bus activity.

- Only two channels are available for external accesses. (One for external reads/one for external writes.)
- Single-word (16-bit) transfers are supported for external accesses.
- The DMA does not support transfers from peripherals to external memory.
- The DMA does not support transfers from external memory to the peripherals.
- The DMA does not support external to external transfers.
- The DMA does not support synchronized external transfers.

The HM bit in the ST1 register indicates whether the processor continues internal execution when acknowledging an active HOLD signal.

- HM = 0, the processor continues execution from internal program memory but places its external interface in the high impedance state.
- HM = 1, the processor halts internal execution.

To ensure that proper arbitration occurs, the HM bit should be set to 0 in the memory-mapped ST1 register. If the HM is set to 1 the processor will halt during DMA external transfers.

### 3.3.5.2 DMA External Transfer

Unlike the 5410, the 5409 DMA mode control register (DMMCR<sub>x</sub>) has two additional bits; DLAXS (DMMCR<sub>n</sub>[5]) and SLAXS (DMMCR<sub>n</sub>[11]). These new bits specify the on/off-chip memory for the source and destination of the program/data/IO spaces.

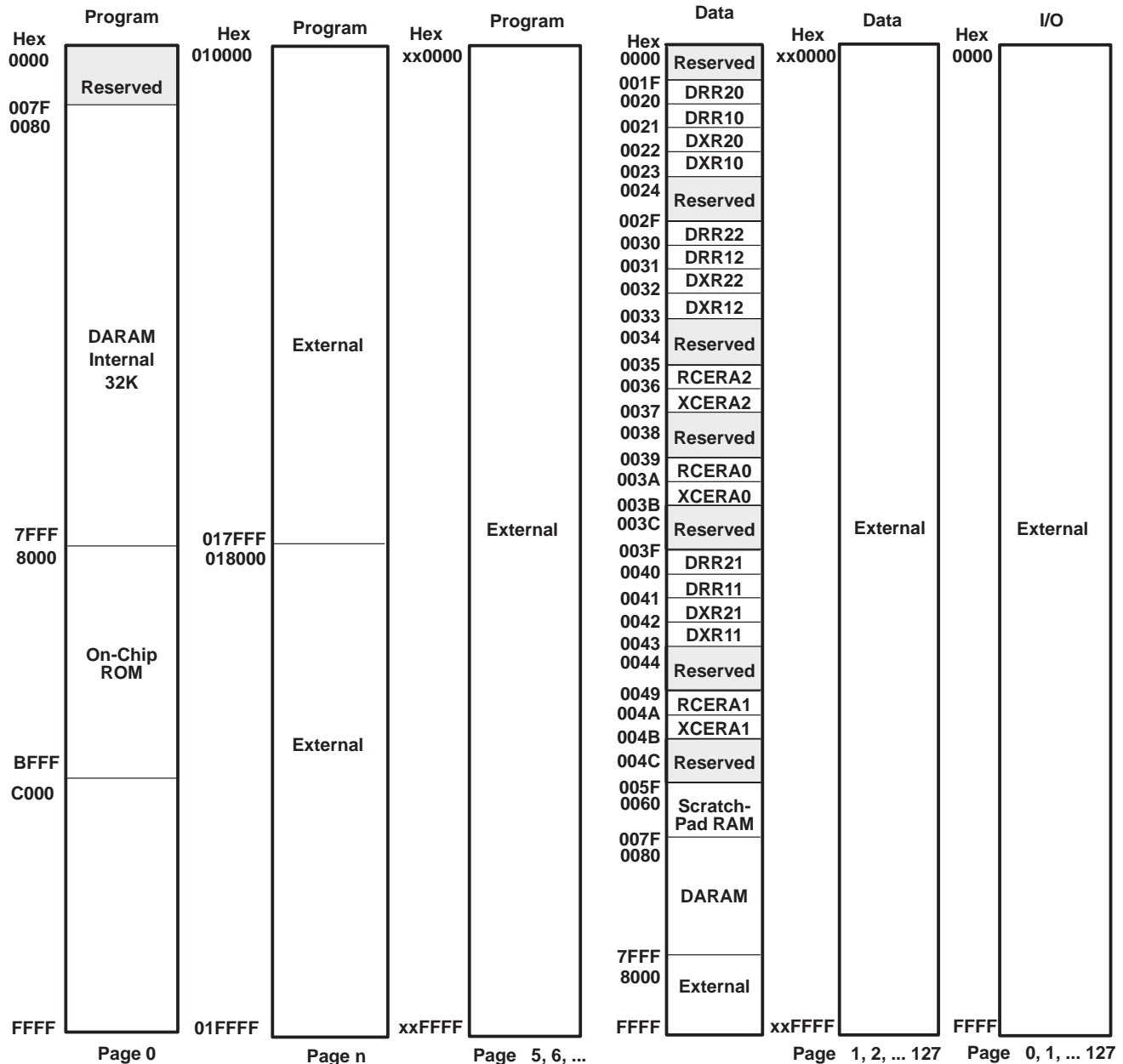
- When DLAXS is set to 0 (default), the DMA does not perform an external access for the destination. When DLAXS is set to 1, the DMA performs an external access to the destination location.
- When SLAXS is set to 0 (default), the DMA does not perform an external access for the source. When DLAXS is set to 1, the DMA performs an external access from the source location.

Two new registers are added to the 5409 DMA to support DMA accesses to/from DMA extended data memory, page 1 to page 127.

- The DMA extended source data page register (XSRCDP[6:0]) is located at subbank address 028h.
- The DMA extended destination data page register (XDSTDP[6:0]) is located at subbank address 029h.

### 3.3.5.3 DMA Memory Map

The DMA memory map, as shown in Figure 3–10, allows DMA transfers to be unaffected by the status of the  $\overline{MP/MC}$ , DROM, and OVLY bits.



NOTE: n = 1, 2, 3, or 4

Figure 3-10. TMS320VC5409 DMA Memory Map

### 3.3.5.4 DMA Priority Level

Each DMA channel can be independently assigned high priority or low priority relative to each other. Multiple DMA channels that are assigned to the same priority level are handled in a round-robin manner.

### 3.3.5.5 DMA Source/Destination Address Modification

The DMA provides flexible address-indexing modes for easy implementation of data management schemes such as autobuffering and circular buffers. Source and destination addresses can be indexed separately and can be post-incremented, post-decremented, or post-incremented with a specified index offset.



### 3.3.5.6 DMA in Autoinitialization Mode

The DMA can automatically reinitialize itself after completion of a block transfer. Some of the DMA registers can be preloaded for the next block transfer through the DMA global reload registers (DMGSA, DMGDA, and DMGCR). Autoinitialization allows:

- Continuous operation: Normally, the CPU would have to reinitialize the DMA immediately after the completion of the current block transfer; but with the global reload registers, it can reinitialize these values for the next block transfer any time after the current block transfer begins.
- Repetitive operation: The CPU does not preload the global reload register with new values for each block transfer but only loads them on the first block transfer.

### 3.3.5.7 DMA Transfer Counting

The DMA channel element count register (DMCTR<sub>x</sub>) and the frame count register (DMFRC<sub>x</sub>) contain bit fields that represent the number of frames and the number of elements per frame to be transferred.

- Frame count. This 8-bit value defines the total number of frames in the block transfer. The maximum number of frames per block transfer is 128 (FRAME COUNT= 0ffh). The counter is decremented upon the last read transfer in a frame transfer. Once the last frame is transferred, the selected 8-bit counter is reloaded with the DMA global frame reload register (DMGFR) if the AUTOINIT bit is set to 1. A frame count of 0 (default value) means the block transfer contains a single frame.
- Element count. This 16-bit value defines the number of elements per frame. This counter is decremented after the read transfer of each element. The maximum number of elements per frame is 65536 (DMCTR<sub>n</sub> = 0FFFFh). In autoinitialization mode, once the last frame is transferred, the counter is reloaded with the DMA global count reload register (DMGCR).

### 3.3.5.8 DMA Transfers in Double-word Mode (Internal Only)

Double-word mode allows the DMA to transfer 32-bit words in any index mode. In double-word mode, two consecutive 16-bit transfers are initiated and the source and destination addresses are automatically updated following each transfer. In this mode, each 32-bit word is considered to be one element.

### 3.3.5.9 DMA Channel Index Registers

The particular DMA channel index register is selected by way of the SIND and DIND field in the DMA mode control register (DMMCR<sub>x</sub>). Unlike basic address adjustment, in conjunction with the frame index DMFRI0 and DMFRI1, the DMA allows different adjustment amounts depending on whether or not the element transfer is the last in the current frame. The normal adjustment value (element index) is contained in the element index registers DMIDX0 and DMIDX1. The adjustment value (frame index) for the end of the frame is determined by the selected DMA frame index register (either DMFRI0 or DMFRI1).

The element index and the frame index affect address adjustment as follows:

- Element index: For all except the last transfer in the frame, the element index determines the amount to be added to the DMA channel for the source/destination address register (DMSRC<sub>x</sub>/DMDST<sub>x</sub>) as selected by the SIND/DIND bits.
- Frame index: If the transfer is the last in a frame, the frame index is used for address adjustment as selected by the SIND/DIND bits. This occurs in both single-frame and multi-frame transfer.

### 3.3.5.10 DMA Interrupts

The ability of the DMA to interrupt the CPU based on the status of the data transfer is configurable and is determined by the IMOD and DINM bits in the DMA channel mode control register (DMMCRn). The available modes are shown in Table 3–12.

**Table 3–12. DMA Interrupts**

MODE	DINM	IMOD	INTERRUPT
ABU (non-decrement)	1	0	At full buffer only
ABU (non-decrement)	1	1	At half buffer and full buffer
Multi-Frame	1	0	At block-transfer complete (DMCTRn = DMSEFCn[7:0] = 0)
Multi-Frame	1	1	At end of frame and end of block (DMCTRn = 0)
Either	0	X	No interrupt generated
Either	0	X	No interrupt generated

#### 3.3.5.10.1 DMA Controller Synchronization Events

The internal transfers associated with each DMA channel can be synchronized to one of several events. The DSYN bit field of the DMSEFCn register selects the synchronization event for a channel. The list of possible events and the DSYN values are shown in Table 3–13.

**Table 3–13. DMA Synchronization Events**

DSYN VALUE	DMA SYNCHRONIZATION EVENT
0000b	No synchronization used
0001b	McBSP0 receive event
0010b	McBSP0 transmit event
0011b	McBSP2 receive event
0100b	McBSP2 transmit event
0101b	McBSP1 receive event
0110b	McBSP1 transmit event
0111b	Reserved
1000b	Reserved
1001b	Reserved
1010b	Reserved
1011b	Reserved
1100b	Reserved
1101b	Timer interrupt event
1110b	External interrupt 3
1111b	Reserved

### 3.3.5.10.2 DMA Channel Interrupt Selection

The DMA controller can generate a CPU interrupt for each of the six channels. However, due to a limit on the number of internal CPU interrupt inputs, channels 0, 1, 2, and 3 are multiplexed with other interrupt sources. DMA channels 0, 1, 2, and 3 share an interrupt line with the receive and transmit portions of the McBSP. When the 5409 is reset, the interrupts from these three DMA channels are deselected. The INTSEL bit field in the DMPREC register can be used to select these interrupts, as shown in Table 3–14.

**Table 3–14. DMA Channel Interrupt Selection**

INTSEL Value	IMR/IFR[6]	IMR/IFR[7]	IMR/IFR[10]	IMR/IFR[11]
00b (reset)	BRINT2	BXINT2	BRINT1	BXINT1
01b	BRINT2	BXINT2	DMAC2	DMAC3
10b	DMAC0	DMAC1	DMAC2	DMAC3
11b	Reserved			

### 3.3.5.11 DMA Subbank Addressed Registers

The direct memory access (DMA) controller has several control registers associated with it. The main control register (DMPREC) is a standard memory mapped register. However, the other registers are accessed using the subbank addressing scheme. This allows a set, or subbank of registers to be accessed through a single memory location. The DMA subbank address (DMSA) register is used as a pointer to select a particular register within the subbank, while the DMA subbank data (DMSDN) register or the DMA subbank data register with autoincrement (DMSDI) is used to access (read or write) the selected register.

When the DMSDI register is used to access the subbank, the subbank address is automatically postincremented so that a subsequent access affects the next register within the subbank. This autoincrement feature is intended for efficient, successive accesses to several control registers. If the auto-increment feature is not required, the DMSDN register should be used to access the subbank. Table 3–15 shows the DMA controller subbank addressed registers and their corresponding subaddresses.

**Table 3–15. DMA Subbank Addressed Registers**

DMA		SUB ADDRESS	DESCRIPTION
NAME	ADDRESS		
DMSRC0	56h/57h	00h	DMA channel 0 source address register
DMDST0	56h/57h	01h	DMA channel 0 destination address register
DMCTR0	56h/57h	02h	DMA channel 0 element count register
DMSFC0	56h/57h	03h	DMA channel 0 sync select and frame count register
DMMCR0	56h/57h	04h	DMA channel 0 transfer mode control register
DMSRC1	56h/57h	05h	DMA channel 1 source address register
DMDST1	56h/57h	06h	DMA channel 1 destination address register
DMCTR1	56h/57h	07h	DMA channel 1 element count register
DMSFC1	56h/57h	08h	DMA channel 1 sync select and frame count register
DMMCR1	56h/57h	09h	DMA channel 1 transfer mode control register
DMSRC2	56h/57h	0Ah	DMA channel 2 source address register
DMDST2	56h/57h	0Bh	DMA channel 2 destination address register
DMCTR2	56h/57h	0Ch	DMA channel 2 element count register
DMSFC2	56h/57h	0Dh	DMA channel 2 sync select and frame count register
DMMCR2	56h/57h	0Eh	DMA channel 2 transfer mode control register
DMSRC3	56h/57h	0Fh	DMA channel 3 source address register
DMDST3	56h/57h	10h	DMA channel 3 destination address register
DMCTR3	56h/57h	11h	DMA channel 3 element count register
DMSFC3	56h/57h	12h	DMA channel 3 sync select and frame count register

**Table 3–15. DMA Subbank Addressed Registers (Continued)**

DMA		SUB ADDRESS	DESCRIPTION
NAME	ADDRESS		
DMMCR3	56h/57h	13h	DMA channel 3 transfer mode control register
DMSRC4	56h/57h	14h	DMA channel 4 source address register
DMDST4	56h/57h	15h	DMA channel 4 destination address register
DMCTR4	56h/57h	16h	DMA channel 4 element count register
DMSFC4	56h/57h	17h	DMA channel 4 sync select and frame count register
DMMCR4	56h/57h	18h	DMA channel 4 transfer mode control register
DMSRC5	56h/57h	19h	DMA channel 5 source address register
DMDST5	56h/57h	1Ah	DMA channel 5 destination address register
DMCTR5	56h/57h	1Bh	DMA channel 5 element count register
DMSFC5	56h/57h	1Ch	DMA channel 5 sync select and frame count register
DMMCR5	56h/57h	1Dh	DMA channel 5 transfer mode control register
DMSRCP	56h/57h	1Eh	DMA source program page address (common channel)
DMDSTP	56h/57h	1Fh	DMA destination program page address (common channel)
DMIDX0	56h/57h	20h	DMA element index address register 0
DMIDX1	56h/57h	21h	DMA element index address register 1
DMFRI0	56h/57h	22h	DMA frame index register 0
DMFRI1	56h/57h	23h	DMA frame index register 1
DMGSA	56h/57h	24h	DMA global source address reload register
DMGDA	56h/57h	25h	DMA global destination address reload register
DMGCR	56h/57h	26h	DMA global count reload register
DMGFR	56h/57h	27h	DMA global frame count reload register
XSRCDP	56h/57h	28h	DMA global extended source register
XDSTDP	56h/57h	29h	DMA global extended destination register

### 3.3.6 Peripheral Memory-Mapped Registers

The device provides a set of memory-mapped registers associated with peripherals. Table 3–4 gives a list of CPU memory-mapped registers (MMRs) available on 5409. Table 3–16 shows additional peripheral MMRs associated with the 5409.

**Table 3–16. Peripheral Memory-Mapped Registers**

NAME	ADDRESS	DESCRIPTION	TYPE
DRR20	20h	Data receive register 2	McBSP #0
DRR10	21h	Data receive register 1	McBSP #0
DXR20	22h	Data transmit register 2	McBSP #0
DXR10	23h	Data transmit register 1	McBSP #0
TIM	24h	Timer register	Timer
PRD	25h	Timer period counter	Timer
TCR	26h	Timer control register	Timer
–	27h	Reserved	
SWWSR	28h	Software wait-state register	External Bus
BSCR	29h	Bank-switching control register	External Bus
–	2Ah	Reserved	
SWCR	2Bh	Software wait-state control register	External Bus
HPIC	2Ch	HPI control register	HPI
–	2Dh–2Fh	Reserved	
DRR22	30h	Data receive register 2	McBSP #2
DRR12	31h	Data receive register 1	McBSP #2
DXR22	32h	Data transmit register 2	McBSP #2
DXR12	33h	Data transmit register 2	McBSP #2
SPSA2	34h	McBSP2 subbank address register	McBSP #2
SPSD2	35h	McBSP2 subbank data register	McBSP #2
–	36–37h	Reserved	
SPSA0	38h	McBSP0 subbank address register	McBSP #0
SPCD0	39h	McBSP0 subbank data register	McBSP #0
–	3Ah–3Bh	Reserved	
GPIOCR	3C	General-purpose I/O pins control register	GPIO
GPIOSR	3D	General-purpose I/O pins status register	GPIO
–	3E–3F	Reserved	
DRR21	40h	Data receive register 1	McBSP #1
DRR11	41h	Data receive register 2	McBSP #1
DXR21	42h	Data transmit register 1	McBSP #1
DXR11	43h	Data transmit register 2	McBSP #1
–	44h–47h	Reserved	
SPSA1	48h	McBSP1 subbank address register	McBSP #1
SPCD1	49h	McBSP1 subbank data register	McBSP #1
–	4Ah–53h	Reserved	
DMPREC	54h	DMA channel priority and enable control register	DMA
DMSA	55h	DMA subbank address register	DMA
DMSDI	56h	DMA subbank data register with autoincrement	DMA
DMSDN	57h	DMA subbank data register	DMA
CLKMD	58h	Clock mode register	PLL
–	59h–5Fh	Reserved	

### 3.4 Interrupts

Vector-relative locations and priorities for all internal and external interrupts are shown in Table 3–17.

**Table 3–17. Interrupt Locations and Priorities**

NAME	TRAP/INTR NUMBER (K)	LOCATION		PRIORITY	FUNCTION
		DECIMAL	HEX		
$\overline{RS}$ , SINTR	0	0	00	1	Reset (hardware and software reset)
$\overline{NMI}$ , SINT16	1	4	04	2	Nonmaskable interrupt
SINT17	2	8	08	—	Software interrupt #17
SINT18	3	12	0C	—	Software interrupt #18
SINT19	4	16	10	—	Software interrupt #19
SINT20	5	20	14	—	Software interrupt #20
SINT21	6	24	18	—	Software interrupt #21
SINT22	7	28	1C	—	Software interrupt #22
SINT23	8	32	20	—	Software interrupt #23
SINT24	9	36	24	—	Software interrupt #24
SINT25	10	40	28	—	Software interrupt #25
SINT26	11	44	2C	—	Software interrupt #26
SINT27	12	48	30	—	Software interrupt #27
SINT28	13	52	34	—	Software interrupt #28
SINT29	14	56	38	—	Software interrupt #29
SINT30	15	60	3C	—	Software interrupt #30
$\overline{INT0}$ , SINT0	16	64	40	3	External user interrupt #0
$\overline{INT1}$ , SINT1	17	68	44	4	External user interrupt #1
$\overline{INT2}$ , SINT2	18	72	48	5	External user interrupt #2
TINT, SINT3	19	76	4C	6	Timer interrupt
BRINT0, SINT4	20	80	50	7	McBSP #0 receive interrupt (default)
BXINT0, SINT5	21	84	54	8	McBSP #0 transmit interrupt (default)
BRINT2, SINT7, DMAC0	22	88	58	9	McBSP #2 receive interrupt (default)
BXINT2, SINT6, DMAC1	23	92	5C	10	McBSP #2 transmit interrupt (default)
$\overline{INT3}$ , SINT8	24	96	60	11	External user interrupt #3
HINT, SINT9	25	100	64	12	HPI interrupt
BRINT1, SINT10, DMAC2	26	104	68	13	McBSP #1 receive interrupt (default)
BXINT1, SINT11, DMAC3	27	108	6C	14	McBSP #1 transmit interrupt (default)
DMAC4,SINT12	28	112	70	15	DMA channel 4 interrupt (default)
DMAC5,SINT13	29	116	74	16	DMA channel 5 interrupt (default)
Reserved	30–31	120–127	78–7F	—	Reserved

The bits of the interrupt flag register (IFR) and interrupt mask register (IMR) are arranged as shown in Figure 3–11. The function of each bit is described in Table 3–18.

15	14	13	12	11	10	9	8
Reserved	DMAC5	DMAC4	BXINT1/ DMAC3	BRINT1/ DMAC2	HINT	INT3	
7	6	5	4	3	2	1	0
BXINT2/ DMAC1	BRINT2/ DMAC0	BXINT0	BRINT0	TINT	INT2	INT1	INT0

**LEGEND:** R = Read, W = Write, *n* = value present after reset

**Figure 3–11. IFR and IMR Registers**

**Table 3–18. IFR and IMR Register Bit Fields**

BIT		FUNCTION
NUMBER	NAME	
15–14	–	Reserved for future expansion
13	DMAC5	DMA channel 5 interrupt flag/mask bit
12	DMAC4	DMA channel 4 interrupt flag/mask bit
11	BXINT1/DMAC3	McBSP1 transmit interrupt flag/mask bit
10	BRINT1/DMAC2	McBSP1 receive interrupt flag/mask bit
9	HINT	Host to 54x interrupt flag/mask
8	INT3	External interrupt 3 flag/mask
7	BXINT2/DMAC1	McBSP2 transmit interrupt flag/mask bit
6	BRINT2/DMAC0	McBSP2 receive interrupt flag/mask bit
5	BXINT0	McBSP0 transmit interrupt flag/mask bit
4	BRINT0	McBSP0 receive interrupt flag/mask bit
3	TINT	Timer interrupt flag/mask bit
2	INT2	External interrupt 2 flag/mask bit
1	INT1	External interrupt 1 flag/mask bit
0	INT0	External interrupt 0 flag/mask bit

## 4 Documentation Support

Extensive documentation supports all TMS320™ DSP family of devices from product announcement through applications development. The following types of documentation are available to support the design and use of the C5000 family of DSPs:

- TMS320C54x™ *DSP Functional Overview* (literature number SPRU307)
- Device-specific data sheets (such as this document)
- Complete User Guides
- Development-support tools
- Hardware and software application reports

The five-volume *TMS320C54x DSP Reference Set* (literature number SPRU210) consists of:

- *Volume 1: CPU and Peripherals* (literature number SPRU131)
- *Volume 2: Mnemonic Instruction Set* (literature number SPRU172)
- *Volume 3: Algebraic Instruction Set* (literature number SPRU179)
- *Volume 4: Applications Guide* (literature number SPRU173)
- *Volume 5: Enhanced Peripherals* (literature number SPRU302)

The reference set describes in detail the TMS320C54x products currently available, and the hardware and software applications, including algorithms, for fixed-point TMS320 devices.

A series of DSP textbooks is published by Prentice-Hall and John Wiley & Sons to support digital signal processing research and education. The TMS320 newsletter, *Details on Signal Processing*, is published quarterly and distributed to update TMS320 customers on product information.

Information regarding TI™ DSP products is also available on the Worldwide Web at <http://www.ti.com> uniform resource locator (URL).



## 4.1 Device and Development Tool Support Nomenclature

To designate the stages in the product development cycle, TI assigns prefixes to the part numbers of all TMS320 DSP devices and support tools. Each TMS320 DSP commercial family member has one of three prefixes: TMX, TMP, or TMS. Texas Instruments recommends two of three possible prefix designators for its support tools: TMDX and TMDS. These prefixes represent evolutionary stages of product development from engineering prototypes (TMX/TMDX) through fully qualified production devices/tools (TMS/TMDS).

Device development evolutionary flow:

- TMX** Experimental device that is not necessarily representative of the final device's electrical specifications
- TMP** Final silicon die that conforms to the device's electrical specifications but has not completed quality and reliability verification
- TMS** Fully-qualified production device

Support tool development evolutionary flow:

- TMDX** Development support product that has not yet completed Texas Instruments internal qualification testing.
- TMDS** Fully qualified development support product

TMX and TMP devices and TMDX development-support tools are shipped with appropriate disclaimers describing their limitations and intended uses. Experimental devices (TMX) may not be representative of a final product and Texas Instruments reserves the right to change or discontinue these products without notice.

TMS devices and TMDS development-support tools have been characterized fully, and the quality and reliability of the device have been demonstrated fully. TI's standard warranty applies.

Predictions show that prototype devices (TMX or TMP) have a greater failure rate than the standard production devices. Texas Instruments recommends that these devices not be used in any production system because their expected end-use failure rate still is undefined. Only qualified production devices are to be used.

## 5 Electrical Specifications

### 5.1 Absolute Maximum Ratings

Supply voltage I/O range, $DV_{DD}^{\dagger}$	-0.3 V to 4.0 V
Supply voltage core range, $CV_{DD}^{\dagger}$	-0.3 V to 2.4 V
Input voltage range, $V_I$	-0.3 V to 4.5 V
Output voltage range, $V_O$	-0.3 V to 4.5 V
Operating case temperature range, $T_C$	-40°C to 100°C
Storage temperature range, $T_{stg}$	-55°C to 150°C

NOTE: Stresses beyond those listed under “absolute maximum ratings” may cause permanent damage to the device. These are stress ratings only, and functional operation of the device at these or any other conditions beyond those indicated under “recommended operating conditions” is not implied. Exposure to absolute-maximum-rated conditions for extended periods may affect device reliability.

$\dagger$  All voltage values are with respect to  $V_{SS}$ .

### 5.2 Recommended Operating Conditions

		MIN	NOM	MAX	UNIT	
$DV_{DD}$	Device supply voltage, I/O $\ddagger$	3	3.3	3.6	V	
$CV_{DD}$	Device supply voltage, core $\ddagger$	1.71	1.8	1.98	V	
$V_{SS}$	Supply voltage, GND	0			V	
$V_{IH}$	High-level input voltage, I/O	RS, INTn, NMI, BIO, BCLKR0, BCLKR1, BCLKR2, BCLKX0, BCLKX1, BCLKX2, HAS, HCS, HDS1, HDS2, TCK, CLKMDn, $DV_{DD} = 3.3 \pm 0.3$ V		2.2	$DV_{DD} + 0.3$	V
		TRST		2.5	$DV_{DD} + 0.3$	
		X2/CLKIN		1.4	$CV_{DD} + 0.3$	
		All other inputs		2.0	$DV_{DD} + 0.3$	
$V_{IL}$	Low-level input voltage	RS, INTn, NMI, X2/CLKIN, BIO, BCLKR0, BCLKR1, BCLKR2, BCLKX0, BCLKX1, BCLKX2, HAS, HCS, HDS1, HDS2, TCK, CLKMDn, $DV_{DD} = 3.3 \pm 0.3$ V		-0.3	0.6	V
		All other inputs		-0.3	0.8	
$I_{OH}$	High-level output current				-300	$\mu$ A
$I_{OL}$	Low-level output current				1.5	mA
$T_C$	Operating case temperature	-40			100	°C

$\ddagger$  Texas Instrument DSPs do not require specific power sequencing between the core supply and the I/O supply. However, systems should be designed to ensure that neither supply is powered up for extended periods of time if the other supply is below the proper operating voltage. Excessive exposure to these conditions can adversely affect the long-term reliability of the devices. System-level concerns such as bus contention may require supply sequencing to be implemented. In this case, the core supply should be powered up at the same time as or prior to the I/O buffers, and then powered down after the I/O buffers.

### 5.3 Electrical Characteristics

PARAMETER		TEST CONDITIONS	MIN	TYP†	MAX	UNIT	
$V_{OH}$	High-level output voltage	$I_{OH} = \text{MAX}$	2.4			V	
$V_{OL}$	Low-level output voltage	$I_{OL} = \text{MAX}$			0.4	V	
$I_{IZ}$	Input current for outputs in high impedance	D[15:0], HD[7:0], A[15:0]	Bus holders enabled, $DV_{DD} = \text{MAX}$ , $V_I = V_{SS}$ to $DV_{DD}$		-200	200	$\mu\text{A}$
		All other inputs	$DV_{DD} = \text{MAX}$ , $V_O = V_{SS}$ to $DV_{DD}$		-5	5	
$I_I$	Input current	X2/CLKIN	$(V_I = V_{SS}$ to $DV_{DD})$	-40	40	$\mu\text{A}$	
		$\overline{\text{TRST}}$		With internal pulldown	-5		200
		HPIENA, HPI16		With internal pulldown	-5		200
		TMS, TCK, TDI, HPI‡		With internal pullups, HPIENA = 0	-200		5
		All other input-only pins			-5		5
$I_{DDC}$	Supply current, core CPU	$CV_{DD} = 1.8 \text{ V}$ , $f_{\text{clock}} = 100 \text{ MHz}$ , § $T_C = 25^\circ\text{C}$ ¶		37		mA	
$I_{DDP}$	Supply current, pins	$DV_{DD} = 3.3 \text{ V}$ , $f_{\text{clock}} = 100 \text{ MHz}$ , § $T_C = 25^\circ\text{C}$ #		45		mA	
$I_{DD}$	Supply current, standby	IDLE2	PLL $\times 2$ mode, 50 MHz input		2	mA	
		IDLE3	Divide-by-two mode, CLKIN stopped		20	$\mu\text{A}$	
$C_i$	Input capacitance			5		pF	
$C_o$	Output capacitance			5		pF	

† All values are typical unless otherwise specified.

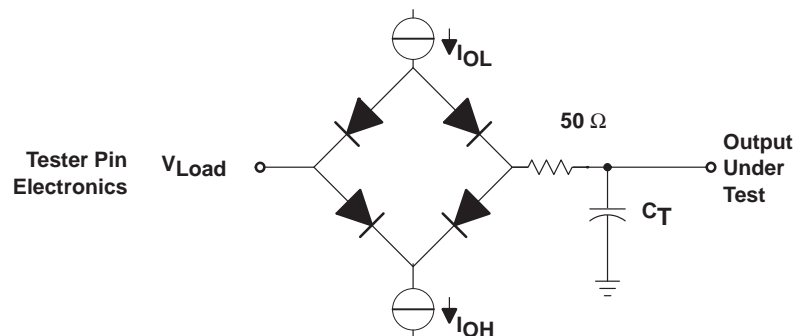
‡ HPI input signals except for HPIENA.

§ Clock mode: PLL  $\times 1$  with external source

¶ This value represents the current consumption of the CPU, on-chip memory, and on-chip peripherals. Conditions include: program execution from on-chip RAM, with 50% usage of MAC and 50% usage of NOP instructions. Actual operating current varies with program being executed.

# This value was obtained using the following conditions: external memory writes at a rate of 20 million writes per second, CLKOFF=0, full-duplex operation of all three McBSPs at a rate of 10 million bits per second each, and 15-pF loads on all outputs. For more details on how this calculation is performed, refer to the *Calculation of TMS320LC54x Power Dissipation Application Report* (literature number SPRA164).

The following load circuit in Figure 5–1 was used on all outputs pins and I/O pins in input mode. All timing measurements in this data sheet were measured from the 5409 connection to the following load circuit.



Where:  $I_{OL} = 1.5 \text{ mA}$  (all outputs)  
 $I_{OH} = 300 \mu\text{A}$  (all outputs)  
 $V_{Load} = 1.5 \text{ V}$   
 $C_T = 40\text{-pF}$  typical load circuit capacitance

Figure 5–1. 3.3-V Test Load Circuit

## 5.4 Internal Oscillator with External Crystal

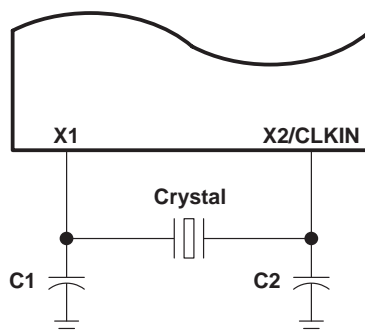
The internal oscillator is enabled by connecting a crystal across X1 and X2/CLKIN. The frequency of CLKOUT is a multiple of the oscillator frequency. The multiply ratio is determined by the bit settings in the CLKMD register. The crystal should be in fundamental-mode operation, and parallel resonant, with an effective series resistance of 30  $\Omega$  and power dissipation of 1 mW.

The connection of the required circuit, consisting of the crystal and two load capacitors, is shown in Figure 5–2. The load capacitors,  $C_1$  and  $C_2$ , should be chosen such that the equation below is satisfied.  $C_L$  in the equation is the load specified for the crystal.

$$C_L = \frac{C_1 C_2}{(C_1 + C_2)}$$

**Table 5–1. Recommended Operating Conditions of Internal Oscillator With External Crystal**

	MIN	MAX	UNIT
$f_{\text{clock}}$ Input clock frequency	10	20	MHz



**Figure 5–2. Internal Oscillator With External Crystal**

## 5.5 Divide-By-Two/Divide-By-Four Clock Option (PLL Disabled)

The frequency of the reference clock provided at the X2/CLKIN pin can be divided by a factor of two or four to generate the internal machine cycle. The selection of the clock mode is described in the clock generator section.

When an external clock source is used, the frequency injected must conform to specifications listed in the timing requirements table. Table 5–2 and Table 5–3 assumes testing over recommended operating conditions and  $H = 0.5t_{c(CO)}$  (see Figure 5–3).

**Table 5–2. Divide-By-Two/Divide-By-Four Clock Option (PLL Disabled) Timing Requirements**

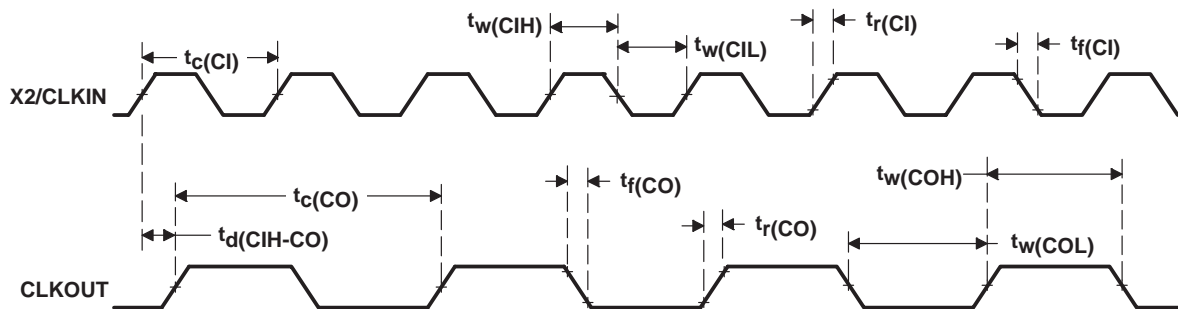
	MIN	MAX	UNIT
$t_{c(CI)}$ Cycle time, X2/CLKIN	20	†	ns
$t_f(CI)$ Fall time, X2/CLKIN		8	ns
$t_r(CI)$ Rise time, X2/CLKIN		8	ns
$t_w(CIL)$ Pulse duration, X2/CLKIN low	5		ns
$t_w(CIH)$ Pulse duration, X2/CLKIN high	5		ns

† This device utilizes a fully static design and therefore can operate with  $t_{c(CI)}$  approaching  $\infty$ . The device is characterized at frequencies approaching 0 Hz.

**Table 5–3. Divide-By-Two/Divide-By-Four Clock Option (PLL Disabled) Switching Characteristics**

PARAMETER	MIN	TYP	MAX	UNIT
$t_{c(CO)}$ Cycle time, CLKOUT	40	$2t_{c(CI)}$	†	ns
$t_d(CIH-CO)$ Delay time, X2/CLKIN high to CLKOUT high/low	4	10	17	ns
$t_f(CO)$ Fall time, CLKOUT		2		ns
$t_r(CO)$ Rise time, CLKOUT		2		ns
$t_w(COL)$ Pulse duration, CLKOUT low	H–2	H–1	H	ns
$t_w(COH)$ Pulse duration, CLKOUT high	H–2	H–1	H	ns

† This device utilizes a fully static design and therefore can operate with  $t_{c(CI)}$  approaching  $\infty$ . The device is characterized at frequencies approaching 0 Hz.



**Figure 5–3. External Divide-by-Two Clock Timing**

## 5.6 Multiply-By-N Clock Option (PLL Enabled)

The frequency of the reference clock provided at the X2/CLKIN pin can be multiplied by a factor of N to generate the internal machine cycle. The selection of the clock mode and the value of N is described in the clock generator section.

When an external clock source is used, the external frequency injected must conform to specifications listed in the timing requirements table. Table 5–4 and Table 5–5 assumes testing over recommended operating conditions and  $H = 0.5t_{c(CO)}$  (see Figure 5–4).

**Table 5–4. Multiply-By-N Clock Option (PLL Enabled) Timing Requirements**

		MIN	MAX	UNIT
$t_{c(CI)}$ Cycle time, X2/CLKIN	Integer PLL multiplier N (N = 1–15)	20 <sup>†</sup>	200	ns
	PLL multiplier N = x.5	20 <sup>‡</sup>	100	
	PLL multiplier N = x.25, x.75	20 <sup>‡</sup>	50	
$t_f(CI)$ Fall time, X2/CLKIN			8	ns
$t_r(CI)$ Rise time, X2/CLKIN			8	ns
$t_w(CIL)$ Pulse duration, X2/CLKIN low		5		ns
$t_w(CIH)$ Pulse duration, X2/CLKIN high		5		ns

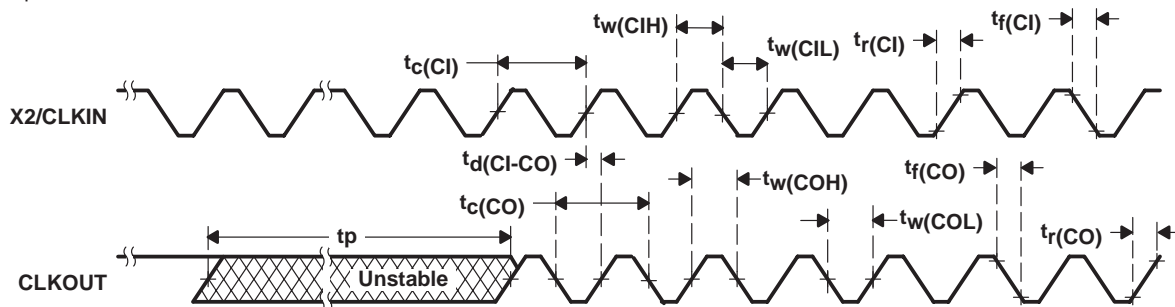
<sup>†</sup> N = Multiplication factor

<sup>‡</sup> The multiplication factor and minimum X2/CLKIN cycle time should be chosen such that the resulting CLKOUT cycle time is within the specified range ( $t_{c(CO)}$ )

**Table 5–5. Multiply-By-N Clock Option (PLL Enabled) Switching Characteristics**

PARAMETER	–80			–100			UNIT
	MIN	TYP	MAX	MIN	TYP	MAX	
$t_{c(CO)}$ Cycle time, CLKOUT	12.5	$t_{c(CI)}/N^{\dagger}$		10	$t_{c(CI)}/N^{\dagger}$		ns
$t_d(CI-CO)$ Delay time, X2/CLKIN high/low to CLKOUT high/low	4	10	17	4	10	17	ns
$t_f(CO)$ Fall time, CLKOUT		2			2		ns
$t_r(CO)$ Rise time, CLKOUT		2			2		ns
$t_w(COL)$ Pulse duration, CLKOUT low	H–3	H–1	H	H–2	H–1	H	ns
$t_w(COH)$ Pulse duration, CLKOUT high	H–3	H–1	H	H–2	H–1	H	ns
$t_p$ Transitory phase, PLL lock up time			30			30	μs

<sup>†</sup> N = Multiplication factor



**Figure 5–4. External Multiply-by-One Clock Timing**

## 5.7 Memory and Parallel I/O Interface Timing

### 5.7.1 Memory Read

External memory reads can be performed in consecutive or nonconsecutive mode under control of the **CONSEC** bit in the **BSCR**. Table 5–6 and Table 5–7 assume testing over recommended operating conditions with  $\overline{\text{MSTRB}} = 0$  and  $H = 0.5t_{c(\text{CO})}$  (see Figure 5–5).

**Table 5–6. Memory Read Timing Requirements**

		MIN	MAX	UNIT
$t_{a(\text{A})\text{M}}$	Access time, read data access from address valid		$2H-10$ <sup>¶</sup>	ns
$t_{a(\text{MSTRBL})}$	Access time, read data access from $\overline{\text{MSTRB}}$ low		$2H-10$ <sup>¶</sup>	ns
$t_{su(\text{D})\text{R}}$	Setup time, read data before CLKOUT low	8		ns
$t_{h(\text{D})\text{R}}$	Hold time, read data after CLKOUT low	0		ns
$t_{h(\text{A-D})\text{R}}$	Hold time, read data after address invalid	0		ns
$t_{h(\text{D})\text{MSTRBH}}$	Hold time, read data after $\overline{\text{MSTRB}}$ high	1		ns

<sup>†</sup> Address,  $\overline{\text{PS}}$ , and  $\overline{\text{DS}}$  timings are all included in timings referenced as address.

<sup>‡</sup> This access timing reflects a zero wait-state timing.

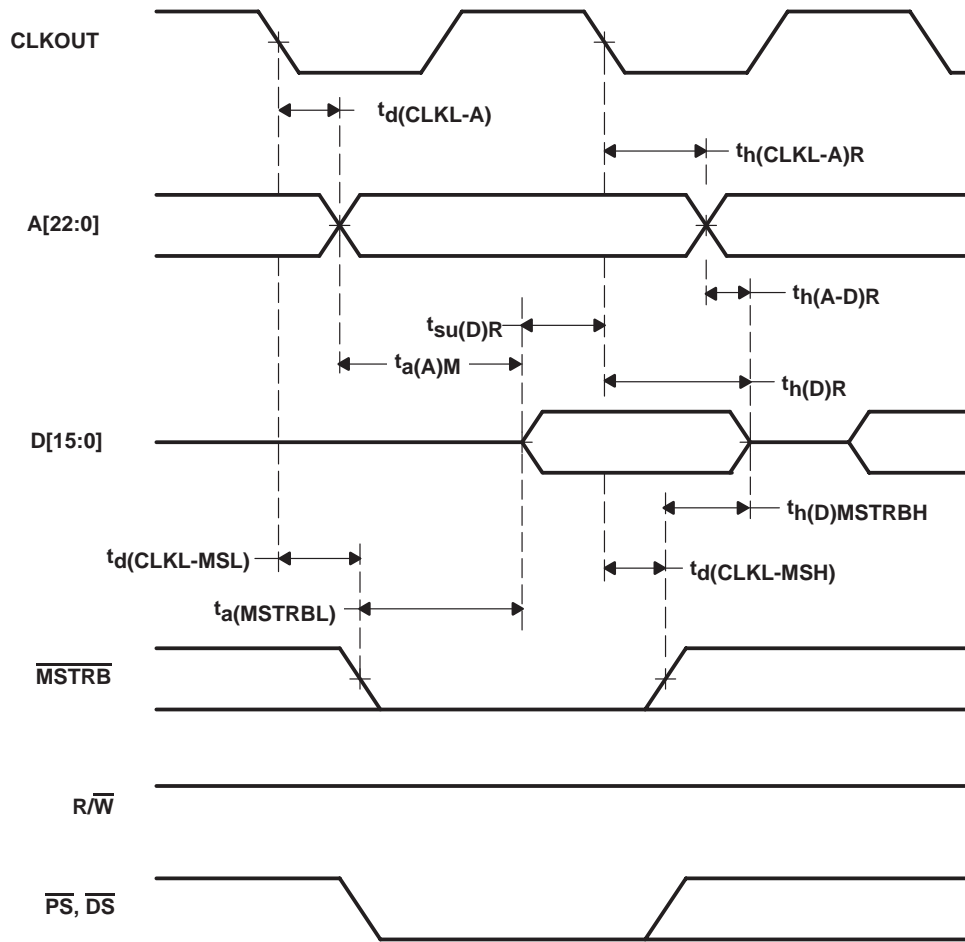
**Table 5–7. Memory Read Switching Characteristics**

PARAMETER		MIN	MAX	UNIT
$t_{d(\text{CLKL-A})}$	Delay time, CLKOUT low to address valid <sup>§</sup>	0	3	ns
$t_{d(\text{CLKH-A})}$	Delay time, CLKOUT high (transition) to address valid <sup>¶</sup>	0	3	ns
$t_{d(\text{CLKL-MSL})}$	Delay time, CLKOUT low to $\overline{\text{MSTRB}}$ low	0	3	ns
$t_{d(\text{CLKL-MSH})}$	Delay time, CLKOUT low to $\overline{\text{MSTRB}}$ high	0	3	ns
$t_{h(\text{CLKL-A})\text{R}}$	Hold time, address valid after CLKOUT low <sup>§</sup>	0	3	ns
$t_{h(\text{CLKH-A})\text{R}}$	Hold time, address valid after CLKOUT high <sup>¶</sup>	0	3	ns

<sup>†</sup> Address,  $\overline{\text{PS}}$ , and  $\overline{\text{DS}}$  timings are all included in timings referenced as address.

<sup>§</sup> In the case of a memory read preceded by a memory read

<sup>¶</sup> In the case of a memory read preceded by a memory write



NOTE A: A[22:16] apply to DMA accesses to extended I/O, DATA, PROGRAM memory. The CPU has access to **only** extended PROGRAM memory.

Figure 5-5. Memory Read



## 5.7.2 Memory Write

Table 5–8 assumes testing over recommended operating conditions with  $\overline{\text{MSTRB}} = 0$  and  $H = 0.5t_{c(\text{CO})}$  (see Figure 5–6).

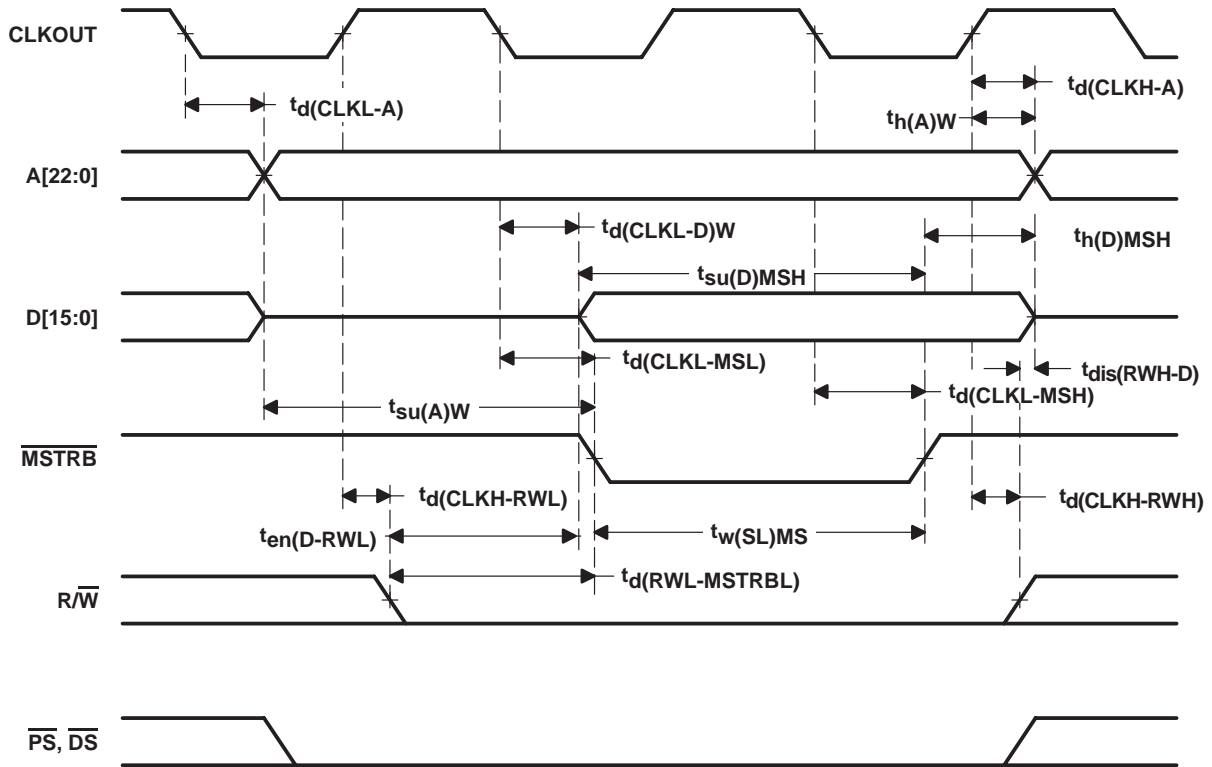
**Table 5–8. Memory Write Switching Characteristics†**

PARAMETER		MIN	MAX	UNIT
$t_{d(\text{CLKH-A})}$	Delay time, CLKOUT high to address valid‡	0	3	ns
$t_{d(\text{CLKL-A})}$	Delay time, CLKOUT low to address valid§	0	3	ns
$t_{d(\text{CLKL-MSL})}$	Delay time, CLKOUT low to $\overline{\text{MSTRB}}$ low	0	3	ns
$t_{d(\text{CLKL-D})W}$	Delay time, CLKOUT low to data valid	0	8	ns
$t_{d(\text{CLKL-MSH})}$	Delay time, CLKOUT low to $\overline{\text{MSTRB}}$ high	0	3	ns
$t_{d(\text{CLKH-RWL})}$	Delay time, CLKOUT high to $\overline{\text{R/W}}$ low	0	4	ns
$t_{d(\text{CLKH-RWH})}$	Delay time, CLKOUT high to $\overline{\text{R/W}}$ high	0	4	ns
$t_{d(\text{RWL-MSTRBL})}$	Delay time, $\overline{\text{R/W}}$ low to $\overline{\text{MSTRB}}$ low	H – 2	H + 1	ns
$t_{h(\text{A})W}$	Hold time, address valid after CLKOUT high‡	0	3	ns
$t_{h(\text{D})MSH}$	Hold time, write data valid after $\overline{\text{MSTRB}}$ high	H–3	H+6§	ns
$t_{w(\text{SL})MS}$	Pulse duration, $\overline{\text{MSTRB}}$ low	2H–2		ns
$t_{su(\text{A})W}$	Setup time, address valid before $\overline{\text{MSTRB}}$ low	2H–2		ns
$t_{su(\text{D})MSH}$	Setup time, write data valid before $\overline{\text{MSTRB}}$ high	2H–6	2H+6§	ns
$t_{en(\text{D-RWL})}$	Enable time, data bus driven after $\overline{\text{R/W}}$ low	H–5		ns
$t_{dis(\text{RWH-D})}$	Disable time, $\overline{\text{R/W}}$ high to data bus high impedance		0	ns

† Address,  $\overline{\text{PS}}$ , and  $\overline{\text{DS}}$  timings are all included in timings referenced as address.

‡ In the case of a memory write preceded by a memory write

§ In the case of a memory write preceded by an I/O cycle



NOTE A: A[22:16] apply to DMA accesses to extended I/O, DATA, PROGRAM memory. The CPU has access to **only** extended PROGRAM memory.

Figure 5–6. Memory Write

### 5.7.3 Parallel I/O Port Read

Table 5–9 and Table 5–10 assume testing over recommended operating conditions,  $\overline{\text{IOSTRB}} = 0$ , and  $H = 0.5t_{c(\text{CO})}$  (see Figure 5–7).

**Table 5–9. Parallel I/O Read Port Timing Requirements†**

		MIN	MAX	UNIT
$t_{a(\text{A})\text{IO}}$	Access time, read data access from address valid‡		3H–9	ns
$t_{a(\text{ISTRBL})\text{IO}}$	Access time, read data access from $\overline{\text{IOSTRB}}$ low‡		2H–8	ns
$t_{\text{su}(\text{D})\text{IOR}}$	Setup time, read data before CLKOUT high	8		ns
$t_{\text{h}(\text{D})\text{IOR}}$	Hold time, read data after CLKOUT high	0		ns
$t_{\text{h}(\text{ISTRBH-D})\text{R}}$	Hold time, read data after $\overline{\text{IOSTRB}}$ high	0		ns

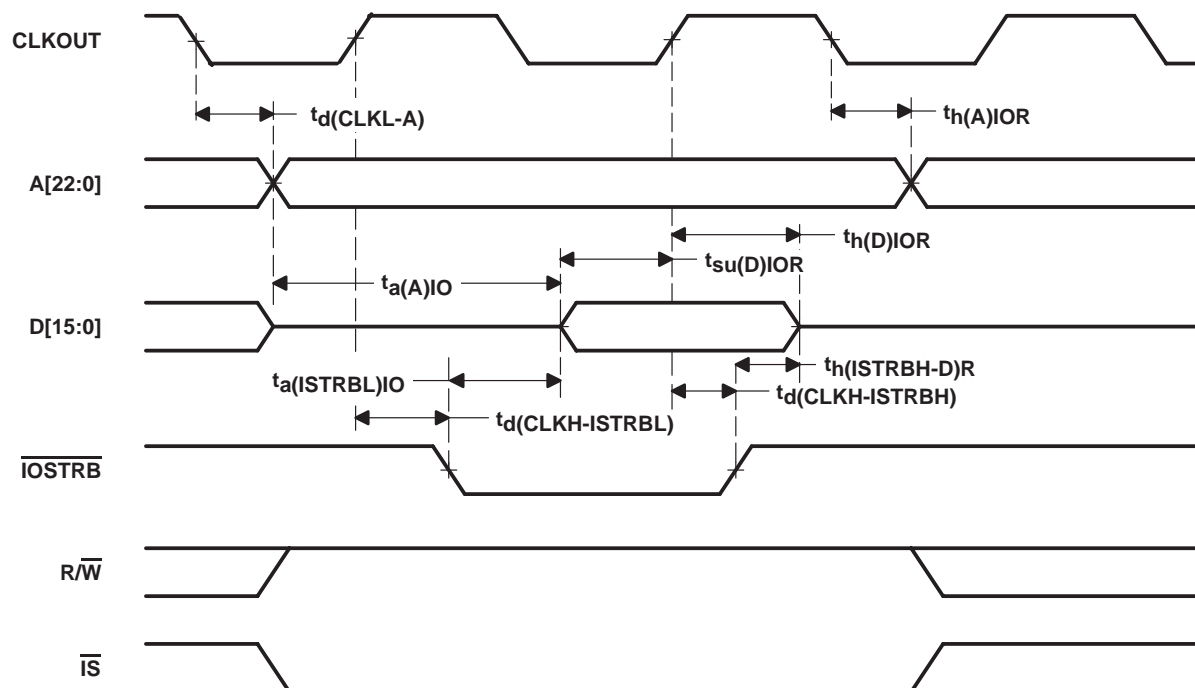
† Address and  $\overline{\text{IS}}$  timings are included in timings referenced as address.

‡ This access timing reflects a zero wait-state timing.

**Table 5–10. Parallel I/O Port Read Switching Characteristics†**

PARAMETER		MIN	MAX	UNIT
$t_{\text{d}(\text{CLKL-A})}$	Delay time, CLKOUT low to address valid	0	3	ns
$t_{\text{d}(\text{CLKH-ISTRBL})}$	Delay time, CLKOUT high to $\overline{\text{IOSTRB}}$ low	0	3	ns
$t_{\text{d}(\text{CLKH-ISTRBH})}$	Delay time, CLKOUT high to $\overline{\text{IOSTRB}}$ high	0	3	ns
$t_{\text{h}(\text{A})\text{IOR}}$	Hold time, address after CLKOUT low	0	3	ns

† Address and  $\overline{\text{IS}}$  timings are included in timings referenced as address.



NOTE A: A[22:16] apply to DMA accesses to extended I/O, DATA, PROGRAM memory. The CPU has access to **only** extended PROGRAM memory.

**Figure 5–7. Parallel I/O Port Read**

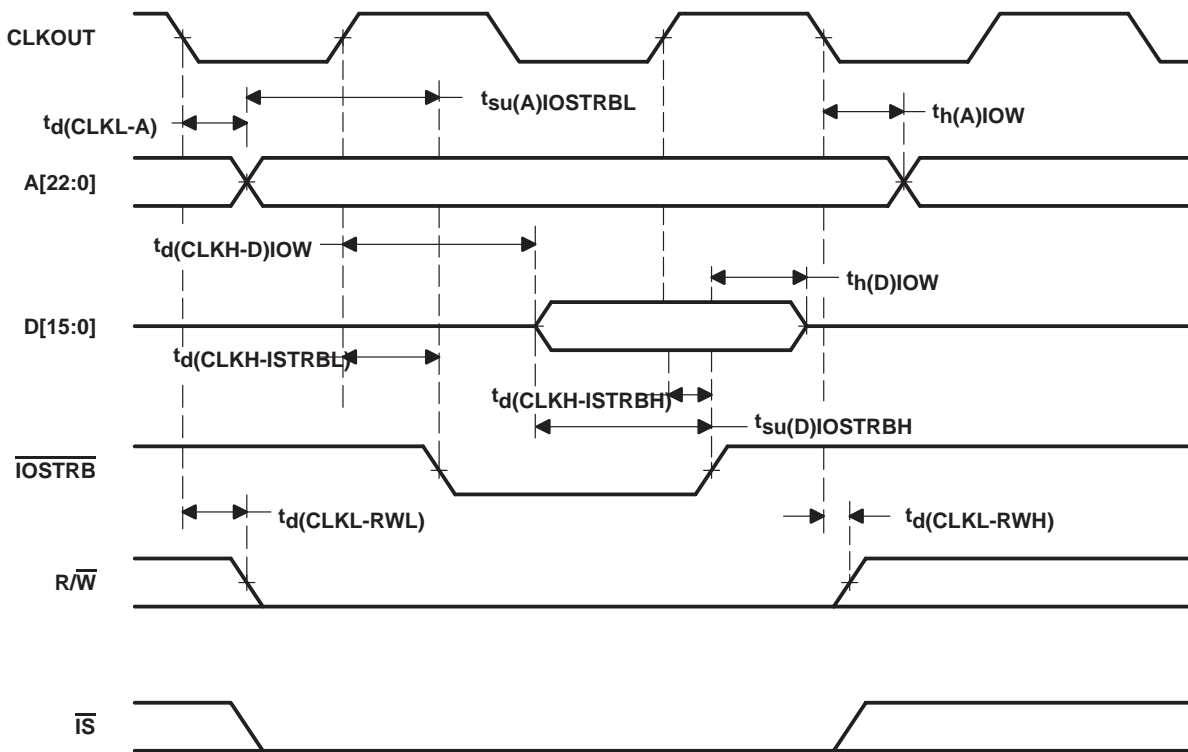
### 5.7.4 Parallel I/O Port Write

Table 5–11 assumes testing over recommended operating conditions,  $\overline{\text{IOSTRB}} = 0$ , and  $H = 0.5t_{c(\text{CO})}$  (see Figure 5–8).

**Table 5–11. Parallel I/O Port Write Switching Characteristics†**

PARAMETER		MIN	MAX	UNIT
$t_{d(\text{CLKL-A})}$	Delay time, CLKOUT low to address valid	0	3	ns
$t_{d(\text{CLKH-ISTRBL})}$	Delay time, CLKOUT high to $\overline{\text{IOSTRB}}$ low	0	3	ns
$t_{d(\text{CLKH-D})\text{IOW}}$	Delay time, CLKOUT high to write data valid	H-5	H+8	ns
$t_{d(\text{CLKH-ISTRBH})}$	Delay time, CLKOUT high to $\overline{\text{IOSTRB}}$ high	0	3	ns
$t_{d(\text{CLKL-RWL})}$	Delay time, CLKOUT low to R/W low	0	3	ns
$t_{d(\text{CLKL-RWH})}$	Delay time, CLKOUT low to R/W high	0	3	ns
$t_{h(\text{A})\text{IOW}}$	Hold time, address valid after CLKOUT low	0	3	ns
$t_{h(\text{D})\text{IOW}}$	Hold time, write data after $\overline{\text{IOSTRB}}$ high	H-3	H+7	ns
$t_{su(\text{D})\text{IOSTRBH}}$	Setup time, write data before $\overline{\text{IOSTRB}}$ high	H-7	H+1	ns
$t_{su(\text{A})\text{IOSTRBL}}$	Setup time, address valid before $\overline{\text{IOSTRB}}$ low	H-2	H+2	ns

† Address and  $\overline{\text{IS}}$  timings are included in timings referenced as address.



NOTE A: A[22:16] apply to DMA accesses to extended I/O, DATA, PROGRAM memory. The CPU has access to **only** extended PROGRAM memory.

**Figure 5–8. Parallel I/O Port Write**

## 5.8 Ready Timing for Externally Generated Wait States

Table 5–12 and Table 5–13 assume testing over recommended operating conditions and  $H = 0.5t_{c(CO)}$  (see Figure 5–9, Figure 5–10, Figure 5–11, and Figure 5–12).

**Table 5–12. Ready Timing Requirements for Externally Generated Wait States†**

		MIN	MAX	UNIT
$t_{su}(RDY)$	Setup time, READY before CLKOUT low	7		ns
$t_h(RDY)$	Hold time, READY after CLKOUT low	0		ns
$t_v(RDY)MSTRB$	Valid time, READY after $\overline{MSTRB}$ low‡		4H–9	ns
$t_h(RDY)MSTRB$	Hold time, READY after $\overline{MSTRB}$ low‡	4H		ns
$t_v(RDY)IOSTRB$	Valid time, READY after $\overline{IOSTRB}$ low‡		5H–9	ns
$t_h(RDY)IOSTRB$	Hold time, READY after $\overline{IOSTRB}$ low‡	5H		ns

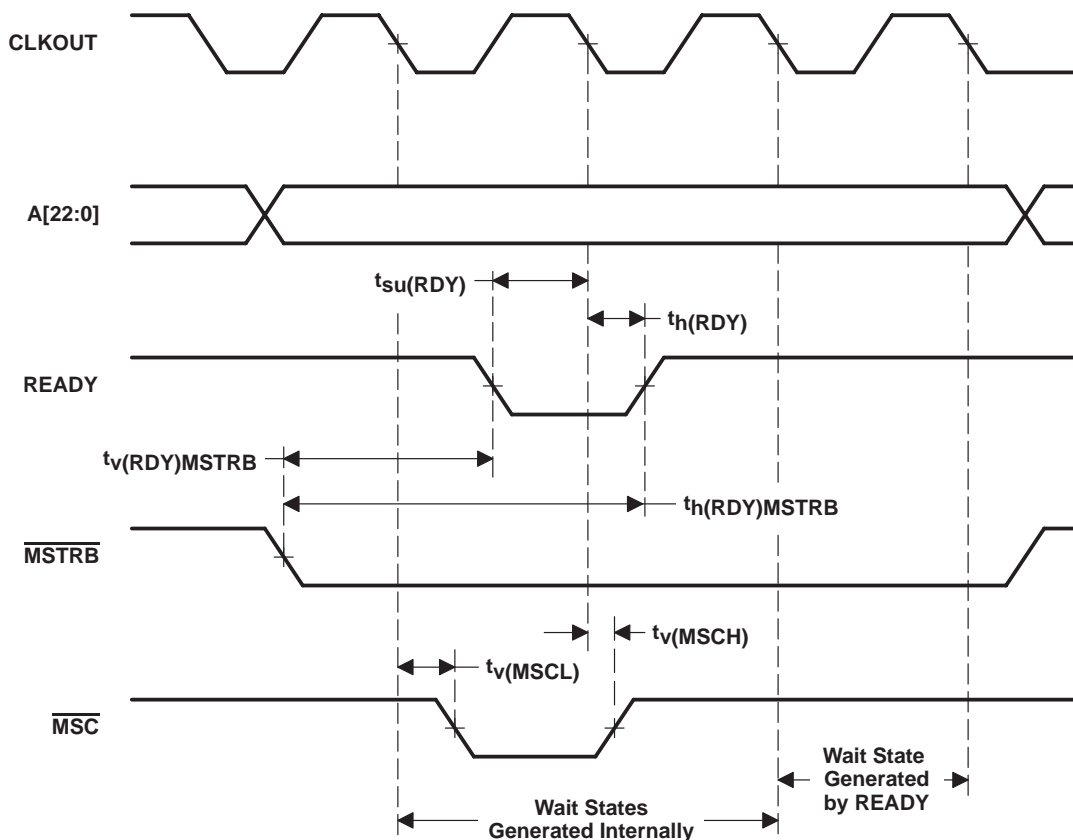
† The hardware wait states can be used only in conjunction with the software wait states to extend the bus cycles. To generate wait states using READY, at least two software wait states must be programmed.

‡ These timings are included for reference only. The critical timings for READY are those referenced to CLKOUT.

**Table 5–13. Ready Switching Characteristics for Externally Generated Wait States†**

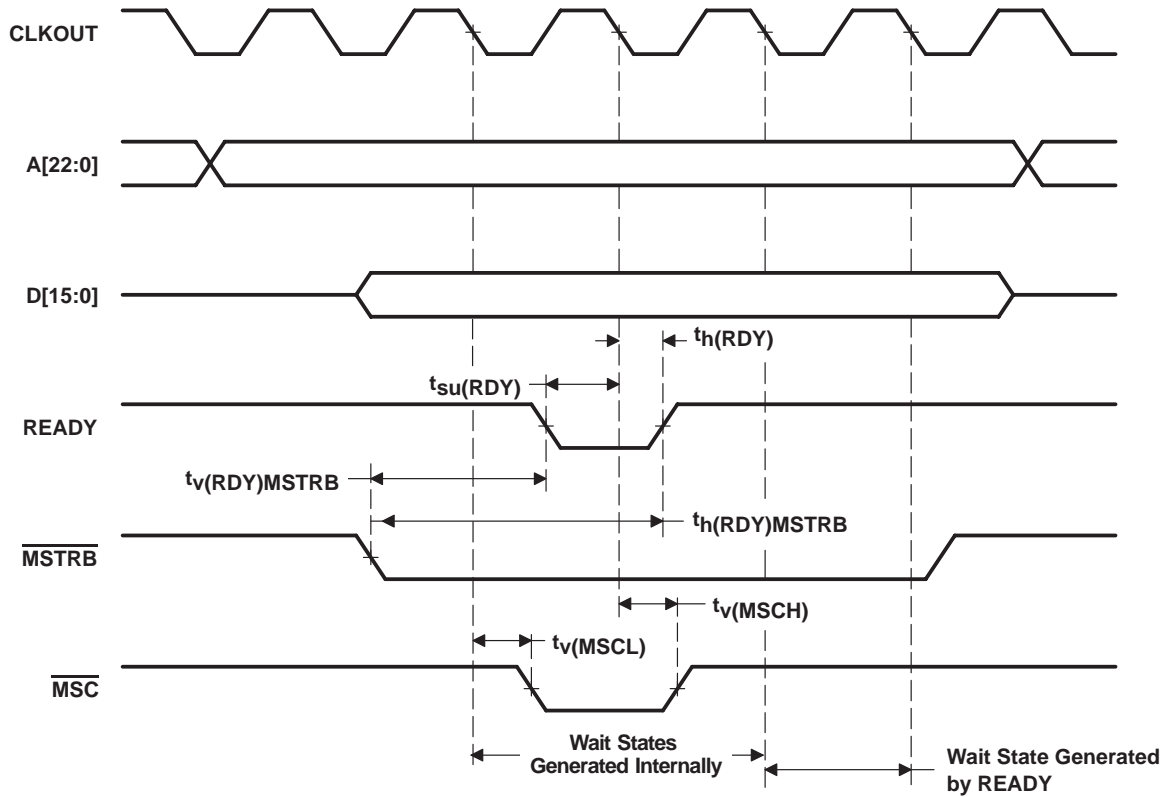
PARAMETER		MIN	MAX	UNIT
$t_d(MSCL)$	Delay time, CLKOUT low to $\overline{MSC}$ low	0	3	ns
$t_d(MSCH)$	Delay time, CLKOUT low to $\overline{MSC}$ high	0	3	ns

† The hardware wait states can be used only in conjunction with the software wait states to extend the bus cycles. To generate wait states by READY, at least two software wait states must be programmed. READY is not sampled until the completion of the internal software wait states.



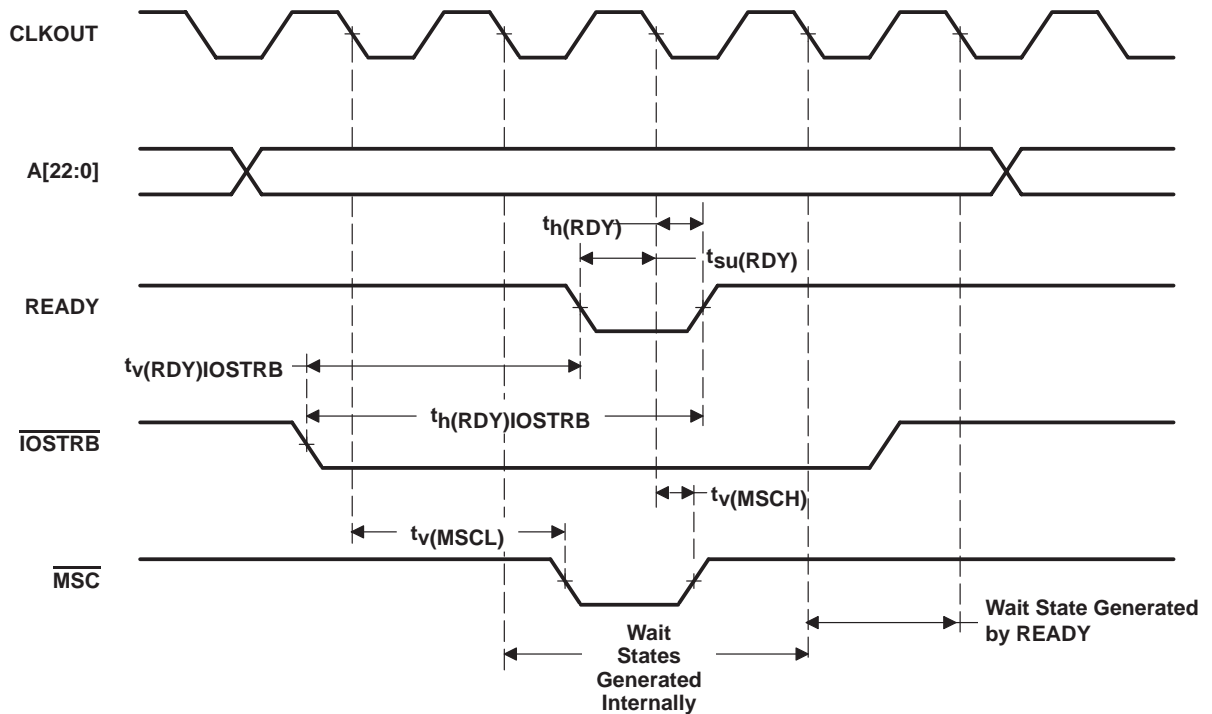
NOTE A: A[22:16] apply to DMA accesses to extended I/O, DATA, PROGRAM memory. The CPU has access to **only** extended PROGRAM memory.

**Figure 5–9. Memory Read With Externally Generated Wait States**



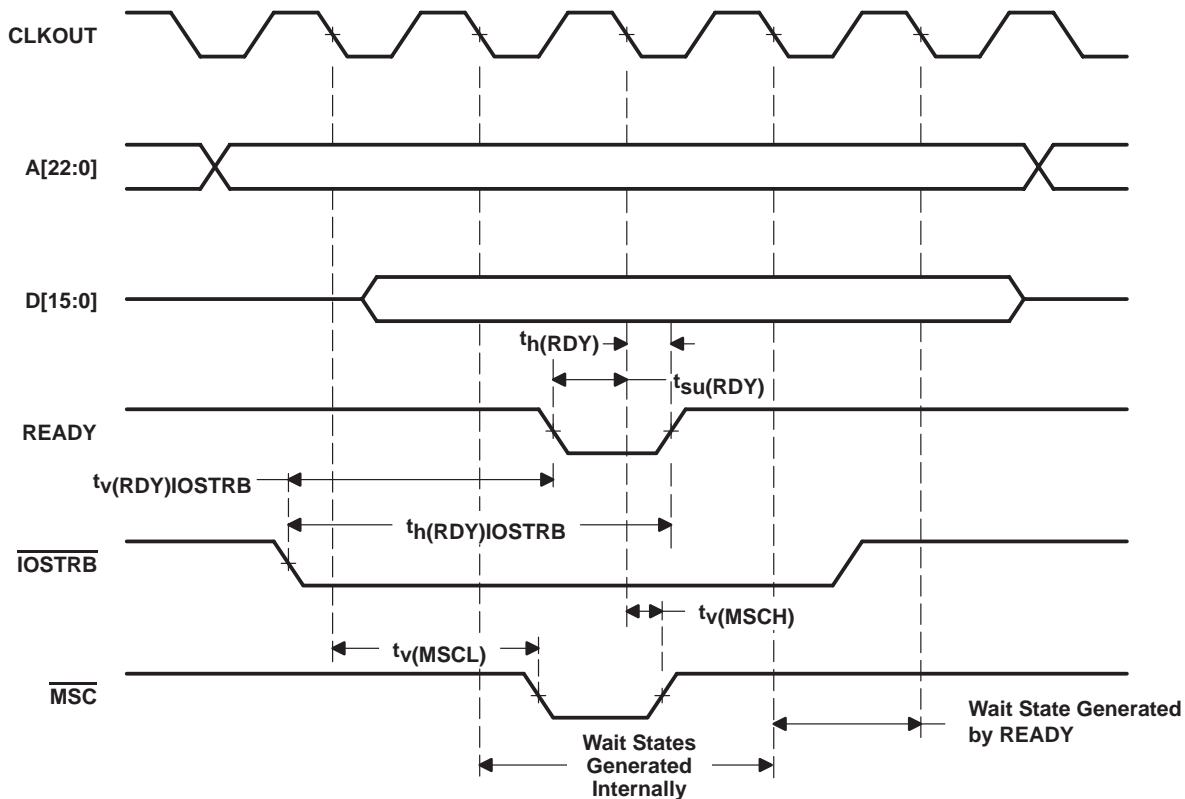
NOTE A: A[22:16] apply to DMA accesses to extended I/O, DATA, PROGRAM memory. The CPU has access to **only** extended PROGRAM memory.

**Figure 5-10. Memory Write With Externally Generated Wait States**



NOTE A: A[22:16] apply to DMA accesses to extended I/O, DATA, PROGRAM memory. The CPU has access to **only** extended PROGRAM memory.

**Figure 5–11. I/O Read With Externally Generated Wait States**



NOTE A: A[22:16] apply to DMA accesses to extended I/O, DATA, PROGRAM memory. The CPU has access to **only** extended PROGRAM memory.

Figure 5-12. I/O Write With Externally Generated Wait States



## 5.9 $\overline{\text{HOLD}}$ and $\overline{\text{HOLDA}}$ Timings

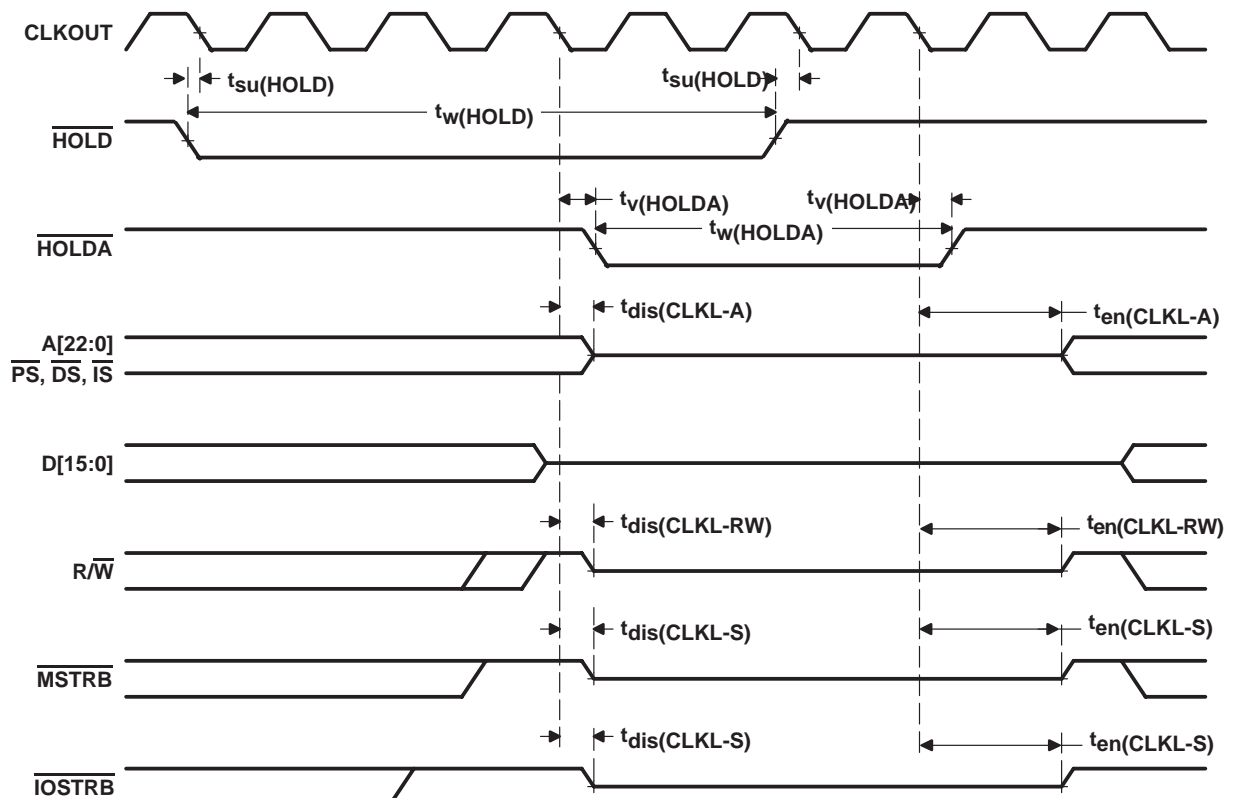
Table 5–14 and Table 5–15 assume testing over recommended operating conditions and  $H = 0.5t_{c(\text{CO})}$  (see Figure 5–13).

Table 5–14.  $\overline{\text{HOLD}}$  and  $\overline{\text{HOLDA}}$  Timing Requirements

		MIN	MAX	UNIT
$t_{w(\text{HOLD})}$	Pulse duration, $\overline{\text{HOLD}}$ low	4H+8		ns
$t_{su(\text{HOLD})}$	Setup time, $\overline{\text{HOLD}}$ low/high before CLKOUT low	8		ns

Table 5–15.  $\overline{\text{HOLD}}$  and  $\overline{\text{HOLDA}}$  Switching Characteristics

PARAMETER		MIN	MAX	UNIT
$t_{dis(\text{CLKL-A})}$	Disable time, address, $\overline{\text{PS}}$ , $\overline{\text{DS}}$ , $\overline{\text{IS}}$ high impedance from CLKOUT low		5	ns
$t_{dis(\text{CLKL-RW})}$	Disable time, $\overline{\text{R/W}}$ high impedance from CLKOUT low		5	ns
$t_{dis(\text{CLKL-S})}$	Disable time, $\overline{\text{MSTRB}}$ , $\overline{\text{IOSTRB}}$ high impedance from CLKOUT low		5	ns
$t_{en(\text{CLKL-A})}$	Enable time, address, $\overline{\text{PS}}$ , $\overline{\text{DS}}$ , $\overline{\text{IS}}$ from CLKOUT low		2H+5	ns
$t_{en(\text{CLKL-RW})}$	Enable time, $\overline{\text{R/W}}$ enabled from CLKOUT low		2H+5	ns
$t_{en(\text{CLKL-S})}$	Enable time, $\overline{\text{MSTRB}}$ , $\overline{\text{IOSTRB}}$ enabled from CLKOUT low	1	2H+5	ns
$t_{v(\text{HOLDA})}$	Valid time, $\overline{\text{HOLDA}}$ low after CLKOUT low	0	4	ns
	Valid time, $\overline{\text{HOLDA}}$ high after CLKOUT low	0	4	ns
$t_{w(\text{HOLDA})}$	Pulse duration, $\overline{\text{HOLDA}}$ low duration	2H–1		ns



NOTE A: A[22:16] apply to DMA accesses to extended I/O, DATA, PROGRAM memory. The CPU has access to **only** extended PROGRAM memory.

Figure 5–13.  $\overline{\text{HOLD}}$  and  $\overline{\text{HOLDA}}$  Timings

## 5.10 Reset, $\overline{\text{BIO}}$ , Interrupt, and $\overline{\text{MP/MC}}$ Timings

Table 5–16 assumes testing over recommended operating conditions and  $H = 0.5t_{c(\text{CO})}$  (see Figure 5–14, Figure 5–15, and Figure 5–16).

**Table 5–16. Reset,  $\overline{\text{BIO}}$ , Interrupt, and  $\overline{\text{MP/MC}}$  Timing Requirements**

		MIN	MAX	UNIT
$t_{\text{h}}(\text{RS})$	Hold time, $\overline{\text{RS}}$ after CLKOUT low	0		ns
$t_{\text{h}}(\text{BIO})$	Hold time, $\overline{\text{BIO}}$ after CLKOUT low	0		ns
$t_{\text{h}}(\text{INT})$	Hold time, $\overline{\text{INTn}}$ , $\overline{\text{NMI}}$ , after CLKOUT low <sup>†</sup>	0		ns
$t_{\text{h}}(\text{MPMC})$	Hold time, $\overline{\text{MP/MC}}$ after CLKOUT low	0		ns
$t_{\text{w}}(\text{RSL})$	Pulse duration, $\overline{\text{RS}}$ low <sup>‡§</sup>	4H+4		ns
$t_{\text{w}}(\text{BIO})\text{S}$	Pulse duration, $\overline{\text{BIO}}$ low, synchronous	2H+1		ns
$t_{\text{w}}(\text{BIO})\text{A}$	Pulse duration, $\overline{\text{BIO}}$ low, asynchronous	4H		ns
$t_{\text{w}}(\text{INT})\text{S}$	Pulse duration, $\overline{\text{INTn}}$ , $\overline{\text{NMI}}$ high (synchronous)	2H+1		ns
$t_{\text{w}}(\text{INT})\text{A}$	Pulse duration, $\overline{\text{INTn}}$ , $\overline{\text{NMI}}$ high (asynchronous)	4H		ns
$t_{\text{w}}(\text{INTL})\text{S}$	Pulse duration, $\overline{\text{INTn}}$ , $\overline{\text{NMI}}$ low (synchronous)	2H+1		ns
$t_{\text{w}}(\text{INTL})\text{A}$	Pulse duration, $\overline{\text{INTn}}$ , $\overline{\text{NMI}}$ low (asynchronous)	4H		ns
$t_{\text{w}}(\text{INTL})\text{WKP}$	Pulse duration, $\overline{\text{INTn}}$ , $\overline{\text{NMI}}$ low for IDLE2/IDLE3 wakeup	8		ns
$t_{\text{su}}(\text{RS})$	Setup time, $\overline{\text{RS}}$ before X2/CLKIN low <sup>¶</sup>	6		ns
$t_{\text{su}}(\text{BIO})$	Setup time, $\overline{\text{BIO}}$ before CLKOUT low	7	10	ns
$t_{\text{su}}(\text{INT})$	Setup time, $\overline{\text{INTn}}$ , $\overline{\text{NMI}}$ , $\overline{\text{RS}}$ before CLKOUT low	8	10	ns
$t_{\text{su}}(\text{MPMC})$	Setup time, $\overline{\text{MP/MC}}$ before CLKOUT low	8		ns

<sup>†</sup> The external interrupts ( $\overline{\text{INT0}}$ – $\overline{\text{INT3}}$ ,  $\overline{\text{NMI}}$ ) are synchronized to the core CPU by way of a two-flip-flop synchronizer which samples these inputs with consecutive falling edges of CLKOUT. The input to the interrupt pins is required to represent a 1-0-0 sequence at the timing that is corresponding to three CLKOUT sampling sequences.

<sup>‡</sup> If the PLL mode is selected, then at power-on sequence, or at wakeup from IDLE3,  $\overline{\text{RS}}$  must be held low for at least 50  $\mu\text{s}$  to ensure synchronization and lock-in of the PLL.

<sup>§</sup> Note that  $\overline{\text{RS}}$  may cause a change in clock frequency, therefore changing the value of H.

<sup>¶</sup> Divide-by-two mode

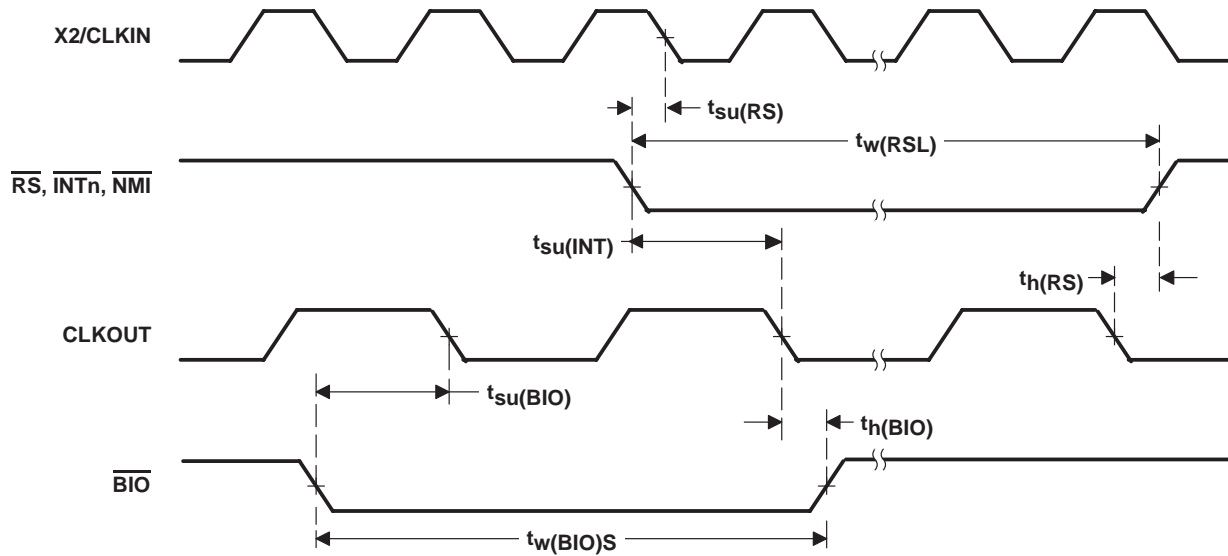
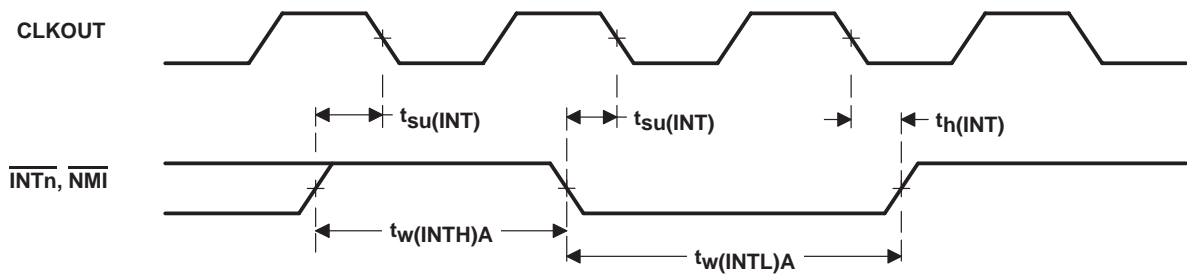
Figure 5-14. Reset and  $\overline{BIO}$  Timings

Figure 5-15. Interrupt Timing

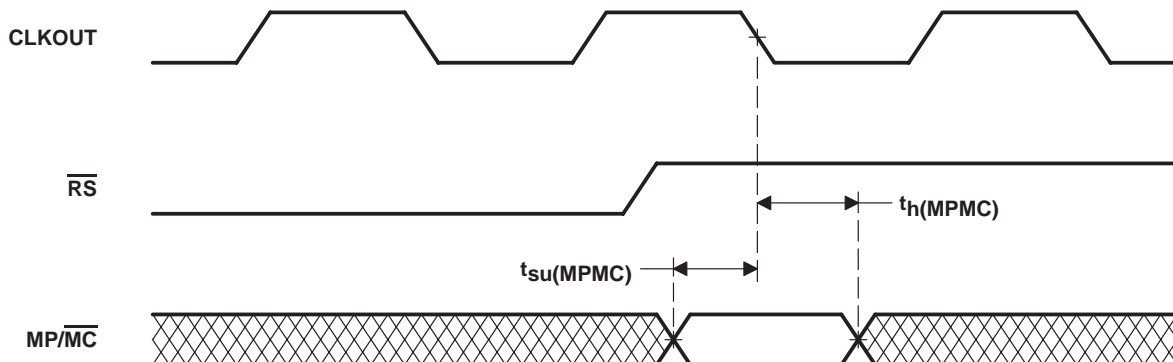


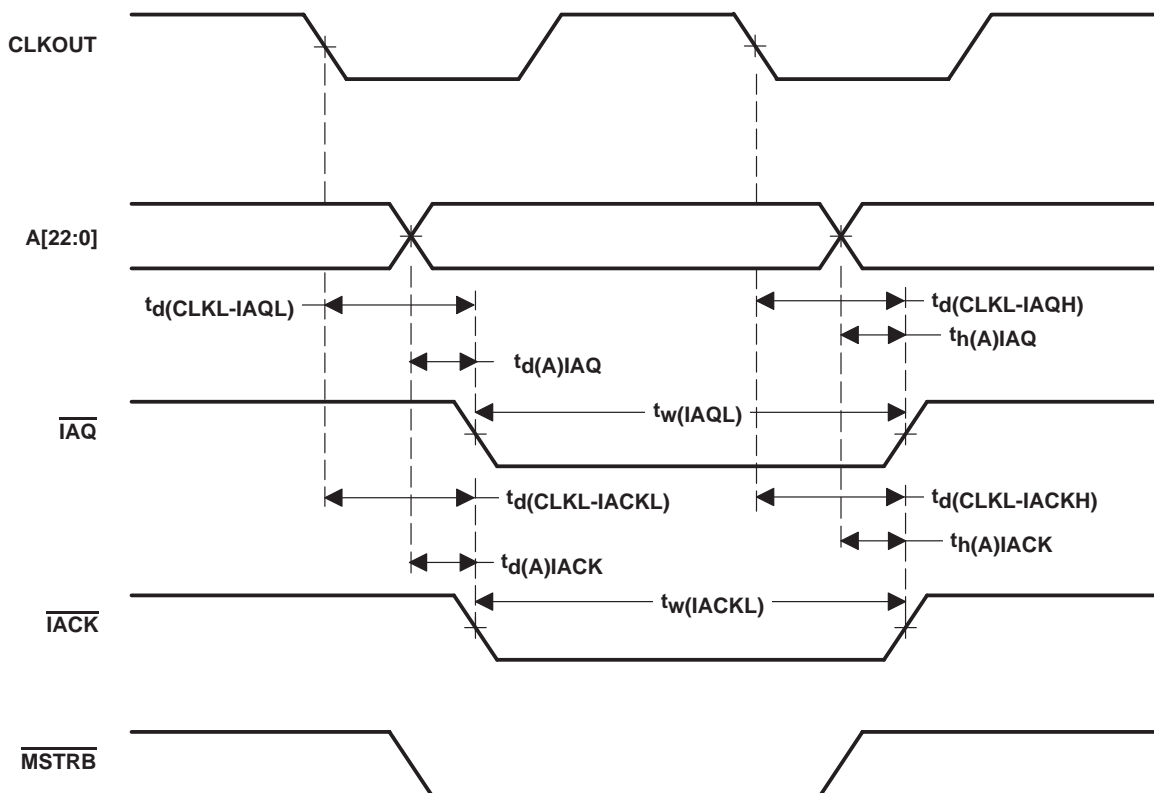
Figure 5-16. MP/MC Timing

### 5.11 Instruction Acquisition ( $\overline{\text{IAQ}}$ ) and Interrupt Acknowledge ( $\overline{\text{IACK}}$ ) Timings

Table 5–17 assumes testing over recommended operating conditions and  $H = 0.5t_{c(\text{CO})}$  (see Figure 5–17).

**Table 5–17. Instruction Acquisition ( $\overline{\text{IAQ}}$ ) and Interrupt Acknowledge ( $\overline{\text{IACK}}$ ) Switching Characteristics**

PARAMETER		MIN	MAX	UNIT
$t_{d(\text{CLKL-IAQL})}$	Delay time, CLKOUT low to $\overline{\text{IAQ}}$ low	0	3	ns
$t_{d(\text{CLKL-IAQH})}$	Delay time, CLKOUT low to $\overline{\text{IAQ}}$ high	0	3	ns
$t_{d(\text{A})\text{IAQ}}$	Delay time, address valid to $\overline{\text{IAQ}}$ low		1	ns
$t_{d(\text{CLKL-IACKL})}$	Delay time, CLKOUT low to $\overline{\text{IACK}}$ low	0	3	ns
$t_{d(\text{CLKL-IACKH})}$	Delay time, CLKOUT low to $\overline{\text{IACK}}$ high	0	3	ns
$t_{d(\text{A})\text{IACK}}$	Delay time, address valid to $\overline{\text{IACK}}$ low		1	ns
$t_{h(\text{A})\text{IAQ}}$	Hold time, $\overline{\text{IAQ}}$ high after address invalid	-2		ns
$t_{h(\text{A})\text{IACK}}$	Hold time, $\overline{\text{IACK}}$ high after address invalid	-2		ns
$t_w(\text{IAQL})$	Pulse duration, $\overline{\text{IAQ}}$ low	2H-2		ns
$t_w(\text{IACKL})$	Pulse duration, $\overline{\text{IACK}}$ low	2H-2		ns



NOTE A: A[22:16] apply to DMA accesses to extended I/O, DATA, PROGRAM memory. The CPU has access to **only** extended PROGRAM memory.

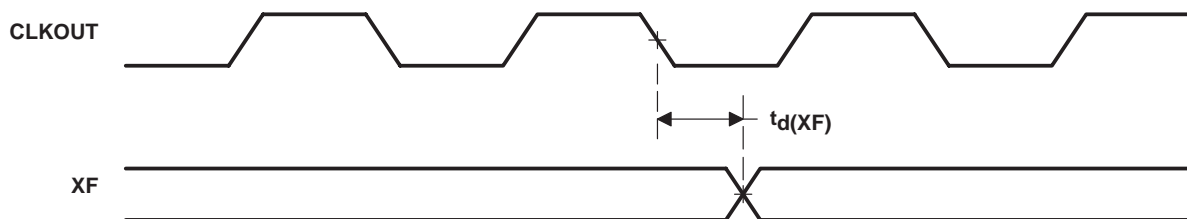
**Figure 5–17.  $\overline{\text{IAQ}}$  and  $\overline{\text{IACK}}$  Timings**

## 5.12 External Flag (XF) and TOUT Timings

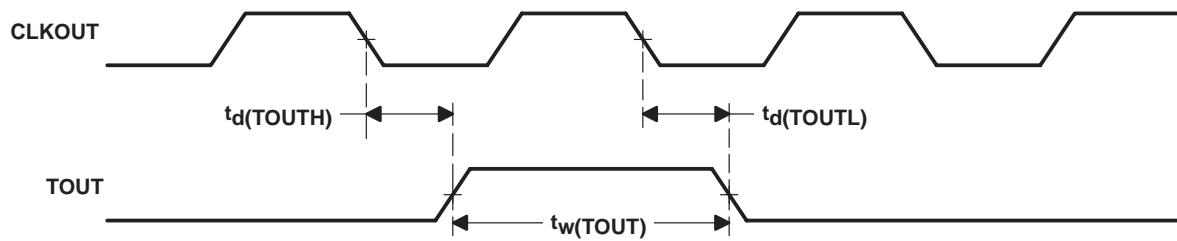
Table 5–18 assumes testing over recommended operating conditions and  $H = 0.5t_{c(CO)}$  (see Figure 5–18 and Figure 5–19).

**Table 5–18. External Flag (XF) and TOUT Switching Characteristics**

PARAMETER		MIN	MAX	UNIT
$t_{d(XF)}$	Delay time, CLKOUT low to XF high	0	2	ns
	Delay time, CLKOUT low to XF low	0	2	
$t_{d(TOUTH)}$	Delay time, CLKOUT low to TOUT high	0	4	ns
$t_{d(TOURL)}$	Delay time, CLKOUT low to TOUT low	0	4	ns
$t_w(TOUT)$	Pulse duration, TOUT	2H		ns



**Figure 5–18. XF Timing**



**Figure 5–19. TOUT Timing**

## 5.13 Multichannel Buffered Serial Port (McBSP) Timing

### 5.13.1 McBSP Transmit and Receive Timings

Table 5–19 and Table 5–20 assume testing over recommended operating conditions and  $H = 0.5t_{c(CO)}$  (see Figure 5–20 and Figure 5–21).

**Table 5–19. McBSP Transmit and Receive Timing Requirements†**

			MIN	MAX	UNIT
$t_c(\text{BCKRX})$	Cycle time, BCLKR/X	BCLKR/X ext	4H		ns
$t_w(\text{BCKRX})$	Pulse duration, BCLKR/X or BCLKR/X high	BCLKR/X ext	2H–1		ns
$t_h(\text{BCKRL-BFRH})$	Hold time, external BFSR high after BCLKR low	BCLKR int	0		ns
		BCLKR ext	4		
$t_h(\text{BCKRL-BDRV})$	Hold time, BDR valid after BCLKR low	BCLKR int	0		ns
		BCLKR ext	4		
$t_h(\text{BCKXL-BFXH})$	Hold time, external BFSX high after BCLKX low	BCLKX int	0		ns
		BCLKX ext	4		
$t_{su}(\text{BFRH-BCKRL})$	Setup time, external BFSR high before BCLKR low	BCLKR int	7		ns
		BCLKR ext	2		
$t_{su}(\text{BDRV-BCKRL})$	Setup time, BDR valid before BCLKR low	BCLKR int	7		ns
		BCLKR ext	2		
$t_{su}(\text{BFXH-BCKXL})$	Setup time, external BFSX high before BCLKX low	BCLKX int	7		ns
		BCLKX ext	2		
$t_r(\text{BCKRX})$	Rise time, BCKR/X	BCLKR/X ext		8	ns
$t_f(\text{BCKRX})$	Fall time, BCKR/X	BCLKR/X ext		8	ns

† Polarity bits CLKRP = CLKXP = FSRP = FSXP = 0. If the polarity of any of the signals is inverted, then the timing references of that signal are also inverted.

Table 5–20. McBSP Transmit and Receive Switching Characteristics†

PARAMETER			MIN	MAX	UNIT	
$t_c(\text{BCKRX})$	Cycle time, BCLKR/X	BCLKR/X int	4H		ns	
$t_w(\text{BCKRXH})$	Pulse duration, BCLKR/X high	BCLKR/X int	D–3‡	D+1‡	ns	
$t_w(\text{BCKRXL})$	Pulse duration, BCLKR/X low	BCLKR/X int	C–3‡	C+1‡	ns	
$t_d(\text{BCKRH-BFRV})$	Delay time, BCLKR high to internal BFSR valid	BCLKR int	–2	2	ns	
$t_d(\text{BCKXH-BFXV})$	Delay time, BCLKX high to internal BFSX valid	BCLKX int	0	6	ns	
		BCLKX ext	4	12		
$t_{\text{dis}}(\text{BCKXH-BDXHZ})$	Disable time, BCLKX high to BDX high impedance following last data bit	BCLKX int	–4	7	ns	
		BCLKX ext	3	9		
$t_d(\text{BCKXH-BDXV})$	Delay time, BCLKX high to BDX valid. This applies to all bits except the first bit transmitted.	BCLKX int	0	7	ns	
		BCLKX ext	4	12		
	Delay time, BCLKX high to BDX valid. §¶ Only applies to first bit transmitted when in Data Delay 1 or 2 (XDATDLY=01b or 10b) modes	DXENA = 0	BCLKX int			7
			BCLKX ext			12
$t_e(\text{BCKXH-BDX})$	Enable time, BCLKX high to BDX driven. §¶ Only applies to first bit transmitted when in Data Delay 1 or 2 (XDATDLY=01b or 10b) modes	DXENA = 0	BCLKX int	–4	ns	
			BCLKX ext	2		
$t_d(\text{BFXH-BDXV})$	Delay time, BFSX high to BDX valid. §¶ Only applies to first bit transmitted when in Data Delay 0 (XDATDLY=00b) mode.	DXENA = 0	BFSX int		ns	
			BFSX ext			2
$t_e(\text{BFXH-BDX})$	Enable time, BFSX high to BDX driven. §¶ Only applies to first bit transmitted when in Data Delay 0 (XDATDLY=00b) mode	DXENA = 0	BFSX int	–1	ns	
			BFSX ext	2		

† Polarity bits CLKRP = CLKXP = FSRP = FSXP = 0. If the polarity of any of the signals is inverted, then the timing references of that signal are also inverted.

‡  $T = \text{BCLKRX period} = (1 + \text{CLKGDV}) * 2H$

C = BCLKRX low pulse width = T/2 when CLKGDV is odd or zero and = (CLKGDV/2) \* 2H when CLKGDV is even

D = BCLKRX high pulse width = T/2 when CLKGDV is odd or zero and = (CLKGDV/2 + 1) \* 2H when CLKGDV is even

§ See the *TMS320C54x DSP Reference Set, Volume 5: Enhanced Peripherals* (literature number SPRU302) for a description of the DX enable (DXENA) and data delay features of the McBSP.

¶ The transmit delay enable (DXENA) and A-bis mode (ABIS) features of the McBSP are not implemented on the TMS320VC5409.

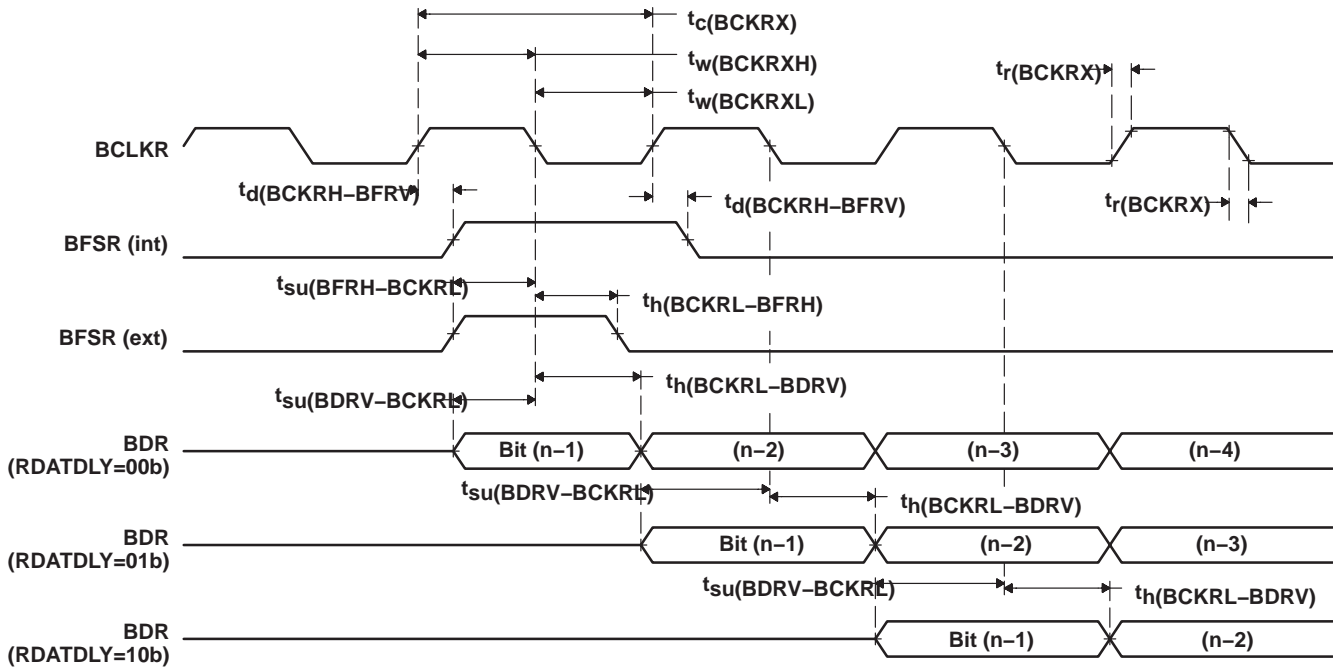


Figure 5–20. McBSP Receive Timings

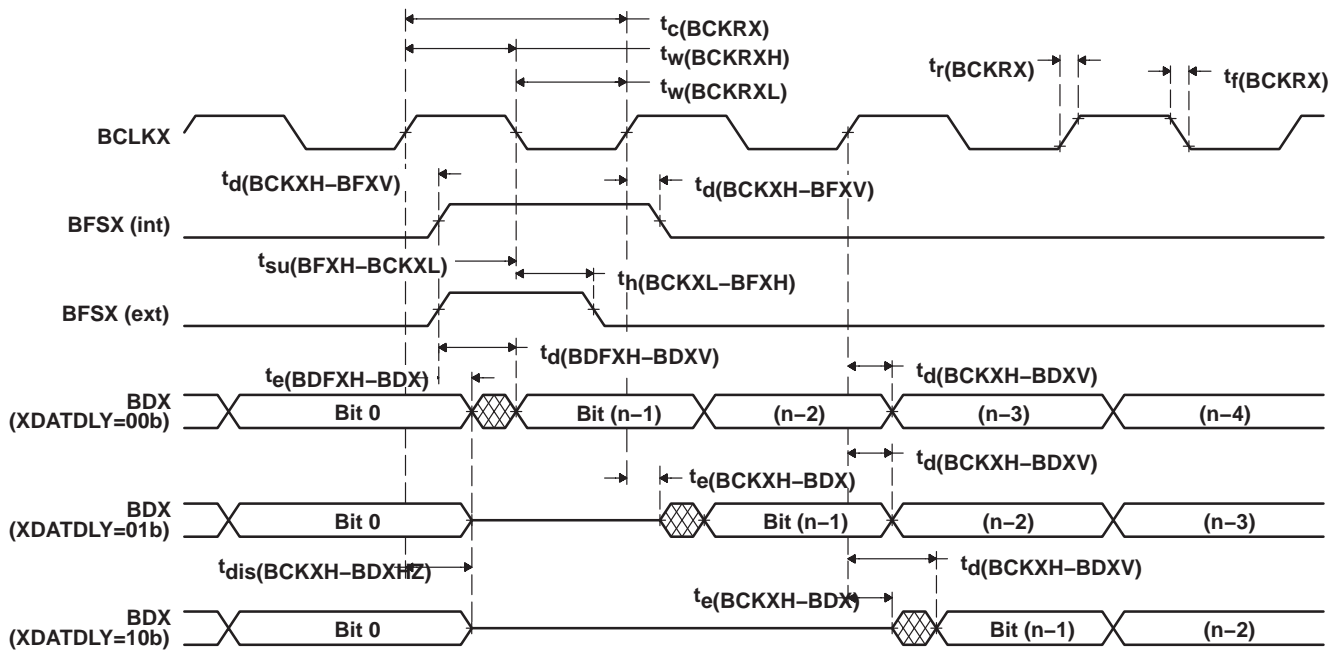


Figure 5–21. McBSP Transmit Timings



### 5.13.2 McBSP General-Purpose I/O Timing

Table 5–21 and Table 5–22 assume testing over recommended operating conditions (see Figure 5–22).

**Table 5–21. McBSP General-Purpose I/O Timing Requirements**

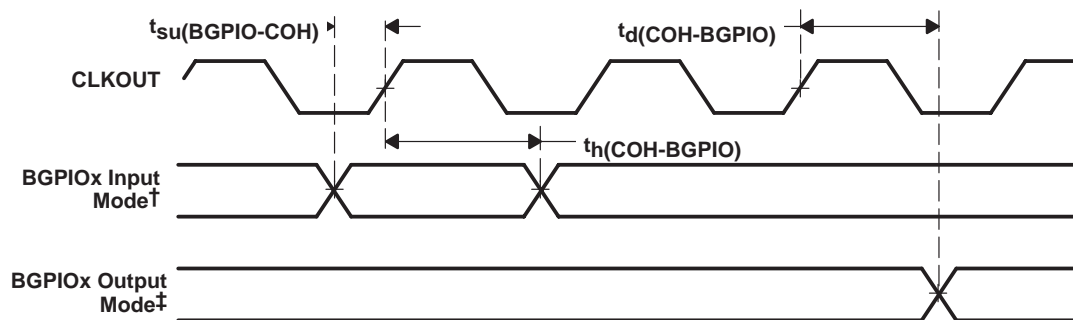
	MIN	MAX	UNIT
$t_{su}(BGPIO-COH)$ Setup time, BGPIOx input mode before CLKOUT high <sup>†</sup>	9		ns
$t_h(COH-BGPIO)$ Hold time, BGPIOx input mode after CLKOUT high <sup>†</sup>	0		ns

<sup>†</sup> BGPIOx refers to BCLKRx, BFSRx, BDRx, BCLKXx, or BFSXx when configured as a general-purpose input.

**Table 5–22. McBSP General-Purpose I/O Switching Characteristics**

PARAMETER	MIN	MAX	UNIT
$t_d(COH-BGPIO)$ Delay time, CLKOUT high to BGPIOx output mode <sup>‡</sup>	–10	10	ns

<sup>‡</sup> BGPIOx refers to BCLKRx, BFSRx, BCLKXx, BFSXx, or BDXx when configured as a general-purpose output.



<sup>†</sup> BGPIOx refers to BCLKRx, BFSRx, BDRx, BCLKXx, or BFSXx when configured as a general-purpose input.

<sup>‡</sup> BGPIOx refers to BCLKRx, BFSRx, BCLKXx, BFSXx, or BDXx when configured as a general-purpose output.

**Figure 5–22. McBSP General-Purpose I/O Timings**

### 5.13.3 McBSP as SPI Master or Slave Timing

Table 5–23 to Table 5–30 assume testing over recommended operating conditions and  $H = 0.5t_{c(CO)}$  (see Figure 5–23, Figure 5–24, Figure 5–25, and Figure 5–26).

**Table 5–23. McBSP as SPI Master or Slave Timing Requirements (CLKSTP = 10b, CLKXP = 0)†**

		MASTER		SLAVE		UNIT
		MIN	MAX	MIN	MAX	
$t_{su}(BDRV-BCKXL)$	Setup time, BDR valid before BCLKX low	10		- 12H		ns
$t_h(BCKXL-BDRV)$	Hold time, BDR valid after BCLKX low	0		5 + 12H		ns
$t_{su}(BFXL-BCKXH)$	Setup time, BFSX low before BCLKX high			10		ns
$t_c(BCKX)$	Cycle time, BCLKX	12H		32H		ns

† For all SPI slave modes, CLKG is programmed as 1/2 of the CPU clock by setting CLKSM = CLKGDV = 1.

**Table 5–24. McBSP as SPI Master or Slave Switching Characteristics (CLKSTP = 10b, CLKXP = 0)†**

PARAMETER	MASTER‡		SLAVE		UNIT
	MIN	MAX	MIN	MAX	
$t_h(BCKXL-BFXL)$	T - 4 T + 4				ns
$t_d(BFXL-BCKXH)$	C - 5	C + 3			ns
$t_d(BCKXH-BDXV)$	- 3	7	6H + 5	10H + 14	ns
$t_{dis}(BCKXL-BDXHZ)$	C - 2	C + 3			ns
$t_{dis}(BFXH-BDXHZ)$			2H + 3	6H + 17	ns
$t_d(BFXL-BDXV)$			4H + 2	8H + 17	ns

† For all SPI slave modes, CLKG is programmed as 1/2 of the CPU clock by setting CLKSM = CLKGDV = 1.

‡ T = BCLKX period = (1 + CLKGDV) \* 2H

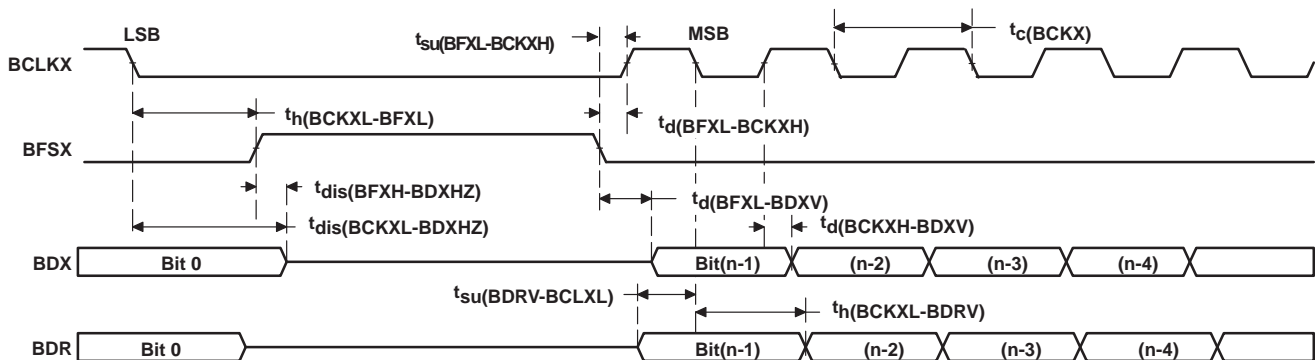
C = BCLKX low pulse width = T/2 when CLKGDV is odd or zero and = (CLKGDV/2) \* 2H when CLKGDV is even

§ FSRP = FSXP = 1. As a SPI master, BFSX is inverted to provide active-low slave-enable output. As a slave, the active-low signal input on BFSX and BFSR is inverted before being used internally.

CLKXM = FSXM = 1, CLKRM = FSRM = 0 for master McBSP

CLKXM = CLKRM = FSXM = FSRM = 0 for slave McBSP

¶ BFSX should be low before the rising edge of clock to enable slave devices and then begin a SPI transfer at the rising edge of the master clock (BCLKX).



**Figure 5–23. McBSP Timing as SPI Master or Slave: CLKSTP = 10b, CLKXP = 0**

Table 5–25. McBSP as SPI Master or Slave Timing Requirements (CLKSTP = 11b, CLKXP = 0)†

		MASTER		SLAVE		UNIT
		MIN	MAX	MIN	MAX	
$t_{su}(BDRV-BCKXL)$	Setup time, BDR valid before BCLKX low	10		- 12H		ns
$t_h(BCKXH-BDRV)$	Hold time, BDR valid after BCLKX high	0		5 + 12H		ns
$t_{su}(BFXL-BCKXH)$	Setup time, BFSX low before BCLKX high			10		ns
$t_c(BCKX)$	Cycle time, BCLKX			32H		ns

† For all SPI slave modes, CLKG is programmed as 1/2 of the CPU clock by setting CLKSM = CLKGDV = 1.

Table 5–26. McBSP as SPI Master or Slave Switching Characteristics (CLKSTP = 11b, CLKXP = 0)†

PARAMETER		MASTER‡		SLAVE		UNIT
		MIN	MAX	MIN	MAX	
$t_h(BCKXL-BFXL)$	Hold time, BFSX low after BCLKX low§	C - 4	C + 4			ns
$t_d(BFXL-BCKXH)$	Delay time, BFSX low to BCLKX high¶	T - 5	T + 3			ns
$t_d(BCKXL-BDXV)$	Delay time, BCLKX low to BDX valid	- 3	7	6H + 5	10H + 14	ns
$t_{dis}(BCKXL-BDXHZ)$	Disable time, BDX high impedance following last data bit from BCLKX low	- 2	4	6H + 3	10H + 17	ns
$t_d(BFXL-BDXV)$	Delay time, BFSX low to BDX valid	D - 1	D + 4	4H - 2	8H + 17	ns

† For all SPI slave modes, CLKG is programmed as 1/2 of the CPU clock by setting CLKSM = CLKGDV = 1.

‡ T = BCLKX period = (1 + CLKGDV) \* 2H

C = BCLKX low pulse width = T/2 when CLKGDV is odd or zero and = (CLKGDV/2) \* 2H when CLKGDV is even

D = BCLKX high pulse width = T/2 when CLKGDV is odd or zero and = (CLKGDV/2 + 1) \* 2H when CLKGDV is even

§ FSRP = FSXP = 1. As a SPI master, BFSX is inverted to provide active-low slave-enable output. As a slave, the active-low signal input on BFSX and BFSR is inverted before being used internally.

CLKXM = FSXM = 1, CLKRM = FSRM = 0 for master McBSP

CLKXM = CLKRM = FSXM = FSRM = 0 for slave McBSP

¶ BFSX should be low before the rising edge of clock to enable slave devices and then begin a SPI transfer at the rising edge of the master clock (BCLKX).

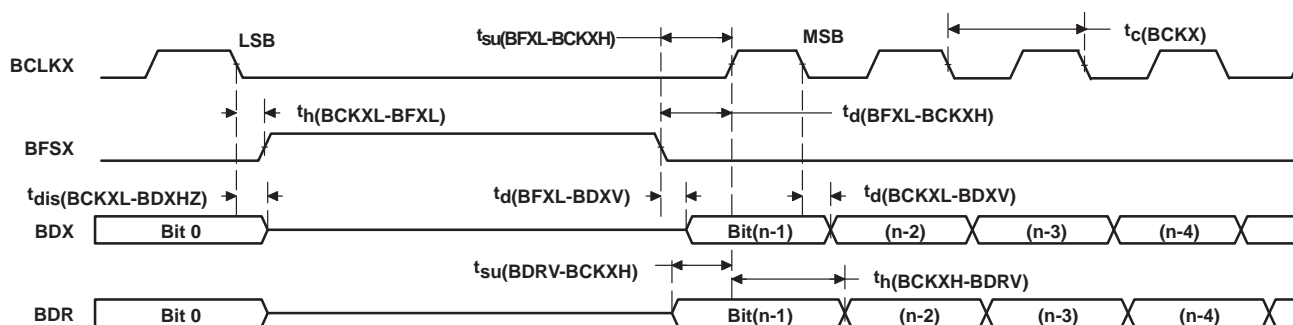


Figure 5–24. McBSP Timing as SPI Master or Slave: CLKSTP = 11b, CLKXP = 0

**Table 5–27. McBSP as SPI Master or Slave Timing Requirements (CLKSTP = 10b, CLKXP = 1)†**

		MASTER		SLAVE		UNIT
		MIN	MAX	MIN	MAX	
$t_{su}(BDRV-BCKXH)$	Setup time, BDR valid before BCLKX high	10		- 12H		ns
$t_h(BCKXH-BDRV)$	Hold time, BDR valid after BCLKX high	0		5 + 12H		ns
$t_{su}(BFXL-BCKXL)$	Setup time, BFSX low before BCLKX low			10		ns
$t_c(BCKX)$	Cycle time, BCLKX			32H		ns

† For all SPI slave modes, CLKG is programmed as 1/2 of the CPU clock by setting CLKSM = CLKGDV = 1.

**Table 5–28. McBSP as SPI Master or Slave Switching Characteristics (CLKSTP = 10b, CLKXP = 1)†**

PARAMETER		MASTER‡		SLAVE		UNIT
		MIN	MAX	MIN	MAX	
$t_h(BCKXH-BFXL)$	Hold time, BFSX low after BCLKX high§	T - 4	T + 4			ns
$t_d(BFXL-BCKXL)$	Delay time, BFSX low to BCLKX low¶	D - 5	D + 3			ns
$t_d(BCKXL-BDXV)$	Delay time, BCLKX low to BDX valid	- 3	7	6H + 5	10H + 14	ns
$t_{dis}(BCKXH-BDXHZ)$	Disable time, BDX high impedance following last data bit from BCLKX high	D - 2	D + 3			ns
$t_{dis}(BFXH-BDXHZ)$	Disable time, BDX high impedance following last data bit from BFSX high			2H + 3	6H + 17	ns
$t_d(BFXL-BDXV)$	Delay time, BFSX low to BDX valid			4H - 2	8H + 17	ns

† For all SPI slave modes, CLKG is programmed as 1/2 of the CPU clock by setting CLKSM = CLKGDV = 1.

‡ T = BCLKX period = (1 + CLKGDV) \* 2H

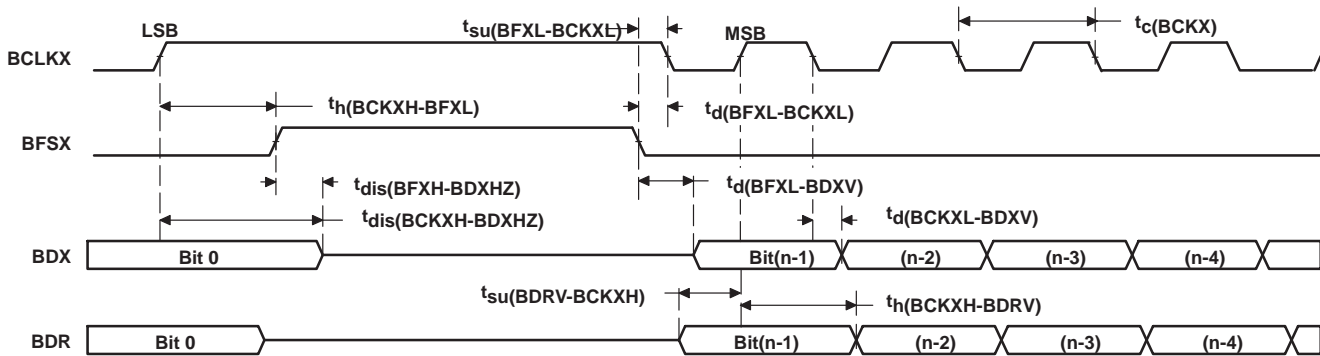
D = BCLKX high pulse width = T/2 when CLKGDV is odd or zero and = (CLKGDV/2 + 1) \* 2H when CLKGDV is even

§ FSRP = FSXP = 1. As a SPI master, BFSX is inverted to provide active-low slave-enable output. As a slave, the active-low signal input on BFSX and BFSR is inverted before being used internally.

CLKXM = FSXM = 1, CLKRM = FSRM = 0 for master McBSP

CLKXM = CLKRM = FSXM = FSRM = 0 for slave McBSP

¶ BFSX should be low before the rising edge of clock to enable slave devices and then begin a SPI transfer at the rising edge of the master clock (BCLKX).



**Figure 5–25. McBSP Timing as SPI Master or Slave: CLKSTP = 10b, CLKXP = 1**

Table 5–29. McBSP as SPI Master or Slave Timing Requirements (CLKSTP = 11b, CLKXP = 1)†

		MASTER		SLAVE		UNIT
		MIN	MAX	MIN	MAX	
$t_{su}(BDRV-BCKXL)$	Setup time, BDR valid before BCLKX low	10		– 12H		ns
$t_h(BCKXL-BDRV)$	Hold time, BDR valid after BCLKX low	0		5 + 12H		ns
$t_{su}(BFXL-BCKXL)$	Setup time, BFSX low before BCLKX low			10		ns
$t_c(BCKX)$	Cycle time, BCLKX			32H		ns

† For all SPI slave modes, CLKG is programmed as 1/2 of the CPU clock by setting CLKSM = CLKGDV = 1.

Table 5–30. McBSP as SPI Master or Slave Switching Characteristics (CLKSTP = 11b, CLKXP = 1)†

PARAMETER		MASTER‡		SLAVE		UNIT
		MIN	MAX	MIN	MAX	
$t_h(BCKXH-BFXL)$	Hold time, BFSX low after BCLKX high§	D – 4	D + 4			ns
$t_d(BFXL-BCKXL)$	Delay time, BFSX low to BCLKX low¶	T – 5	T + 3			ns
$t_d(BCKXH-BDXV)$	Delay time, BCLKX high to BDX valid	– 3	7	6H + 5	10H + 14	ns
$t_{dis}(BCKXH-BDXHZ)$	Disable time, BDX high impedance following last data bit from BCLKX high	– 2	4	6H + 3	10H + 17	ns
$t_d(BFXL-BDXV)$	Delay time, BFSX low to BDX valid	C – 1	C + 4	4H – 2	8H + 17	ns

† For all SPI slave modes, CLKG is programmed as 1/2 of the CPU clock by setting CLKSM = CLKGDV = 1.

‡ T = BCLKX period = (1 + CLKGDV) \* 2H

C = BCLKX low pulse width = T/2 when CLKGDV is odd or zero and = (CLKGDV/2) \* 2H when CLKGDV is even

D = BCLKX high pulse width = T/2 when CLKGDV is odd or zero and = (CLKGDV/2 + 1) \* 2H when CLKGDV is even

§ FSRP = FSXP = 1. As a SPI master, BFSX is inverted to provide active-low slave-enable output. As a slave, the active-low signal input on BFSX and BFSR is inverted before being used internally.

CLKXM = FSXM = 1, CLKRM = FSRM = 0 for master McBSP

CLKXM = CLKRM = FSXM = FSRM = 0 for slave McBSP

¶ BFSX should be low before the rising edge of clock to enable slave devices and then begin a SPI transfer at the rising edge of the master clock (BCLKX).

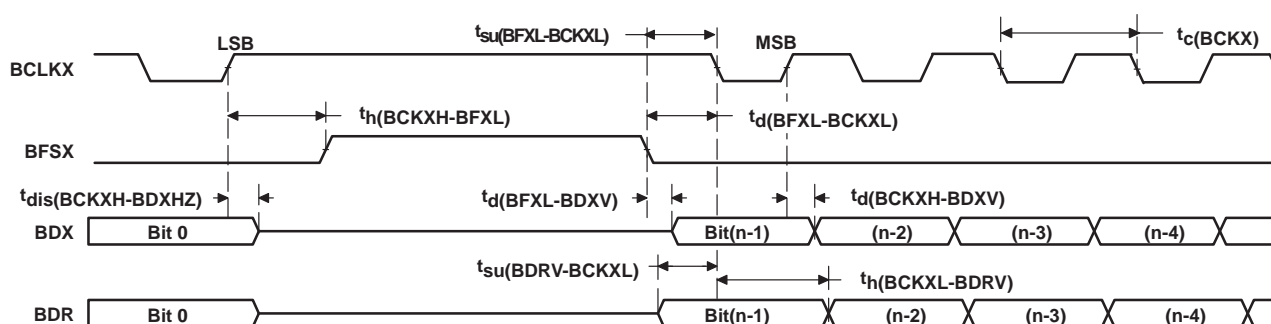


Figure 5–26. McBSP Timing as SPI Master or Slave: CLKSTP = 11b, CLKXP = 1

## 5.14 Host-Port Interface Timing

### 5.14.1 HPI8 Mode

Table 5–31 and Table 5–32 assume testing over recommended operating conditions and  $H = 0.5t_{c(CO)}$  (see Figure 5–27 through Figure 5–30). In the following tables, DS refers to the logical OR of  $\overline{HCS}$ ,  $\overline{HDS1}$ , and  $\overline{HDS2}$ . HD refers to any of the HPI data bus pins (HD0, HD1, HD2, etc.). HAD stands for  $\overline{HCNTL0}$ ,  $\overline{HCNTL1}$ , and  $\overline{HR/W}$ .

**Table 5–31. HPI8 Mode Timing Requirements†‡§**

		MIN	MAX	UNIT
$t_{su}(HBV-DSL)$	Setup time, HBIL valid before DS low	5		ns
$t_h(DSL-HBV)$	Hold time, HBIL valid after DS low	5		ns
$t_{su}(HSL-DSL)$	Setup time, $\overline{HAS}$ low before DS low	5		ns
$t_w(DSL)$	Pulse duration, DS low	20		ns
$t_w(DSH)$	Pulse duration, DS high	10		ns
$t_{su}(HDV-DSH)$	Setup time, HDx valid before DS high, HPI write	5		ns
$t_h(DSH-HDV)W$	Hold time, HDx valid after DS high, HPI write	5		ns

† DS refers to the logical OR of  $\overline{HCS}$ ,  $\overline{HDS1}$ , and  $\overline{HDS2}$ .

‡ HDx refers to any of the HPI data bus pins (HD0, HD1, HD2, etc.).

§ GPIO refers to the HD pins when they are configured as general-purpose input/outputs.

Table 5–32. HPI8 Mode Switching Characteristics†‡§¶

PARAMETER		MIN	MAX	UNIT
$t_{en}(DSL-HD)$	Enable time, HD driven from DS low	2	19	ns
$t_d(DSL-HDV1)$	Delay time, DS low to HDx valid for first byte of an HPI read	Case 1a: Memory accesses when DMAC is active in 16-bit mode and $t_w(DSH) < 18H$	$18H+19 - t_w(DSH)$	ns
		Case 1b: Memory accesses when DMAC is active in 16-bit mode and $t_w(DSH) \geq 18H$	19	
		Case 1c: Memory access when DMAC is active in 32-bit mode and $t_w(DSH) < 26H$	$26H+19 - t_w(DSH)$	
		Case 1d: Memory access when DMAC is active in 32-bit mode and $t_w(DSH) \geq 26H$	19	
		Case 2a: Memory accesses when DMAC is inactive and $t_w(DSH) < 10H$	$10H+19 - t_w(DSH)$	
		Case 2b: Memory accesses when DMAC is inactive and $t_w(DSH) \geq 10H$	19	
		Case 3: Register accesses	19	
$t_d(DSL-HDV2)$	Delay time, DS low to HDx valid for second byte of an HPI read		19	ns
$t_h(DSH-HDV)R$	Hold time, HDx valid after DS high, for a HPI read	3	5	ns
$t_v(HYH-HDV)$	Valid time, HDx valid after HRDY high		5	
$t_d(DSH-HYL)$	Delay time, DS high to HRDY low (see Note 1)		10	ns
$t_d(DSH-HYH)$	Delay time, DS high to HRDY high	Case 1a: Memory accesses when DMAC is active in 16-bit mode	$18H+10$	ns
		Case 1b: Memory accesses when DMAC is active in 32-bit mode	$26H+10$	ns
		Case 2: Memory accesses when DMAC is inactive	$10H+10$	ns
		Case 3: Write accesses to HPIC register (see Note 2)	$6H+10$	
$t_d(HCS-HRDY)$	Delay time, $\overline{HCS}$ low/high to HRDY low/high		15	ns
$t_d(COH-HYH)$	Delay time, CLKOUT high to HRDY high		2	ns
$t_d(COH-HTX)$	Delay time, CLKOUT high to $\overline{HINT}$ change		5	ns

NOTES: 1. The HRDY output is always high when the  $\overline{HCS}$  input is high, regardless of DS timings.

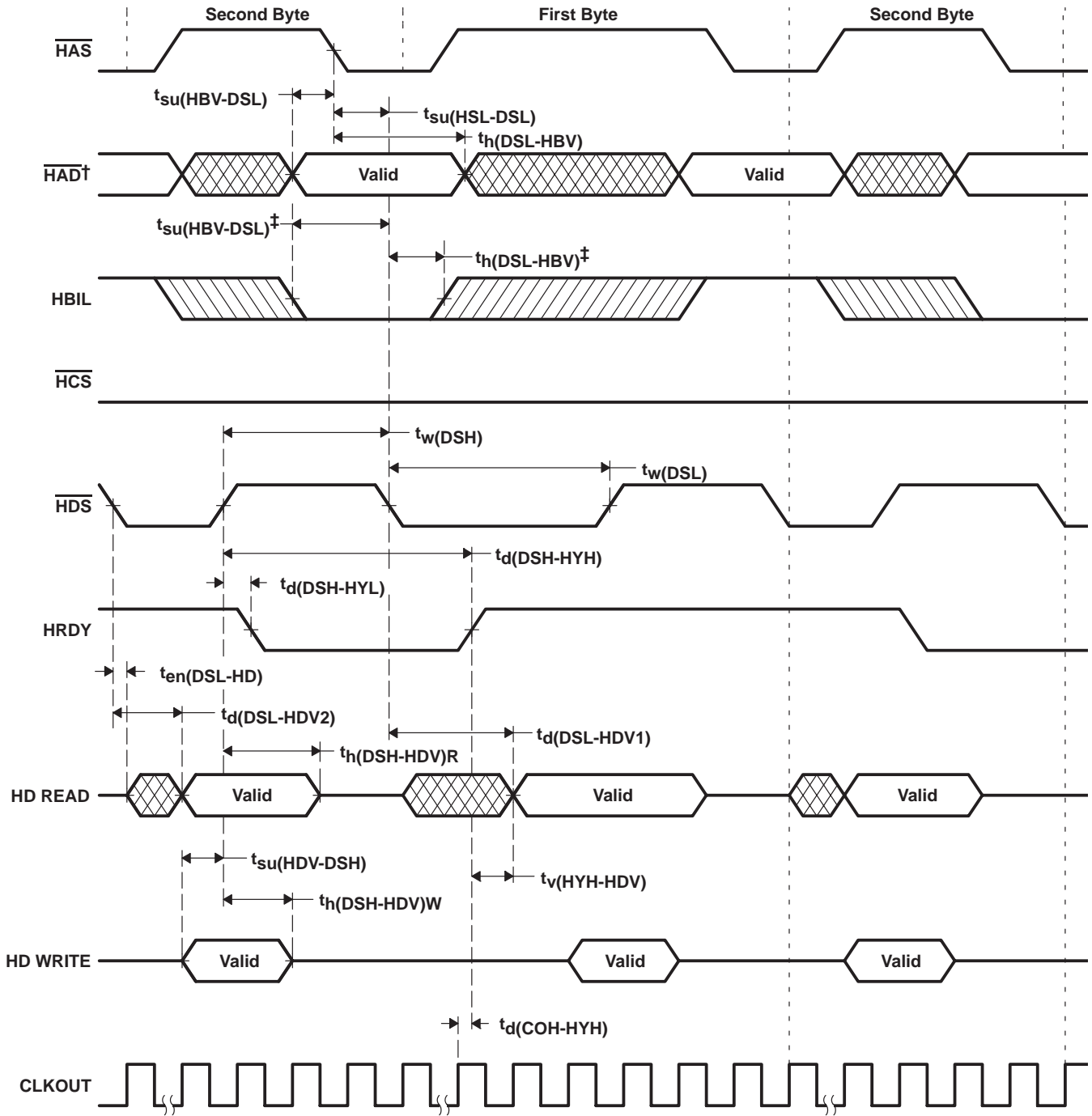
2. This timing applies when writing a one to the DSPINT bit or HINT bit of the HPIC register. All other writes to the HPIC occur asynchronously, and do not cause HRDY to be deasserted.

† DS refers to the logical OR of HCS, HDS1, and HDS2.

‡ HDx refers to any of the HPI data bus pins (HD0, HD1, HD2, etc.).

§ DMAC stands for direct memory access (DMA) controller. The HPI8 shares the internal DMA bus with the DMAC, thus HPI8 access times are affected by DMAC activity.

¶ GPIO refers to the HD pins when they are configured as general-purpose input/outputs.



† HAD refers to HCNTL0, HCNTL1, and HR/W.  
 ‡ When HAS is not used (HAS always high)

Figure 5–27. Using HDS to Control Accesses (HCS Always Low)



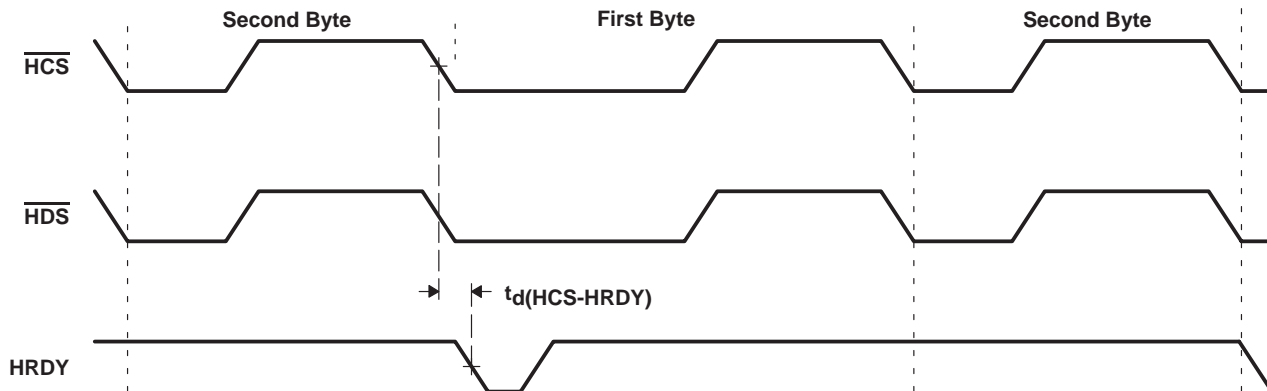


Figure 5-28. Using  $\overline{\text{HCS}}$  to Control Accesses

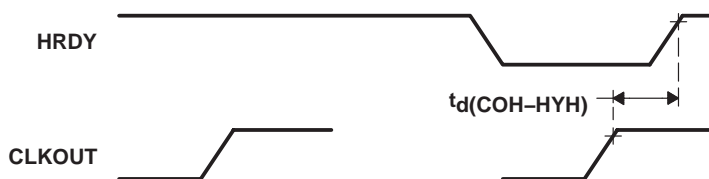


Figure 5-29.  $\text{HRDY}$  Relative to  $\text{CLKOUT}$

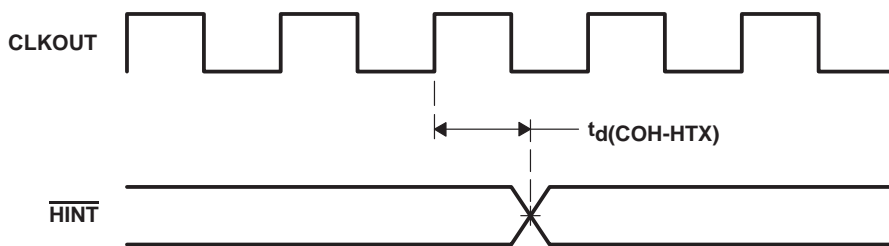


Figure 5-30.  $\overline{\text{HINT}}$  Timing

### 5.14.2 HPI16 Mode

Table 5–33 and Table 5–34 assume testing over recommended operating conditions and  $H = 0.5t_{c(CO)}$  (see Figure 5–31 through Figure 5–32). In the following tables, DS refers to the logical OR of  $\overline{HCS}$ ,  $\overline{HDS1}$ , and  $\overline{HDS2}$ , and HD refers to any of the HPI data bus pins (HD0, HD1, HD2, etc.). These timings are shown assuming that  $\overline{HDS}$  is the signal controlling the transfer. See the *TMS320C54x DSP Reference Set, Volume 5: Enhanced Peripherals* (literature number SPRU302) for additional information.

**Table 5–33. HPI16 Mode Timing Requirements**

		MIN	MAX	UNIT	
$t_{su}(HBV-DSL)$	Setup time, HAD valid before DS falling edge <sup>†‡</sup>	5		ns	
$t_h(DSL-HBV)$	Hold time, HAD valid after DS falling edge <sup>†‡</sup>	5		ns	
$t_{su}(HAV-DSL)$	Setup time, HAD valid before DS falling edge <sup>†</sup>	-4H+3		ns	
$t_h(DSH-HAV)$	Hold time, address valid after DS rising edge <sup>†</sup>	1		ns	
$t_{su}(HDV-DSH)$	Setup time, Dx valid before DS high (HPI write)	3		ns	
$t_h(DSH-HDV)W$	Hold time, Dx valid after DS high (HPI write)	2		ns	
$t_w(DSL)$	Pulse duration, DS low <sup>†</sup>	20		ns	
$t_w(DSH)$	Pulse duration, DS high <sup>†</sup>	10		ns	
$t_c(DSH-DSH)$	Cycle time, DS rising edge to next DS rising edge <sup>†</sup>	Nonmultiplexed mode (no increment) with no DMA activity.		12H	ns
	(Minimum timings represent WRITES while maximum timings represent READs)	Nonmultiplexed mode (no increment) with 16-bit DMA activity.		20H	ns

<sup>†</sup> DS refers to the logical OR of  $\overline{HCS}$  and  $\overline{HDS1}$  and  $\overline{HDS2}$ .

<sup>‡</sup> Dx refers to any of the HPI data bus pins (D0, D1, D2, etc.).

Table 5–34. HPI16 Mode Switching Characteristics†‡§¶

PARAMETER		MIN	MAX	UNIT
$t_{en}(DSL-HD)$	Enable time, Dx driven from DS low	6	19	ns
$t_d(DSL-HDV1)$	Delay time, DS low to Dx valid for an HPI read	Case 1a: Memory accesses when DMAC is active in 16-bit mode and $t_w(DSH) < 18H$	$18H+19 - t_w(DSH)$	ns
		Case 1b: Memory accesses when DMAC is active in 16-bit mode and $t_w(DSH) \geq 18H$	19	
		Case 2a: Memory accesses when DMAC is inactive and $t_w(DSH) < 10H$	$10H+19 - t_w(DSH)$	
		Case 2b: Memory accesses when DMAC is inactive and $t_w(DSH) \geq 10H$	19	
		Case 3: Register accesses	19	
$t_h(DSH-HDV)R$	Hold time, Dx valid after DS rising edge, read	1	8	ns
$t_v(HYH-HDV)$	Valid time, Dx valid before HRDY rising edge	0	6	ns
$t_d(DSH-HYL)$	Delay time, DS or $\overline{HCS}$ high to HRDY low		10	ns
$t_d(DSH-HYH)$	Delay time, DS high to HRDY high (writes and autoincrement reads)	Case 1: Memory access when DMAC is active in 16-bit mode	$18H+10$	ns
		Case 2: Memory access when DMAC is inactive	$10H+10$	
$t_d(DSL-HYL)$	Delay time, HDS or $\overline{HCS}$ low/high to HRDY low/high		10	ns
$t_d(COH-HYH)$	Delay time, CLKOUT high to HRDY high		2	ns

NOTE: The HRDY output is always high when the  $\overline{HCS}$  input is high, regardless of DS timings.

† DS refers to the logical OR of  $\overline{HCS}$ , HDS1, or HDS2.

‡ Dx refers to any of the DPI data bus pins (D0, D1, D2, etc.).

§ DMAC stands for direct memory access (DMA) controller. The HPI16 shares the internal DMA bus with the DMAC, thus HPI16 access times are affected by DMAC activity.

¶ GPIO refers to the HD pins when they are configured as general-purpose input/outputs.

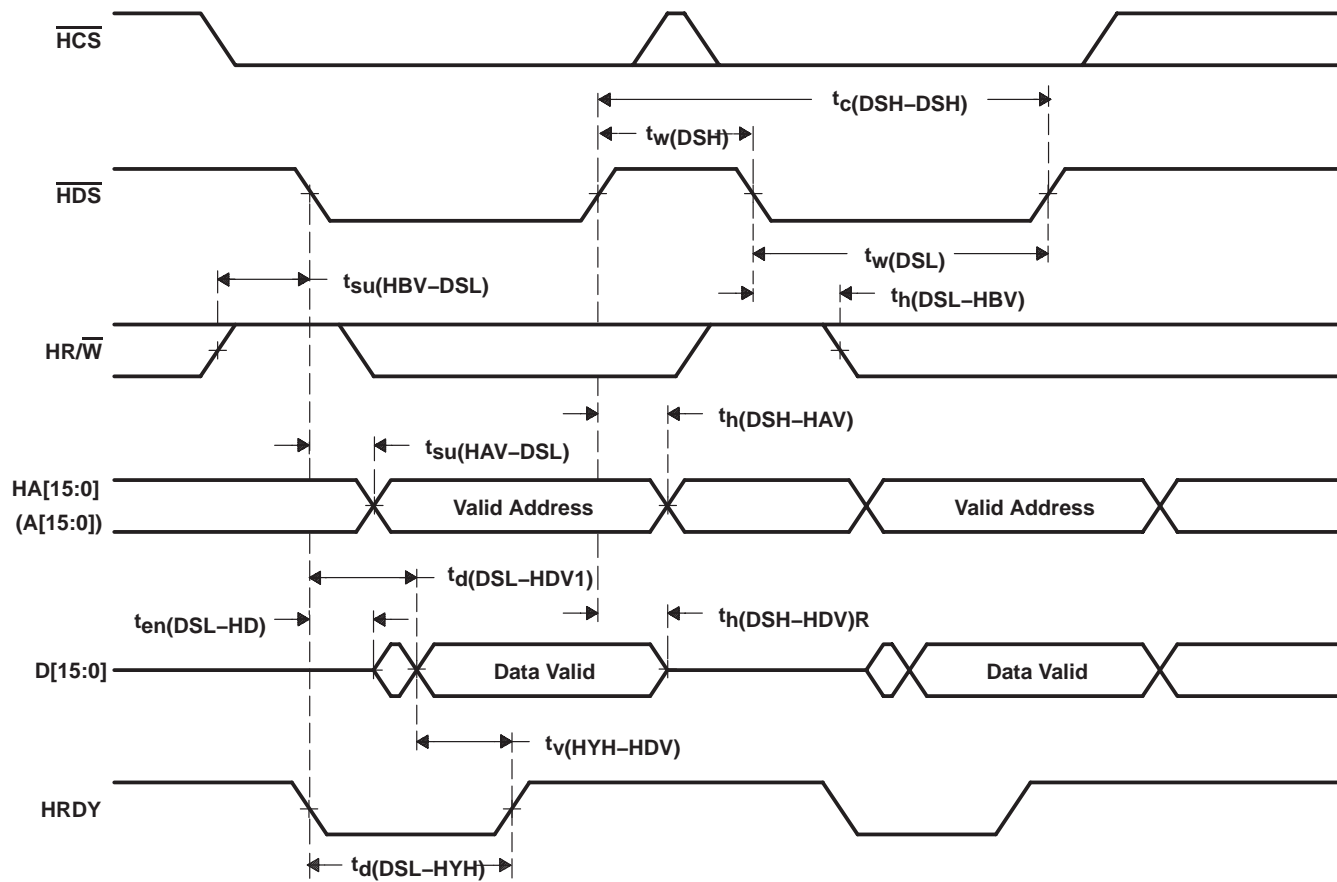


Figure 5-31. Nonmultiplexed Read Timings

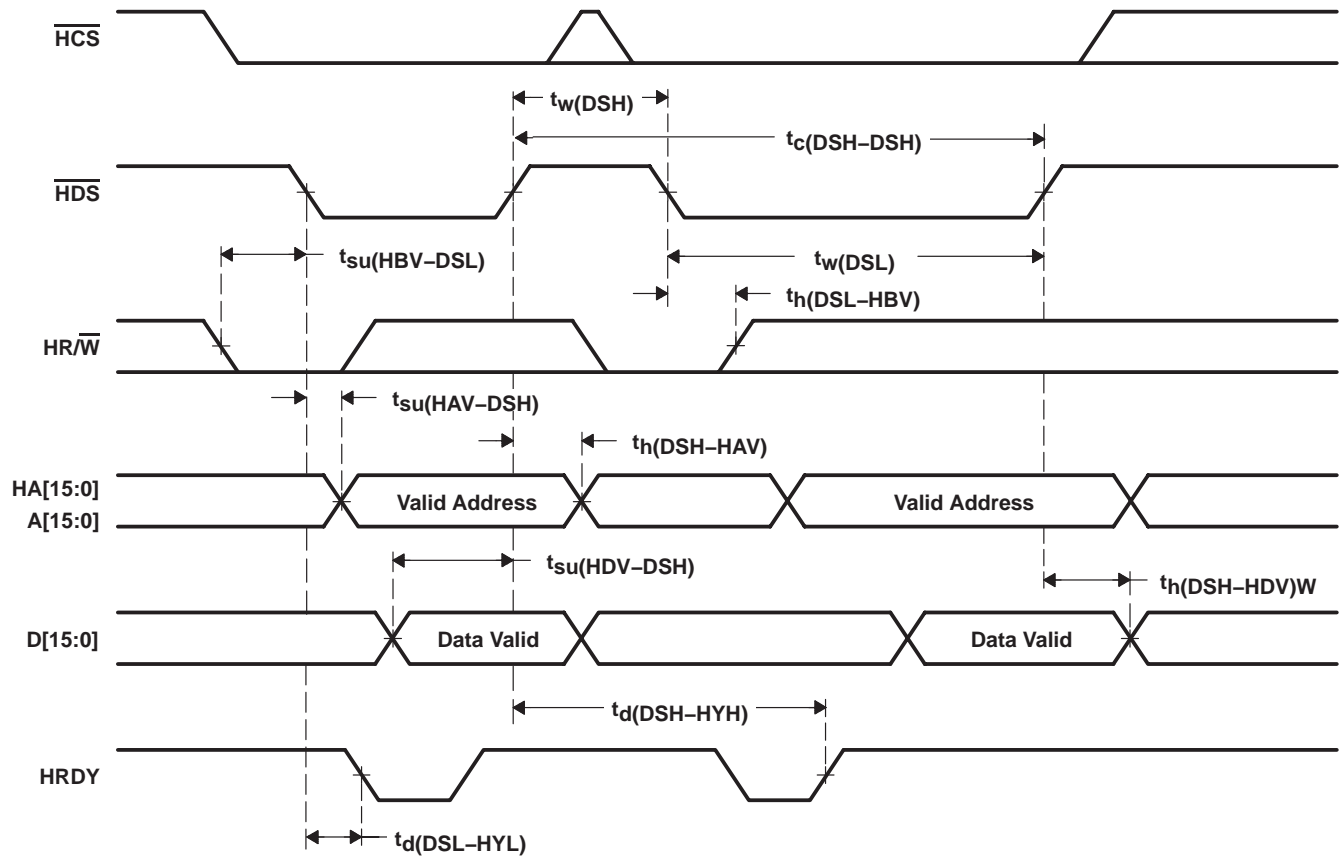


Figure 5-32. Nonmultiplexed Write Timings

## 5.15 GPIO Timing Requirements

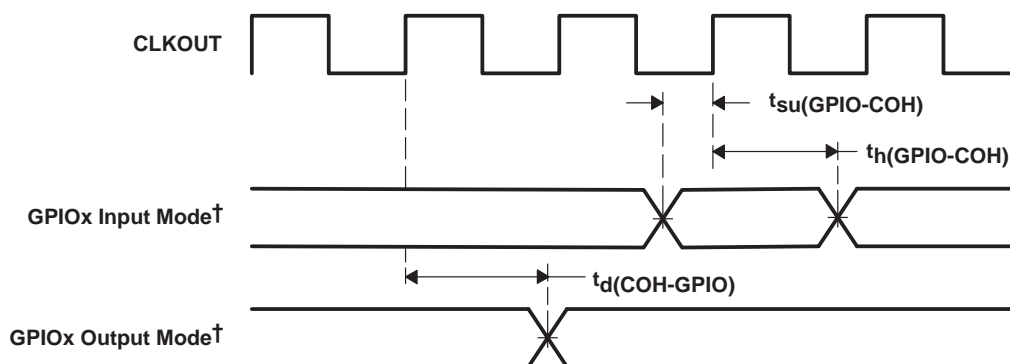
Table 5–35 to Table 5–36 assume testing over recommended operating conditions (see Figure 5–33).

**Table 5–35. GPIO Timing Requirements**

		MIN	MAX	UNIT
$t_{su}(GPIO-COH)$	Setup time, GPIOx input valid before CLKOUT high, GPIOx configured as general-purpose input.	7		ns
$t_h(GPIO-COH)$	Hold time, GPIOx input valid after CLKOUT high, GPIOx configured as general-purpose input.	0		ns

**Table 5–36. GPIO Switching Characteristics**

PARAMETER		MIN	MAX	UNIT
$t_d(COH-GPIO)$	Delay time, CLKOUT high to GPIOx output change. GPIOx configured as general-purpose output.	0	6	ns



† GPIOx refers to HD0, HD1, HD2, ...HD7, when the HD bus is configured for general-purpose input/output (I/O).

**Figure 5–33. GPIOx† Timings**

## 6 Mechanical Data

### 6.1 Package Thermal Resistance Characteristics

Table 6–1 provides the thermal resistance characteristics for the recommended package types used on the TMS320VC5409 DSP.

**Table 6–1. Thermal Resistance Characteristics**

PARAMETER	GGU PACKAGE	PGE PACKAGE	UNIT
$R_{\theta JA}$	38	56	°C/W
$R_{\theta JC}$	5	5	°C/W

### 6.2 Packaging Information

The following packaging information reflects the most current released data available for the designated device(s). This data is subject to change without notice and without revision of this document.

**PACKAGING INFORMATION**

Orderable Device	Status (1)	Package Type	Package Drawing	Pins	Package Qty	Eco Plan (2)	Lead/Ball Finish (6)	MSL Peak Temp (3)	Op Temp (°C)	Device Marking (4/5)	Samples
TMS320VC5409GGU-80	OBSOLETE	BGA MICROSTAR	GGU	144		Green (RoHS & no Sb/Br)	SNPB	Level-1-260C-UNLIM	-40 to 100	DVC5409GGU 80	
TMS320VC5409GGU100	OBSOLETE	BGA MICROSTAR	GGU	144		TBD	SNPB	Level-3-220C-168 HR	-40 to 100	DVC5409GGU 100	
TMS320VC5409PGE-80	OBSOLETE	LQFP	PGE	144		Green (RoHS & no Sb/Br)	CU NIPDAU	Level-1-260C-UNLIM	-40 to 100	PGE-80 TMS320VC5409	
TMS320VC5409PGE100	OBSOLETE	LQFP	PGE	144		Green (RoHS & no Sb/Br)	CU NIPDAU	Level-1-260C-UNLIM	-40 to 100	PGE100 TMS320VC5409	
TMS320VC5409ZGU-80	OBSOLETE	BGA MICROSTAR	ZGU	144		Green (RoHS & no Sb/Br)	SNAGCU	Level-3-260C-168 HR	-40 to 100	DVC5409ZGU -80	
TMS320VC5409ZGU100	OBSOLETE	BGA MICROSTAR	ZGU	144		Green (RoHS & no Sb/Br)	SNAGCU	Level-3-260C-168 HR	-40 to 100	DVC5409ZGU 100	
TMS320VC5409ZGUR80	OBSOLETE	BGA MICROSTAR	ZGU	144		TBD	Call TI	Call TI	-40 to 100	DVC5409ZGU -80	

(1) The marketing status values are defined as follows:

**ACTIVE:** Product device recommended for new designs.

**LIFEBUY:** TI has announced that the device will be discontinued, and a lifetime-buy period is in effect.

**NRND:** Not recommended for new designs. Device is in production to support existing customers, but TI does not recommend using this part in a new design.

**PREVIEW:** Device has been announced but is not in production. Samples may or may not be available.

**OBSOLETE:** TI has discontinued the production of the device.

(2) Eco Plan - The planned eco-friendly classification: Pb-Free (RoHS), Pb-Free (RoHS Exempt), or Green (RoHS & no Sb/Br) - please check <http://www.ti.com/productcontent> for the latest availability information and additional product content details.

**TBD:** The Pb-Free/Green conversion plan has not been defined.

**Pb-Free (RoHS):** TI's terms "Lead-Free" or "Pb-Free" mean semiconductor products that are compatible with the current RoHS requirements for all 6 substances, including the requirement that lead not exceed 0.1% by weight in homogeneous materials. Where designed to be soldered at high temperatures, TI Pb-Free products are suitable for use in specified lead-free processes.

**Pb-Free (RoHS Exempt):** This component has a RoHS exemption for either 1) lead-based flip-chip solder bumps used between the die and package, or 2) lead-based die adhesive used between the die and leadframe. The component is otherwise considered Pb-Free (RoHS compatible) as defined above.

**Green (RoHS & no Sb/Br):** TI defines "Green" to mean Pb-Free (RoHS compatible), and free of Bromine (Br) and Antimony (Sb) based flame retardants (Br or Sb do not exceed 0.1% by weight in homogeneous material)

(3) MSL, Peak Temp. - The Moisture Sensitivity Level rating according to the JEDEC industry standard classifications, and peak solder temperature.

(4) There may be additional marking, which relates to the logo, the lot trace code information, or the environmental category on the device.



<sup>(5)</sup> Multiple Device Markings will be inside parentheses. Only one Device Marking contained in parentheses and separated by a "-" will appear on a device. If a line is indented then it is a continuation of the previous line and the two combined represent the entire Device Marking for that device.

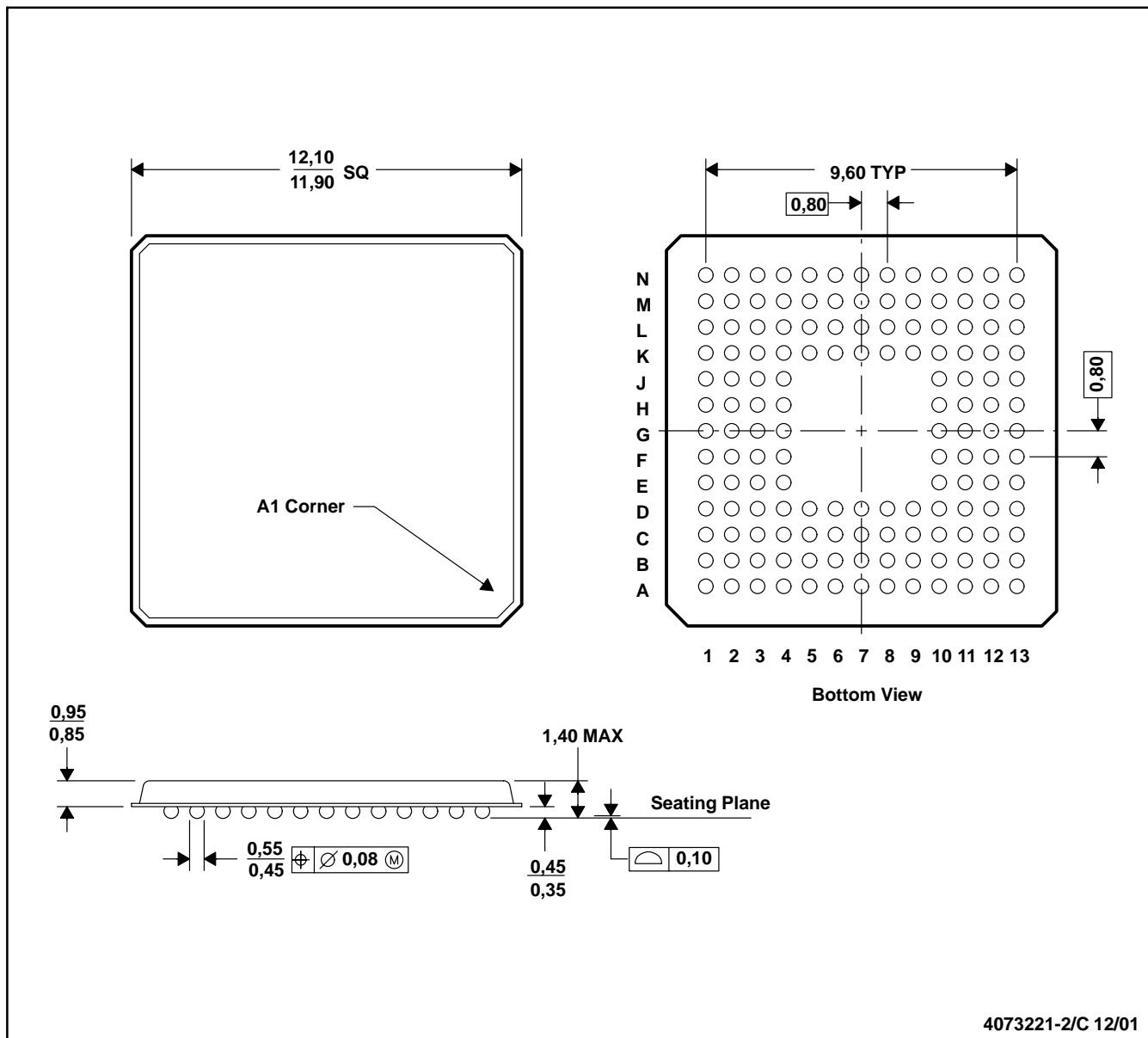
<sup>(6)</sup> Lead/Ball Finish - Orderable Devices may have multiple material finish options. Finish options are separated by a vertical ruled line. Lead/Ball Finish values may wrap to two lines if the finish value exceeds the maximum column width.

**Important Information and Disclaimer:**The information provided on this page represents TI's knowledge and belief as of the date that it is provided. TI bases its knowledge and belief on information provided by third parties, and makes no representation or warranty as to the accuracy of such information. Efforts are underway to better integrate information from third parties. TI has taken and continues to take reasonable steps to provide representative and accurate information but may not have conducted destructive testing or chemical analysis on incoming materials and chemicals. TI and TI suppliers consider certain information to be proprietary, and thus CAS numbers and other limited information may not be available for release.

In no event shall TI's liability arising out of such information exceed the total purchase price of the TI part(s) at issue in this document sold by TI to Customer on an annual basis.

GGU (S-PBGA-N144)

PLASTIC BALL GRID ARRAY



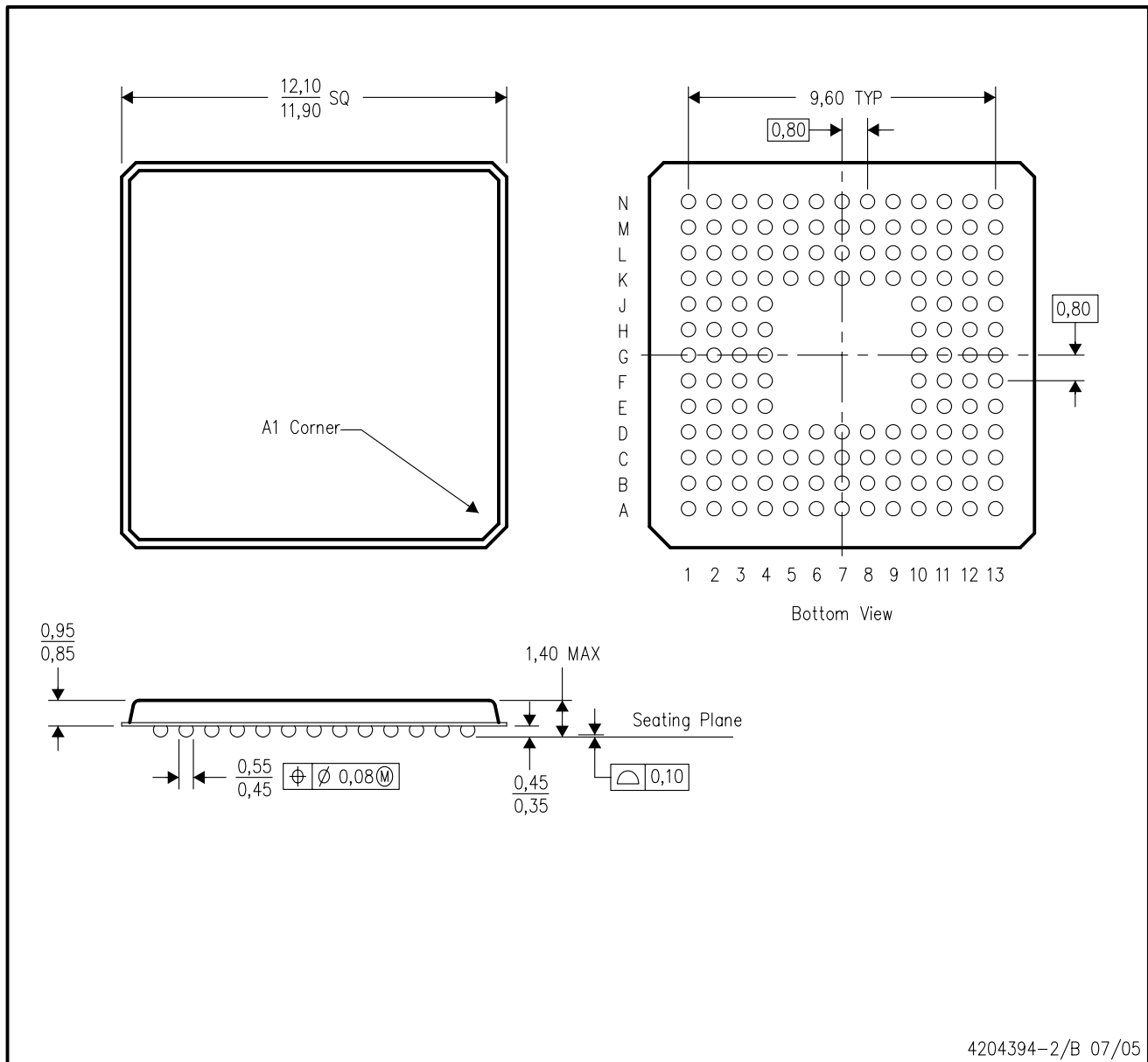
- NOTES: A. All linear dimensions are in millimeters.  
 B. This drawing is subject to change without notice  
 C. MicroStar BGA™ configuration

MicroStar BGA is a trademark of Texas Instruments Incorporated.



ZGU (S-PBGA-N144)

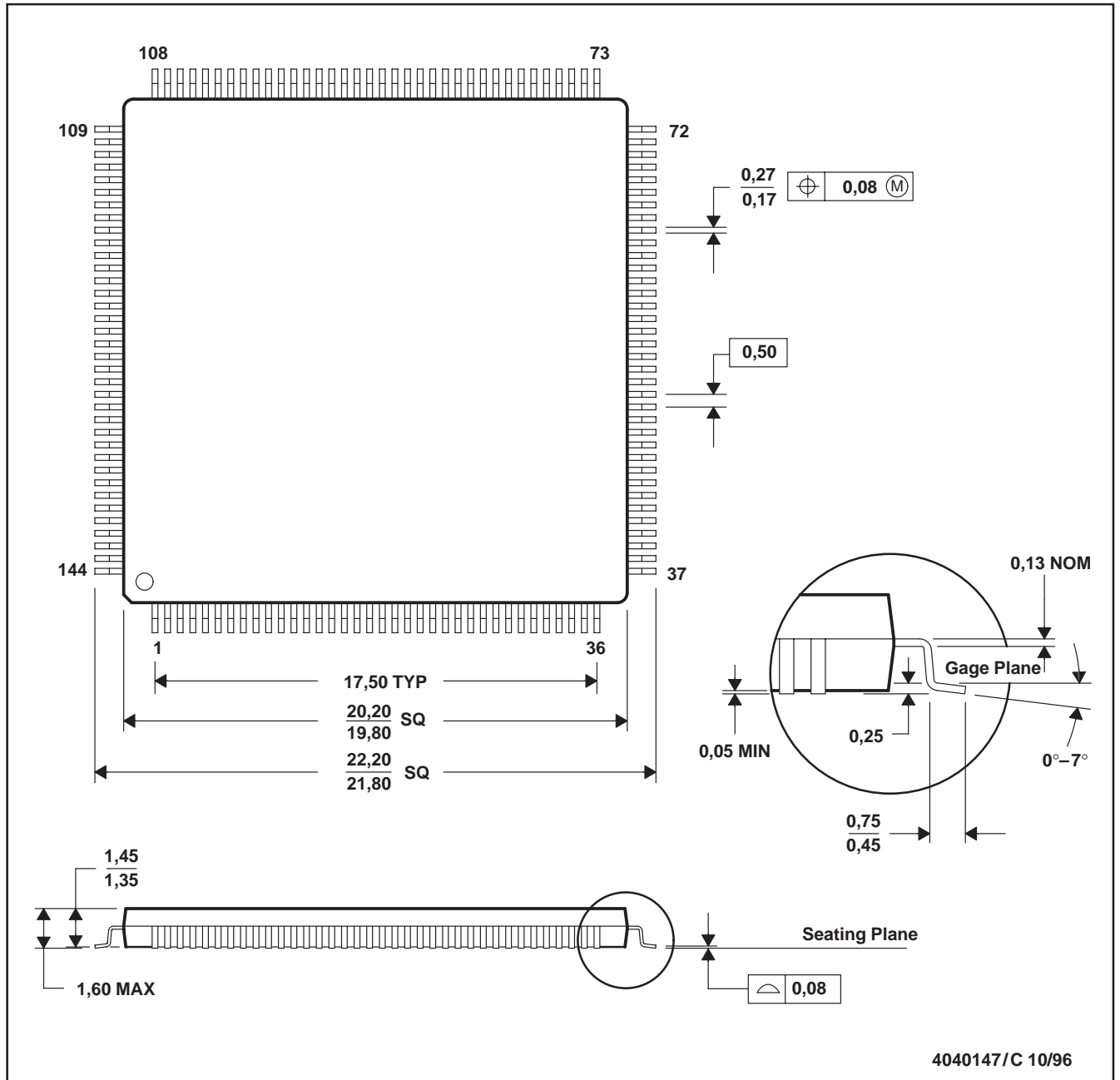
PLASTIC BALL GRID ARRAY



- NOTES:
- A. All linear dimensions are in millimeters.
  - B. This drawing is subject to change without notice.
  - C. Micro Star BGA configuration
  - D. This is a lead-free solder ball design.

PGE (S-PQFP-G144)

PLASTIC QUAD FLATPACK



- NOTES: A. All linear dimensions are in millimeters.  
 B. This drawing is subject to change without notice.  
 C. Falls within JEDEC MS-026

## IMPORTANT NOTICE

Texas Instruments Incorporated and its subsidiaries (TI) reserve the right to make corrections, enhancements, improvements and other changes to its semiconductor products and services per JESD46, latest issue, and to discontinue any product or service per JESD48, latest issue. Buyers should obtain the latest relevant information before placing orders and should verify that such information is current and complete. All semiconductor products (also referred to herein as "components") are sold subject to TI's terms and conditions of sale supplied at the time of order acknowledgment.

TI warrants performance of its components to the specifications applicable at the time of sale, in accordance with the warranty in TI's terms and conditions of sale of semiconductor products. Testing and other quality control techniques are used to the extent TI deems necessary to support this warranty. Except where mandated by applicable law, testing of all parameters of each component is not necessarily performed.

TI assumes no liability for applications assistance or the design of Buyers' products. Buyers are responsible for their products and applications using TI components. To minimize the risks associated with Buyers' products and applications, Buyers should provide adequate design and operating safeguards.

TI does not warrant or represent that any license, either express or implied, is granted under any patent right, copyright, mask work right, or other intellectual property right relating to any combination, machine, or process in which TI components or services are used. Information published by TI regarding third-party products or services does not constitute a license to use such products or services or a warranty or endorsement thereof. Use of such information may require a license from a third party under the patents or other intellectual property of the third party, or a license from TI under the patents or other intellectual property of TI.

Reproduction of significant portions of TI information in TI data books or data sheets is permissible only if reproduction is without alteration and is accompanied by all associated warranties, conditions, limitations, and notices. TI is not responsible or liable for such altered documentation. Information of third parties may be subject to additional restrictions.

Resale of TI components or services with statements different from or beyond the parameters stated by TI for that component or service voids all express and any implied warranties for the associated TI component or service and is an unfair and deceptive business practice. TI is not responsible or liable for any such statements.

Buyer acknowledges and agrees that it is solely responsible for compliance with all legal, regulatory and safety-related requirements concerning its products, and any use of TI components in its applications, notwithstanding any applications-related information or support that may be provided by TI. Buyer represents and agrees that it has all the necessary expertise to create and implement safeguards which anticipate dangerous consequences of failures, monitor failures and their consequences, lessen the likelihood of failures that might cause harm and take appropriate remedial actions. Buyer will fully indemnify TI and its representatives against any damages arising out of the use of any TI components in safety-critical applications.

In some cases, TI components may be promoted specifically to facilitate safety-related applications. With such components, TI's goal is to help enable customers to design and create their own end-product solutions that meet applicable functional safety standards and requirements. Nonetheless, such components are subject to these terms.

No TI components are authorized for use in FDA Class III (or similar life-critical medical equipment) unless authorized officers of the parties have executed a special agreement specifically governing such use.

Only those TI components which TI has specifically designated as military grade or "enhanced plastic" are designed and intended for use in military/aerospace applications or environments. Buyer acknowledges and agrees that any military or aerospace use of TI components which have **not** been so designated is solely at the Buyer's risk, and that Buyer is solely responsible for compliance with all legal and regulatory requirements in connection with such use.

TI has specifically designated certain components as meeting ISO/TS16949 requirements, mainly for automotive use. In any case of use of non-designated products, TI will not be responsible for any failure to meet ISO/TS16949.

### Products

Audio	<a href="http://www.ti.com/audio">www.ti.com/audio</a>
Amplifiers	<a href="http://amplifier.ti.com">amplifier.ti.com</a>
Data Converters	<a href="http://dataconverter.ti.com">dataconverter.ti.com</a>
DLP® Products	<a href="http://www.dlp.com">www.dlp.com</a>
DSP	<a href="http://dsp.ti.com">dsp.ti.com</a>
Clocks and Timers	<a href="http://www.ti.com/clocks">www.ti.com/clocks</a>
Interface	<a href="http://interface.ti.com">interface.ti.com</a>
Logic	<a href="http://logic.ti.com">logic.ti.com</a>
Power Mgmt	<a href="http://power.ti.com">power.ti.com</a>
Microcontrollers	<a href="http://microcontroller.ti.com">microcontroller.ti.com</a>
RFID	<a href="http://www.ti-rfid.com">www.ti-rfid.com</a>
OMAP Applications Processors	<a href="http://www.ti.com/omap">www.ti.com/omap</a>
Wireless Connectivity	<a href="http://www.ti.com/wirelessconnectivity">www.ti.com/wirelessconnectivity</a>

### Applications

Automotive and Transportation	<a href="http://www.ti.com/automotive">www.ti.com/automotive</a>
Communications and Telecom	<a href="http://www.ti.com/communications">www.ti.com/communications</a>
Computers and Peripherals	<a href="http://www.ti.com/computers">www.ti.com/computers</a>
Consumer Electronics	<a href="http://www.ti.com/consumer-apps">www.ti.com/consumer-apps</a>
Energy and Lighting	<a href="http://www.ti.com/energy">www.ti.com/energy</a>
Industrial	<a href="http://www.ti.com/industrial">www.ti.com/industrial</a>
Medical	<a href="http://www.ti.com/medical">www.ti.com/medical</a>
Security	<a href="http://www.ti.com/security">www.ti.com/security</a>
Space, Avionics and Defense	<a href="http://www.ti.com/space-avionics-defense">www.ti.com/space-avionics-defense</a>
Video and Imaging	<a href="http://www.ti.com/video">www.ti.com/video</a>

### TI E2E Community

[e2e.ti.com](http://e2e.ti.com)