

# HA17358B Series

## Dual Operational Amplifier

REA03D0001-0100

Rev.1.00

Dec 25, 2006

### Description

HA17358B is dual operational amplifiers that provide high gain and internal phase compensation, with single power supply. Operation from split power supply is also possible and the low power supply current drain is independent of the magnitude of the power supply voltages. They can be widely applied to control equipment and to general use.

### Features

- Wide range of supply voltage  
Single supply: 3 V to 36 V, Dual supplies:  $\pm 1.5$  V to  $\pm 18$  V
- Wide range of common mode voltage, and possible to operate with an input about 0 V, and output around 0 V is available.
- Internally frequency compensated for unity gain.
- Common mode input voltage range includes ground.
- Package outline available in Pb free lead frame:  
DP-8  
SOP-8 (JEITA)  
SOP-8 (JEDEC)

### Applications

- Battery charger
- Cordless telephone
- Switching power supply

### Ordering Information

Type No.	Application	Package Code (Package Name)
HA17358B	Commercial use	PRDP0008AF-B (DP-8FV)
HA17358BF		PRSP0008DE-B (FP-8DGV)
HA17358BRP		PRSP0008DD-C (FP-8DCV)

Note: This product is designed for consumer use and not for automotive.

### Pin Arrangement

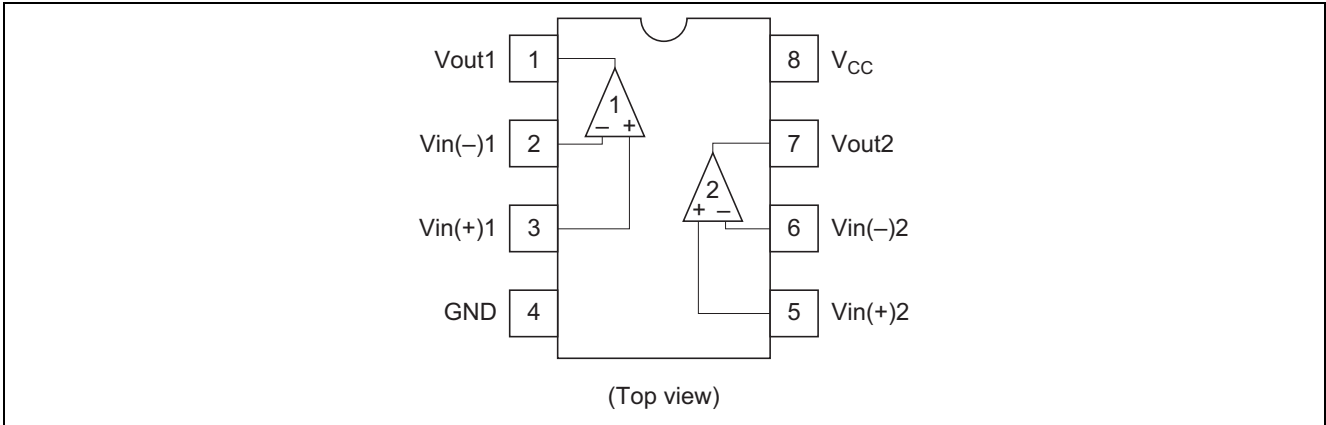

### Circuit Schematic (1/2)

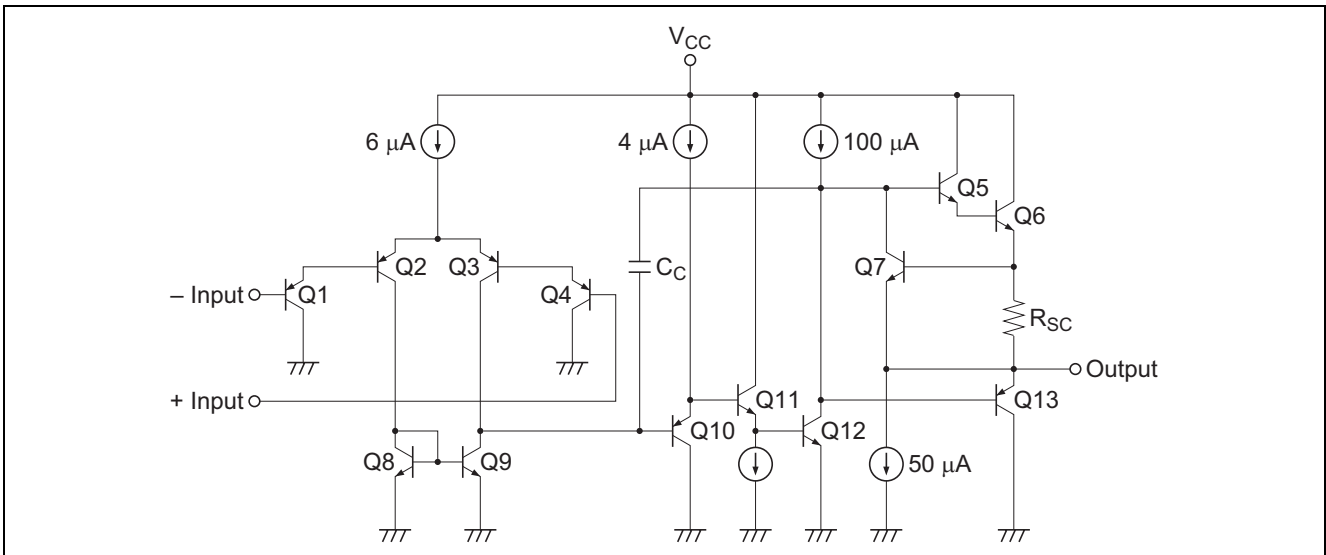

## Absolute Maximum Ratings

(Ta = 25°C)

Item	Symbol	Ratings			Unit
		HA17358B	HA17358BF	HA17358BRP	
Supply Voltage	V <sub>CC</sub>	36	36	36	V
Differential input voltage	V <sub>IN</sub> (diff)	V <sub>CC</sub>	V <sub>CC</sub>	V <sub>CC</sub>	V
Common mode input voltage	V <sub>CM</sub>	-0.3 to V <sub>CC</sub>	-0.3 to V <sub>CC</sub>	-0.3 to V <sub>CC</sub>	V
Power dissipation	P <sub>T</sub>	570 * <sup>1</sup>	385 * <sup>2</sup>	385 * <sup>2</sup>	mW
Operating temperature	Topr	-40 to +85	-40 to +85	-40 to +85	°C
Storage temperature	Tstg	-55 to +125	-55 to +125	-55 to +125	°C

Notes: 1. This is the allowable value up to Ta = 55°C. Derate by 8.3 mW/°C above that temperature.

2. These are the allowable values up to Ta = 25°C mounting in air. When it is mounted on glass epoxy board of 40 mm × 40 mm × 1.5 mm (t) with 30% wiring density, the allowable value is 570 mW up to Ta = 45°C.

If Ta > 45°C, derate by 7.14 mW/°C.

## Electrical Characteristics

(Ta = 25°C, V<sub>CC</sub> = +5 V, unless otherwise specified)

Item	Symbol	Min	Typ	Max	Unit	Test Conditions
Input offset voltage	V <sub>IO</sub>	—	2	5	mV	V <sub>O</sub> = 1.4 V, R <sub>S</sub> = 0 Ω V <sub>CC</sub> = 5 V to 30 V
Input offset current	I <sub>IO</sub>	—	5	30	nA	V <sub>CM</sub> = 0 V, I <sub>IO</sub> =  I <sub>IN(+)</sub> - I <sub>IN(-)</sub>
Input bias current	I <sub>IB</sub>	—	20	200	nA	V <sub>CM</sub> = 0 V, I <sub>IN(+)</sub> or I <sub>IN(-)</sub>
Power supply rejection ratio	PSRR	—	100	—	dB	V <sub>CC</sub> = 5 V to 30 V
Voltage gain	A <sub>V</sub>	85	100	—	dB	V <sub>CC</sub> = 15 V, R <sub>L</sub> ≥ 2 kΩ, V <sub>O</sub> = 1 V to 11 V
Common mode rejection Ratio	CMR	60	70	—	dB	DC, V <sub>CM</sub> = 0 V to (V <sub>CC</sub> - 1.5) V
Common mode input voltage range	V <sub>IR</sub>	0	—	V <sub>CC</sub> -1.5	V	V <sub>CC</sub> = 30 V
Output swing voltage	V <sub>OH</sub>	26	—	—	V	V <sub>CC</sub> = 30 V, R <sub>L</sub> = 2 kΩ
		27	28	—	V	V <sub>CC</sub> = 30 V, R <sub>L</sub> = 10 kΩ
	V <sub>OL</sub>	—	5	20	mV	V <sub>CC</sub> = 5 V, R <sub>L</sub> = 10 kΩ
Output source current	I <sub>OSOURCE</sub>	20	40	—	mA	V <sub>IN(+)</sub> = 1 V, V <sub>IN(-)</sub> = 0 V, V <sub>O</sub> = 2 V, V <sub>CC</sub> = 15 V
Output sink current	I <sub>OSINK</sub>	10	15	—	mA	V <sub>IN(-)</sub> = 1 V, V <sub>IN(+)</sub> = 0 V, V <sub>O</sub> = 2 V, V <sub>CC</sub> = 15 V
		12	50	—	μA	V <sub>IN(-)</sub> = 1 V, V <sub>IN(+)</sub> = 0 V, V <sub>O</sub> = 0.2 V, V <sub>CC</sub> = 15 V
Supply current	I <sub>CC</sub>	—	0.5	1.2	mA	R <sub>L</sub> = ∞, V <sub>CC</sub> = 5 V
		—	0.7	2	mA	R <sub>L</sub> = ∞, V <sub>CC</sub> = 30 V
Channel separation	CS	—	-120	—	dB	f = 1 kHz to 20 kHz

**Table of Graphs**

<b>Electrical Characteristics</b>		<b>Figure</b>
Input voltage	vs. Supply voltage $\pm V_{CC}$	1
Input bias current	vs. Temperature $T_a$	2
Supply current	vs. Supply voltage $\pm V_{CC}$	3
Voltage gain	vs. Supply voltage $V_{CC}$	4
Voltage gain	vs. Frequency $f$	5
Output swing voltage	vs. Frequency $f$	6
Output source current	vs. Output voltage $V_O$	7
Output sink current	vs. Output voltage $V_O$	8

Typical Characteristics Curves

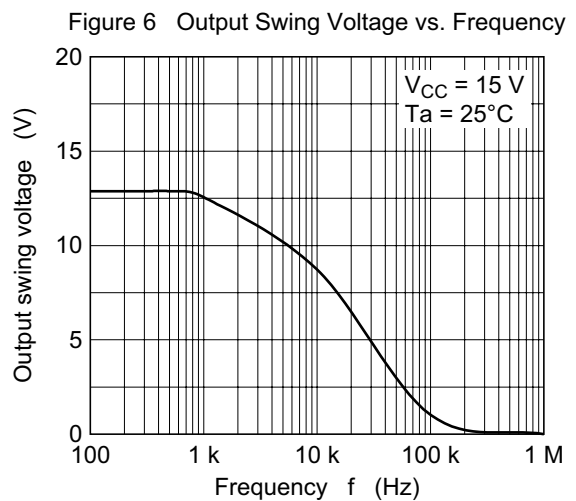
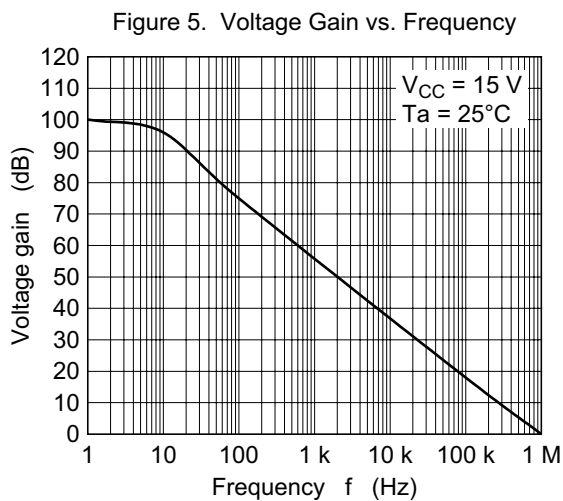
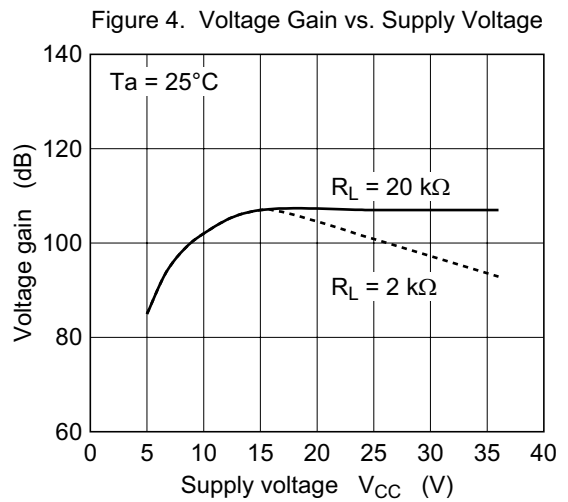
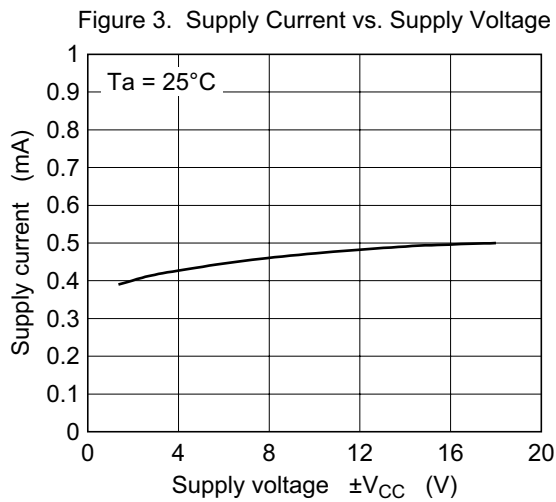
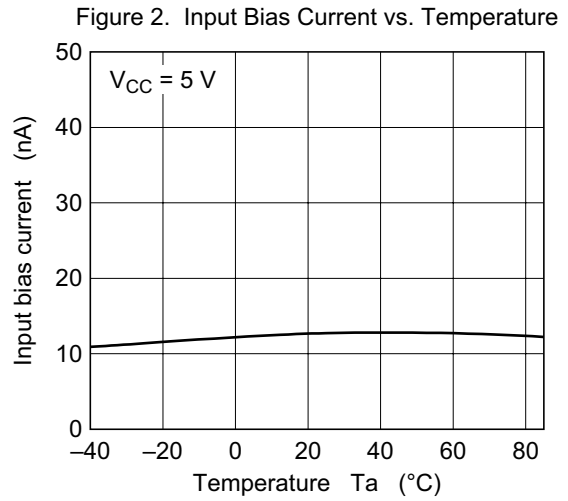
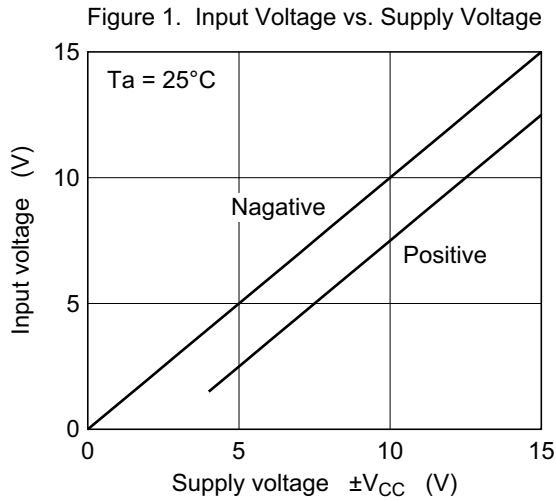

Typical Characteristics Curves (cont.)

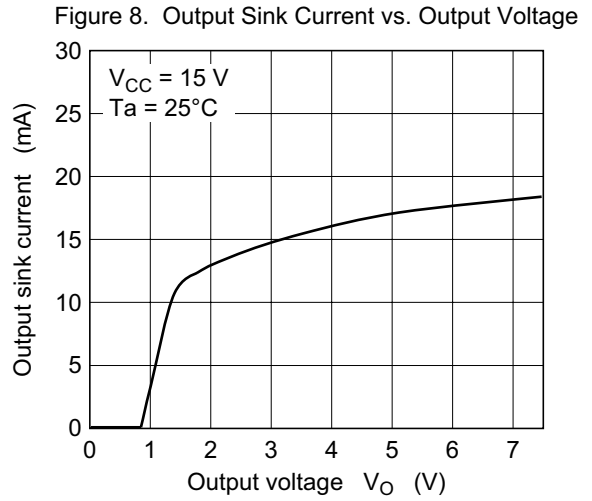
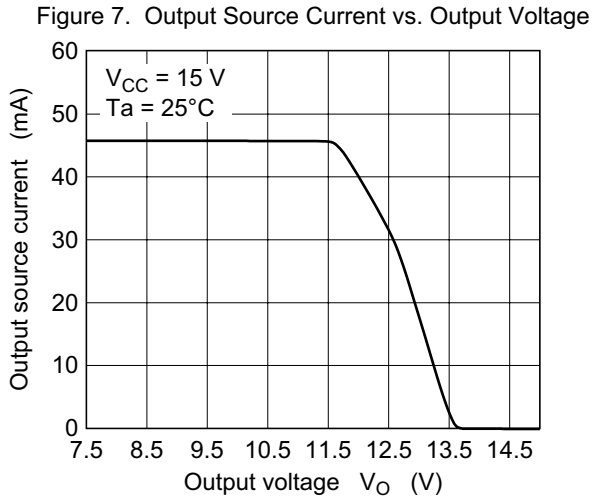

Package Dimensions

JEITA Package Code	RENESAS Code	Previous Code	MASS[Typ.]
P-DIP8-6.3x9.6-2.54	PRDP0008AF-B	DP-8FV	0.54g

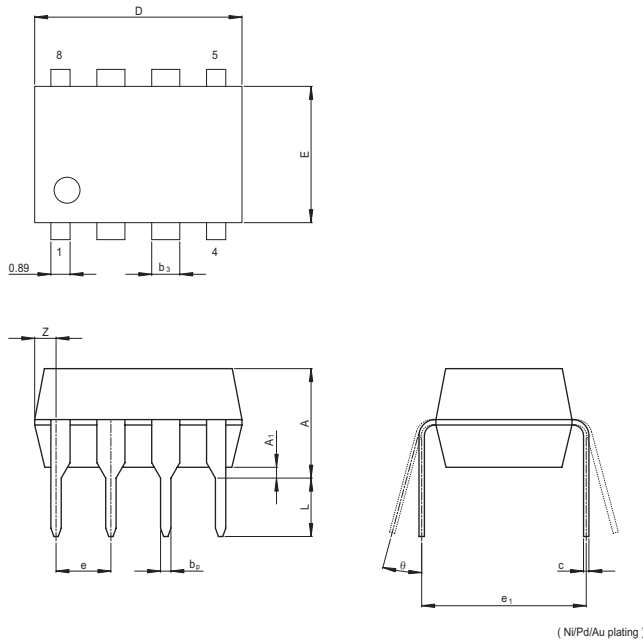

Reference Symbol	Dimension in Millimeters		
	Min	Nom	Max
e <sub>1</sub>	—	7.62	—
D	—	9.60	10.6
E	—	6.30	7.4
A	—	—	5.06
A <sub>1</sub>	0.5	—	—
b <sub>p</sub>	0.40	0.48	0.56
b <sub>3</sub>	—	1.30	—
c	0.19	0.25	0.31
θ	0°	—	15°
e	2.29	2.54	2.79
Z	—	—	1.27
L	2.54	—	—

JEITA Package Code	RENESAS Code	Previous Code	MASS[Typ.]
P-SOP8-4.4x4.85-1.27	PRSP0008DE-B	FP-8DGV	0.1g

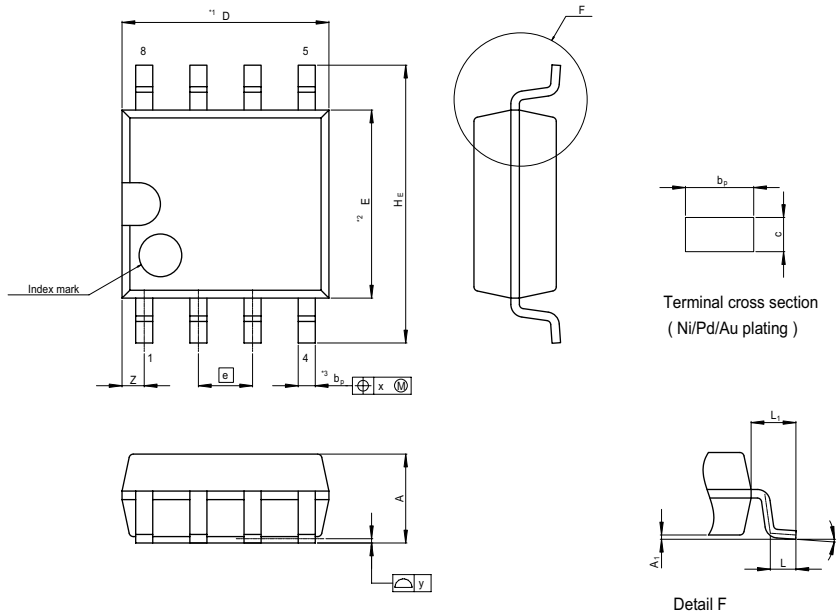

NOTE  
 1. DIMENSIONS\*\*1 (Nom)\*\*AND\*\*2\* DO NOT INCLUDE MOLD FLASH.  
 2. DIMENSION\*\*3\* DOES NOT INCLUDE TRIM OFFSET.

Reference Symbol	Dimension in Millimeters		
	Min	Nom	Max
D	—	4.85	5.25
E	—	4.4	—
A <sub>2</sub>	—	—	—
A <sub>1</sub>	0.00	0.1	0.20
A	—	—	2.03
b <sub>p</sub>	0.35	0.4	0.45
b <sub>1</sub>	—	—	—
c	0.15	0.20	0.25
c <sub>1</sub>	—	—	—
θ	0°	—	8°
H <sub>E</sub>	6.35	6.5	6.75
⊕	—	1.27	—
x	—	—	0.12
y	—	—	0.15
Z	—	—	0.75
L	0.42	0.60	0.85
L <sub>1</sub>	—	1.05	—

# HA17358B Series

JEITA Package Code	RENESAS Code	Previous Code	MASS[Typ.]
P-SOP8-3.95x4.9-1.27	PRSP0008DD-C	FP-8DCV	0.085g

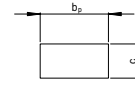
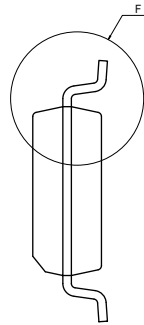
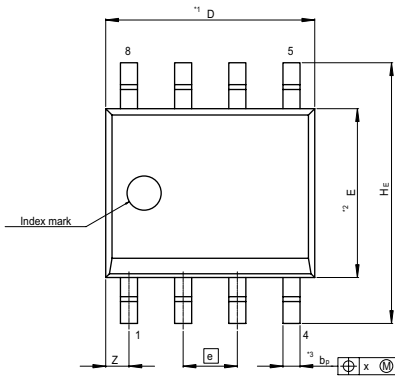

Terminal cross section  
( Ni/Pd/Au plating )

NOTE)  
1. DIMENSIONS\*\*1 (Nom)\*\*AND\*\*2"  
DO NOT INCLUDE MOLD FLASH.  
2. DIMENSION\*\*3"DOES NOT  
INCLUDE TRIM OFFSET.

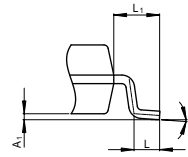
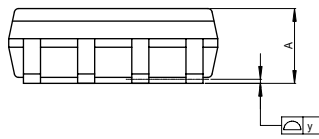

Detail F

Reference Symbol	Dimension in Millimeters		
	Min	Nom	Max
D	—	4.90	5.30
E	—	3.95	—
A <sub>2</sub>	—	—	—
A <sub>1</sub>	0.10	0.14	0.25
A	—	—	1.75
b <sub>p</sub>	0.34	0.40	0.46
b <sub>1</sub>	—	—	—
c	0.15	0.20	0.25
c <sub>1</sub>	—	—	—
$\theta$	0°	—	8°
H <sub>E</sub>	5.80	6.10	6.20
$\text{⓪}$	—	1.27	—
x	—	—	0.25
y	—	—	0.10
Z	—	—	0.75
L	0.40	0.60	1.27
L <sub>1</sub>	—	1.08	—



Notes:

1. This document is provided for reference purposes only so that Renesas customers may select the appropriate Renesas products for their use. Renesas neither makes warranties or representations with respect to the accuracy or completeness of the information contained in this document nor grants any license to any intellectual property rights or any other rights of Renesas or any third party with respect to the information in this document.
2. Renesas shall have no liability for damages or infringement of any intellectual property or other rights arising out of the use of any information in this document, including, but not limited to, product data, diagrams, charts, programs, algorithms, and application circuit examples.
3. You should not use the products or the technology described in this document for the purpose of military applications such as the development of weapons of mass destruction or for the purpose of any other military use. When exporting the products or technology described herein, you should follow the applicable export control laws and regulations, and procedures required by such laws and regulations.
4. All information included in this document such as product data, diagrams, charts, programs, algorithms, and application circuit examples, is current as of the date this document is issued. Such information, however, is subject to change without any prior notice. Before purchasing or using any Renesas products listed in this document, please confirm the latest product information with a Renesas sales office. Also, please pay regular and careful attention to additional and different information to be disclosed by Renesas such as that disclosed through our website. (<http://www.renesas.com>)
5. Renesas has used reasonable care in compiling the information included in this document, but Renesas assumes no liability whatsoever for any damages incurred as a result of errors or omissions in the information included in this document.
6. When using or otherwise relying on the information in this document, you should evaluate the information in light of the total system before deciding about the applicability of such information to the intended application. Renesas makes no representations, warranties or guaranties regarding the suitability of its products for any particular application and specifically disclaims any liability arising out of the application and use of the information in this document or Renesas products.
7. With the exception of products specified by Renesas as suitable for automobile applications, Renesas products are not designed, manufactured or tested for applications or otherwise in systems the failure or malfunction of which may cause a direct threat to human life or create a risk of human injury or which require especially high quality and reliability such as safety systems, or equipment or systems for transportation and traffic, healthcare, combustion control, aerospace and aeronautics, nuclear power, or undersea communication transmission. If you are considering the use of our products for such purposes, please contact a Renesas sales office beforehand. Renesas shall have no liability for damages arising out of the uses set forth above.
8. Notwithstanding the preceding paragraph, you should not use Renesas products for the purposes listed below:
  - (1) artificial life support devices or systems
  - (2) surgical implantations
  - (3) healthcare intervention (e.g., excision, administration of medication, etc.)
  - (4) any other purposes that pose a direct threat to human lifeRenesas shall have no liability for damages arising out of the uses set forth in the above and purchasers who elect to use Renesas products in any of the foregoing applications shall indemnify and hold harmless Renesas Technology Corp., its affiliated companies and their officers, directors, and employees against any and all damages arising out of such applications.
9. You should use the products described herein within the range specified by Renesas, especially with respect to the maximum rating, operating supply voltage range, movement power voltage range, heat radiation characteristics, installation and other product characteristics. Renesas shall have no liability for malfunctions or damages arising out of the use of Renesas products beyond such specified ranges.
10. Although Renesas endeavors to improve the quality and reliability of its products, IC products have specific characteristics such as the occurrence of failure at a certain rate and malfunctions under certain use conditions. Please be sure to implement safety measures to guard against the possibility of physical injury, and injury or damage caused by fire in the event of the failure of a Renesas product, such as safety design for hardware and software including but not limited to redundancy, fire control and malfunction prevention, appropriate treatment for aging degradation or any other applicable measures. Among others, since the evaluation of microcomputer software alone is very difficult, please evaluate the safety of the final products or system manufactured by you.
11. In case Renesas products listed in this document are detached from the products to which the Renesas products are attached or affixed, the risk of accident such as swallowing by infants and small children is very high. You should implement safety measures so that Renesas products may not be easily detached from your products. Renesas shall have no liability for damages arising out of such detachment.
12. This document may not be reproduced or duplicated, in any form, in whole or in part, without prior written approval from Renesas.
13. Please contact a Renesas sales office if you have any questions regarding the information contained in this document, Renesas semiconductor products, or if you have any other inquiries.



**RENESAS SALES OFFICES**

<http://www.renesas.com>

Refer to "<http://www.renesas.com/en/network>" for the latest and detailed information.

**Renesas Technology America, Inc.**

450 Holger Way, San Jose, CA 95134-1368, U.S.A  
Tel: <1> (408) 382-7500, Fax: <1> (408) 382-7501

**Renesas Technology Europe Limited**

Dukes Meadow, Millboard Road, Bourne End, Buckinghamshire, SL8 5FH, U.K.  
Tel: <44> (1628) 585-100, Fax: <44> (1628) 585-900

**Renesas Technology (Shanghai) Co., Ltd.**

Unit 204, 205, AZIACenter, No.1233 Lujiazui Ring Rd, Pudong District, Shanghai, China 200120  
Tel: <86> (21) 5877-1818, Fax: <86> (21) 6887-7898

**Renesas Technology Hong Kong Ltd.**

7th Floor, North Tower, World Finance Centre, Harbour City, 1 Canton Road, Tsimshatsui, Kowloon, Hong Kong  
Tel: <852> 2265-6688, Fax: <852> 2730-6071

**Renesas Technology Taiwan Co., Ltd.**

10th Floor, No.99, Fushing North Road, Taipei, Taiwan  
Tel: <886> (2) 2715-2888, Fax: <886> (2) 2713-2999

**Renesas Technology Singapore Pte. Ltd.**

1 Harbour Front Avenue, #06-10, Keppel Bay Tower, Singapore 098632  
Tel: <65> 6213-0200, Fax: <65> 6278-8001

**Renesas Technology Korea Co., Ltd.**

Kukje Center Bldg. 18th Fl., 191, 2-ka, Hangang-ro, Yongsan-ku, Seoul 140-702, Korea  
Tel: <82> (2) 796-3115, Fax: <82> (2) 796-2145

**Renesas Technology Malaysia Sdn. Bhd**

Unit 906, Block B, Menara Amcorp, Amcorp Trade Centre, No.18, Jalan Persiaran Barat, 46050 Petaling Jaya, Selangor Darul Ehsan, Malaysia  
Tel: <603> 7955-9390, Fax: <603> 7955-9510