



UL E193009
TUV R2054535
CB JPTUV-001393
CE MARK

- 20 WATTS OUTPUT POWER
- 2:1 AND 4:1 WIDE INPUT VOLTAGE RANGE
- INTERNATIONAL SAFETY STANDARD APPROVAL
- SIX-SIDED CONTINUOUS SHIELD
- HIGH EFFICIENCY UP TO 86%
- STANDARD 2" X 1.6" X 0.4" PACKAGE
- FIXED SWITCHING FREQUENCY

The FDC20 and FDC20-W series offer 20 Watts of output power from a 2 x 1.6 x 0.4 inch package. The FDC20 series with 2:1 wide input voltage of 9-18, 18-36 and 36-75VDC. The FDC20-W series with 4:1 wide input voltage of 9-36 and 18-75VDC. The FDC20 and FDC20-W features 1600VDC of isolation, short-circuit and over-voltage protection, as well as six sided shielding. A safety approval to EN60950 and UL1950. All models are particularly suited to telecommunications, industrial, mobile telecom and test equipment applications.

TECHNICAL SPECIFICATION

All specifications are typical at nominal input, full load and 25°C otherwise noted

OUTPUT SPECIFICATIONS			
Output power	20 Watts max		
Voltage accuracy	Full load and nominal Vin	Single & Dual	± 2%
		Triple 3.3V/5V	± 2%
		Auxiliary	± 5%
Voltage adjustability	± 10%		
Minimum load (Note 1)	10% of FL		
Line regulation	LL to HL at Full Load	Single (W)	± 0.2%
		Dual (W)	± 0.5%
		Triple 3.3V/5V	± 1%
		Auxiliary	± 5%
Load regulation	25% to 100% FL	Single	± 0.5%
		Dual	± 3%
		Triple 3.3V/5V	± 2%
		Auxiliary	± 5%
Cross regulation (Note 2)		Dual	± 5%
		Triple 3.3V/5V	± 2%
		Auxiliary	± 5%
Ripple and noise	20MHz bandwidth	Single	75mVp-p
		Dual	100mVp-p
		Triple 3.3V/5V	50mVp-p
		Auxiliary	1% of Vout
Temperature coefficient	±0.02% / °C, max		
Transient response recovery time	25% load step change	500uS	
Over voltage protection	3.3V output	3.9V	
	5V output	6.2V	
	Zener diode clamp	12V output	15V
		15V output	18V
Short circuit protection	Hiccup, automatics recovery		
INPUT SPECIFICATIONS			
Input voltage range	FDC20	12V nominal input	9 – 18VDC
		24V nominal input	18 – 36VDC
	FDC20-W	48V nominal input	36 – 75VDC
		24V nominal input	9 – 36VDC
	48V nominal input	18 – 75VDC	
Input filter	Pi type		
Input surge voltage	12V input	36VDC	
	24V input	50VDC	
	48V input	100VDC	
Input reflected ripple (Note 3)	Nominal Vin and full load	25mA-p-p	
Start up time	Nominal Vin and constant resistor load	20mS typ	
Remote ON/OFF (Note 4)	DC-DC ON	Open or 3.5V < Vr < 12V	
	DC-DC OFF	Short or 0V < Vr < 1.2V	
Remote off input current	Nominal input	20mA	

GENERAL SPECIFICATIONS	
Efficiency	See table
Isolation voltage	1600VDC, min
Isolation resistance	10 ⁹ ohms, min
Isolation capacitance	300pF, max
Switching frequency	300KHz, typ
Approvals and standard	IEC60950, UL1950, EN60950
Case material	Nickel-coated copper
Base material	Non-conductive black plastic
Potting material	Epoxy (UL94-V0)
Dimensions	2.00 X 1.60 X 0.40 Inch (50.8 X 40.6 X 10.2 mm)
Weight	48g (1.69oz)
MTBF (Note 5)	1.928 x 10 ⁶ hrs
ENVIRONMENTAL SPECIFICATIONS	
Operating temperature range	-40°C ~ +85°C (with derating)
Maximum case temperature	+100°C
Storage temperature range	-55°C ~ +105°C
Thermal impedance (Note 6)	Nature convection 10°C/watt Nature convection with heat-sink 8.24°C/watt
Thermal shock	MIL-STD-810D
Vibration	10~55Hz, 2G, 30minutes along X,Y and Z
Relative humidity	5% to 95% RH
EMC CHARACTERISTICS	
Conducted emissions	EN55022 Level A
Radiated emissions	EN55022 Level A
ESD	EN61000-4-2 Perf. Criteria2
Radiated immunity	EN61000-4-3 Perf. Criteria2
Fast transient	EN61000-4-4 Perf. Criteria2
Surge	EN61000-4-5 Perf. Criteria2
Conducted immunity	EN61000-4-6 Perf. Criteria2



Model Number	Input Range	Output Voltage	Output Current	Input Current (7)	Eff (8) (%)	Capacitor (9) Load max
FDC20-12S33	9 – 18 VDC	3.3 VDC	4000mA	1507mA	77	13000uF
FDC20-12S05	9 – 18 VDC	5 VDC	4000mA	2193mA	80	6800uF
FDC20-12S12	9 – 18 VDC	12 VDC	1670mA	2136mA	82	2200uF
FDC20-12S15	9 – 18 VDC	15 VDC	1330mA	2136mA	82	755uF
FDC20-12D05	9 – 18 VDC	± 5 VDC	± 2000mA	2193mA	80	± 3400uF
FDC20-12D12	9 – 18 VDC	± 12 VDC	± 833mA	2136mA	82	± 680uF
FDC20-12D15	9 – 18 VDC	± 15 VDC	± 666mA	2136mA	82	± 450uF
FDC20-12T3312	9 – 18 VDC	3.3 / ± 12 VDC	3000 / ± 300mA	1926mA	78	4700 / ± 220uF
FDC20-12T3315	9 – 18 VDC	3.3 / ± 15 VDC	3000 / ± 250mA	1959mA	78	4700 / ± 220uF
FDC20-12T0512	9 – 18 VDC	5 / ± 12 VDC	2000 / ± 300mA	1885mA	80	4700 / ± 220uF
FDC20-12T0515	9 – 18 VDC	5 / ± 15 VDC	2000 / ± 250mA	1919mA	80	4700 / ± 220uF
FDC20-24S33 (W)	18 – 36 (9 – 36) VDC	3.3 VDC	4000mA	743 (764mA)	78 (76)	13000uF
FDC20-24S05 (W)	18 – 36 (9 – 36) VDC	5 VDC	4000mA	1082 (1111mA)	81 (79)	6800uF
FDC20-24S12 (W)	18 – 36 (9 – 36) VDC	12 VDC	1670mA	1054 (1082mA)	83 (81)	2200uF
FDC20-24S15 (W)	18 – 36 (9 – 36) VDC	15 VDC	1330mA	1054 (1082mA)	83 (81)	755uF
FDC20-24D05 (W)	18 – 36 (9 – 36) VDC	± 5 VDC	± 2000mA	1082 (1111mA)	81 (79)	± 3400uF
FDC20-24D12 (W)	18 – 36 (9 – 36) VDC	± 12 VDC	± 833mA	1054 (1082mA)	83 (81)	± 680uF
FDC20-24D15 (W)	18 – 36 (9 – 36) VDC	± 15 VDC	± 666mA	1041 (1068mA)	84 (82)	± 450uF
FDC20-24T3312	18 – 36 VDC	3.3 / ± 12 VDC	3000 / ± 300mA	950mA	79	4700 / ± 220uF
FDC20-24T3315	18 – 36 VDC	3.3 / ± 15 VDC	3000 / ± 250mA	967mA	79	4700 / ± 220uF
FDC20-24T0512	18 – 36 VDC	5 / ± 12 VDC	2000 / ± 300mA	931mA	81	4700 / ± 220uF
FDC20-24T0515	18 – 36 VDC	5 / ± 15 VDC	2000 / ± 250mA	947mA	81	4700 / ± 220uF
FDC20-48S33 (W)	36 – 75 (18 – 75) VDC	3.3 VDC	4000mA	367 (377mA)	79 (77)	13000uF
FDC20-48S05 (W)	36 – 75 (18 – 75) VDC	5 VDC	4000mA	543 (548mA)	82 (80)	6800uF
FDC20-48S12 (W)	36 – 75 (18 – 75) VDC	12 VDC	1670mA	527 (541mA)	83 (81)	2200uF
FDC20-48S15 (W)	36 – 75 (18 – 75) VDC	15 VDC	1330mA	527 (541mA)	83 (81)	755uF
FDC20-48D05 (W)	36 – 75 (18 – 75) VDC	± 5 VDC	± 2000mA	541 (556mA)	81 (79)	± 3400uF
FDC20-48D12 (W)	36 – 75 (18 – 75) VDC	± 12 VDC	± 833mA	514 (527mA)	85 (83)	± 680uF
FDC20-48D15 (W)	36 – 75 (18 – 75) VDC	± 15 VDC	± 666mA	508 (521mA)	86 (84)	± 450uF
FDC20-48T3312	36 – 75 VDC	3.3 / ± 12 VDC	3000 / ± 300mA	468mA	80	4700 / ± 220uF
FDC20-48T3315	36 – 75 VDC	3.3 / ± 15 VDC	3000 / ± 250mA	477mA	80	4700 / ± 220uF
FDC20-48T0512	36 – 75 VDC	5 / ± 12 VDC	2000 / ± 300mA	459mA	82	4700 / ± 220uF
FDC20-48T0515	36 – 75 VDC	5 / ± 15 VDC	2000 / ± 250mA	467mA	82	4700 / ± 220uF

(10) FDC20-24D3305

FDC20-48D3305, Output 3.3V(3A)/5V(2A), Detail Spec. Contact Factory.

Note

- The FDC20 series required a minimum 10% loading on the output to maintain specified regulation. Operation under no-load condition will not damage these devices, however they may not meet all listed specification.
- Cross regulation:
Dual output—Asymmetrical load 25% to 100% full load
Triple output – 3.3V / 5V 100% load and one of auxiliary 100% load, other auxiliary load change from 25% to 100% load
- Simulated source impedance of 12uH. 12uH inductor in series with +Vin.
- The ON/OFF control pin voltage is referenced to negative input
- BELLCORE TR-NWT-000332. Case 1: 50% Stress, Temperature at 40°C. (Ground fixed and controlled environment)
- Heat sink is optional and P/N: 7G-0011A.
Operation temperature range please see curve.
- Maximum value at nominal input voltage and full load.
- Typical value at nominal input voltage and full load.
- Test by minimum Vin and constant resistor load.
- The FDC20-24D3305 and FDC20-48D3305 are safety approval pending.

FDC20-48S05 Derating Curve

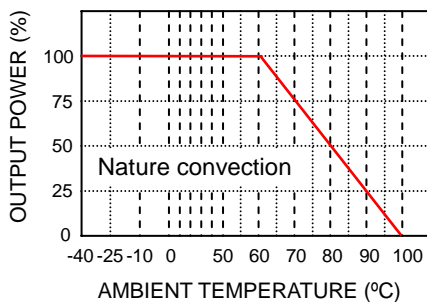

FDC20-48S05 Derating Curve With HEAT-SINK (Note 6)

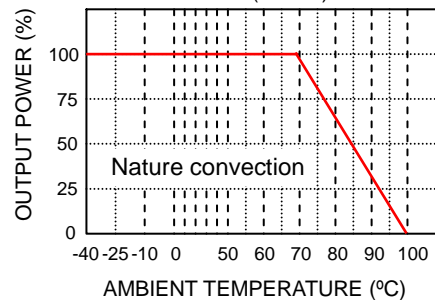

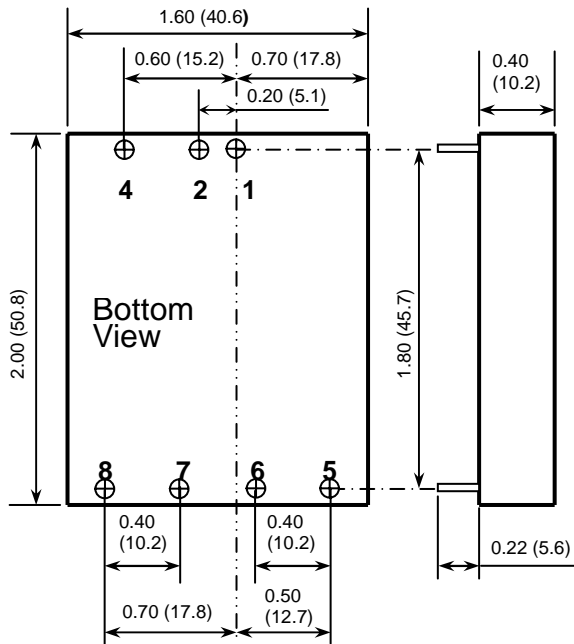
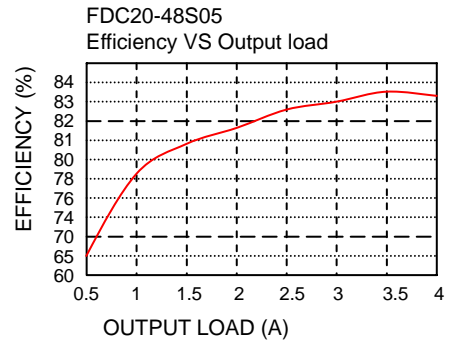
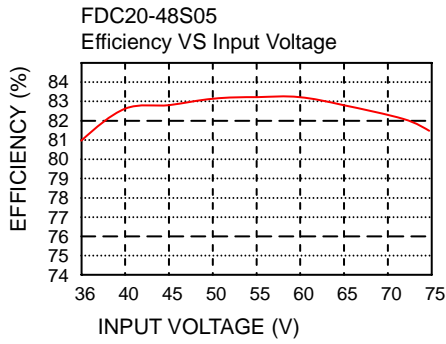

1. All dimensions in Inches (mm)
2. Pin pitch tolerance $\pm 0.014(0.35)$

PIN CONNECTION			
PIN	SINGLE	DUAL	TRIPLE
1	+ INPUT	+ INPUT	+ INPUT
2	- INPUT	- INPUT	- INPUT
4	CTRL	CTRL	CTRL
5	NO PIN	+ OUTPUT	+ AUXILIARY
6	+ OUTPUT	COMMON	+3.3V / +5V
7	- OUTPUT	- OUTPUT	COMMON
8	TRIM	TRIM	- AUXILIARY

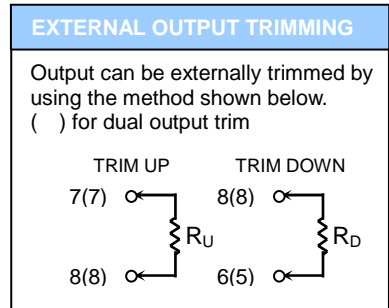

This datasheet has been downloaded from:

www.DatasheetCatalog.com

Datasheets for electronic components.