



SEMIPACK® 1

Rectifier Diode Modules

SKKD 81/16 G6

Features

- Heat transfer through aluminium oxide ceramic isolated metal baseplate
- UL recognized, file no. E63532

Typical Applications

- Non-controllable rectifiers for AC/AC converters
- Line rectifiers for transistorized AC motor controllers
- Field supply for DC motors

Absolute Maximum Ratings				
Symbol	Conditions		Values	Unit
Rectifier Diode				
I_{FAV}	sin. 180°	$T_c = 85\text{ °C}$	100	A
		$T_c = 100\text{ °C}$	75	A
I_{FSM}	10 ms	$T_j = 25\text{ °C}$	2000	A
		$T_j = 130\text{ °C}$	1750	A
i^2t	10 ms	$T_j = 25\text{ °C}$	20000	A ² s
		$T_j = 130\text{ °C}$	15313	A ² s
V_{RSM}			1700	V
V_{RRM}			1600	V
T_j			-40 ... 130	°C
Module				
T_{stg}			-40 ... 125	°C
V_{isol}	a.c.; 50 Hz; r.m.s.	1 min	3000	V
		1 s	3600	V

Characteristics						
Symbol	Conditions		min.	typ.	max.	Unit
Diode						
V_F	$T_j = 25\text{ °C}, I_F = 300\text{ A}$			1.50	1.65	V
$V_{(TO)}$	$T_j = 130\text{ °C}$			0.85	0.94	V
r_T	$T_j = 130\text{ °C}$			2.75	3.00	mΩ
I_{RD}	$T_j = 130\text{ °C}, V_{RD} = V_{RRM}$				3	mA
$R_{th(j-c)}$	cont.	per chip			0.25	K/W
		per module			0.125	K/W
$R_{th(j-c)}$	sin. 180°	per chip			0.27	K/W
		per module			0.135	K/W
Module						
$R_{th(c-s)}$	chip			0.22		K/W
	module			0.11		K/W
M_s	to heatsink M5		4.25		5.75	Nm
M_t	to terminals M5		2.55		3.45	Nm
a					5 * 9,81	m/s ²
w				75		g

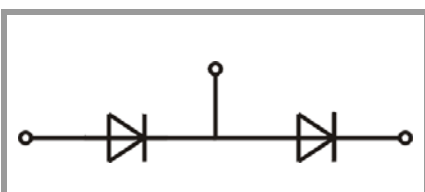

SKKD

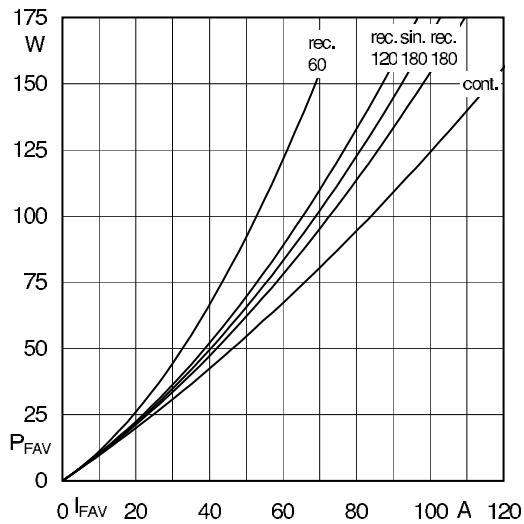

Fig. 11L: Power dissipation per diode vs. forward current

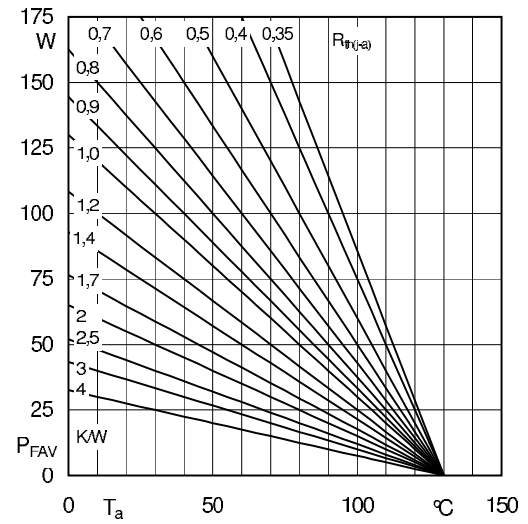

Fig. 11R: Power dissipation per diode vs. ambient temperature

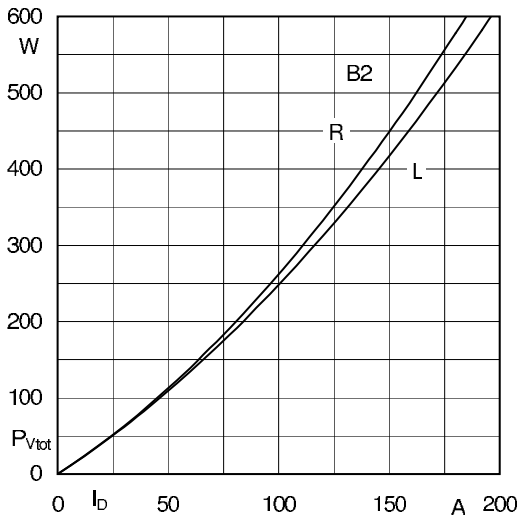

Fig. 12L: Power dissipation of two modules vs. direct current

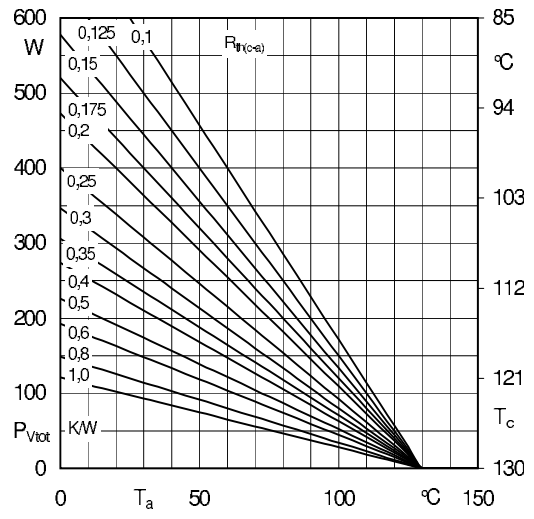

Fig. 12R: Power dissipation of two modules vs. case temperature

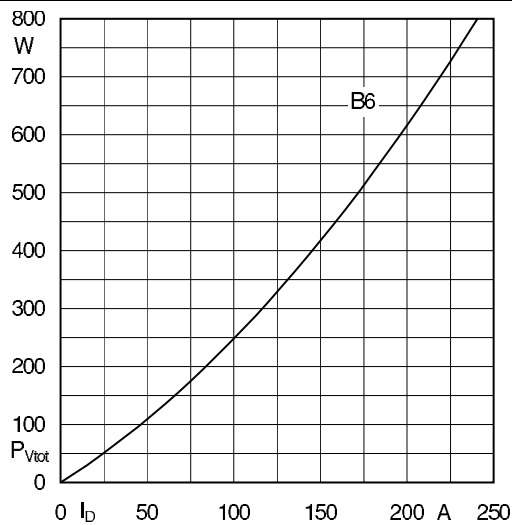

Fig. 13L: Power dissipation of three modules vs. direct current

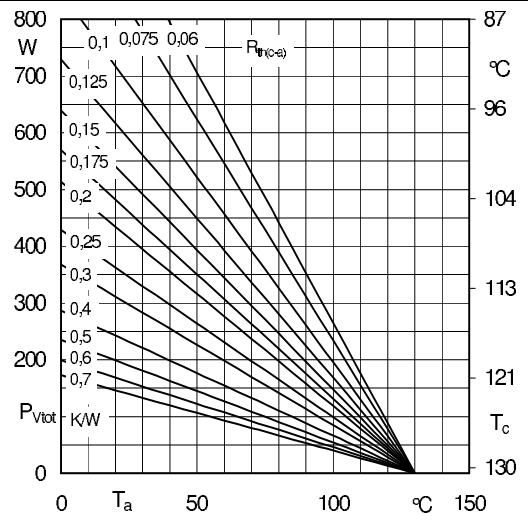

Fig. 13R: Power dissipation of three modules vs. case temperature

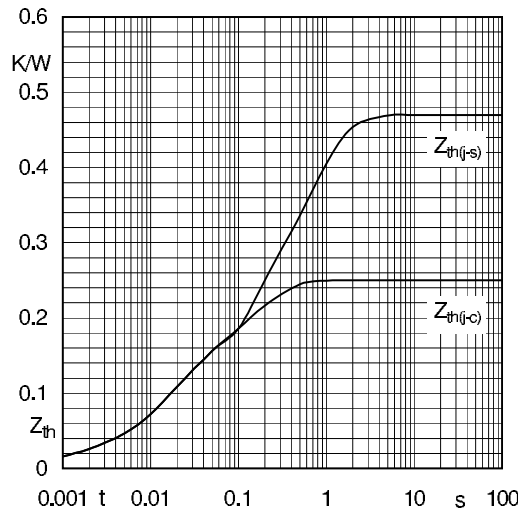

Fig. 14: Transient thermal impedance vs. time

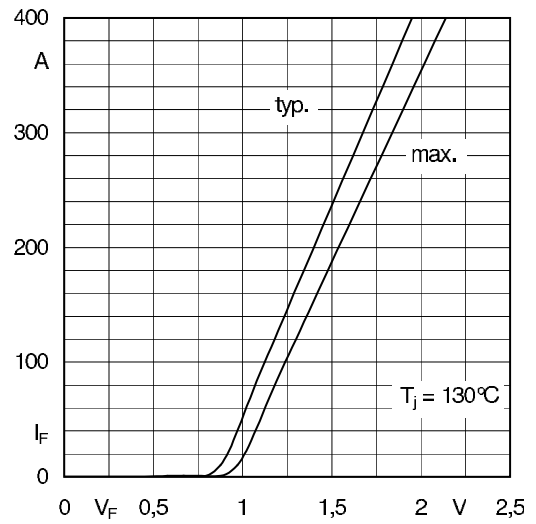

Fig. 15: Forward characteristics

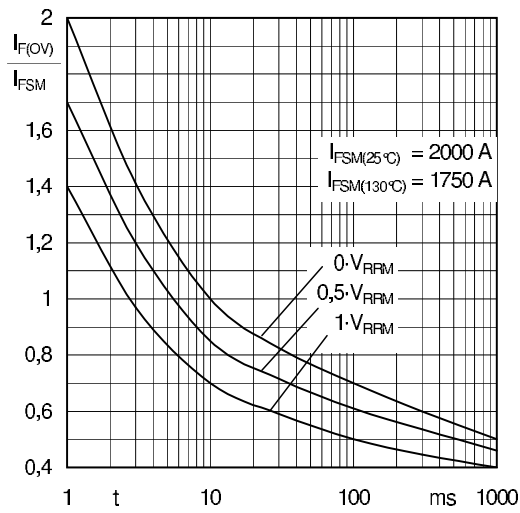
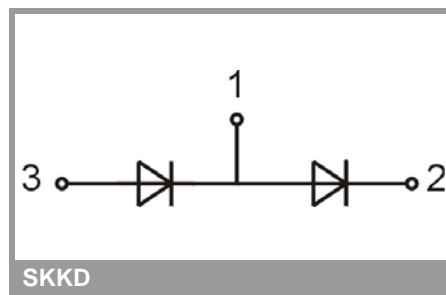
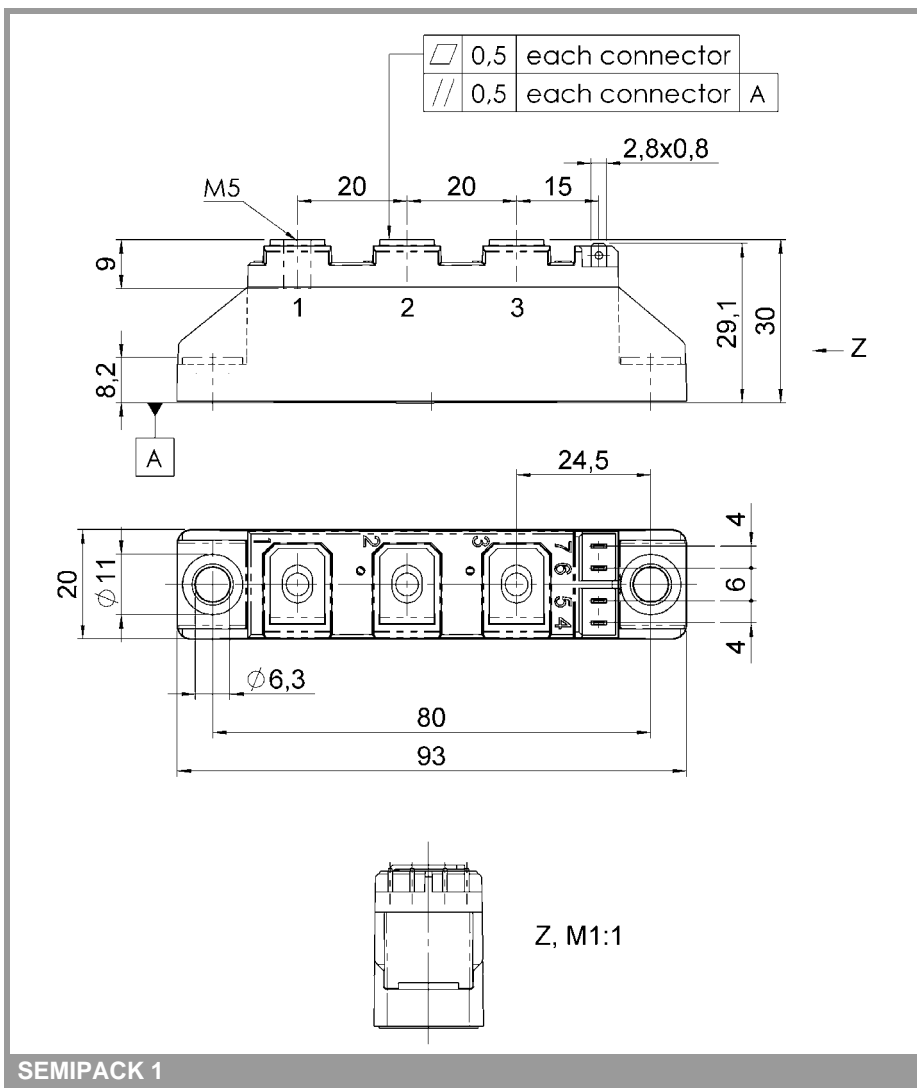

Fig. 16: Surge overload current vs. time

SKKD 81/16 G6



This technical information specifies semiconductor devices but promises no characteristics. No warranty or guarantee expressed or implied is made regarding delivery, performance or suitability.