

DRA818V
VHF Band Voice Transceiver Module

V1.23

Features:

- Frequency Range: 134~174MHz
- Tx/Rx frequency independent
- Channel space: 12.5/25KHz
- Configurable multi-channels
- Sensitivity: -122dBm
- Output power: +27/30dBm
- CTCSS / CDCSS codes
- 8 volume levels
- 8 squelch levels
- UART interface
- Temperature: -20°C ~+70°C
- TX current: 450/750mA
- Supply voltage: 3.3~4.5V



Applications

- Portable walkie-talkie
- Outdoor sports products
- Audio monitor system
- Building security system

DESCRIPTION

DRA818V is a type of compact wireless voice transceiver module based on RFIC RDA1846 and works in VHF band. It integrates high speed microcontroller, high performance wireless transceiver IC, high power PA, audio process and squelching circuits. It provides standard UART interface which users can easily configure appropriate parameters for different applications. Users can easily construct a walkie-talkie system by connecting microphone, audio PA and speaker.

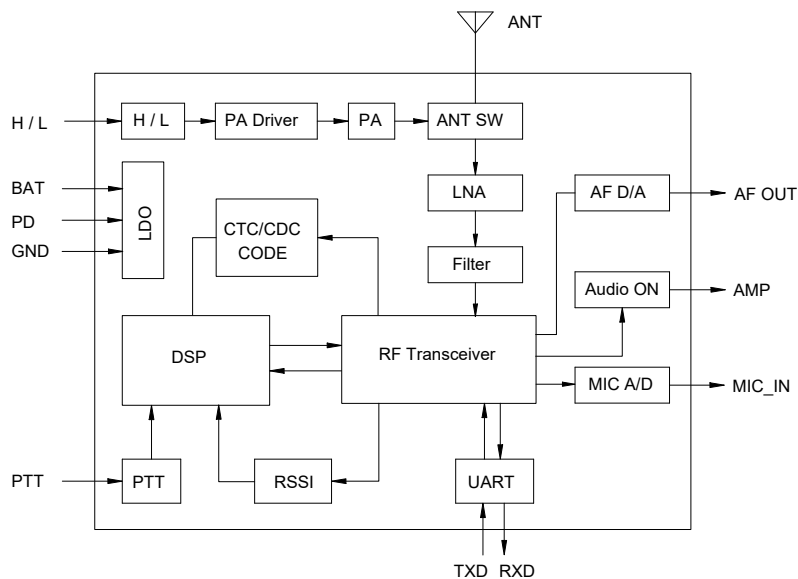

Figure 1: DRA818V Functional Block

PIN FUNCTIONS

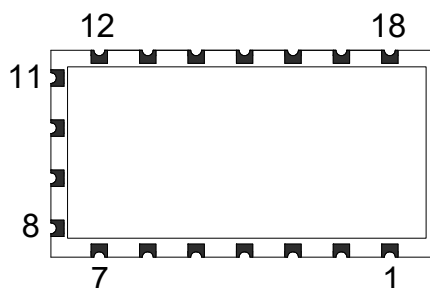

Figure 2: DRA818V Pin Layout

PIN	Name	Function	Description
1	SQ	Output	Squelch detection.. Low→ Audio amplifier on
2	NC	---	No connection
3	AF_OUT	Output	Audio output pin.
4	NC	---	No connection
5	PTT	Input	Tx/Rx control pin: Low→TX; High→ RX
6	PD	Input	Power saving control pin: Low→sleep mode; High→normal mode
7	H/L	Input	RF Power Selection: Low→0.5W; float ed→1W
8	VBAT	Power	Power supply
9	GND	Ground	Ground (0V)
10	GND	Ground	Ground (0V)
11	NC	---	No connection
12	ANT	---	Antenna port. 50 Ohm impedance
13	NC	---	No connection
14	NC	---	No connection
15	NC	---	No connection
16	RXD	Input	UART input, TTL level
17	TXD	Output	UART output, TTL level
18	MIC_IN	Input	MIC input

Table 1: DRA818V Pin Functions

ELECTRICAL SPECIFICATIONS

Symbol	Parameter (condition)	Min.	Typ.	Max.	Units
VCC	Supply Voltage	3.3	4.0	4.5	V
Freq	Frequency range	134		174	MHz
Temp	Operating temperature range	-20	25	70	°C
IDD_R	Current in receive mode @ Audio amplifier on		60		mA

	@ Audio amplifier off		55		mA
IDD_T ^(a)	Current in transmit mode	@ Low Power Mode	400	550	mA
		@ High Power Mode	700	750	
IDD_S	Current in sleep mode		1		uA
CH_w	Channel Space selection		25		KHz
T_sw	Tx/Rx switching time		20		mS
T_IN	Module initializing time		300	500	mS
ZANT	Antenna Impedance		50		Ohm

Table 2: DRA818V Electrical Specifications

RADIO CHARACTERISTICS

Symbol	Parameter (condition)	Min.	Typ.	Max.	Units
Freq	Frequency range	134		174	MHz
Sen.	Receiver sensitivity @12dB SINAD		-122		dBm
Sen_sq	Squelch function sensitivity		-120		dBm
SNR_R	S/N in receive mode @ 1.5KHz Fdev.	45	50		dB
ACS	Adjacent channel selection @ CH_w = 25 KHz	55	60		dB
IR	Inter-modulation rejection @ CH_w = 25 KHz	55	60		dB
SPR	Spurious emission rejection@ CH_w = 25 KHz	55	60		dB
AF_ZOUT	Audio output impedance		200		Ohm
AF_AMP	Audio signal amplitude @1KHz		700		mV
Pout	Output power	@ Low Power Mode	26	27	dBm
		@ High Power Mode	29	31	
Fdev	Max. Frequency deviation @ Narrow band			2.5	KHz
Sen_MOD	Modulation Sensitivity @1KHz at 2.5KHz Fdev.		10		mV
AF_TD	Audio modulation distortion@1KHz at 2.5KHz Fdev.		2	5	%
SNR_T	S/N in Transmit mode @1KHz at 2.5KHz Fdev.	38	40	45	dB
Fdev_c	CTCSS frequency deviation	0.35	0.5	0.75	KHz

Table 3: DRA818V Radio Characteristics

ABSOLUTE MAXIMUM RATINGS

Symbol	Parameter	Min.	Max.	Units
VCC	Supply Voltage	-3.3	5	V
V _{IN}	Input voltage	-0.3	VCC+0.3	V
I _{IN}	Input current	-10	10	mA
T _{ST}	Storage temperature	-40	90	°C

Table 4: DRA818V Maximum Ratings**PARAMETERS SETTING**

Some parameters of DRA818V modules can be changed by following the commands in this section, which provide flexibility for designers to optimize related parameters to achieve the best performance. DRA818V modules use standard UART interface to communicate with microcontrollers or other hosts. The default data format is: 8 data bits, 1 stop bit, no parity and 9600 kbps data rate. All commands in ASCII codes start with “AT” and end with “<CR><LF>”. The parameters will be lost after the module is powered off. Therefore, the module must be configured with the parameters at each power-on in order to work normally.

1. Handshake Command

Description: It is used to check if the module works normally. DRA818V module will send back response information when it receives this command from the host. If the host doesn't receive any response from module after three times of continuously sending this command, it will restart the module.

Format: `AT+DMOCONNECT <CR><LF>`

Module response: `+DMOCONNECT: 0 <CR><LF>`

2. Frequency Scanning Command

Description: It scans the wanted frequency.

Format: `S+Frequency <CR><LF>`

Module response: `S=x <CR><LF>`

`x → 0`: there is signal in this frequency

`x → 1`: there is no signal in this frequency

E.g Command: `S+152.1250`

Response: `S=0`

3. Group Setting Command

Description: This command is used to configure a group of module parameters.

Format: `AT+DMOSETGROUP=GBW,TFV,RFV,Tx_CTCSS,SQ,Rx_CTCSS<CR><LF>`

Module response: `+DMOCONNECT: x<CR><LF>`

- **GBW:** Channels space. 1 → 25k. The RFIC RDA1846S offers the channel space selection for 12.5KHz and 25KHz. The firmware only chooses 25KHz option fixedly. However the frequency modulation deviation in 25KHz channel space is still very narrow (about +/-2.5KHz) so the module works more likely at 12.5KHz channel space.
- **TFV:** Transmit frequency. Range: 134.0000~174.0000MHz
- **RFV:** Receive frequency. Range: 134.0000~174.0000MHz.
- **Tx_CTCSS:** CTCSS value in transmit
- **SQ:** Squelch level (0~8). 0 → monitor mode which can't be used in scanning mode.
- **Rx_CTCSS:** CTCSS value in receive
- **x:** Configuration result. 0 → succeeded; 1 → data out of range.

E.g. Command: `AT+DMOSETGROUP=0,152.1250,152.1250,0012,4,0003<CR><LF>`

Or Command: `AT+DMOSETGROUP=0,152.1250,152.1250,754N,4,445I<CR><LF>`

Response: `+DMOSETGROUP:0<CR><LF>`

Notes: The Tx_CXCSS and Rx_CXCSS can be different values. 0000 → no coding; 0001~0038 → CTCSS; Alphanum → CDCSS (seeing table 6).

3. Volume Command

Description: This command is used to adjust the volume of module.

Format: `AT+DMOSETVOLUME=x <CR><LF>`

Module response: `+DMOSETVOLUME: X<CR><LF>`

- x in command: Volume range (1~8).
- x in response: 0 → succeeded; 1 → failed.

4. SETFILTER Command

Description: This command is used to turn on/off Pre/de-emphasis, Highpass, Lowpass filter

Format: `AT+SETFILTER=PRE/DE-EMPH,Highpass,Lowpass <CR><LF>`

Module response: `+DMOSETFILTER: x<CR><LF>`

- PRE/DE-EMPH=0 → turn on; 1 → turn off
- Highpass=0 → turn on; 1 → turn off
- Lowpass=0 → turn on; 1 → turn off

E.g. `AT+SETFILTER=0,0,0`

Response: `+DMOSETFILTER:0`

From the field testing results, the RFIC on module should automatically filter the frequencies

below 300Hz no mater Highpass filter is enabled or not so please pay attention to it if the applications need low frequency.

Code	Equivalent BIN	Equivalent HEX
023I	11001000000111000110111	640E37
025I	10101000000111101101011	540F6B
026I	01101000000110111010011	340DD3
031I	10011000000111111000101	4C0FC5
032I	01011000000110101111101	2C0D7D
043I	11000100000101101101101	620B6D
047I	11100100000110111111000	720DF8
051I	10010100000101010011111	4A0A9F
054I	00110100000100101111011	1A097B
065I	10101100000110001011101	560C5D
071I	10011100000110011110011	4E0CF3
072I	01011100000111001001011	2E0E4B
073I	11011100000101100111010	6E0B3A
074I	00111100000111100010111	1E0F17
114I	00110010000101111010110	190BD6
115I	10110010000111010100111	590EA7
116I	01110010000110000011111	390C1F
125I	10101010000111011110000	550EF0
131I	10011010000111001011110	4D0E5E
132I	01011010000110011100110	2D0CE6
134I	00111010000110110111010	1D0DBA
143I	11000110000101011110110	630AF6
152I	01010110000100110111100	2B09BC
155I	10110110000110110010001	5B0D91
156I	01110110000111100101001	3B0F29
162I	01001110000100111101011	2709EB
165I	10101110000110111000110	570DC6
172I	01011110000111111010000	2F0FD0
174I	00111110000111010001100	1F0E8C
205I	10100001000110010111011	508CBB
223I	11001001000101110001011	648B8B
226I	01101001000100001101111	34886F
243I	11000101000111011010001	628ED1
244I	00100101000101011111100	128AFC
245I	10100101000111110001101	528F8D

251I	10010101000111100100011	4A8F23
261I	10001101000111101110100	468F74
263I	11001101000100010111101	6688BD
265I	10101101000100111100001	5689E1
271I	10011101000100101001111	4E894F
306I	01100011000111110011000	318F98
311I	10010011000110110001110	498D8E
315I	10110011000101100011011	598B1B
331I	10011011000101111100010	4D8BE2
343I	11000111000111101001010	638F4A
346I	01100111000110010101110	338CAE
351I	10010111000111010111000	4B8EB8
364I	00101111000110100001011	178D0B
365I	10101111000100001111010	57887A
371I	10011111000100011010100	4F88D4
411I	10010000100101101110111	484B77
412I	01010000100100111001111	2849CF
413I	11010000100110010111110	684CBE
423I	11001000100110011101001	644CE9
431I	10011000100110100011011	4C4D1B
432I	01011000100111110100011	2C4FA3
445I	10100100100100011101111	5248EF
464I	00101100100101111110010	164BF2
465I	10101100100111010000011	564E83
466I	01101100100110000111011	364C3B
503I	11000010100101100011110	614B1E
506I	01100010100100011111010	3148FA
516I	01110010100111011000001	394EC1
532I	01011010100111000111000	2D4E38
546I	01100110100101111001100	334BCC
565I	10101110100111100011000	574F18
606I	01100001100110011011101	30CCDD
612I	01010001100110001110011	28CC73
624I	00101001100110101111000	14CD78
627I	11101001100111111000000	74CFC0
631I	10011001100100010100111	4CC8A7
632I	01011001100101000011111	2CCA1F
654I	00110101100111000011001	1ACE19
662I	01001101100111100010010	26CF12
664I	00101101100111001001110	16CE4E
703I	11000011100111010100010	61CEA2

712I	01010011100110111101000	29CDE8
723I	11001011100100011001110	65C8CE
731I	10011011100100100111100	4DC93C
732I	01011011100101110000100	2DCB84
734I	00111011100101011011000	1DCAD8
743I	11000111100110110010100	63CD94
754I	00110111100111110000010	1BCF82

Table 5: DRA818V CDCSS

Notes: The N codes is the Bitwise-NOT of I codes. E.g. 023N=¬023I= 00110111111000111001000

TYPICAL APPLICATION CIRCUIT

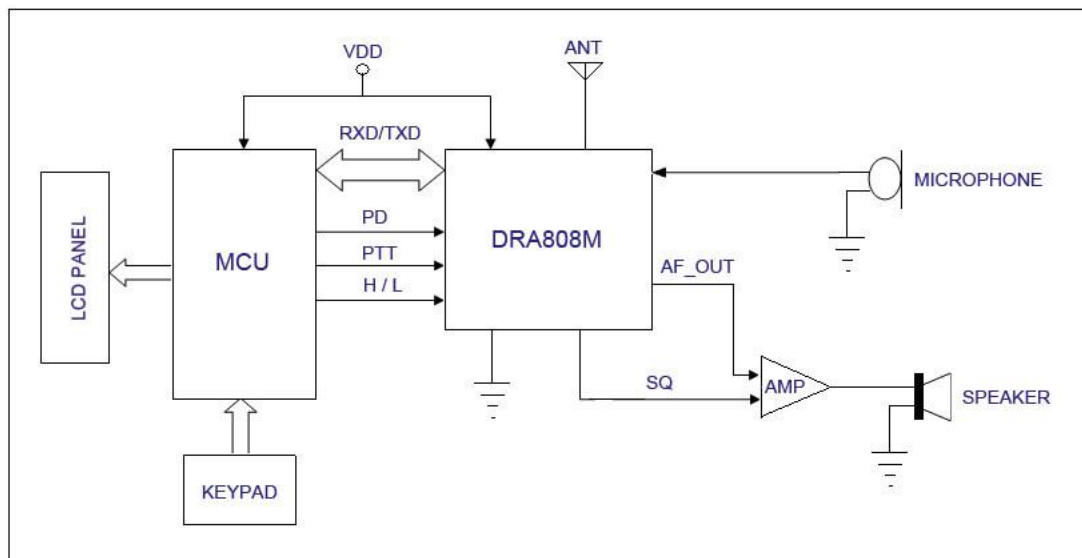

Figure 3: DRA818V Application Circuit

MECHANICAL DATA

Unit:mm

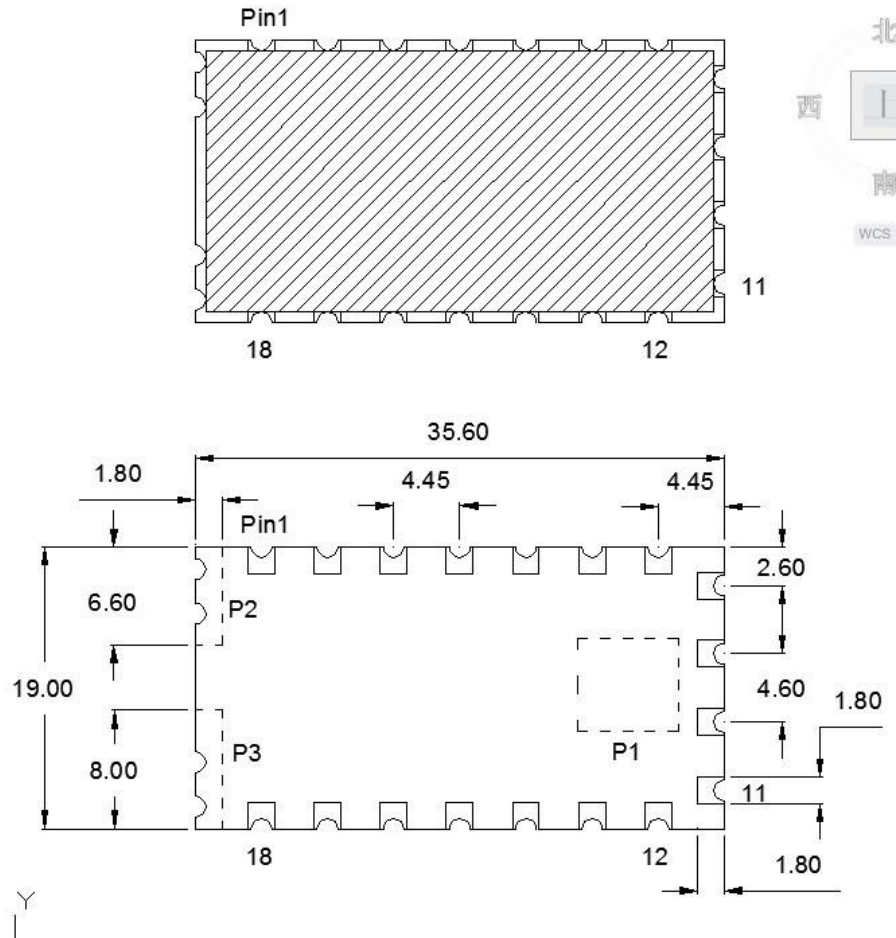

Figure 4: DRA818V Mechanical Dimension

ORDERING INFORMATION

DRA818V and DRA818U are based on RDA1846. Comparing to DRA808M based on RDA1845, CDCSS and audio control AT command are added, which provides more flexibility for the users who need to process audio signal more precisely. DRA818U is the UHF band version of DRA818V.

Part Name	Frequency Range	RFIC	Dimension
DRA808M	400~470MHz	RDA1845	Compatible
DRA818U	400~470MHz	RDA1846	Compatible
DRA818V	134~174MHz	RDA1846	Compatible

Table 6: Ordering Information

<p>Dorji Applied Technologies A division of <i>Dorji Industrial Group Co., Ltd</i></p> <p>Add.: Xinchenuayuan 2, Dalangnanlu, Longhua, Baoan district, Shenzhen, China 518109</p> <p>Tel: 0086-755-28156122 Fax.: 0086-755-28156133 Email: sales@dorji.com Web: http://www.dorji.com</p>	<p>Dorji Industrial Group Co., Ltd reserves the right to make corrections, modifications, improvements and other changes to its products and services at any time and to discontinue any product or service without notice. Customers are expected to visit websites for getting newest product information before placing orders.</p> <p>These products are not designed for use in life support appliances, devices or other products where malfunction of these products might result in personal injury. Customers using these products in such applications do so at their own risk and agree to fully indemnify Dorji Industrial Group for any damages resulting from improper use.</p>
---	---