

# KA7500B

## SMPS Controller

### Features

- Internal Regulator Provides a Stable 5V Reference Supply Trimmed to 5%
- Uncommitted Output TR for 200mA Sink or Source Current
- Output Control For Push-Pull or Single Ended Operation
- Variable Duty Cycle By Dead Time Control (Pin 4) Complete PWM Control Circuit
- On-Chip Oscillator With Master or Slave Operation
- Internal Circuit Prohibits Double Pulse at Either Output

### Description

The KA7500B is used for the control circuit of the PWM switching regulator. The KA7500B consists of 5V reference voltage circuit, two error amplifiers, a flip flop, an output control circuit, a PWM comparator, a dead time comparator and an oscillator. This device can be operated in the switching frequency of 1kHz to 300kHz.



### Internal Block Diagram

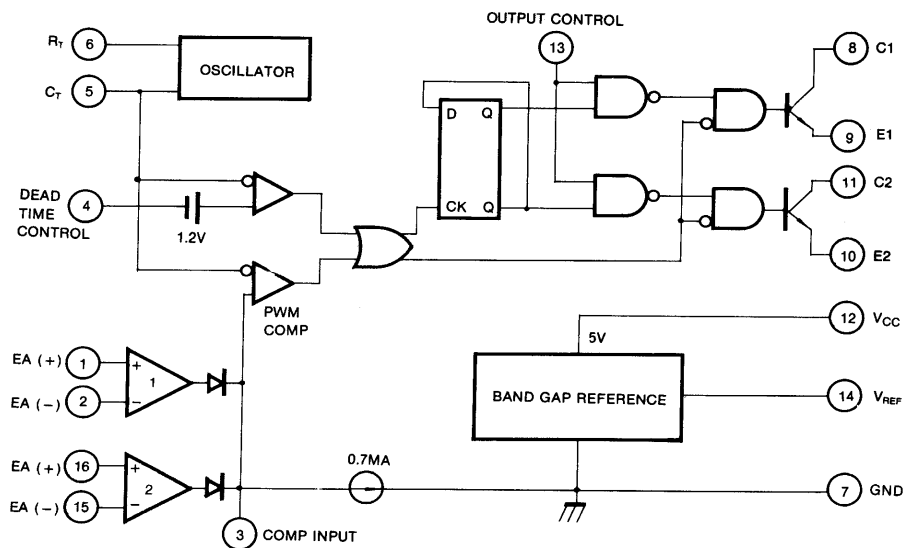

## Absolute Maximum Ratings

Parameter	Symbol	Value	Unit
Supply Voltage	V <sub>CC</sub>	42	V
Collector Supply Voltage	V <sub>C</sub>	42	V
Output Current	I <sub>O</sub>	250	mA
Amplifier Input Voltage	V <sub>IN</sub>	V <sub>CC</sub> +0.3	V
Power Dissipation (T <sub>A</sub> = 25°C)	P <sub>D</sub>	1 (KA7500B) 0.9 (KA7500BD)	W
Operating Temperature Range	T <sub>OPR</sub>	0 ~ +70	°C
Storage Temperature Range	T <sub>STG</sub>	-65 ~ +150	°C

## Electrical Characteristics

( $V_{CC} = 20V$ ,  $f = 10kHz$ ,  $T_A = 0^{\circ}C$  to  $+70^{\circ}C$ , unless otherwise specified)

Parameter	Symbol	Conditions	Min.	Typ.	Max.	Unit
<b>REFERENCE SECTION</b>						
Reference Output Voltage	$V_{REF}$	$I_{REF} = 1mA$	4.75	5.0	5.25	V
Line Regulation	$\Delta V_{REF}$	$V_{CC} = 7V$ to $40V$	-	2.0	25	mV
Temperature Coefficient of $V_{REF}$	$\Delta V_{REF}/\Delta T$	$T_A = 0^{\circ}C$ to $70^{\circ}C$	-	0.01	0.03	%/ $^{\circ}C$
Load Regulation	$\Delta V_{REF}$	$I_{REF} = 1mA$ to $10mA$	-	1.0	15	mV
Short-Circuit Output Current	$I_{SC}$	$V_{REF} = 0V$	10	35	50	mA
<b>OSCILLATOR SECTION</b>						
Oscillation Frequency	f	$C_T = 0.01\mu F$ , $R_T = 12k\Omega$	-	10	-	kHz
Frequency Change with Temperature	$\Delta f/\Delta T$	$C_T = 0.01\mu F$ , $R_T = 12k\Omega$	-	-	2	%
<b>DEAD TIME CONTROL SECTION</b>						
Input Bias Current	$I_{BIAS}$	$V_{CC} = 15V$ , $0V \leq V_4 \leq 5.25V$	-	-2.0	-10	$\mu A$
Maximum Duty Cycle	$D(MAX)$	$V_{CC} = 15V$ , $V_4 = 0V$ $O.C$ Pin = $V_{REF}$	45	-	-	%
Input Threshold Voltage	$V_{ITH}$	Zero Duty Cycle	-	3.0	3.3	V
		Max. Duty Cycle	0	-	-	
<b>ERROR AMP SECTION</b>						
Input Offset Voltage	$V_{IO}$	$V_3 = 2.5V$	-	2.0	10	mV
Input Offset Current	$I_{IO}$	$V_3 = 2.5V$	-	25	250	mA
Input Bias Current	$I_{BIAS}$	$V_3 = 2.5V$	-	0.2	1.0	$\mu A$
Common Mode Input Voltage	$V_{CM}$	$7V \leq V_{CC} \leq 40V$	-0.3	-	$V_{CC}$	V
Open-Loop Voltage Gain	$G_{VO}$	$0.5V \leq V_3 \leq 3.5V$	70	95	-	dB
Unit-Gain Bandwidth (Note1)	BW	-	-	650	-	kHz
<b>PWM COMPARATOR SECTION</b>						
Input Threshold Voltage	$V_{ITH}$	Zero Duty Cycle	-	4	4.5	V
Input Sink Current	$I_{SINK}$	$V_3 = 0.7V$	-0.3	-0.7	-	mV
<b>OUTPUT SECTION</b>						
Output Saturation Voltage Common Emitter	$V_{CE(SAT)}$	$V_E = 0$ , $I_C = 200mA$	-	1.1	1.3	V
Common Collector	$V_{CC(SAT)}$	$V_C = 15V$ , $I_E = -200mA$	-	1.5	2.5	
Collector Off-State Current	$I_C(OFF)$	$V_{CC} = 40V$ , $V_{CE} = 40V$	-	2	100	$\mu A$
Emitter Off-State Current	$I_E(OFF)$	$V_{CC} = V_C = 40V$ , $V_E = 0$	-	-	-100	
<b>TOTAL DEVICE</b>						
Supply Current	$I_{CC}$	Pin 6 = $V_{REF}$ , $V_{CC} = 15V$	-	6	10	mA
<b>OUTPUT SWITCHING CHARACTERISTICS</b>						
Rise Time	$t_R$	-	-	-	-	-
Common Emitter	-	-	-	100	200	ns
Common Collector	-	-	-	100	200	
Fall Time	$t_F$	-	-	-	-	-
Common Emitter	-	-	-	25	100	ns
Common Collector	-	-	-	40	100	

### Note:

1. This parameter, although guaranteed, is not 100% tested in production.

# Typical Application

## Pulse Width Modulated Step-down Converter

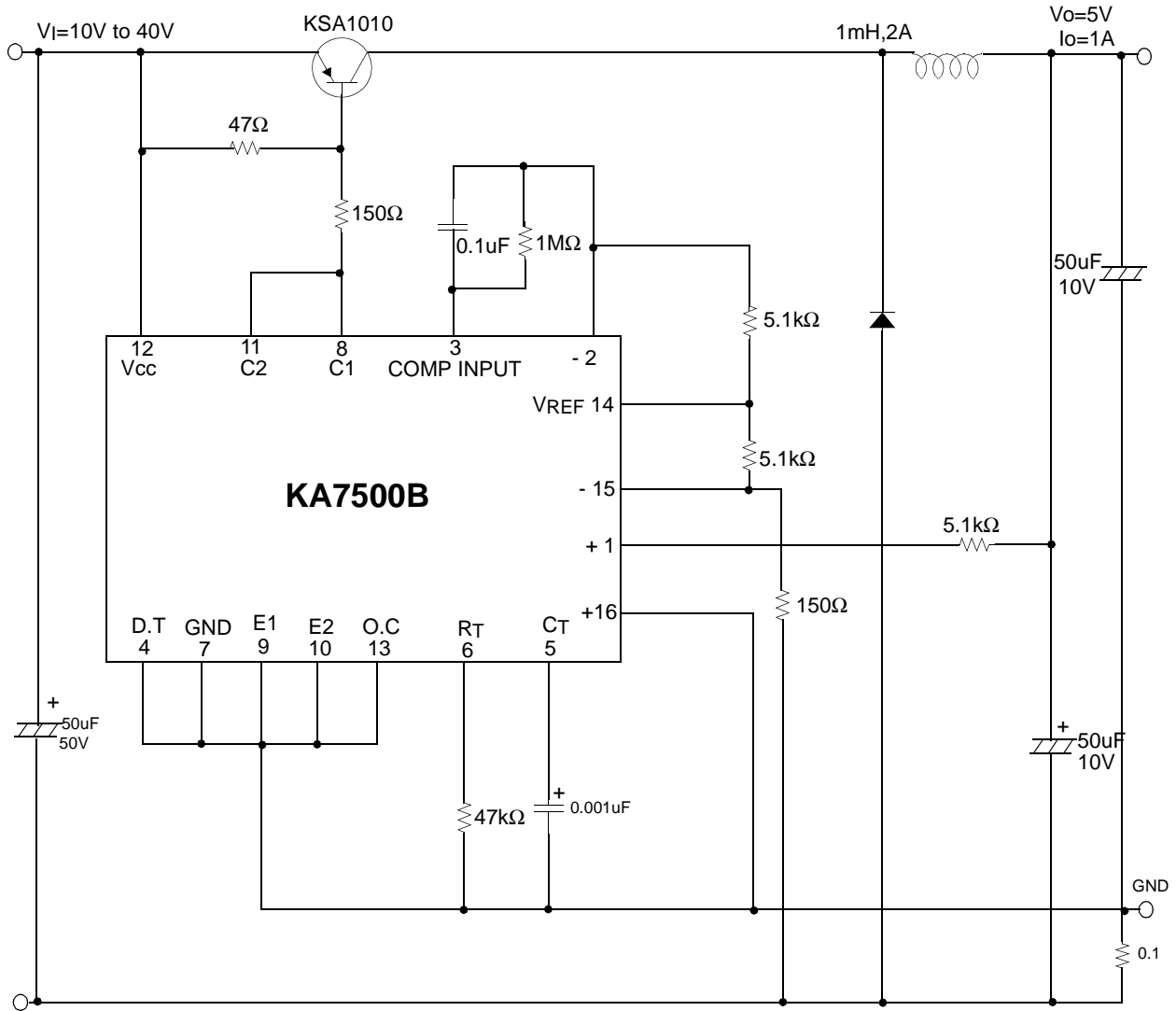

# Mechanical Dimensions

## Package

### 16-DIP

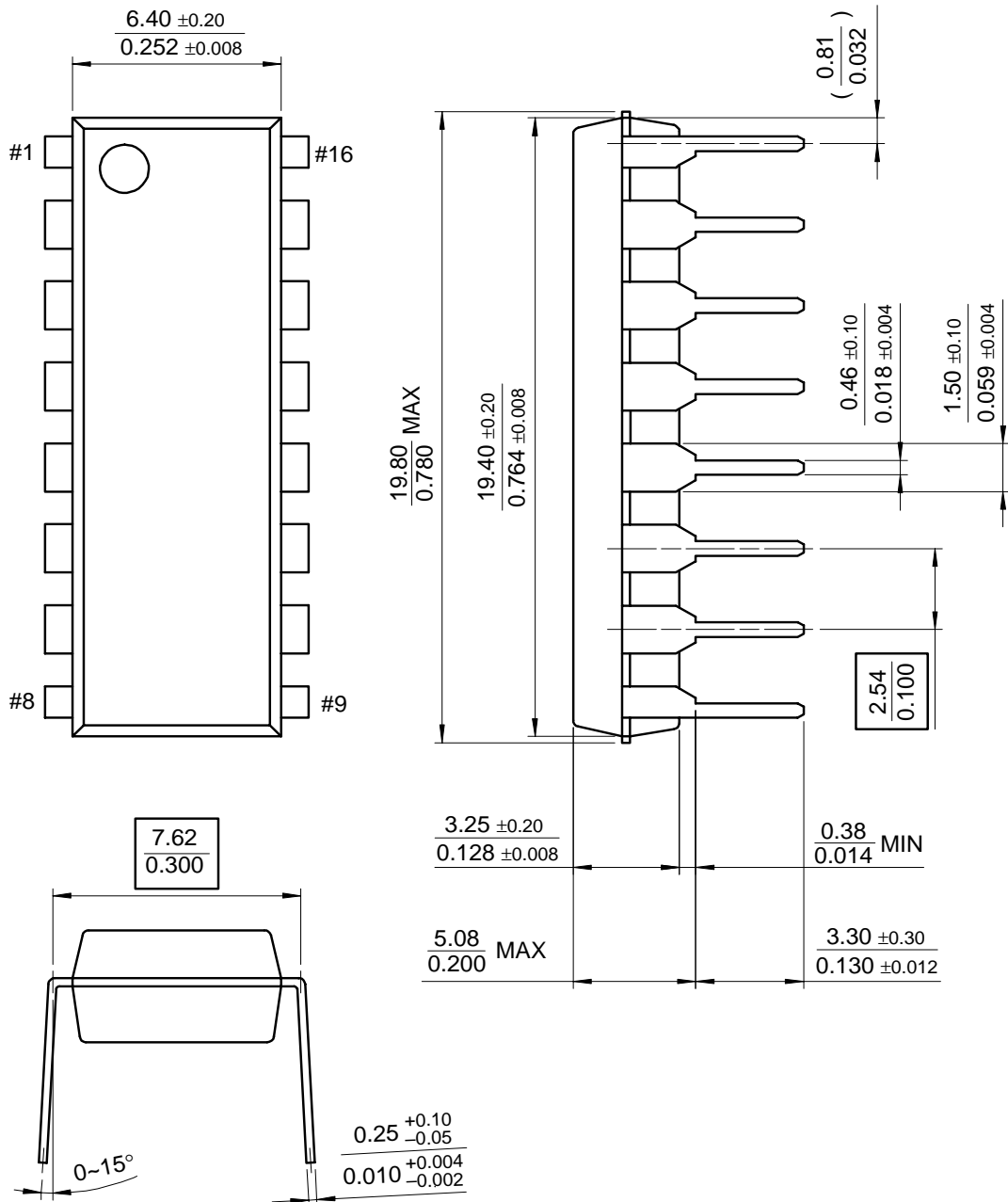

Mechanical Dimensions (Continued)

Package

16-SOP

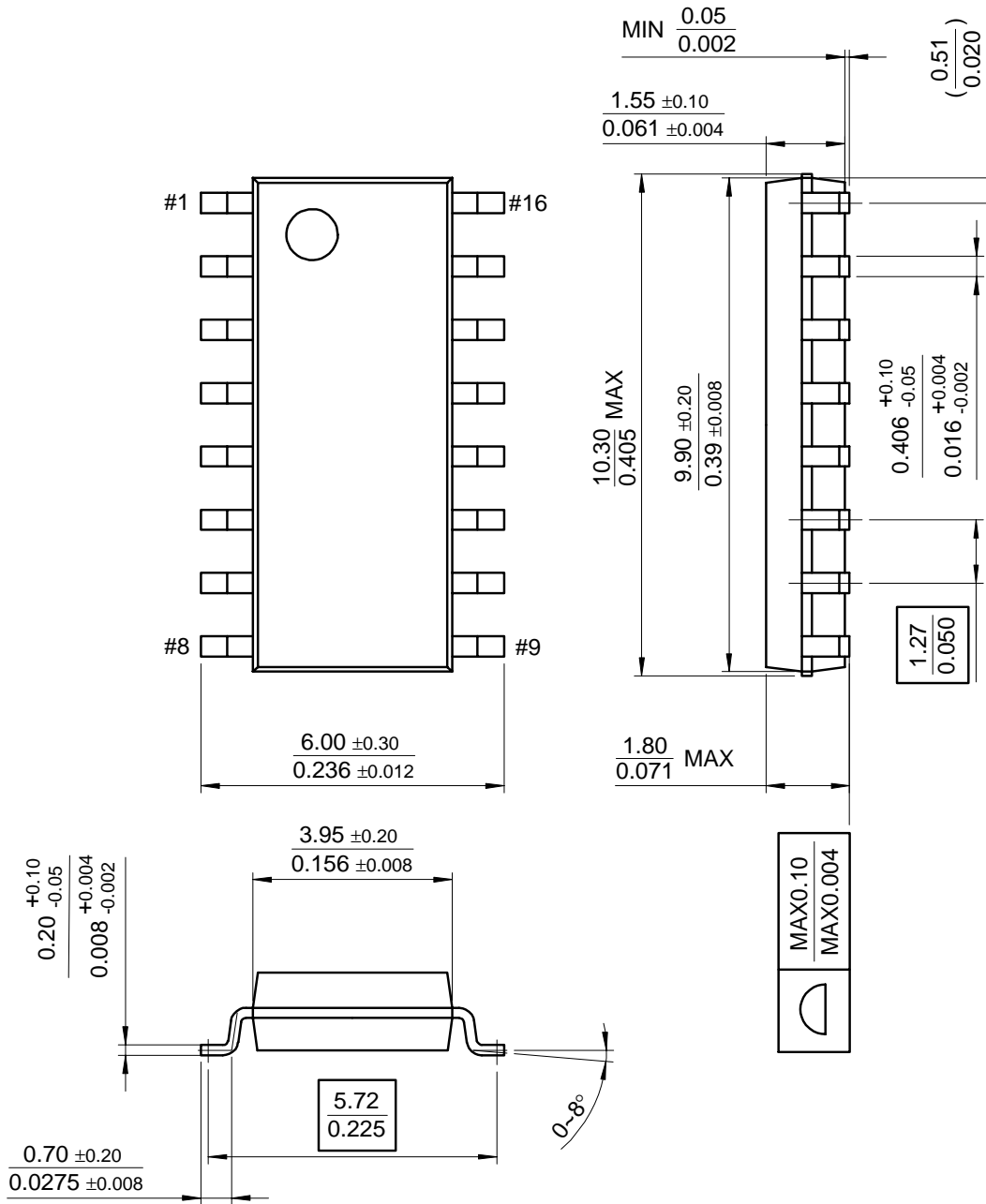

---

## Ordering Information

Product Number	Package	Operating Temperature
KA7500B	16-DIP	0 ~ +70°C
KA7500BD	16-SOP	

**DISCLAIMER**

FAIRCHILD SEMICONDUCTOR RESERVES THE RIGHT TO MAKE CHANGES WITHOUT FURTHER NOTICE TO ANY PRODUCTS HEREIN TO IMPROVE RELIABILITY, FUNCTION OR DESIGN. FAIRCHILD DOES NOT ASSUME ANY LIABILITY ARISING OUT OF THE APPLICATION OR USE OF ANY PRODUCT OR CIRCUIT DESCRIBED HEREIN; NEITHER DOES IT CONVEY ANY LICENSE UNDER ITS PATENT RIGHTS, NOR THE RIGHTS OF OTHERS.

**LIFE SUPPORT POLICY**

FAIRCHILD'S PRODUCTS ARE NOT AUTHORIZED FOR USE AS CRITICAL COMPONENTS IN LIFE SUPPORT DEVICES OR SYSTEMS WITHOUT THE EXPRESS WRITTEN APPROVAL OF THE PRESIDENT OF FAIRCHILD SEMICONDUCTOR CORPORATION. As used herein:

1. Life support devices or systems are devices or systems which, (a) are intended for surgical implant into the body, or (b) support or sustain life, and (c) whose failure to perform when properly used in accordance with instructions for use provided in the labeling, can be reasonably expected to result in a significant injury of the user.
2. A critical component in any component of a life support device or system whose failure to perform can be reasonably expected to cause the failure of the life support device or system, or to affect its safety or effectiveness.