

SOT-23 Encapsulate Adjustable Reference Source

Device Description

The TL431 is a three-terminal adjustable shunt regulator offering excellent temperature stability. This device has a typical dynamic output impedance of 0.2Ω . The device can be used as a replacement for zener diodes in many applications.

FEATURES

- The output voltage can be adjusted to 36V
- Low dynamic output impedance, its typical value is 0.2Ω
- Trapping current capability is 1 to 100mA
- Low output noise voltage
- Fast on -state response
- The effective temperature compensation in the working range of full temperature
- The typical value of the equivalent temperature factor in the whole temperature scope is $50 \text{ ppm}/^\circ\text{C}$

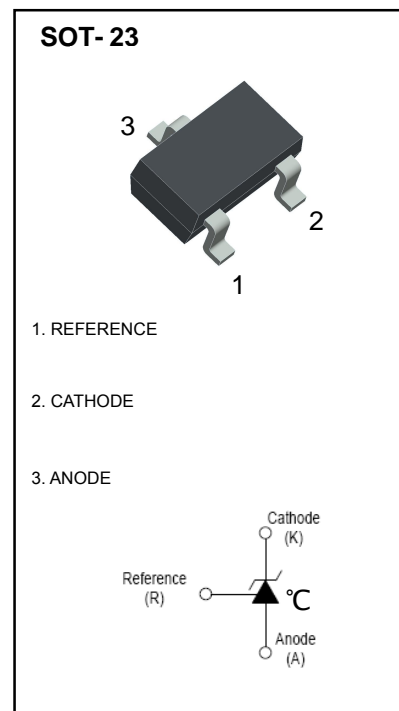

Applications

- Shunt Regulator
- High-Current Shunt Regulator
- Precision Current Limiter

Marking

- 431

Limiting Values (Absolute Maximum Rating)

Parameter	Symbol	Value	Unit
Cathode Voltage	V_{KA}	37	V
Cathode Current Range (Continuous)	I_{KA}	-100~+150	mA
Reference Input Current Range	I_{ref}	0.05~+10	mA
Power Dissipation	P_D	300	mW
Thermal Resistance from Junction to Ambient	$R_{\theta JA}$	417	$^\circ\text{C}/\text{W}$
Operating Junction Temperature	T_j	150	$^\circ\text{C}$
Operating Ambient Temperature Range	T_{opr}	-25~+85	$^\circ\text{C}$
Storage temperature Range	T_{stg}	-65~+150	$^\circ\text{C}$

Electrical Characteristics ($T_A=25^\circ\text{C}$ unless otherwise noted)

Parameter	Symbol	Test conditions	Min	Typ	Max	Unit
Reference input voltage (Fig.1)	V_{ref}	$V_{\text{KA}}=V_{\text{REF}}, I_{\text{KA}}=10\text{mA}$	2.475	2.5	2.525	V
Deviation of reference input voltage over temperature (note) (Fig.1)	$\Delta V_{\text{ref}}/\Delta T$	$V_{\text{KA}}=V_{\text{REF}}, I_{\text{KA}}=10\text{mA}$ $T_{\text{MIN}}\leq T_a\leq T_{\text{MAX}}$		4.5	17	mV
Ratio of change in reference input voltage to the change in cathode voltage (Fig.2)	$\Delta V_{\text{ref}}/\Delta V_{\text{KA}}$	$I_{\text{KA}}=10\text{mA}$	$\Delta V_{\text{KA}}=10\text{V}\sim V_{\text{REF}}$	-1.0	-2.7	mV/V
			$\Delta V_{\text{KA}}=36\text{V}\sim 10\text{V}$	-0.5	-2.0	mV/V
Reference input current (Fig.2)	I_{ref}	$I_{\text{KA}}=10\text{mA}, R_1=10\text{k}\Omega$ $R_2=\infty$		1.5	4	μA
Deviation Of reference input current over full temperature range (Fig.2)	$\Delta I_{\text{ref}}/\Delta T$	$I_{\text{KA}}=10\text{mA}, R_1=10\text{k}\Omega$ $R_2=\infty$ $T_A=-25$ to 85°C		0.4	1.2	μA
Minimum cathode current for regulation (Fig.1)	$I_{\text{KA(min)}}$	$V_{\text{KA}}=V_{\text{REF}}$		0.45	1.0	mA
Off-state cathode Current (Fig.3)	$I_{\text{KA(OFF)}}$	$V_{\text{KA}}=36\text{V}, V_{\text{REF}}=0$		0.05	1.0	μA
Dynamic impedance	Z_{KA}	$V_{\text{KA}}=V_{\text{REF}}, I_{\text{KA}}=1$ to 100mA $f\leq 1.0\text{kHz}$		0.15	0.5	Ω

Note: $T_{\text{MIN}}=-25^\circ\text{C}$, $T_{\text{MAX}}=+85^\circ\text{C}$

CLASSIFICATION cZV_{ref}

Rank	*** 0.5%	*****1%
Range	2.487-2.513	2.475-2.525

Figure 1. Test Circuit for $V_{\text{KA}} = V_{\text{ref}}$

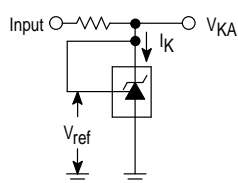

Figure 2. Test Circuit for $V_{\text{KA}} > V_{\text{ref}}$

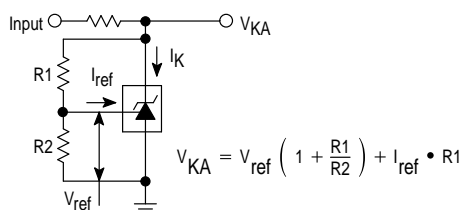
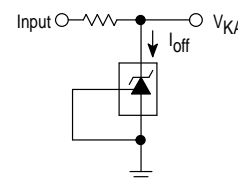
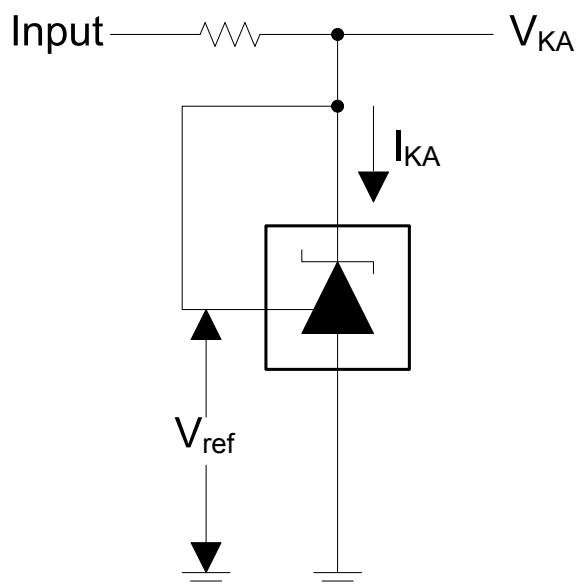
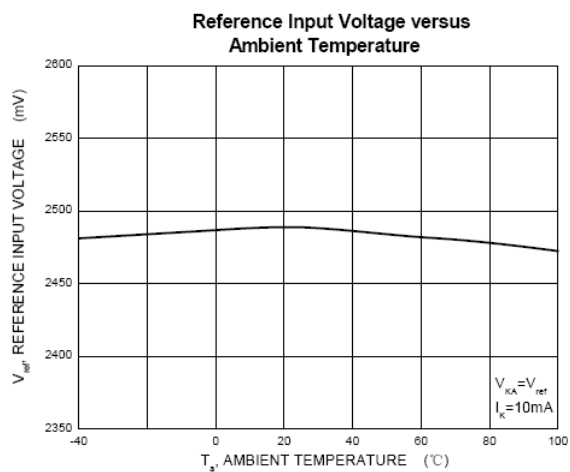
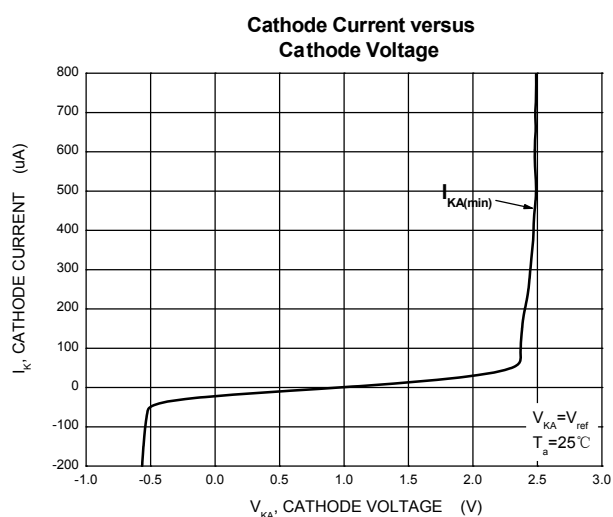
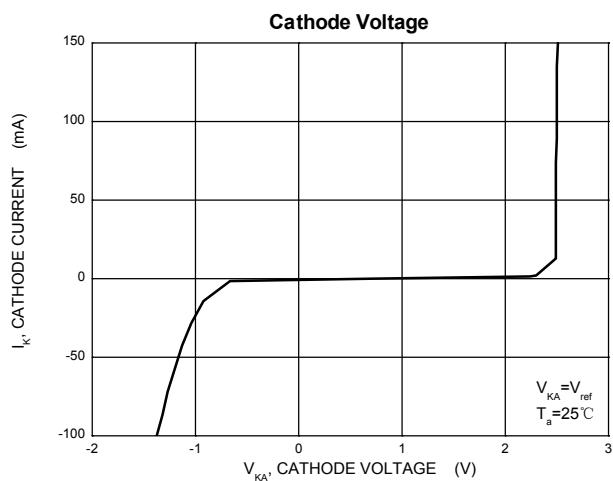

Figure 3. Test Circuit for I_{off}



Typical Characteristics



Test Circuit for $V_{KA} = V_{ref}$

Typical Characteristics

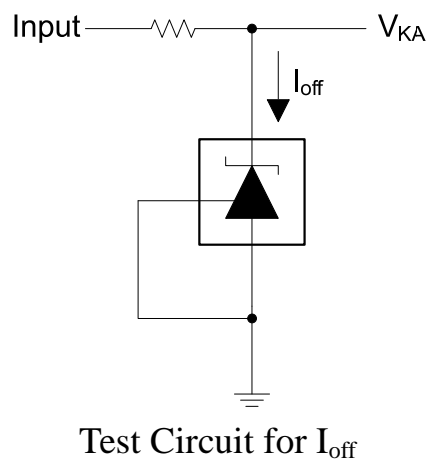
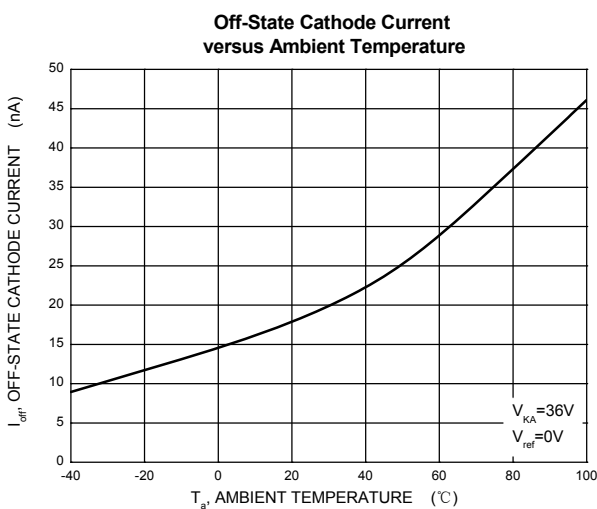
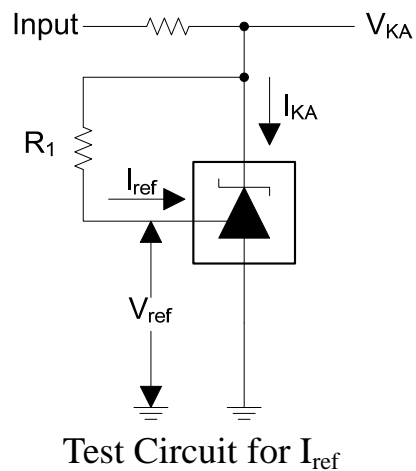
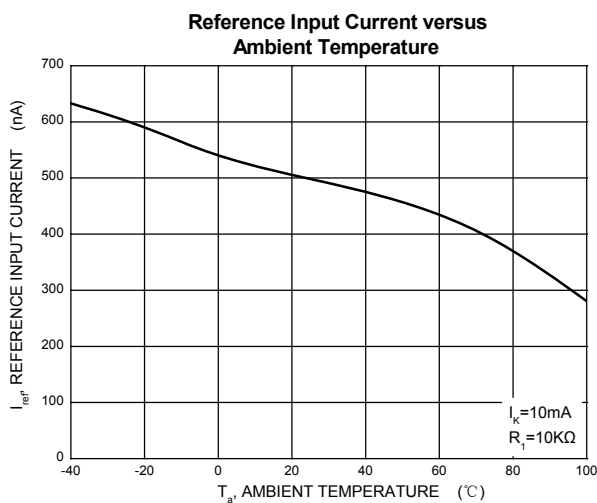
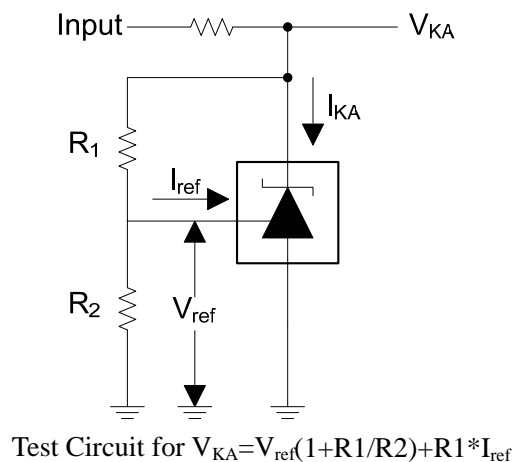
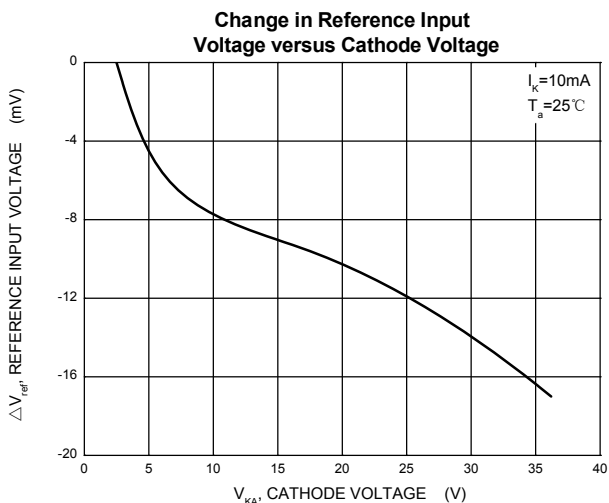

SOT-23 Package Outline Dimensions

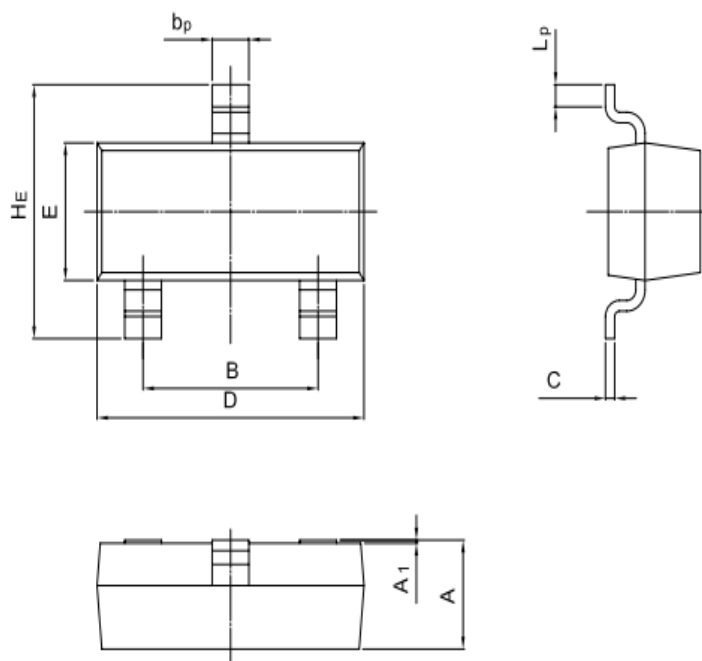

UNIT	A	B	bp	C	D	E	HE	A ₁	L _p
mm	1.40 0.95	2.04 1.78	0.50 0.35	0.19 0.08	3.10 2.70	1.65 1.20	3.00 2.20	0.100 0.013	0.50 0.20

SOT-23 Suggested Pad Layout

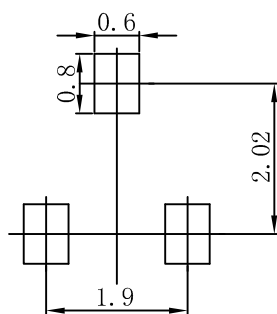

Note:

1. Controlling dimension: in millimeters.
2. General tolerance: $\pm 0.05\text{mm}$.
3. The pad layout is for reference purposes only.

NOTICE

JSMD reserve the right to make modifications, enhancements, improvements, corrections or other changes without further notice to any product herein. JSMD does not assume any liability arising out of the application or use of any product described herein.

Reel Taping Specifications For Surface Mount Devices-SOT-23

SOT-23 Embossed Carrier Tape

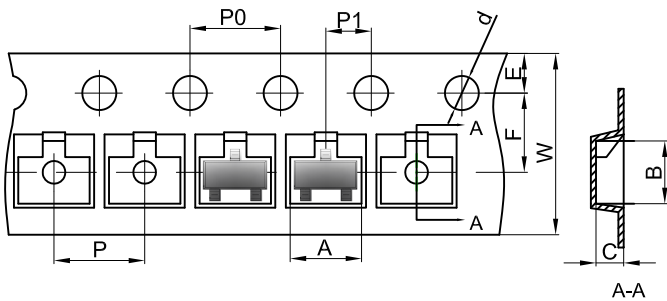

Packaging Description:

SOT-23 parts are shipped in tape. The carrier tape is made from a dissipative (carbon filled) polycarbonate resin. The cover tape is a multilayer film (Heat Activated Adhesive in nature) primarily composed of polyester film, adhesive layer, sealant, and anti-static sprayed agent. These reeled parts in standard option are shipped with 3,000 units per 7" or 17.8cm diameter reel. The reels are clear in color and is made of polystyrene plastic (anti-static coated).

Dimensions are in millimeter										
Pkg type	A	B	C	d	E	F	P0	P	P1	W
SOT-23	3.15	2.77	1.22	Ø1.50	1.75	3.50	4.00	4.00	2.00	8.00

SOT-23 Tape Leader and Trailer

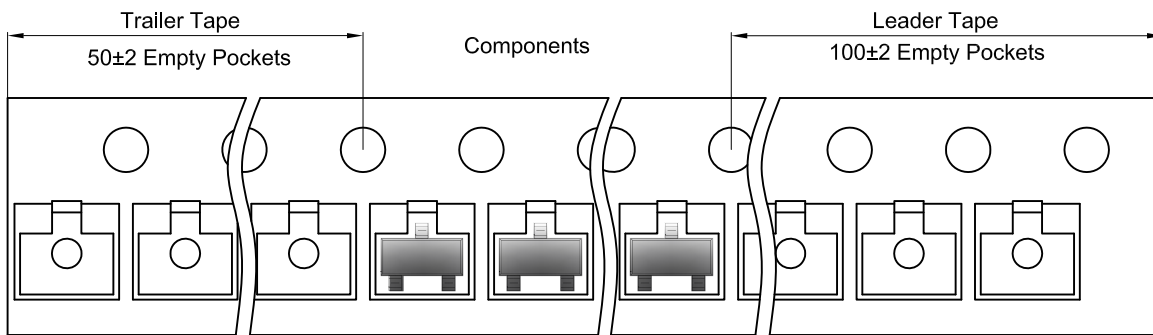

SOT-23 Reel

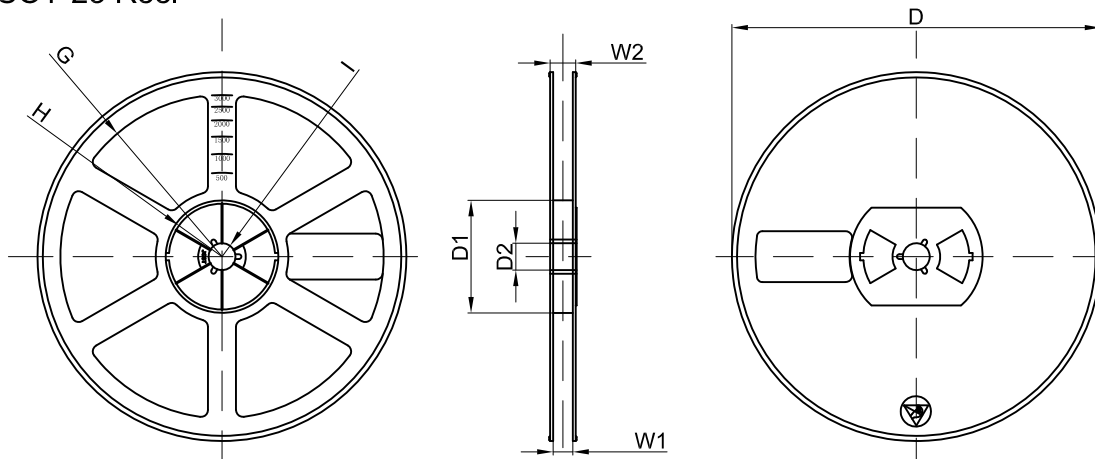

Dimensions are in millimeter								
Reel Option	D	D1	D2	G	H	I	W1	W2
7"Dia	Ø178.00	54.40	13.00	R78.00	R25.60	R6.50	9.50	12.30

REEL	Reel Size	Box	Box Size(mm)	Carton	Carton Size(mm)	G.W.(kg)
3000 pcs	7 inch	45,000 pcs	203×203×195	180,000 pcs	438×438×230	