

**REF05**

## **+5V Precision VOLTAGE REFERENCE (Guaranteed Long-Term Stability)**

### **FEATURES**

- **OUTPUT VOLTAGE:** +5V  $\pm 0.1\%$  max
- **GUARANTEED LONG-TERM STABILITY:** 25ppm/1000 hrs max
- **EXCELLENT TEMPERATURE STABILITY:** 8.5ppm/ $^{\circ}\text{C}$  max ( $-55^{\circ}\text{C}$  to  $+125^{\circ}\text{C}$ )
- **LOW NOISE:** 10 $\mu\text{V}$ p-p typ (0.1Hz to 10Hz)
- **EXCELLENT LINE REGULATION:** 0.008%/V max
- **EXCELLENT LOAD REGULATION:** 0.005%/mA max
- **LOW SUPPLY CURRENT:** 1.4mA max
- **SHORT-CIRCUIT PROTECTED**
- **WIDE SUPPLY RANGE:** 8VDC to 40VDC
- **HIGH LOAD DRIVING CAPACITY:** 20mA
- **PACKAGE:** Hermetic TO-99

### **APPLICATIONS**

- **PRECISION REGULATORS**
- **CONSTANT CURRENT SOURCE/SINK**
- **DIGITAL VOLTMETERS**
- **A/D AND D/A CONVERTERS**
- **PRECISION CALIBRATION STANDARD**
- **TEST EQUIPMENT**

### **DESCRIPTION**

The REF05 is a precision 5V voltage reference. The drift is laser trimmed to 8.5ppm/ $^{\circ}\text{C}$  max over the extended industrial and military temperature range. The REF05 provides a stable 5V output that can be externally adjusted over a  $\pm 6\%$  range with minimal effect on temperature stability. REF05 operates from a single supply with an input range of 8V to 40V with a very low current drain of 1mA, and excellent temperature stability due to an improved design. Excellent line and load regulation, low noise, low power, and low cost make the REF05 the best choice whenever a 5V voltage reference is required. The REF05 is an ideal choice for portable instrumentation, temperature transducers, A/D and D/A converters, and digital voltmeter.

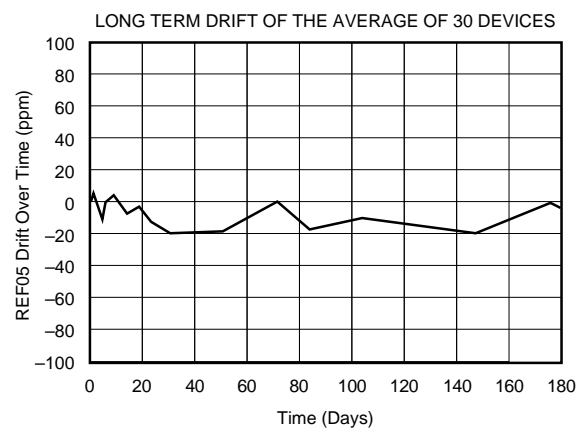

International Airport Industrial Park • Mailing Address: PO Box 11400 • Tucson, AZ 85734 • Street Address: 6730 S. Tucson Blvd. • Tucson, AZ 85706  
Tel: (520) 746-1111 • Twx: 910-952-1111 • Cable: BBRCORP • Telex: 066-6491 • FAX: (520) 889-1510 • Immediate Product Info: (800) 548-6132

# SPECIFICATIONS

## ELECTRICAL

T<sub>A</sub> = +25°C and V<sub>S</sub> = +15V power supply unless otherwise noted.

PARAMETER	CONDITIONS	REF05R			REF05S			UNITS
		MIN	TYP	MAX	MIN	TYP	MAX	
OUTPUT VOLTAGE ( $\Delta V_{OT}$ ) Change with Temperature <sup>(1,2)</sup> -55°C to +125°C	I <sub>L</sub> = 0mA	4.985	5.00	5.015	4.990	5.00	5.010	V
			0.05	0.27		0.05	0.15	%
OUTPUT VOLTAGE DRIFT <sup>(3)</sup> -55°C to +125°C (TCV <sub>O</sub> )			4	15		4	8.5	±ppm/°C
LONG TERM STABILITY <sup>(8)</sup>			10	25		10	25	±ppm/1K hrs
OUTPUT ADJUSTMENT RANGE	R <sub>POT</sub> = 10kΩ <sup>(6)</sup>	±3	±6		±3	±6		%
CHANGE IN V <sub>O</sub> TEMP COEFFICIENT WITH OUTPUT ADJUSTMENT (-55°C to +125°C)	R <sub>POT</sub> = 10kΩ <sup>(6)</sup>		0.7			0.7		ppm/%
OUTPUT VOLTAGE NOISE	0.1Hz to 10Hz <sup>(5)</sup>		4	10		4	10	μVp-p
LINE REGULATION <sup>(4)</sup> -55°C to +125°C	V <sub>IN</sub> = 8V to 33V V <sub>IN</sub> = 9V to 33V		0.006	0.010		0.006	0.010	%/V
			0.009	0.015		0.009	0.015	
LOAD REGULATION <sup>(4)</sup> -55°C to +125°C	I <sub>L</sub> = 0mA to +10mA I <sub>L</sub> = 0mA to +10mA		0.005	0.010		0.005	0.008	%/mA
			0.008	0.015		0.008	0.012	
TURN-ON SETTLING TIME	To ±0.1% of Final Value		5			5		μs
QUIESCENT CURRENT	No Load		1.0	1.4		1.0	1.4	mA
LOAD CURRENT (Source)		10	21		10	21		mA
LOAD CURRENT (Sink)		-0.3	-0.5		*	*		mA
SHORT-CIRCUIT CURRENT	V <sub>O</sub> = 0		30			30		mA
POWER DISSIPATION			15	21		15	21	mW
TEMPERATURE VOLTAGE OUTPUT <sup>(7)</sup>			630			630		mV
TEMPERATURE COEFFICIENT OF TEMPERATURE PIN VOLTAGE			2.1			2.1		mV/°C
TEMPERATURE RANGE Specification REF05R, S		-55		+125	*		*	°C

NOTES: (1)  $\Delta V_{OT}$  is defined as the absolute difference between the maximum output and the minimum output voltage over the specified temperature range expressed as a percentage of 5V:  $\Delta V_{OT} = \frac{|V_{MAX} - V_{MIN}|}{5V} \times 100$  (2)  $\Delta V_{OT}$  specification applies trimmed to +5.000V or untrimmed. (3) TCV<sub>O</sub> is defined as  $\Delta V_{OT}$  divided

by the temperature range. (4) Line and load regulation specifications include the effect of self heating. (5) Sample tested. (6) 10kΩ potentiometer connected between V<sub>O</sub> and ground with wiper connected to Trim pin. See Figure 1. (7) Pin 3 is insensitive to capacitive loading. The temperature voltage will be modified by 7mV for each μA of loading. (8) Samples tested for long term stability are tested with continuous power applied.

The information provided herein is believed to be reliable; however, BURR-BROWN assumes no responsibility for inaccuracies or omissions. BURR-BROWN assumes no responsibility for the use of this information, and all use of such information shall be entirely at the user's own risk. Prices and specifications are subject to change without notice. No patent rights or licenses to any of the circuits described herein are implied or granted to any third party. BURR-BROWN does not authorize or warrant any BURR-BROWN product for use in life support devices and/or systems.

### ABSOLUTE MAXIMUM RATINGS<sup>(1)</sup>

Input Voltage .....	+40V
Operating Temperature	
M .....	-55°C to +125°C
Storage Temperature Range	
M .....	-65°C to +150°C
Output Short Circuit Duration (to Ground or $V_{IN}$ ) .....	Indefinite
Junction Temperature .....	-65°C to +150°C
$\theta_{JA}$ M .....	150°C/W
Lead Temperature (soldering, 60s) .....	+300°C

### PIN CONFIGURATIONS

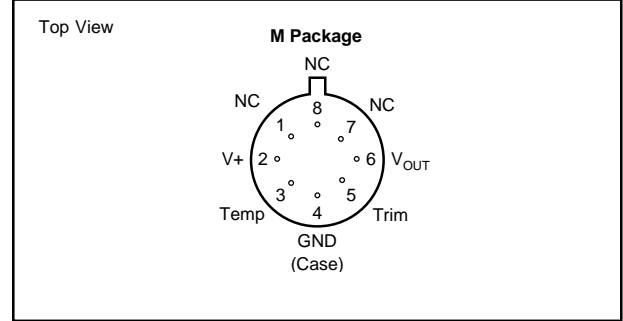

### PACKAGE INFORMATION<sup>(1)</sup>

MODEL	PACKAGE	PACKAGE DRAWING NUMBER
REF05RM	Metal TO-99	001
REF05SM	Metal TO-99	001

NOTE: (1) For detailed drawing and dimension table, please see end of data sheet, or Appendix D of Burr-Brown IC Data Book.

### ORDERING INFORMATION

MODEL	V <sub>OUT</sub> AT 25°C	MAX DRIFT (ppm/°C)	TEMPERATURE	PACKAGE
REF05RM	5V ±15mV	±15	-55°C to +125°C	Metal TO-99
REF05SM	5V ±10mV	±8.5	-55°C to +125°C	Metal TO-99

### PONY TAIL DRIFT PLOT

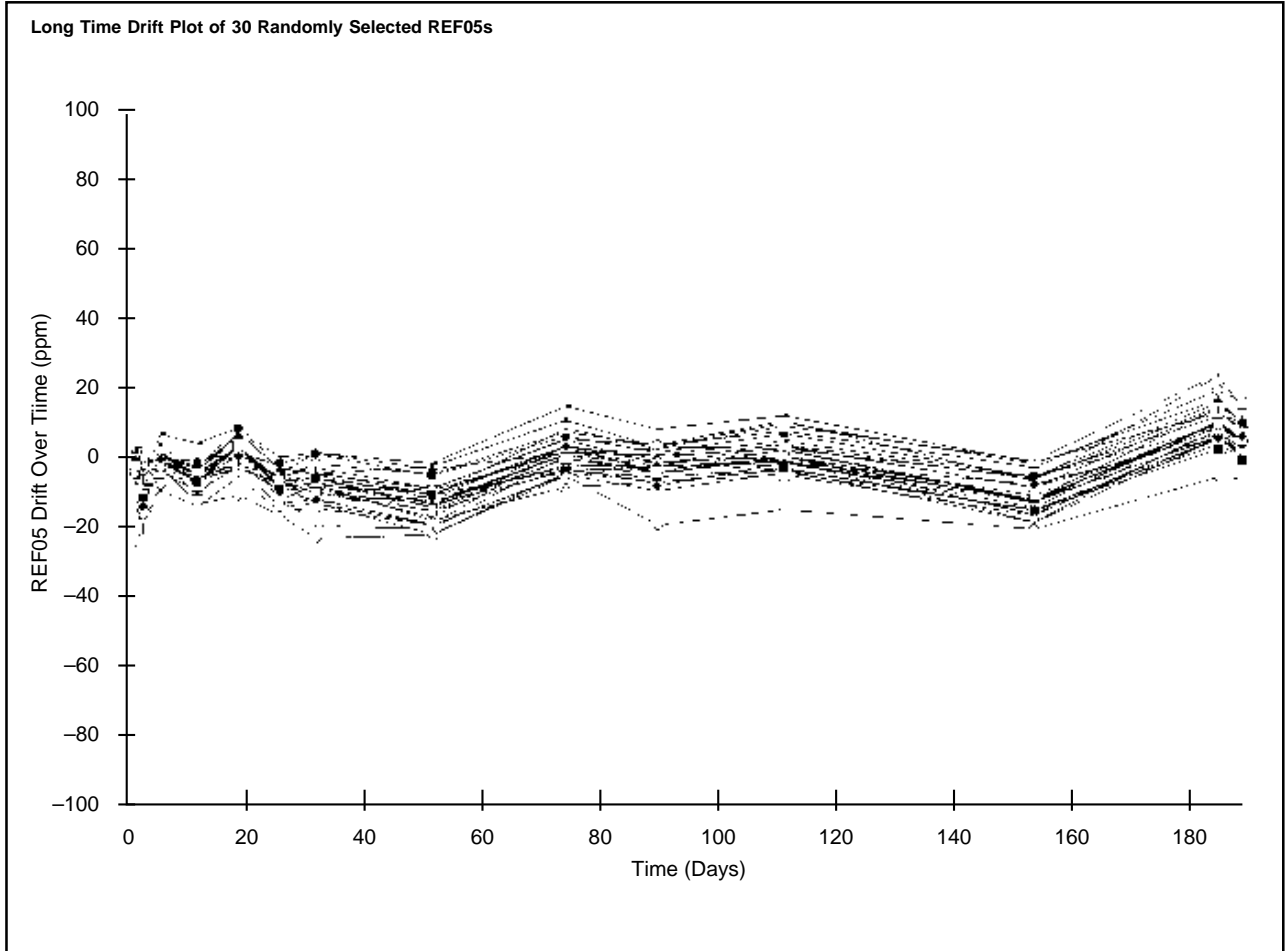

# TYPICAL PERFORMANCE CURVES

$T_A = +25^\circ\text{C}$  unless otherwise noted.

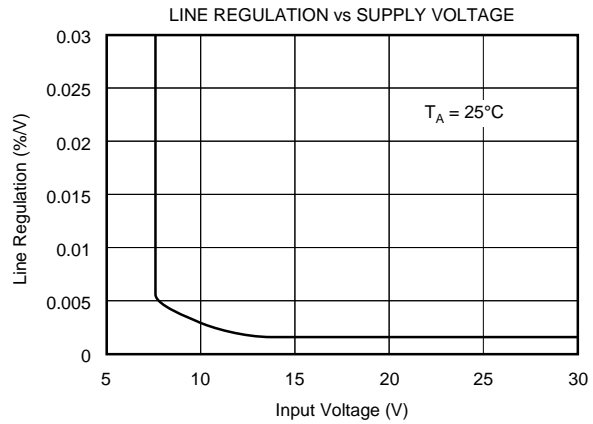
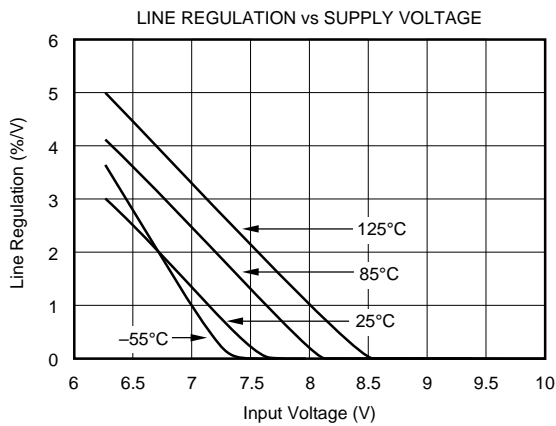
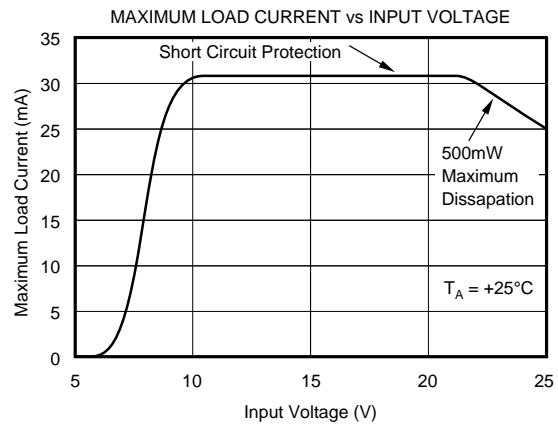
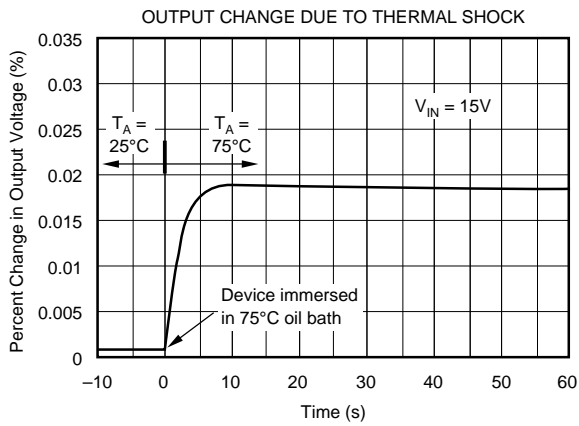
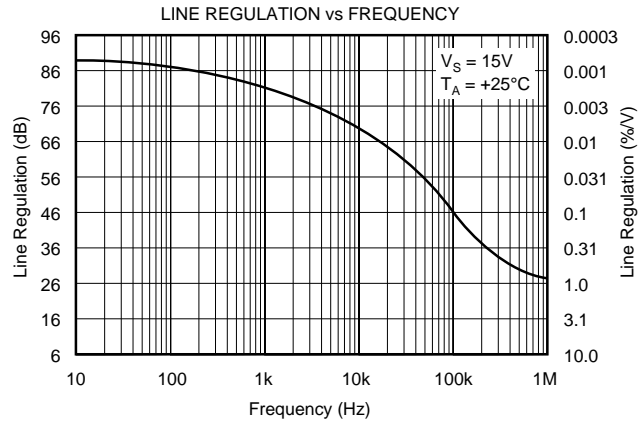
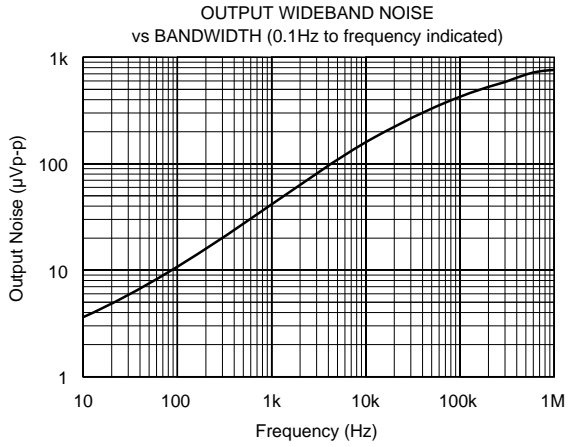

# TYPICAL PERFORMANCE CURVES (CONT)

$T_A = +25^\circ\text{C}$  unless otherwise noted.

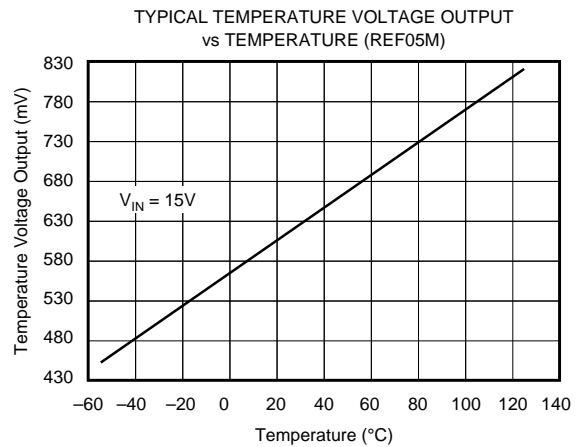
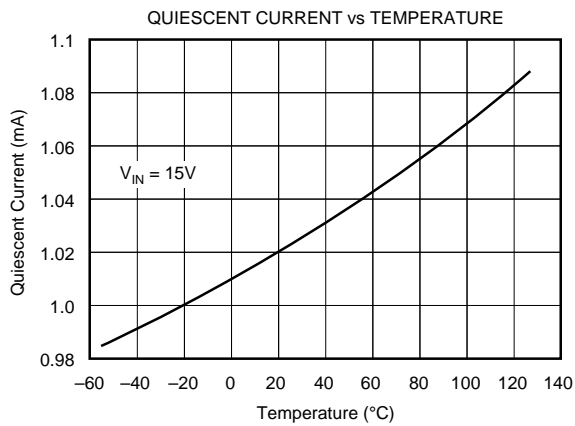
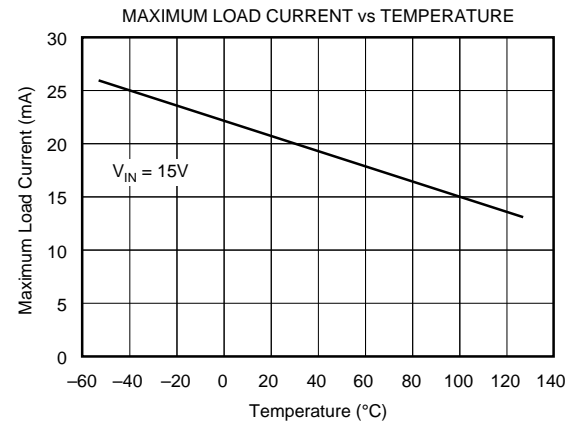
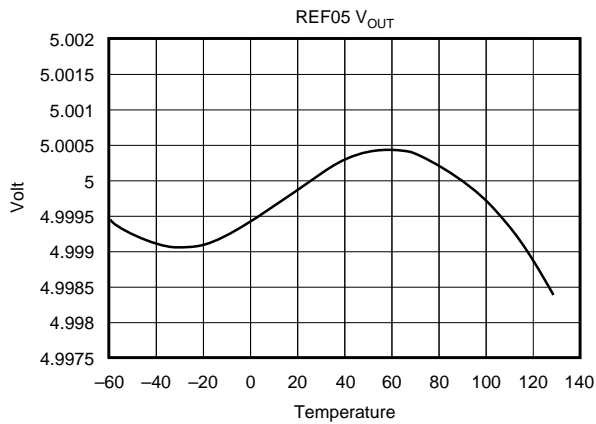
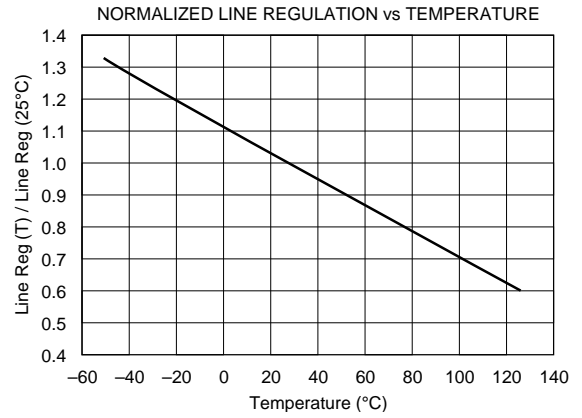
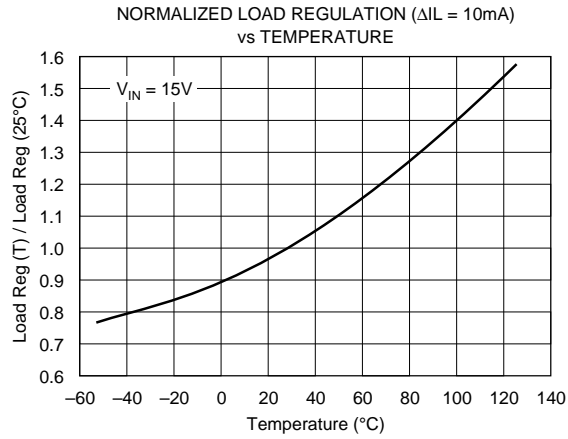

## OUTPUT ADJUSTMENT

The REF05 trim terminal can be used to adjust the voltage over a  $5V \pm 150mV$  range. This feature allows the system designer to trim system errors by setting the reference to a voltage other than 5V, including  $5.12V^{(1)}$  for binary applications (see Figure 1).

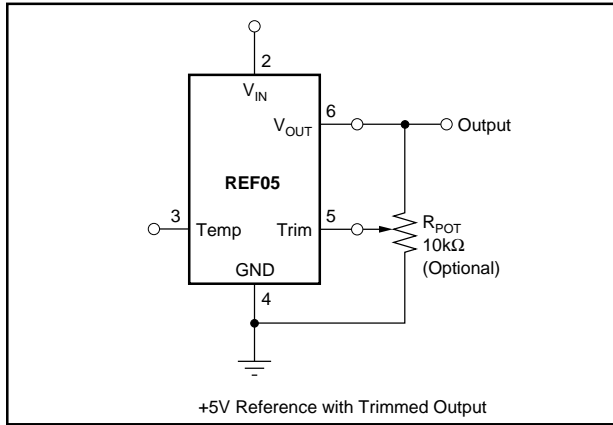

FIGURE 1.

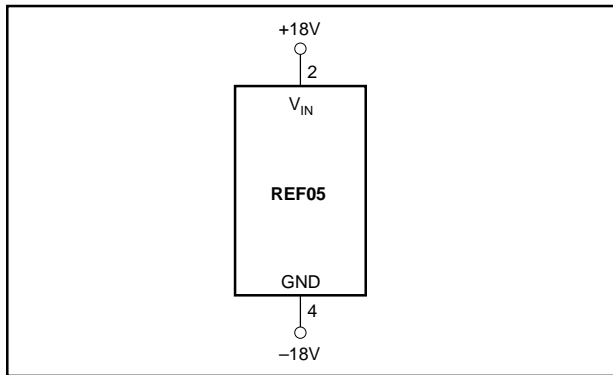

FIGURE 2. Burn-In Circuit.

## TYPICAL APPLICATIONS

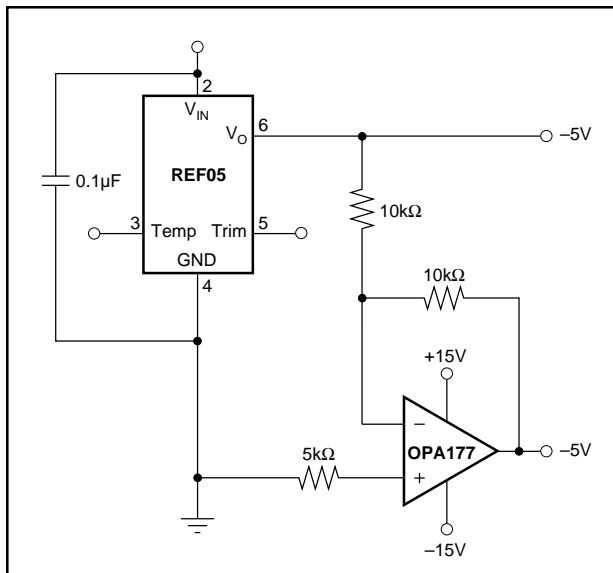

FIGURE 3. ±5V Precision Reference.

Adjustment of the output does not significantly affect the temperature performance of the device. The temperature coefficient change is approximately  $0.7ppm/^{\circ}C$  for  $100mV$  of output adjustment.

NOTE: (1) 20mV LSB for 8-bit applications.

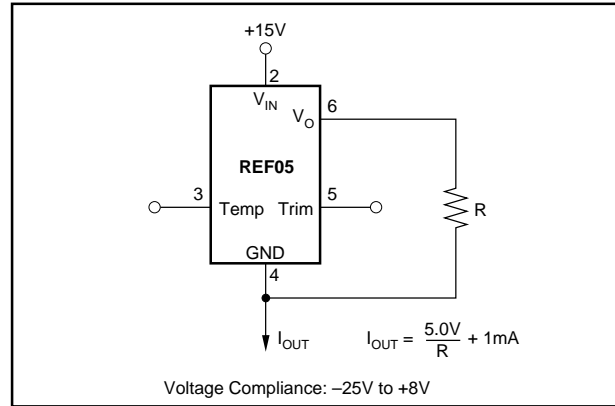

FIGURE 4. Current Source.

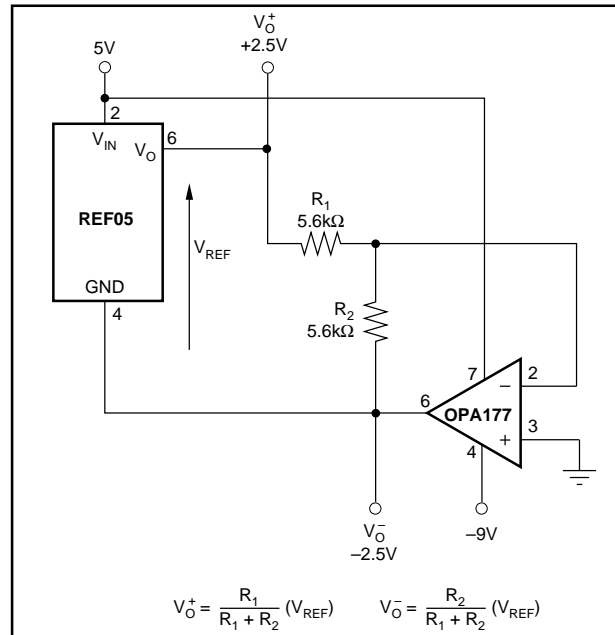

FIGURE 5. ±2.5V Precision Reference.

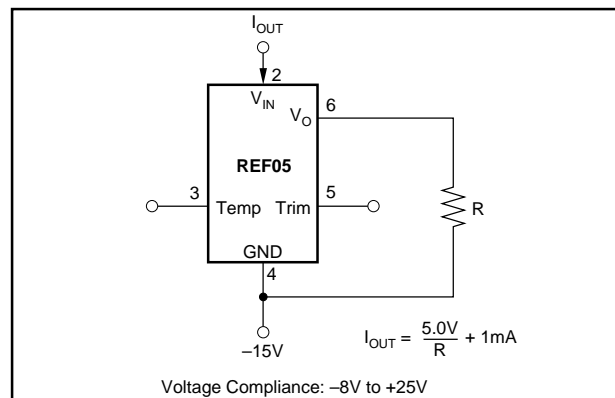

FIGURE 6. Current Sink.

This datasheet has been download from:

[www.datasheetcatalog.com](http://www.datasheetcatalog.com)

Datasheets for electronics components.