

PHILIPS

Data handbook



Electronic
components
and materials

**Semiconductors and
integrated circuits**

Part 4b September 1978

Photosensitive diodes and transistors

Light emitting diodes

Photocouplers

Infrared sensitive devices

Photoconductive devices

SEMICONDUCTORS AND INTEGRATED CIRCUITS

PART 4b — SEPTEMBER 1978
DEVICES FOR OPTOELECTRONICS

INDEX AND MAINTENANCE TYPE LIST

GENERAL

PHOTOSENSITIVE DIODES AND TRANSISTORS

LIGHT EMITTING DIODES

PHOTOCOUPLEDERS

INFRARED SENSITIVE DEVICES

PHOTOCONDUCTIVE DEVICES





DATA HANDBOOK SYSTEM

Our Data Handbook System is a comprehensive source of information on electronic components, sub-assemblies and materials; it is made up of three series of handbooks each comprising several parts.

ELECTRON TUBES

BLUE

SEMICONDUCTORS AND INTEGRATED CIRCUITS

RED

COMPONENTS AND MATERIALS

GREEN

The several parts contain all pertinent data available at the time of publication, and each is revised and reissued periodically.

Where ratings or specifications differ from those published in the preceding edition they are pointed out by arrows. Where application information is given it is advisory and does not form part of the product specification.

If you need confirmation that the published data about any of our products are the latest available, please contact our representative. He is at your service and will be glad to answer your inquiries.

This information is furnished for guidance, and with no guarantee as to its accuracy or completeness; its publication conveys no licence under any patent or other right, nor does the publisher assume liability for any consequence of its use; specifications and availability of goods mentioned in it are subject to change without notice; it is not to be reproduced in any way, in whole or in part without the written consent of the publisher.

October 1977

ELECTRON TUBES (BLUE SERIES)

Part 1a	December 1975	ET1a 12-75	Transmitting tubes for communication, tubes for r.f. heating Types PE05/25 to TBW15/25
Part 1b	August 1977	ET1b 08-77	Transmitting tubes for communication, tubes for r.f. heating, amplifier circuit assemblies
Part 2a	November 1977	ET2a 11-77	Microwave tubes Communication magnetrons, magnetrons for microwave heating, klystrons, travelling-wave tubes, diodes, triodes T-R switches
Part 2b	May 1978	ET2b 05-78	Microwave semiconductors and components Gunn, Impatt and noise diodes, mixer and detector diodes, backward diodes, varactor diodes, Gunn oscillators, sub- assemblies, circulators and isolators
Part 3	January 1975	ET3 01-75	Special Quality tubes, miscellaneous devices
Part 4	March 1975	ET4 03-75	Receiving tubes
Part 5a	March 1978	ET5a 03-78	Cathode-ray tubes Instrument tubes, monitor and display tubes, C.R. tubes for special applications
Part 5b	May 1975	ET5b 05-75	Camera tubes, image intensifier tubes
Part 6	January 1977	ET6 01-77	Products for nuclear technology Channel electron multipliers, neutron tubes, Geiger-Müller tubes
Part 7a	March 1977	ET7a 03-77	Gas-filled tubes Thyratrons, industrial rectifying tubes, ignitrons, high-voltage rectifying tubes
Part 7b	March 1977	ET7b 03-77	Gas-filled tubes Segment indicator tubes, indicator tubes, switching diodes, dry reed contact units
Part 8	May 1977	ET8 05-77	TV picture tubes
Part 9	March 1978	ET9 03-78	Photomultiplier tubes; phototubes

SEMICONDUCTORS AND INTEGRATED CIRCUITS (RED SERIES)

Part 1a August 1978	SC1a 08-78	Rectifier diodes, thyristors, triacs Rectifier diodes, voltage regulator diodes (> 1,5 W), transient suppressor diodes, rectifier stacks, thyristors, triacs
Part 1b May 1977	SC1b 05-77	Diodes Small signal germanium diodes, small signal silicon diodes, special diodes, voltage regulator diodes (< 1,5 W), voltage reference diodes, tuner diodes
Part 2 November 1977	SC2 11-77	Low-frequency and dual transistors
Part 3 January 1978	SC3 01-78	High-frequency, switching and field-effect transistors
Part 4a June 1976	SC4a 06-76	Special semiconductors* Transmitting transistors, field-effect transistors, dual transistors, microminiature devices for thick and thin-film circuits
Part 4b September 1978	SC4b 09-78	Devices for optoelectronics Photosensitive diodes and transistors, light emitting diodes, photocouplers, infrared sensitive devices, photoconductive devices
Part 4c July 1978	SC4c 07-78	Discrete semiconductors for hybrid thick and thin-film circuits
Part 5a November 1976	SC5a 11-76	Professional analogue integrated circuits
Part 5b March 1977	SC5b 03-77	Consumer integrated circuits Radio-audio, television
Part 6 October 1977	SC6 10-77	Digital integrated circuits LOCMOS HE4000B family
Signetics integrated circuits 1978		Bipolar and MOS memories Bipolar and MOS microprocessors Analogue circuits

* The most recent information on field-effect transistors can be found in SC3 01-78, on dual transistors in SC2 11-77, and on microminiature devices in SC4c 07-78.

COMPONENTS AND MATERIALS (GREEN SERIES)

Part 1	June 1977	CM1 06-77	Assemblies for industrial use High noise immunity logic FZ/30-series, counter modules 50-series, NORbits 60-series, 61-series, circuit blocks 90-series, circuit block CSA70(L), PLC modules, input/output devices, hybrid circuits, peripheral devices, ferrite core memory products
Part 2a	October 1977	CM2a 10-77	Resistors Fixed resistors, variable resistors, voltage dependent resistors (VDR), light dependent resistors (LDR), negative temperature coefficient thermistors (NTC), positive temperature coefficient thermistors (PTC), test switches
Part 2b	February 1978	CM2b 02-78	Capacitors Electrolytic and solid capacitors, film capacitors, ceramic capacitors, variable capacitors
Part 3	January 1977	CM3 01-77	Radio, audio, television Loudspeakers, components for black and white television, components for colour television
Part 3a	September 1978	CM3a 09-78	FM tuners, television tuners, surface acoustic wave filters
Part 4a	September 1978	CM4a 09-78	Soft ferrites Ferrites for radio, audio and television, beads and chokes, Ferroxcube potcores and square cores, Ferroxcube transformer cores
Part 4b	December 1976	CM4b 12-76	Piezoelectric ceramics, permanent magnet materials
Part 6	April 1977	CM6 04-77	Electric motors and accessories Small synchronous motors, stepper motors, miniature direct current motors
Part 7	September 1971	CM7 09-71	Circuit blocks Circuit blocks 100 kHz-series, circuit blocks 1-series, circuit blocks 10-series, circuit blocks for ferrite core memory drive
Part 8	February 1977	CM8 02-77	Variable mains transformers
Part 9	March 1976	CM9 03-76	Piezoelectric quartz devices
Part 10	April 1978	CM10 04-78	Connectors

INDEX OF TYPE NUMBERS

Data Handbooks SC1a to SC4c

The inclusion of a type number in this publication does not necessarily imply its availability.

type no.	part	section	type no.	part	section	type no.	part	section
AA119	1b	PC	BA217	1b	WD	BAW62	1b	WD
AAZ15	1b	GB	BA218	1b	WD	BAX12	1b	WD
AAZ17	1b	GB	BA219	1b	WD	BAX12A	1b	WD
AAZ18	1b	GB	BA220	1b	WD	BAX13	1b	WD
AC125	2	LF	BA221	1b	WD	BAX14	1b	WD
AC126	2	LF	BA222	1b	WD	BAX14A	1b	WD
AC127	2	LF	BA243	1b	T	BAX15	1b	WD
AC128	2	LF	BA244	1b	T	BAX16	1b	WD
AC128/01	2	LF	BA280	1b	T	BAX17	1b	WD
AC132	2	LF	BA314	1b	Vrg	BAX18	1b	WD
AC187	2	LF	BA314A	1b	Vrg	BAX18A	1b	WD
AC187/01	2	LF	BA315	1b	Vrg	BB105A	1b	T
AC188	2	LF	BA316	1b	WD	BB105B	1b	T
AC188/01	2	LF	BA317	1b	WD	BB105G	1b	T
AD161	2	P	BA318	1b	WD	BB106	1b	T
AD162	2	P	BA379	1b	T	BB110B	1b	T
AF367	3	HFSW	BAS16	4c	Mm	BB110G	1b	T
ASZ15	2	P	BAT17	4c	Mm	BB117	1b	T
ASZ16	2	P	BAT18	4c	Mm	BB119	1b	T
ASZ17	2	P	BAV10	1b	WD	BB204B	1b	T
ASZ18	2	P	BAV18	1b	WD	BB204G	1b	T
BA100	1b	AD	BAV19	1b	WD	BB205A	1b	T
BA102	1b	T	BAV20	1b	WD	BB205B	1b	T
BA145	1a	R	BAV21	1b	WD	BB205G	1b	T
BA148	1a	R	BAV45	1b	Sp	BBY31	4c	Mm
BA157	1a	R	BAV70	4c	Mm	BC107	2	LF
BA158	1a	R	BAV99	4c	Mm	BC108	2	LF
BA159	1a	R	BAW21A	1b	WD	BC109	2	LF
BA182	1b	T	BAW21B	1b	WD	BC140	2	LF
BA216	1b	WD	BAW56	4c	Mm	BC141	2	LF

AD = Silicon alloyed diodes
 GB = Germanium gold bonded diodes
 HFSW = High-frequency and switching transistors
 LF = Low-frequency transistors
 Mm = Discrete semiconductors for hybrid
 thick and thin-film circuits
 P = Low-frequency power transistors

PC = Germanium point contact diodes
 R = Rectifier diodes
 Sp = Special diodes
 T = Tuner diodes
 Vrg = Voltage regulator diodes
 WD = Silicon whiskerless diodes

INDEX

type no.	part	section	type no.	part	section	type no.	part	section
BC146	2	LF	BCW30;R	4c	Mm	BD135	2	P
BC147	2	LF	BCW31;R	4c	Mm	BD136	2	P
BC148	2	LF	BCW32;R	4c	Mm	BD137	2	P
BC149	2	LF	BCW33;R	4c	Mm	BD138	2	P
BC157	2	LF	BCW69;R	4c	Mm	BD139	2	P
BC158	2	LF	BCW70;R	4c	Mm	BD140	2	P
BC159	2	LF	BCW71;R	4c	Mm	BD181	2	P
BC160	2	LF	BCW72;R	4c	Mm	BD182	2	P
BC161	2	LF	BCX17;R	4c	Mm	BD183	2	P
BC177	2	LF	BCX18;R	4c	Mm	BD201	2	P
BC178	2	LF	BCX19;R	4c	Mm	BD202	2	P
BC179	2	LF	BCX20;R	4c	Mm	BD203	2	P
BC200	2	LF	BCX51	4c	Mm	BD204	2	P
BC264A	3	FET	BCX52	4c	Mm	BD226	2	P
BC264B	3	FET	BCX53	4c	Mm	BD227	2	P
BC264C	3	FET	BCX54	4c	Mm	BD228	2	P
BC264D	3	FET	BCX55	4c	Mm	BD229	2	P
BC327	2	LF	BCX56	4c	Mm	BD230	2	P
BC328	2	LF	BCY30A	2	LF	BD231	2	P
BC337	2	LF	BCY31A	2	LF	BD232	2	P
BC338	2	LF	BCY32A	2	LF	BD233	2	P
BC368	2	LF	BCY33A	2	LF	BD234	2	P
BC369	2	LF	BCY34A	2	LF	BD235	2	P
BC546	2	LF	BCY55	2	DT	BD236	2	P
BC547	2	LF	BCY56	2	LF	BD237	2	P
BC548	2	LF	BCY57	2	LF	BD238	2	P
BC549	2	LF	BCY58	2	LF	BD262	2	P
BC550	2	LF	BCY59	2	LF	BD262A	2	P
BC556	2	LF	BCY70	2	LF	BD262B	2	P
BC557	2	LF	BCY71	2	LF	BD263	2	P
BC558	2	LF	BCY72	2	LF	BD263A	2	P
BC559	2	LF	BCY78	2	LF	BD263B	2	P
BC560	2	LF	BCY79	2	LF	BD266	2	P
BC635	2	LF	BCY87	2	DT	BD266A	2	P
BC636	2	LF	BCY88	2	DT	BD266B	2	P
BC637	2	LF	BCY89	2	DT	BD267	2	P
BC638	2	LF	BD115	2	P	BD267A	2	P
BC639	2	LF	BD131	2	P	BD267B	2	P
BC640	2	LF	BD132	2	P	BD291	2	P
BCW29;R	4c	Mm	BD133	2	P	BD292	2	P

DT = Dual transistors
 FET = Field-effect transistors
 LF = Low-frequency transistors

Mm = Discrete semiconductors for hybrid
 thick and thin-film circuits
 P = Low-frequency power transistors

type no.	part	section	type no.	part	section	type no.	part	section
BD293	2	P	BDX64A	2	P	BF195	3	HFSW
BD294	2	P	BDX64B	2	P	BF196	3	HFSW
BD329	2	P	BDX65	2	P	BF197	3	HFSW
BD330	2	P	BDX65A	2	P	BF198	3	HFSW
BD331	2	P	BDX65B	2	P	BF199	3	HFSW
BD332	2	P	BDX66	2	P	BF200	3	HFSW
BD333	2	P	BDX66A	2	P	BF240	3	HFSW
BD334	2	P	BDX66B	2	P	BF241	3	HFSW
BD335	2	P	BDX67	2	P	BF245A	3	FET
BD336	2	P	BDX67A	2	P	BF245B	3	FET
BD433	2	P	BDX67B	2	P	BF245C	3	FET
BD434	2	P	BDX77-	2	P	BF256A	3	FET
BD435	2	P	BDX78	2	P	BF256B	3	FET
BD436	2	P	BDX91	2	P	BF256C	3	FET
BD437	2	P	BDX92	2	P	BF324	3	HFSW
BD438	2	P	BDX93	2	P	BF327	3	FET
BD645	2	P	BDX94	2	P	BF336	3	HFSW
BD646	2	P	BDX95	2	P	BF337	3	HFSW
BD647	2	P	BDX96	2	P	BF338	3	HFSW
BD648	2	P	BDY20	2	P	BF362	3	HFSW
BD649	2	P	BDY90	2	P	BF363	3	HFSW
BD650	2	P	BDY91	2	P	BF422	3	HFSW
BD675	2	P	BDY92	2	P	BF423	3	HFSW
BD676	2	P	BDY93	2	P	BF450	3	HFSW
BD677	2	P	BDY94	2	P	BF451	3	HFSW
BD678	2	P	BDY96	2	P	BF457	3	HFSW
BD679	2	P	BDY97	2	P	BF458	3	HFSW
BD680	2	P	BF115	3	HFSW	BF459	3	HFSW
BD681	2	P	BF167	3	HFSW	BF480	3	HFSW
BD682	2	P	BF173	3	HFSW	BF494	3	HFSW
BDX35	2	P	BF177	3	HFSW	BF495	3	HFSW
BDX36	2	P	BF178	3	HFSW	BF550;R	4c	Mm
BDX37	2	P	BF179	3	HFSW	BF622	4c	Mm
BDX62	2	P	BF180	3	HFSW	BF623	4c	Mm
BDX62A	2	P	BF181	3	HFSW	BFQ10	3	FET
BDX62B	2	P	BF182	3	HFSW	BFQ11	3	FET
BDX63	2	P	BF183	3	HFSW	BFQ12	3	FET
BDX63A	2	P	BF184	3	HFSW	BFQ13	3	FET
BDX63B	2	P	BF185	3	HFSW	BFQ14	3	FET
BDX64	2	P	BF194	3	HFSW	BFQ15	3	FET

FET = Field-effect transistors
HFSW = High-frequency and switching transistors
Mm = Discrete semiconductors for hybrid
thick and thin-film circuits

P = Low-frequency power transistors

INDEX

type no.	part	section	type no.	part	section	type no.	part	section
BFQ16	3	FET	BFW11	3	FET	BLW64	4a	Tra
BFQ17	4c	Mm	BFW12	3	FET	BLW75	4a	Tra
BFQ18A	4c	Mm	BFW13	3	FET	BLX13	4a	Tra
BFQ19	4c	Mm	BFW16A	3	HFSW	BLX14	4a	Tra
BFQ23	3	HFSW	BFW17A	3	HFSW	BLX15	4a	Tra
BFQ24	3	HFSW	BFW30	3	HFSW	BLX65	4a	Tra
BFQ32	3	HFSW	BFW45	3	HFSW	BLX66	4a	Tra
BFQ34	3	HFSW	BFW61	3	FET	BLX67	4a	Tra
BFR29	3	FET	BFW92	3	HFSW	BLX68	4a	Tra
BFR30	4c	Mm	BFW93	3	HFSW	BLX69A	4a	Tra
BFR31	4c	Mm	BFX34	3	HFSW	BLX91A	4a	Tra
BFR49	3	HFSW	BFX89	3	HFSW	BLX92A	4a	Tra
BFR53;R	4c	Mm	BFY50	3	HFSW	BLX93A	4a	Tra
BFR64	3	HFSW	BFY51	3	HFSW	BLX94A	4a	Tra
BFR65	3	HFSW	BFY52	3	HFSW	BLX95	4a	Tra
BFR84	3	FET	BFY55	3	HFSW	BLX96	4a	Tra
BFR90	3	HFSW	BFY90	3	HFSW	BLX97	4a	Tra
BFR91	3	HFSW	BG1895-			BLX98	4a	Tra
BFR92;R	4c	Mm	541	1a	R	BLY87A	4a	Tra
BFR93;R	4c	Mm				BLY88A	4a	Tra
BFR94	3	HFSW	BG1895-			BLY89A	4a	Tra
BFR95	3	HFSW	641	1a	R	BLY90	4a	Tra
BFR96	3	HFSW	BG1897-			BLY91A	4a	Tra
BFS17;R	4c	Mm	541	1a	R	BLY92A	4a	Tra
BFS18;R	4c	Mm				BLY93A	4a	Tra
BFS19;R	4c	Mm	BG1897-			BLY94	4a	Tra
BFS20;R	4c	Mm	542	1a	R	BPW22	4b	PDT
BFS21	3	FET	BG1897-			BPW34	4b	PDT
BFS21A	3	FET	641	1a	R	BPX25	4b	PDT
BFS22A	4a	Tra				BPX29	4b	PDT
BFS23A	4a	Tra	BG1897-			BPX40	4b	PDT
BFS28	3	FET	642	1a	R	BPX41	4b	PDT
BFT24	3	HFSW	BG1898-			BPX42	4b	PDT
BFT25;R	4c	Mm	541	1a	R	BPX47A	4b	PDT
BFT44	3	HFSW				BPX70	4b	PDT
BFT45	3	HFSW	BG1898-			BPX71	4b	PDT
BFT46	4c	Mm	641	1a	R	BPX72	4b	PDT
BFT92;R	4c	Mm	BGY37	3	HFSW	BPX94	4b	PDT
BFT93;R	4c	Mm	BLW60	4a	Tra	BPX95B	4b	PDT
BFW10	3	FET				BR100	1a	Th

FET = Field-effect transistors
HFSW = High-frequency and switching transistors
Mm = Discrete semiconductors for hybrid
thick and thin-film circuits
PDT = Photodiodes or transistors

R = Rectifier diodes
Th = Thyristors
Tra = Transmitting transistors

type no.	part	section	type no.	part	section	type no.	part	section
BR101	3	HFSW	BSW68	3	HFSW	BU133	2	P
BRY39	1a	Th	BSX19	3	HFSW	BU204	2	P
BRY39			BSX20	3	HFSW	BU205	2	P
(SCS)	3	HFSW	BSX21	3	HFSW	BU206	2	P
BRY39			BSX45	3	HFSW	BU207A	2	P
(PUT)	3	HFSW	BSX46	3	HFSW	BU208A	2	P
BRY61	4c	Mm	BSX47	3	HFSW	BU209A	2	P
BSR12;R	4c	Mm	BSX59	3	HFSW	BU326A	2	P
BSR30	4c	Mm	BSX60	3	HFSW	BUX80	2	P
BSR31	4c	Mm	BSX61	3	HFSW	BUX81	2	P
BSR32	4c	Mm	BT126	1a	Th	BUX82	2	P
BSR33	4c	Mm	BT128 +	1a	Th	BUX83	2	P
BSR40	4c	Mm	BT129 +	1a	Th	BUX84	2	P
BSR41	4c	Mm	BT137 +	1a	Tri	BUX85	2	P
BSR42	4c	Mm	BT138 +	1a	Tri	BUX86	2	P
BSR43	4c	Mm	BT139 +	1a	Tri	BUX87	2	P
BSR56	4c	Mm	BT151 +	1a	Th	BY126	1a	R
BSR57	4c	Mm	BTW23 +	1a	Th	BY127	1a	R
BSR58	4c	Mm	BTW24 +	1a	Th	BY164	1a	R
BSS38	3	HFSW	BTW30 +	1a	Th	BY176	1a	R
BSS50	3	HFSW	BTW31 +	1a	Th	BY179	1a	R
BSS51	3	HFSW	BTW33 +	1a	Th	BY184	1a	R
BSS52	3	HFSW	BTW34 +	1a	Tri	BY187	1a	R
BSS60	3	HFSW	BTW38 +	1a	Th	BY188 +	1a	R
BSS61	3	HFSW	BTW40 +	1a	Th	BY206	1a	R
BSS63;R	4c	Mm	BTW41 +	1a	Tri	BY207	1a	R
BSS64;R	4c	Mm	BTW42 +	1a	Th	BY208 +	1a	R
BSS68	3	HFSW	BTW43 +	1a	Tri	BY209	1a	R
BSV15	3	HFSW	BTW45 +	1a	Th	BY223	1a	R
BSV16	3	HFSW	BTW47 +	1a	Th	BY224 +	1a	R
BSV17	3	HFSW	BTW92 +	1a	Th	BY225 +	1a	R
BSV52;R	4c	Mm	BTX18 +	1a	Th	BY226	1a	R
BSV64	3	HFSW	BTX94 +	1a	Tri	BY227	1a	R
BSV78	3	FET	BTY79 +	1a	Th	BY228	1a	R
BSV79	3	FET	BTY87 +	1a	Th	BY277 +	1a	R
BSV80	3	FET	BTY91 +	1a	Th	BY406	1a	R
BSV81	3	FET	BU105	2	P	BY407	1a	R
BSW41A	3	HFSW	BU108	2	P	BY409	1a	R
BSW66	3	HFSW	BU126	2	P	BY409A	1a	R
BSW67	3	HFSW	BU132	2	P	BY476	1a	R

+ = series.

FET = Field-effect transistors
HFSW = High-frequency and switching transistors
Mm = Discrete semiconductors for hybrid
thick and thin-film circuits
P = Low-frequency power transistors
R = Rectifier diodes

Th = Thyristors
Tri = Triacs

INDEX

type no.	part	section	type no.	part	section	type no.	part	section
BY476A	1a	R	BZV14	1b	Vrf	BZZ27	1a	Vrg
BY477	1a	R	BZV15 +	1a	Vrg	BZZ28	1a	Vrg
BY478	1a	R	BZV38	1b	Vrf	BZZ29	1a	Vrg
BYW19 +	1a	R	BZW10	1a	TS	CNY22	4b	PhC
BYW29 +	1a	R	BZW70 +	1a	TS	CNY23	4b	PhC
BYW30 +	1a	R	BZW86 +	1a	TS	CNY42	4b	PhC
BYW31 +	1a	R	BZW91 +	1a	TS	CNY43	4b	PhC
BYW54	1a	R	BZW93 +	1a	TS	CNY44	4b	PhC
BYW55	1a	R	BZW95 +	1a	TS	CNY46	4b	PhC
BYW56	1a	R	BZW96 +	1a	TS	CNY47	4b	PhC
BYW92 +	1a	R	BZX55 +	1b	Vrg	CNY47A	4b	PhC
BYX10	1a	R	BZX61 +	1b	Vrg	CNY48	4b	PhC
BYX22 +	1a	R	BZX70 +	1a	Vrg			
BYX25 +	1a	R	BZX75 +	1b	Vrg			
BYX29 +	1a	R	BZX79 +	1b	Vrg			
BYX30 +	1a	R	BZX84 +	4c	Mm	CQY11B	4b	LED
BYX32 +	1a	R	BZX87 +	1b	Vrg	CQY11C	4b	LED
BYX35	1a	R	BZX90	1b	Vrf	CQY24A	4b	LED
BYX36 +	1a	R	BZX91	1b	Vrf	CQY46A	4b	LED
BYX38 +	1a	R	BZX92	1b	Vrf	CQY47A	4b	LED
BYX39 +	1a	R	BZX93	1b	Vrf	CQY49B	4b	LED
BYX42 +	1a	R	BZY78	1b	Vrf	CQY49C	4b	LED
BYX45 +	1a	R	BZY88 +	1b	Vrg	CQY50	4b	LED
BYX46 +	1a	R	BZY91 +	1a	Vrg	CQY52	4b	LED
BYX49 +	1a	R	BZY93 +	1a	Vrg	CQY54	4b	LED
BYX50 +	1a	R	BZY95 +	1a	Vrg	CQY58	4b	LED
BYX52 +	1a	R	BZY96 +	1a	Vrg			
BYX55 +	1a	R	BZZ14	1a	Vrg			
BYX56 +	1a	R	BZZ15	1a	Vrg			
BYX71 +	1a	R	BZZ16	1a	Vrg			
BYX90	1a	R	BZZ17	1a	Vrg			
BYX91 +	1a	R	BZZ18	1a	Vrg			
BYX96 +	1a	R	BZZ19	1a	Vrg			
BYX97 +	1a	R	BZZ20	1a	Vrg	CQY88	4b	LED
BYX98 +	1a	R	BZZ21	1a	Vrg	CQY89	4b	LED
BYX99 +	1a	R	BZZ22	1a	Vrg	CQY94	4b	LED
BZV10	1b	Vrf	BZZ23	1a	Vrg	CQY95	4b	LED
BZV11	1b	Vrf	BZZ24	1a	Vrg	CQY96	4b	LED
BZV12	1b	Vrf	BZZ25	1a	Vrg	CQY97	4b	LED
BZV13	1b	Vrf	BZZ26	1a	Vrg	OA47	1b	GB

+ = series.

GB = Germanium gold bonded diodes
 LED = Light-emitting diodes
 Mm = Discrete semiconductors for hybrid
 thick and thin-film circuits

PhC = Photocouplers
 R = Rectifier diodes
 TS = Transient suppressor diodes
 Vrf = Voltage reference diodes
 Vrg = Voltage regulator diodes

type no.	part	section	type no.	part	section	type no.	part	section
OA90	1b	PC	1N827	1b	Vrf	1N5744B	1b	Vrg
OA91	1b	PC	1N829	1b	Vrf	1N5745B	1b	Vrg
OA95	1b	PC	1N914	1b	WD	1N5746B	1b	Vrg
OA200	1b	AD	1N914A	1b	WD	1N5747B	1b	Vrg
OA202	1b	AD	1N916	1b	WD	1N5748B	1b	Vrg
ORP10	4b	I	1N916A	1b	WD	1N5749B	1b	Vrg
ORP13	4b	I	1N916B	1b	WD	1N5750B	1b	Vrg
ORP23	4b	Ph	1N3879	1a	R	1N5751B	1b	Vrg
ORP52	4b	Ph	1N3880	1a	R	1N5752B	1b	Vrg
ORP60	4b	Ph	1N3881	1a	R	1N5753B	1b	Vrg
ORP61	4b	Ph	1N3882	1a	R	1N5754B	1b	Vrg
ORP62	4b	Ph	1N3889	1a	R	1N5755B	1b	Vrg
ORP66	4b	Ph	1N3890	1a	R	1N5756B	1b	Vrg
ORP68	4b	Ph	1N3891	1a	R	1N5757B	1b	Vrg
ORP69	4b	Ph	1N3892	1a	R	2N918	3	HFSW
OSB9110	1a	St	1N4009	1b	WD	2N929	2	LF
OSB9210	1a	St	1N4148	1b	WD	2N930	2	LF
OSB9310	1a	St	1N4150	1b	WD	2N1613	3	HFSW
OSB9410	1a	St	1N4151	1b	WD	2N1711	3	HFSW
OSM9110	1a	St	1N4154	1b	WD	2N1893	3	HFSW
OSM9210	1a	St	1N4446	1b	WD	2N2218	3	HFSW
OSM9310	1a	St	1N4448	1b	WD	2N2218A	3	HFSW
OSM9410	1a	St	1N5060	1a	R	2N2219	3	HFSW
OSS9110	1a	St	1N5061	1a	R	2N2219A	3	HFSW
OSS9210	1a	St	1N5062	1a	R	2N2221	3	HFSW
OSS9310	1a	St	1N5729B	1b	Vrg	2N2221A	3	HFSW
OSS9410	1a	St	1N5730B	1b	Vrg	2N2222	3	HFSW
RPY58A	4b	Ph	1N5731B	1b	Vrg	2N2222A	3	HFSW
RPY71	4b	Ph	1N5732B	1b	Vrg	2N2297	3	HFSW
RPY76A	4b	I	1N5733B	1b	Vrg	2N2368	3	HFSW
RPY82	4b	Ph	1N5734B	1b	Vrg	2N2369	3	HFSW
RPY84	4b	Ph	1N5735B	1b	Vrg	2N2369A	3	HFSW
RPY85	4b	Ph	1N5736B	1b	Vrg	2N2483	2	LF
RPY86	4b	I	1N5737B	1b	Vrg	2N2484	2	LF
RPY87	4b	I	1N5738B	1b	Vrg	2N2894	3	HFSW
RPY88	4b	I	1N5739B	1b	Vrg	2N2894A	3	HFSW
RPY89	4b	I	1N5740B	1b	Vrg	2N2904	3	HFSW
1N821	1b	Vrf	1N5741B	1b	Vrg	2N2904A	3	HFSW
1N823	1b	Vrf	1N5742B	1b	Vrg	2N2905	3	HFSW
1N825	1b	Vrf	1N5743B	1b	Vrg	2N2905A	3	HFSW



AD = Silicon alloyed diodes
 HFSW = High-frequency and switching transistors
 I = Infrared devices
 LF = Low-frequency transistors
 PC = Germanium point contact diodes
 Ph = Photoconductive devices

R = Rectifier diodes
 St = Rectifier stacks
 Vrf = Voltage reference diodes
 Vrg = Voltage regulator diodes
 WD = Silicon whiskerless diodes

INDEX

type no.	part	section	type no.	part	section	type no.	part	section
2N2906	3	HFSW	40835	3	HFSW	56315	1a	DH
2N2906A	3	HFSW	40838	3	HFSW	56316	1a	A
2N2907	3	HFSW	56200	2,3,		56318	1a	DH
2N2907A	3	HFSW		4a	A	56319	1a	DH
2N3019	3	HFSW	56201	2	A	56326	2,3	A
2N3020	3	HFSW	56201c	2	A	56333	2,3	A
2N3055	2	P	56201d	2	A	56334	1a	DH
2N3375	4a	Tra	56201j	2	A	56337	1a	A
2N3442	2	P	56203	2	A	56339	2	A
2N3553	4a	Tra	56218	2,3,		56348	1a	DH
2N3632	4a	Tra		4a	A	56349	1a	DH
2N3823	3	FET	56230	1a	HE	56350	1a	DH
2N3866	4a	Tra	56231	1a	HE	56351	2	A
2N3924	4a	Tra	56233	1a	A	56352	2	A
2N3926	4a	Tra	56234	1a	A	56353	2	A
2N3927	4a	Tra	56245	2,3,		56354	2	A
2N3966	3	FET		4a	A	56356	2,3	A
2N4030	3	HFSW	56246	1a		56358	1a	A
2N4031	3	HFSW		to 4a	A	56359	2	A
2N4032	3	HFSW	56253	1a	DH	56359a	2	A
2N4033	3	HFSW	56256	1a	DH	56360	2	A
2N4036	3	HFSW	56261	2	A	56360a	2	A
2N4091	3	FET	56261a	2	A	56363	1a,2	A
2N4092	3	FET	56262A	1a	A	56364	1a,2	A
2N4093	3	FET	56263	1a		56366	1a	A
2N4347	2	P		to 4a	A			
2N4391	3	FET	56264A	1a	A	56367	2	A
2N4392	3	FET	56268	1a	DH	56368	2	A
2N4393	3	FET	56271	1a	DH	56369	2	A
2N4427	4a	Tra	56278	1a	DH			
2N4856	3	FET	56280	1a	DH			
2N4857	3	FET	56290	1a	HE			
2N4858	3	FET	56293	1a	HE			
2N4859	3	FET	56295	1a	A			
2N4860	3	FET	56299	1a	A			
2N4861	3	FET	56309B	1a	A			
2N5415	3	HFSW	56309R	1a	A			
2N5416	3	HFSW	56312	1a	DH			
.61SV	4b	I	56313	1a	DH			
40820	3	HFSW	56314	1a	DH			

A = Accessories
 DH = Diecast heatsinks
 FET = Field-effect transistors
 HE = Heatsink extrusions

HFSW = High-frequency and switching transistors
 I = Infrared devices
 P = Low-frequency power transistors
 Tra = Transmitting transistors

MAINTENANCE TYPE LIST

The type numbers listed below are not included in this handbook except for those marked with an asterisk.

Detailed information will be supplied on request.

BPX66P

OAP12

OCP70

* ORP23

* ORP52

RPY13





GENERAL

Type designation

Rating systems

Letter symbols

Definitions applying to photosensitive devices



PRO ELECTRON TYPE DESIGNATION CODE
FOR SEMICONDUCTOR DEVICES

This type designation code applies to discrete semiconductor devices — as opposed to integrated circuits —, multiples of such devices and semiconductor chips.

A basic type number consists of:

TWO LETTERS FOLLOWED BY A SERIAL NUMBER

FIRST LETTER

The first letter gives information about the material used for the active part of the devices.

- A. GERMANIUM or other material with band gap of 0,6 to 1,0 eV.
- B. SILICON or other material with band gap of 1,0 to 1,3 eV.
- C. GALLIUM-ARSENIDE or other material with band gap of 1,3 eV or more.
- R. COMPOUND MATERIALS (e.g. Cadmium-Sulphide).

SECOND LETTER

The second letter indicates the function for which the device is primarily designed.

- A. DIODE; signal, low power
- B. DIODE; variable capacitance
- C. TRANSISTOR; low power, audio frequency ($R_{th j-mb} > 15 \text{ }^{\circ}\text{C/W}$)
- D. TRANSISTOR; power, audio frequency ($R_{th j-mb} \leq 15 \text{ }^{\circ}\text{C/W}$)
- E. DIODE; tunnel
- F. TRANSISTOR; low power, high frequency ($R_{th j-mb} > 15 \text{ }^{\circ}\text{C/W}$)
- G. MULTIPLE OF DISSIMILAR DEVICES — MISCELLANEOUS; e.g. oscillator
- H. DIODE; magnetic sensitive
- L. TRANSISTOR; power, high frequency ($R_{th j-mb} \leq 15 \text{ }^{\circ}\text{C/W}$)
- N. PHOTO-COUPLER
- P. RADIATION DETECTOR; e.g. high sensitivity phototransistor
- Q. RADIATION GENERATOR; e.g. light-emitting diode (LED)
- R. CONTROL AND SWITCHING DEVICE; e.g. thyristor, low power ($R_{th j-mb} > 15 \text{ }^{\circ}\text{C/W}$)
- S. TRANSISTOR; low power, switching ($R_{th j-mb} > 15 \text{ }^{\circ}\text{C/W}$)
- T. CONTROL AND SWITCHING DEVICE; e.g. thyristor, power ($R_{th j-mb} \leq 15 \text{ }^{\circ}\text{C/W}$)
- U. TRANSISTOR; power, switching ($R_{th j-mb} \leq 15 \text{ }^{\circ}\text{C/W}$)
- X. DIODE; multiplier, e.g. varactor, step recovery
- Y. DIODE; rectifying, booster
- Z. DIODE; voltage reference or regulator (transient suppressor diode, with third letter W)

TYPE DESIGNATION

SERIAL NUMBER

Three figures, running from 100 to 999, for devices primarily intended for consumer equipment. One letter (Z, Y, X, etc.) and two figures, running from 10 to 99, for devices primarily intended for industrial/professional equipment.

This letter has no fixed meaning except W, which is used for transient suppressor diodes.

VERSION LETTER

It indicates a minor variant of the basic type either electrically or mechanically. The letter never has a fixed meaning, except letter R, indicating reverse voltage, e.g. collector to case or anode to stud.

SUFFIX

Sub-classification can be used for devices supplied in a wide range of variants called associated types. Following sub-coding suffixes are in use:

1. VOLTAGE REFERENCE and VOLTAGE REGULATOR DIODES: *ONE LETTER and ONE NUMBER*

The LETTER indicates the nominal tolerance of the Zener (regulation, working or reference) voltage

- A. 1% (according to IEC 63: series E96)
- B. 2% (according to IEC 63: series E48)
- C. 5% (according to IEC 63: series E24)
- D. 10% (according to IEC 63: series E12)
- E. 20% (according to IEC 63: series E6)

The number denotes the typical operating (Zener) voltage related to the nominal current rating for the whole range.

The letter 'V' is used instead of the decimal point.

2. TRANSIENT SUPPRESSOR DIODES: *ONE NUMBER*

The NUMBER indicates the maximum recommended continuous reversed (stand-off) voltage V_R . The letter 'V' is used as above.

3. CONVENTIONAL and CONTROLLED AVALANCHE RECTIFIER DIODES and THYRISTORS: *ONE NUMBER*

The NUMBER indicates the rated maximum repetitive peak reverse voltage (V_{RRM}) or the rated repetitive peak off-state voltage (V_{DRM}), whichever is the lower. Reversed polarity is indicated by letter R, immediately after the number.

4. RADIATION DETECTORS: *ONE NUMBER*, preceded by a hyphen (-)

The NUMBER indicates the depletion layer in μm . The resolution is indicated by a version LETTER.

5. ARRAY OF RADIATION DETECTORS and GENERATORS: *ONE NUMBER*, preceded by a stroke (/).

The NUMBER indicates how many basic devices are assembled into the array.

RATING SYSTEMS

The rating systems described are those recommended by the International Electrotechnical Commission (IEC) in its Publication 134.

DEFINITIONS OF TERMS USED

Electronic device. An electronic tube or valve, transistor or other semiconductor device.

Note

This definition excludes inductors, capacitors, resistors and similar components.

Characteristic. A characteristic is an inherent and measurable property of a device. Such a property may be electrical, mechanical, thermal, hydraulic, electro-magnetic, or nuclear, and can be expressed as a value for stated or recognized conditions. A characteristic may also be a set of related values, usually shown in graphical form.

Bogey electronic device. An electronic device whose characteristics have the published nominal values for the type. A bogey electronic device for any particular application can be obtained by considering only those characteristics which are directly related to the application.

Rating. A value which establishes either a limiting capability or a limiting condition for an electronic device. It is determined for specified values of environment and operation, and may be stated in any suitable terms.

Note

Limiting conditions may be either maxima or minima.

Rating system. The set of principles upon which ratings are established and which determine their interpretation.

Note

The rating system indicates the division of responsibility between the device manufacturer and the circuit designer, with the object of ensuring that the working conditions do not exceed the ratings.

ABSOLUTE MAXIMUM RATING SYSTEM

Absolute maximum ratings are limiting values of operating and environmental conditions applicable to any electronic device of a specified type as defined by its published data, which should not be exceeded under the worst probable conditions.

These values are chosen by the device manufacturer to provide acceptable serviceability of the device, taking no responsibility for equipment variations, environmental variations, and the effects of changes in operating conditions due to variations in the characteristics of the device under consideration and of all other electronic devices in the equipment.

The equipment manufacturer should design so that, initially and throughout life, no absolute maximum value for the intended service is exceeded with any device under the worst probable operating conditions with respect to supply voltage variation, equipment component variation, equipment control adjustment, load variations, signal variation, environmental conditions, and variations in characteristics of the device under consideration and of all other electronic devices in the equipment.

DESIGN MAXIMUM RATING SYSTEM

Design maximum ratings are limiting values of operating and environmental conditions applicable to a bogey electronic device of a specified type as defined by its published data, and should not be exceeded under the worst probable conditions.

These values are chosen by the device manufacturer to provide acceptable serviceability of the device, taking responsibility for the effects of changes in operating conditions due to variations in the characteristics of the electronic device under consideration.

The equipment manufacturer should design so that, initially and throughout life, no design maximum value for the intended service is exceeded with a bogey device under the worst probable operating conditions with respect to supply voltage variation, equipment component variation, variation in characteristics of all other devices in the equipment, equipment control adjustment, load variation, signal variation and environmental conditions.

DESIGN CENTRE RATING SYSTEM

Design centre ratings are limiting values of operating and environmental conditions applicable to a bogey electronic device of a specified type as defined by its published data, and should not be exceeded under normal conditions.

These values are chosen by the device manufacturer to provide acceptable serviceability of the device in average applications, taking responsibility for normal changes in operating conditions due to rated supply voltage variation, equipment component variation, equipment control adjustment, load variation, signal variation, environmental conditions, and variations in the characteristics of all electronic devices.

The equipment manufacturer should design so that, initially, no design centre value for the intended service is exceeded with a bogey electronic device in equipment operating at the stated normal supply voltage.

LETTER SYMBOLS FOR TRANSISTORS AND SIGNAL DIODES

based on IEC Publication 148

LETTER SYMBOLS FOR CURRENTS, VOLTAGES AND POWERS

Basic letters

The basic letters to be used are:

I, i = current
V, v = voltage
P, p = power.

Lower-case basic letters shall be used for the representation of instantaneous values which vary with time.

In all other instances upper-case basic letters shall be used.

Subscripts

A, a	Anode terminal
(AV), (av)	Average value
B, b	Base terminal, for MOS devices: Substrate
(BR)	Breakdown
C, c	Collector terminal
D, d	Drain terminal
E, e	Emitter terminal
F, f	Forward
G, g	Gate terminal
K, k	Cathode terminal
M, m	Peak value
O, o	As third subscript: The terminal not mentioned is open circuited
R, r	As first subscript: Reverse. As second subscript: Repetitive. As third subscript: With a specified resistance between the terminal not mentioned and the reference terminal.
(RMS), (rms)	R. M. S. value
S, s	{ As first or second subscript: Source terminal (for FETS only) As second subscript: Non-repetitive (not for FETS) As third subscript: Short circuit between the terminal not mentioned and the reference terminal
X, x	Specified circuit
Z, z	Replaces R to indicate the actual working voltage, current or power of voltage reference and voltage regulator diodes.

Note: No additional subscript is used for d. c. values.

LETTER SYMBOLS

Upper-case subscripts shall be used for the indication of:

- a) continuous (d. c.) values (without signal)
Example I_B
- b) instantaneous total values
Example i_B
- c) average total values
Example $I_{B(AV)}$
- d) peak total values
Example I_{BM}
- e) root-mean-square total values
Example $I_{B(RMS)}$

Lower-case subscripts shall be used for the indication of values applying to the varying component alone:

- a) instantaneous values
Example i_b
- b) root-mean-square values
Example $I_{b(rms)}$
- c) peak values
Example I_{bm}
- d) average values
Example $I_{b(av)}$

Note: If more than one subscript is used, subscript for which both styles exist shall either be all upper-case or all lower-case.

Additional rules for subscripts

Subscripts for currents

Transistors: If it is necessary to indicate the terminal carrying the current, this should be done by the first subscript (conventional current flow from the external circuit into the terminal is positive).

Examples: I_B , i_B , i_b , I_{bm}

Diodes: To indicate a forward current (conventional current flow into the anode terminal) the subscript F or f should be used; for a reverse current (conventional current flow out of the anode terminal) the subscript R or r should be used.

Examples: I_F , I_R , i_F , i_r , $I_{i(rms)}$

Subscripts for voltages

Transistors: If it is necessary to indicate the points between which a voltage is measured, this should be done by the first two subscripts. The first subscript indicates the terminal at which the voltage is measured and the second the reference terminal or the circuit node. Where there is no possibility of confusion, the second subscript may be omitted.

Examples: V_{BE} , v_{BE} , v_{be} , V_{bem}

Diodes: To indicate a forward voltage (anode positive with respect to cathode), the subscript F or f should be used; for a reverse voltage (anode negative with respect to cathode) the subscript R or r should be used.

Examples: V_F , V_R , v_F , V_{rm}

Subscripts for supply voltages or supply currents

Supply voltages or supply currents shall be indicated by repeating the appropriate terminal subscript.

Examples: V_{CC} , I_{EE}

Note: If it is necessary to indicate a reference terminal, this should be done by a third subscript

Example: V_{CCE}

Subscripts for devices having more than one terminal of the same kind

If a device has more than one terminal of the same kind, the subscript is formed by the appropriate letter for the terminal followed by a number; in the case of multiple subscripts, hyphens may be necessary to avoid misunderstanding.

Examples: I_{B2} = continuous (d. c.) current flowing into the second base terminal

V_{B2-E} = continuous (d. c.) voltage between the terminals of second base and emitter

Subscripts for multiple devices

For multiple unit devices, the subscripts are modified by a number preceding the letter subscript; in the case of multiple subscripts, hyphens may be necessary to avoid misunderstanding.

Examples: I_{2C} = continuous (d. c.) current flowing into the collector terminal of the second unit

V_{1C-2C} = continuous (d. c.) voltage between the collector terminals of the first and the second unit.

Application of the rules

The figure below represents a transistor collector current as a function of time. It consists of a continuous (d. c.) current and a varying component.

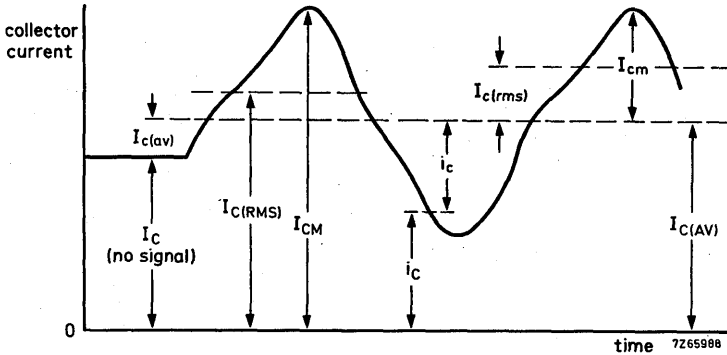

LETTER SYMBOLS FOR ELECTRICAL PARAMETERS

Definition

For the purpose of this Publication, the term "electrical parameter" applies to four-pole matrix parameters, elements of electrical equivalent circuits, electrical impedances and admittances, inductances and capacitances.

Basic letters

The following is a list of the most important basic letters used for electrical parameters of semiconductor devices.

- B, b = susceptance; imaginary part of an admittance
- C = capacitance
- G, g = conductance; real part of an admittance
- H, h = hybrid parameter
- L = inductance
- R, r = resistance; real part of an impedance
- X, x = reactance; imaginary part of an impedance
- Y, y = admittance;
- Z, z = impedance;

Upper-case letters shall be used for the representation of:

- a) electrical parameters of external circuits and of circuits in which the device forms only a part;
- b) all inductances and capacitances.

Lower-case letters shall be used for the representation of electrical parameters inherent in the device (with the exception of inductances and capacitances).

Subscripts

General subscripts

The following is a list of the most important general subscripts used for electrical parameters of semiconductor devices:

- F, f = forward; forward transfer
- I, i (or 1) = input
- L, l = load
- O, o (or 2) = output
- R, r = reverse; reverse transfer
- S, s = source

Examples: Z_S, h_f, h_F

The upper-case variant of a subscript shall be used for the designation of static (d.c.) values.

- Examples : h_{FE} = static value of forward current transfer ratio in common-emitter configuration (d.c. current gain)
- R_E = d.c. value of the external emitter resistance.

Note: The static value is the slope of the line from the origin to the operating point on the appropriate characteristic curve, i.e. the quotient of the appropriate electrical quantities at the operating point.

The lower-case variant of a subscript shall be used for the designation of small-signal values.

- Examples: h_{fe} = small-signal value of the short-circuit forward current transfer ratio in common-emitter configuration
- $Z_e = R_e + jX_e$ = small-signal value of the external impedance

Note: If more than one subscript is used, subscripts for which both styles exist shall either be all upper-case or all lower-case

Examples: h_{FE}, y_{RE}, h_{fe}

Subscripts for four-pole matrix parameters

The first letter subscript (or double numeric subscript) indicates input, output, forward transfer or reverse transfer

Examples: h_i (or h_{11})
 h_o (or h_{22})
 h_f (or h_{21})
 h_r (or h_{12})

A further subscript is used for the identification of the circuit configuration. When no confusion is possible, this further subscript may be omitted.

Examples: h_{fe} (or h_{21e}), h_{FE} (or h_{21E})

Distinction between real and imaginary parts

If it is necessary to distinguish between real and imaginary parts of electrical parameters, no additional subscripts should be used. If basic symbols for the real and imaginary parts exist, these may be used.

Examples: $Z_i = R_i + jX_i$
 $y_{fe} = g_{fe} + jb_{fe}$

If such symbols do not exist or if they are not suitable, the following notation shall be used:

Examples: $\text{Re}(h_{ib})$ etc. for the real part of h_{ib}
 $\text{Im}(h_{ib})$ etc. for the imaginary part of h_{ib}

DEFINITIONS APPLYING TO PHOTSENSITIVE DEVICES

to IEC 306

DEFINITIONS AND UNITS OF RADIATION AND LIGHT QUANTITIES

Radiant flux: radiant power

Power emitted, transferred or received in the form of radiation.

Symbols: ϕ_e , ϕ , P $\phi_e = \frac{dQ_e}{dt}$; unit: watt, W.

Radiant intensity

The radiant intensity of a source in a given direction is the quotient of (1) the radiant flux leaving the source propagated in an element of solid angle containing the given direction, by (2) the element of solid angle.

Symbols: I_e , I $I_e = \frac{d\phi_e}{d\Omega}$; unit: watt per steradian, W/sr.

Irradiance

The irradiance at a point of a surface is the quotient of (1) the radiant flux incident on an element of the surface containing the point, by (2) the area of that element.

Symbols: E_e , E $E_e = \frac{d\phi_e}{dA}$; unit: watt per square metre, W/m².

Light

Radiation capable of stimulating the organ of vision. ¹⁾

Luminous flux

Quantity derived from radiant flux by evaluating the radiation according to its action upon a selective receptor, the spectral sensitivity of which is defined by the standard spectral luminous efficiency.

Symbols: ϕ_v , ϕ ; unit: lumen, lm.

Lumen

SI unit of luminous flux: luminous flux emitted within unit solid angle (one steradian) by a point source having a uniform intensity of 1 candela. (An isotropic source of intensity 1 candela emits 4π lumens of luminous flux.)

Symbol: lm.

¹⁾ For convenience, exceptions from this definition are made in the data sheets, e. g. dark and light currents (excluding and including respectively near infrared radiation) of a phototransistor, light rise time of a near-infrared light emitting diode.

GENERAL

Luminous intensity

The luminous intensity of a source in a given direction is the quotient of (1) the luminous flux leaving the source propagated in an element of solid angle containing the given direction, by (2) the element of solid angle.

Symbols: I_v , I $I_v = \frac{d\phi_v}{d\Omega}$; unit: candela, cd.

Candela

SI unit of luminous intensity: Luminous intensity, in the perpendicular direction, of a surface of 1/600 000 square metre of a black body at the temperature of freezing platinum under a pressure of 101 235 newtons per square metre.

Symbols: cd; 1 cd = 1 lm/sr.

Illuminance

At a point of a surface, the quotient of (1) the luminous flux incident on an element of the surface containing the point, by (2) the area of that element.

Symbols: E_v , E $E_v = \frac{d\phi_v}{dA}$; unit: lux, lx.

Lux; lumen per square metre

SI unit of illuminance: illuminance produced by a luminous flux of 1 lumen uniformly distributed over a surface of area 1 square metre.

Symbol: lx ; 1 lx = 1 lm/m².

Distribution temperature

Temperature of the full radiator for which the ordinates of the spectral distribution curve of its radiance are proportional, in the visible region, to those of the distribution curve of the radiation considered.

The unit of measurement is degree Kelvin (K).

Colour temperature

For the purpose of this Recommendation, colour temperature is the distribution temperature of the radiation source.

The unit of measurement is degree Kelvin.

DEFINITIONS OF ELECTRICAL QUANTITIES

Photocurrent

The change in output current from the photocathode caused by incident radiation.

Frequency response characteristic

Relation, usually shown by a graph, between the radiant (or luminous) dynamic sensitivity and the modulation frequency of the incident radiation.

Dark current

The current flowing in a photoelectric device in the absence of irradiation.

Equivalent dark-current irradiation

The incident radiation required to give a d.c. signal output current equal to the dark current.

Equivalent noise irradiation

The value of incident radiation which, when modulated in a stated manner, produces a signal output power equal to the noise power, both in a stated bandwidth.

Quantum efficiency

The ratio of (1) the number of emitted photoelectrons to (2) the number of incident photons.

Quantum efficiency (Q. E.) at a given wavelength of incident radiation may be computed from:

$$\text{Q. E.} = \frac{\text{const.} \times s_k}{\lambda}$$

where:

s_k	= spectral sensitivity (amperes per watt) at wavelength λ
λ	= wavelength of incident radiation (nanometres)
const. = hc_0/e	= 1.24×10^3 W.nm/A
h	= Planck constant
c_0	= speed of propagation of electromagnetic waves in vacuo
e	= elementary charge

Saturation voltage

The lowest operating voltage which causes no change, or only a slight change, of the photocurrent when this voltage is increased under conditions of given constant radiation.

Saturation current

The output current of a photosensitive device which is not changed, or only insignificantly changed, by an increase of either:

- the irradiance under constant operating conditions; or
- the operating voltage under constant irradiance.

Note. — The context should make clear which definition is applicable.

DEFINITIONS OF SENSITIVITY

These definitions apply more directly to photocathode sensitivity. For devices in which it is necessary to define the anode (over-all) sensitivity, signal output current should be considered instead of photocurrent.

Radiant sensitivity

- a) The quotient of (1) the photocurrent of the device by (2) the incident radiant power, expressed in amperes per watt.
- b) The quotient of (1) the photocurrent of the device by (2) the incident irradiance, expressed in amperes per watt/m².

Absolute spectral sensitivity

The radiant sensitivity for monochromatic radiation of a stated wavelength.

Relative spectral sensitivity

The ratio of (1) the radiant sensitivity at any considered wavelength to (2) the radiant sensitivity at a certain wavelength taken as reference, usually the wavelength of maximum response.

Note. — For non-linear detectors, it is necessary to refer to constant photocurrent at all wavelengths.

Luminous sensitivity

- a) The quotient of (1) the photocurrent of the device by (2) the incident luminous flux, expressed in amperes per lumen.
- b) The quotient of (1) the photocurrent of the device by (2) the incident illuminance, expressed in amperes per lux.

Dynamic sensitivity

Under stated conditions of operation, the quotient of (1) the variation of the photocurrent of the device by (2) the initiating small variation of the incident radiant power (or luminous)

Note. — Distinction is made between "luminous dynamic sensitivity" and "radiant sensitivity."

Spectral sensitivity characteristic

The relation, usually shown by a graph, between wavelength and absolute or relative spectral sensitivity.

Absolute spectral sensitivity characteristic

The relation, usually shown by a graph, between wavelength and absolute spectral sensitivity.

Relative spectral sensitivity characteristic

The relation between wavelength and relative spectral sensitivity.

Quantum efficiency characteristic

The relation, usually shown by a graph, between wavelength and quantum efficiency.

DEFINITIONS OF TIME QUANTITIES**Rise time**

The time required for the photocurrent to rise from a stated low percentage to a stated higher percentage of the maximum value when a steady state of radiation is instantaneously applied.

It is usual to consider the 10 % and 90 % levels.

Fall time

The time required for the photocurrent to fall from a stated high percentage to a stated lower percentage of the maximum value when the steady state of radiation is instantaneously removed.

It is usual to consider the 90 % and 10 % levels.

SAFETY

The most modern high technology materials have been used in these components to ensure the highest performance for the user. Some of them are toxic to man but the quantity used in a single device is so small that the risk of toxic effects are negligible even in extreme circumstances.





PHOTOSENSITIVE DIODES AND TRANSISTORS





SILICON PHOTOTRANSISTOR

N-P-N silicon phototransistor in epoxy resin encapsulation intended to be used in combination with the infrared LED CQY58. The base is inaccessible.

QUICK REFERENCE DATA

Collector-emitter voltage	V_{CEO}	max.	30	V
Collector current (d. c.)	I_C	max.	25	mA
Total power dissipation up to $T_{amb} = 25\text{ }^\circ\text{C}$	P_{tot}	max.	50	mW
Collector dark current $V_{CE} = 20\text{ V}; E = 0$	$I_{CEO(D)}$	<	100	nA
Collector light current $V_{CE} = 5\text{ V}; E_e = 5\text{ mW/cm}^2; \lambda_{pk} = 875\text{ nm}$	$I_{CEO(L)}$	>	6	mA
Wavelength at peak response	λ_{pk}	typ.	800	nm

MECHANICAL DATA

Dimensions in mm

SOD-53D

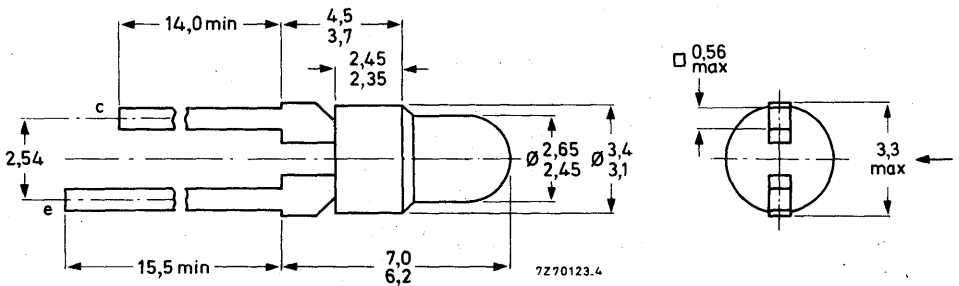

BPW22

RATINGS Limiting values in accordance with the Absolute Maximum System (IEC 134)

Voltage

Collector-emitter voltage	V_{CEO}	max.	30 V
Emitter-collector voltage	V_{ECO}	max.	5 V

Current

Collector current (d.c.)	I_C	max.	25 mA
Collector current (peak value)	I_{CM}	max.	50 mA

Power dissipation

Total power dissipation up to $T_{amb} = 25\text{ }^\circ\text{C}$	P_{tot}	max.	50 mW
--	-----------	------	-------

Temperature

Storage temperature	T_{stg}	-55 to +100	$^\circ\text{C}$
Junction temperature	T_j	max.	100 $^\circ\text{C}$
Lead soldering temperature > 3 mm from the body; $t_{sld} < 7\text{ s}$	T_{sld}	max.	230 $^\circ\text{C}$

THERMAL RESISTANCE

From junction to ambient,
device mounted on printed-circuit board $R_{th\ j-a} = 1,5\text{ }^\circ\text{C/mW}$

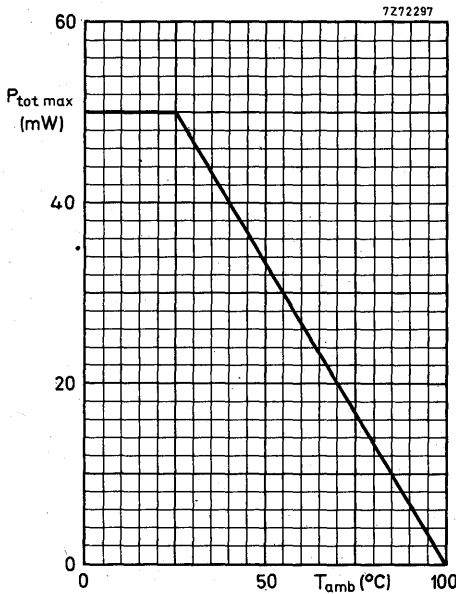

CHARACTERISTICS

$T_j = 25\text{ }^\circ\text{C}$ unless otherwise specified

Collector dark current

$V_{CE} = 20\text{ V}; E = 0$

$I_{CEO(D)} < 100\text{ nA}$

Collector light current

$V_{CE} = 5\text{ V}; E_e = 5\text{ mW/cm}^2; \lambda_{pk} = 875\text{ nm}^1)$

$I_{CEO(L)} > 6\text{ mA}$
typ. 15 mA

Collector-emitter saturation voltage

$I_C = 4\text{ mA}; E_e = 5\text{ mW/cm}^2; \lambda_{pk} = 875\text{ nm}^1)$

$V_{CEsat} < 0,4\text{ V}$

Wavelength at peak response

λ_{pk} typ. 800 nm

Bandwidth at half height

$B_{50\%}$ typ. 400 nm

Beamwidth between half sensitivity directions

$\alpha_{50\%}$ typ. 10°

Switching times (circuit below)

$I_{Con} = 1\text{ mA}; V_{CC} = 20\text{ V}; R_E = 1\text{ k}\Omega; T_{amb} = 25\text{ }^\circ\text{C}$

Rise time

t_r typ. 7,5 μs

Fall time

t_f typ. 7,5 μs

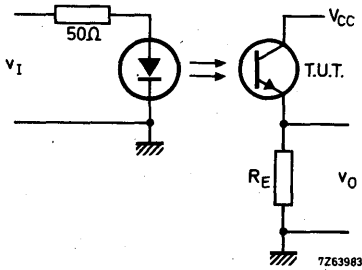

LED = CQY58

T. U. T. = BPW22

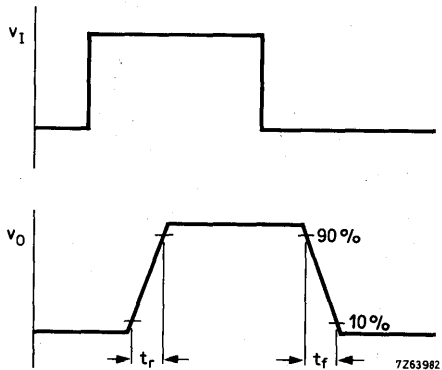

¹⁾ Measured with pulsed GaAs light source.

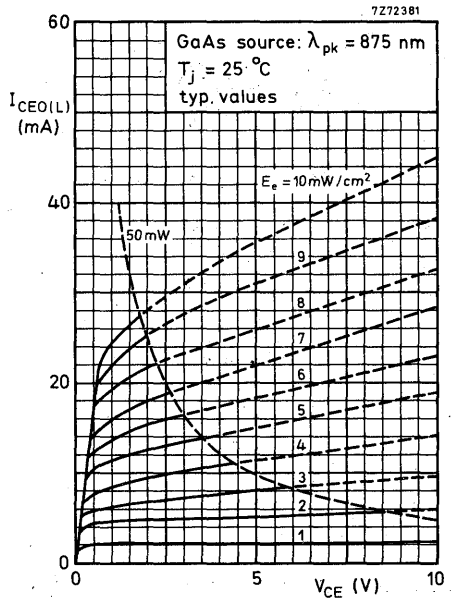
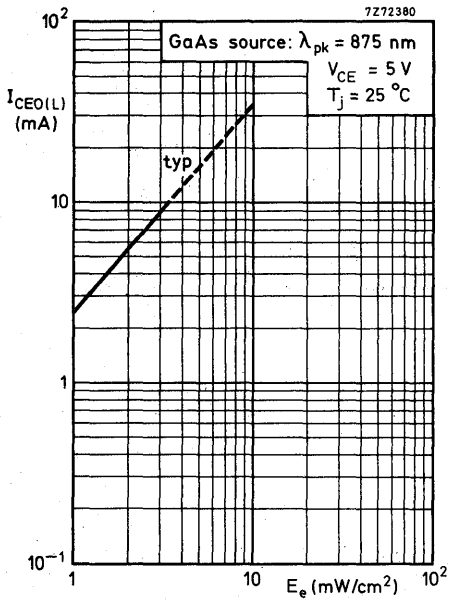
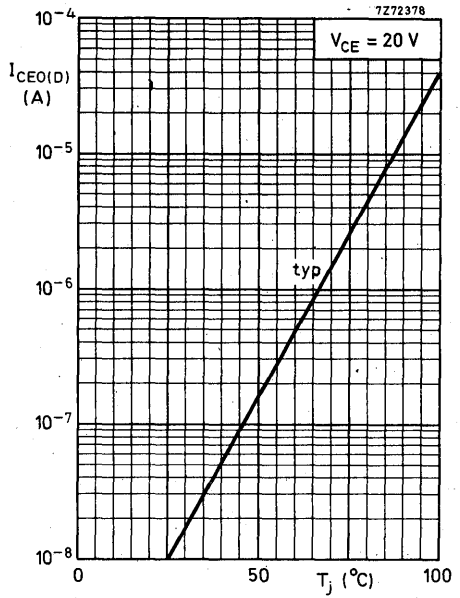
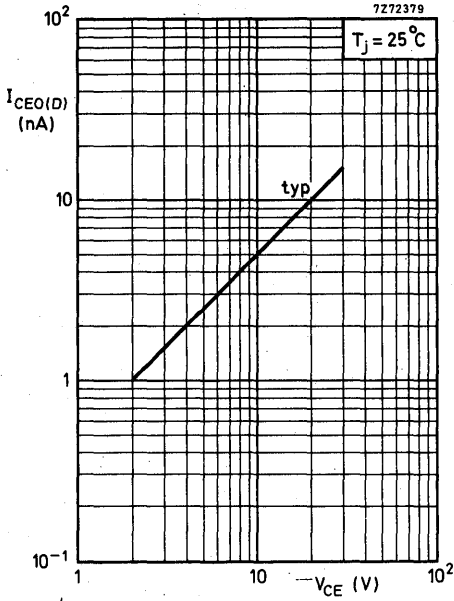

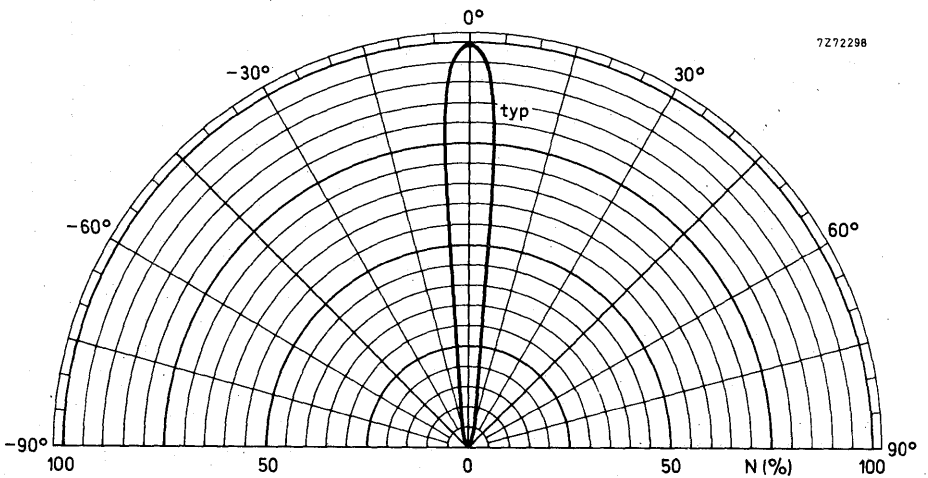
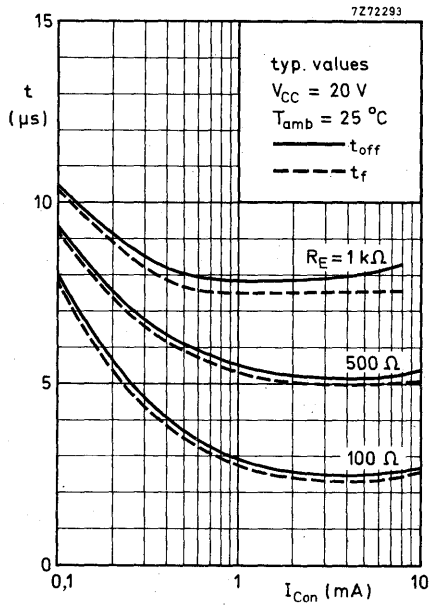
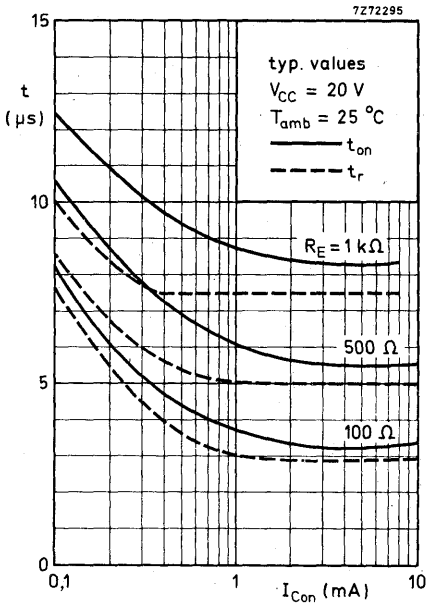

BPW22

7272296

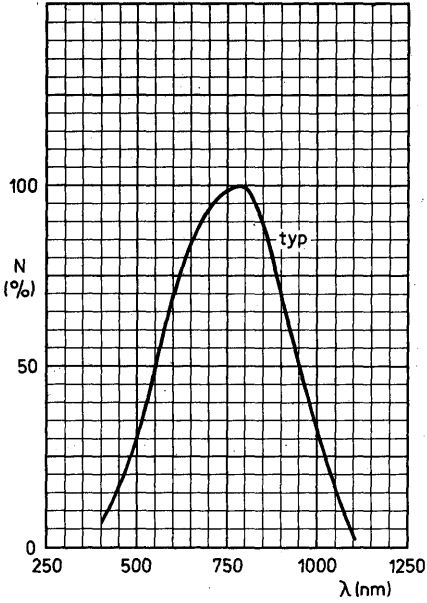

7273051

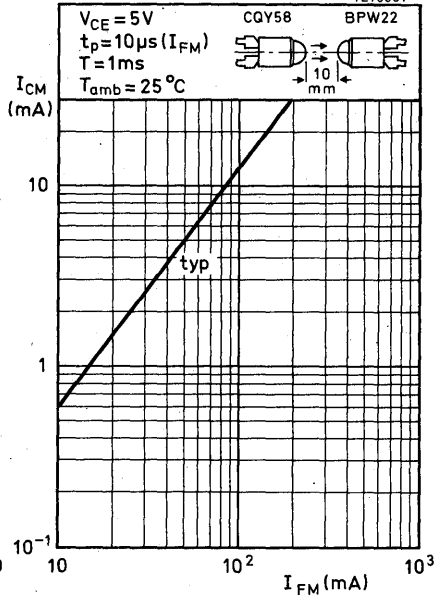

7273048

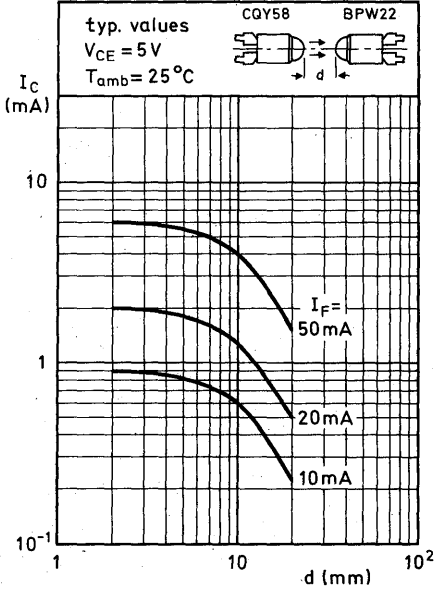

7273049

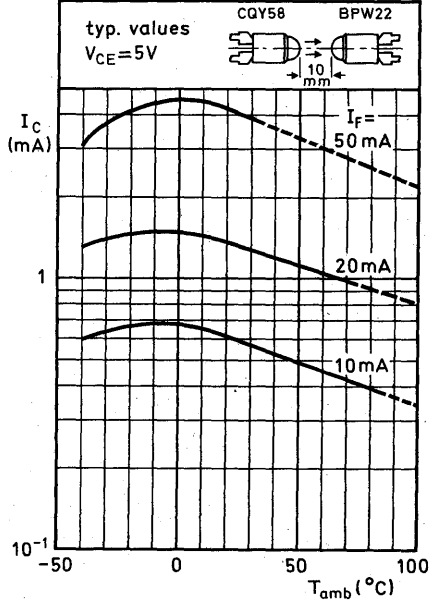

SILICON PHOTODIODE

Silicon planar photodiode for infrared remote control, infrared sound transmission, and general purposes. The rectangular shape of its envelope, the square sensitive area of 2,75 mm x 2,75 mm, and the pin distance of 5,08 mm, render it suitable for use on a printed-circuit board.

QUICK REFERENCE DATA

Continuous reverse voltage	V_R	max.	32 V
Total power dissipation up to $T_{amb} = 25\text{ }^\circ\text{C}$	P_{tot}	max.	150 mW
Junction temperature	T_j	max.	90 $^\circ\text{C}$
Dark reverse current	$I_{R(D)}$	<	30 nA
Light sensitivity	N	>	50 nA/lx
Wavelength at peak response	λ_{pk}	typ.	850 nm
$V_R = 10\text{ V}$			
$V_R = 5\text{ V}; T_C = 2856\text{ K}$			
$V_R = 5\text{ V}$			

MECHANICAL DATA

Dimensions in mm

Fig. 1 SOD-62A.

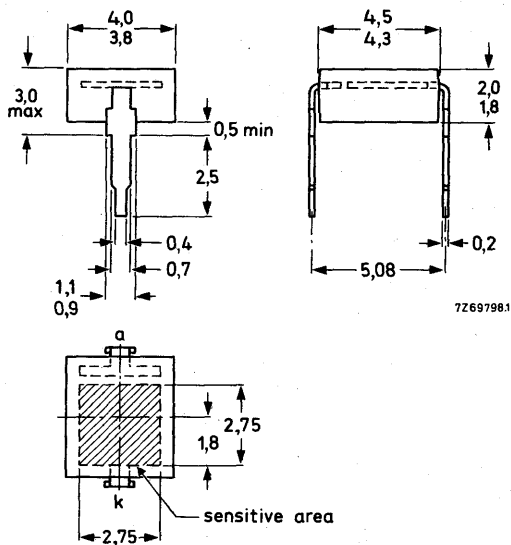

RATINGS

Limiting values in accordance with the Absolute Maximum System (IEC 134)

Continuous reverse voltage	V_R	max.	32 V
Total power dissipation up to $T_{amb} = 25\text{ }^\circ\text{C}$	P_{tot}	max.	150 mW
Storage temperature	T_{stg}		-30 to +90 $^\circ\text{C}$
Junction temperature	T_j	max.	90 $^\circ\text{C}$

THERMAL RESISTANCE

From junction to ambient	$R_{th\ j-a}$	=	435 $^\circ\text{C/W}$
--------------------------	---------------	---	------------------------

CHARACTERISTICS

$T_{amb} = 25\text{ }^\circ\text{C}$ unless otherwise specified

Dark reverse current

$V_R = 10\text{ V}; E_V = 0$

$I_{R(D)}$	typ.	2 nA
	<	30 nA

Light reverse current

$V_R = 0; E_V = 100\text{ lx}; T_c = 2856\text{ K}^*$

$I_{R(L)}$	typ.	6,5 μA
------------	------	-------------------

Photovoltaic mode at $T_c = 2856\text{ K}^*$

Open-circuit voltage (light forward voltage)

$I = 0; E_V = 100\text{ lx}$

$I = 0; E_V = 1000\text{ lx}$

$V_{F(L)}$	typ.	240 mV
$V_{F(L)}$	typ.	350 mV

Temperature coefficient of open-circuit voltage

$\frac{\Delta V_{F(L)}}{\Delta T_{amb}}$	typ.	-2,6 mV/ $^\circ\text{C}$
--	------	---------------------------

Temperature coefficient of short-circuit current

$\frac{\Delta I_{R(L)}}{\Delta T_{amb}}$	typ.	0,2 %/ $^\circ\text{C}$
--	------	-------------------------

Light sensitivity with external voltage

$V_R = 5\text{ V}; E_V = 1000\text{ lx}; T_c = 2856\text{ K}^*$

N	>	50 nA/lx
	typ.	70 nA/lx

Wavelength at peak response

$V_R = 5\text{ V}$

λ_{pk}	typ.	850 nm
----------------	------	--------

Diode capacitance

$V_R = 3\text{ V}$

C_d	typ.	25 pF
	<	40 pF

$V_R = 0$

C_d	typ.	72 pF
-------	------	-------

Light switching times (see Figs 2 and 3)

Rise time and fall time

$V_{KK} = 5\text{ V}; R_A = 1\text{ k}\Omega^{**}$

$V_{KK} = 0; R_A = 1\text{ k}\Omega^{**}$

t_r, t_f	typ.	50 ns
t_r, t_f	typ.	125 ns

* Unfiltered tungsten filament lamp source.

** V_{KK} is cathode supply voltage; R_A is anode series resistance.

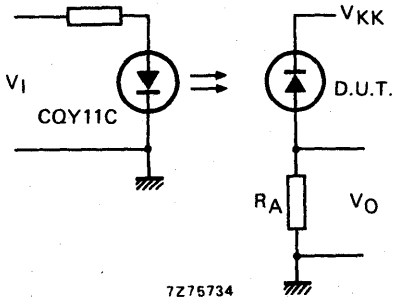

Fig. 2. Switching circuit.

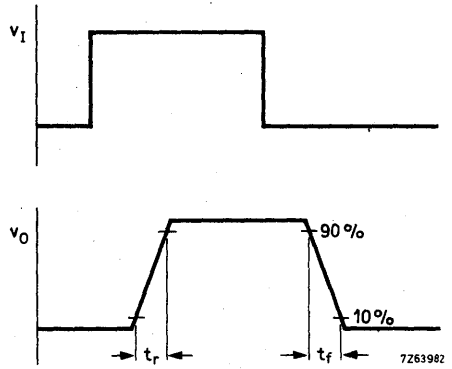

Fig. 3. Input and output switching waveforms.

Fig. 2 $E = 0$; $T_{amb} = 25^\circ C$.

Fig. 3 Typical values; $E = 0$.

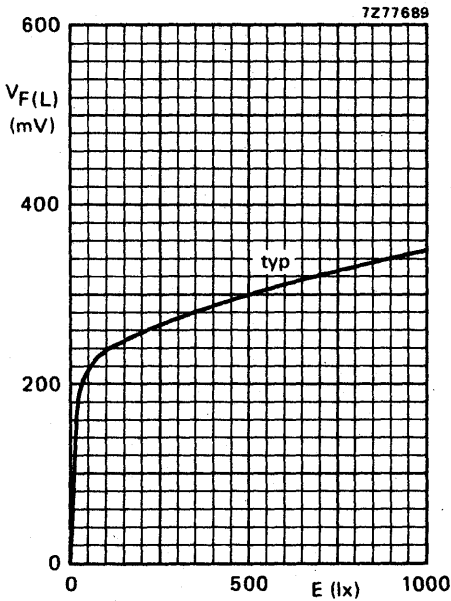

Fig. 4 $I = 0$; $T_{amb} = 25^\circ C$.

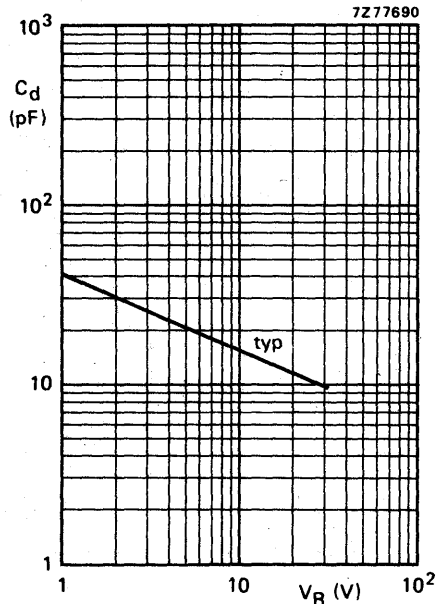

Fig. 5 $T_{amb} = 25^\circ C$.

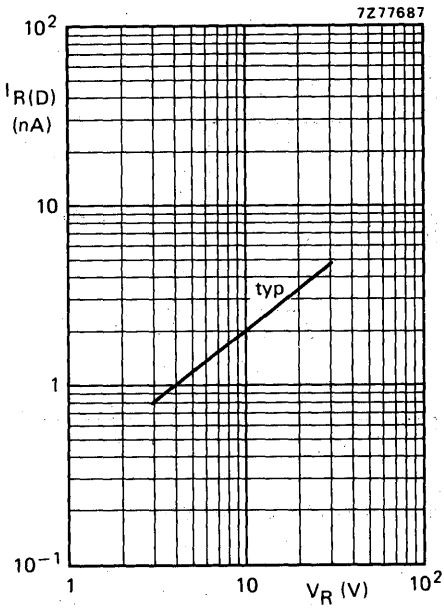

Fig. 6 $E = 0$; $T_{amb} = 25^\circ C$.

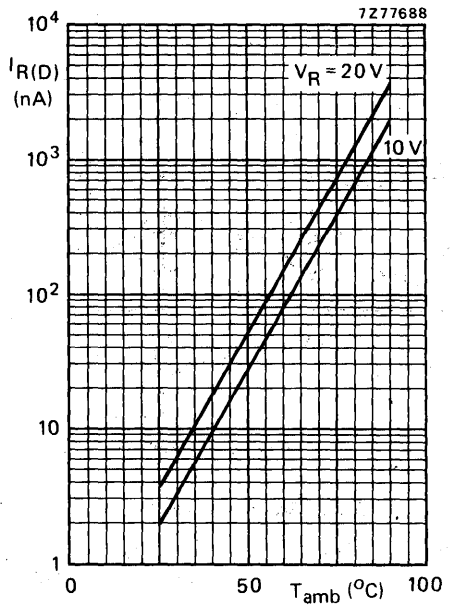

Fig. 7 Typical values; $E = 0$.

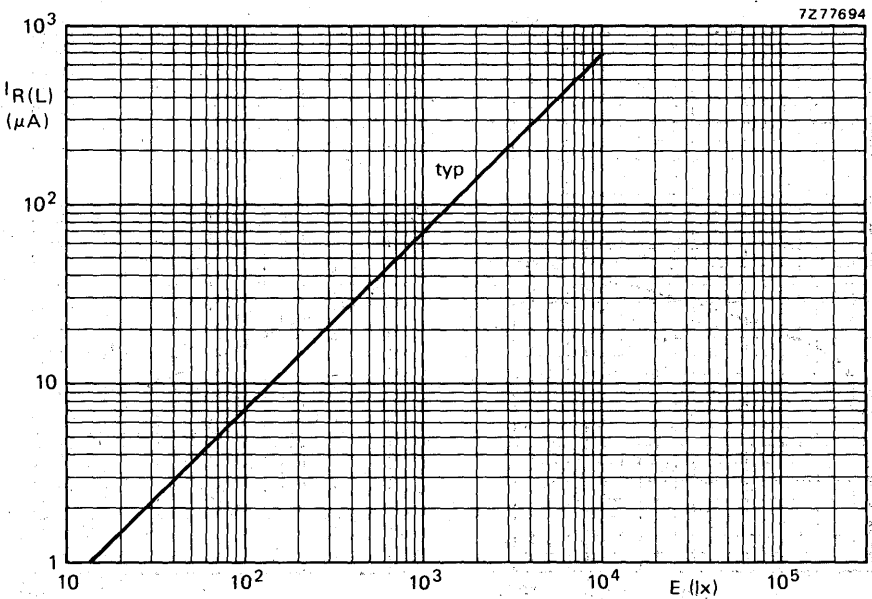

Fig. 8 $V_R = 5 V$; $T_{amb} = 25^\circ C$.

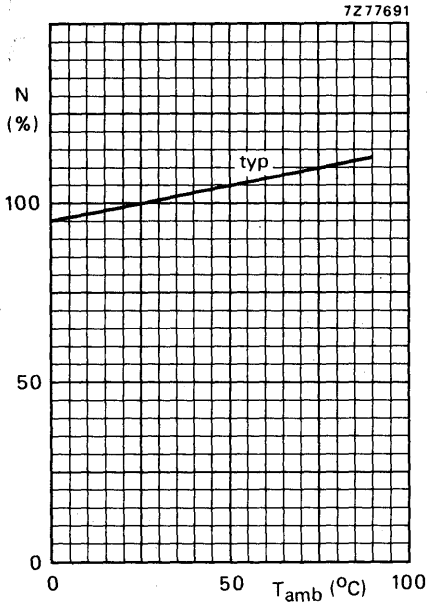

Fig.9 $V_R = 5 V$; $E_V = 1000 lx$.

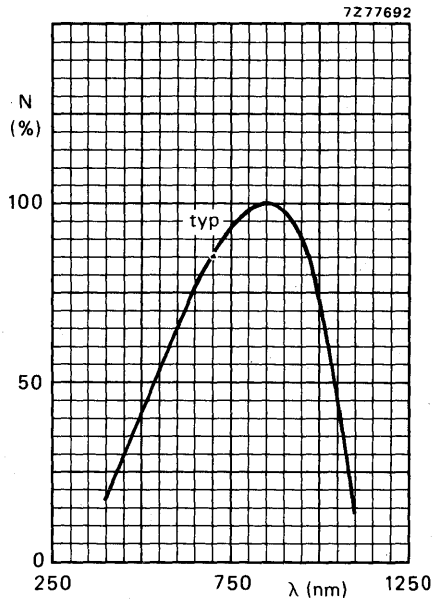

Fig.10.

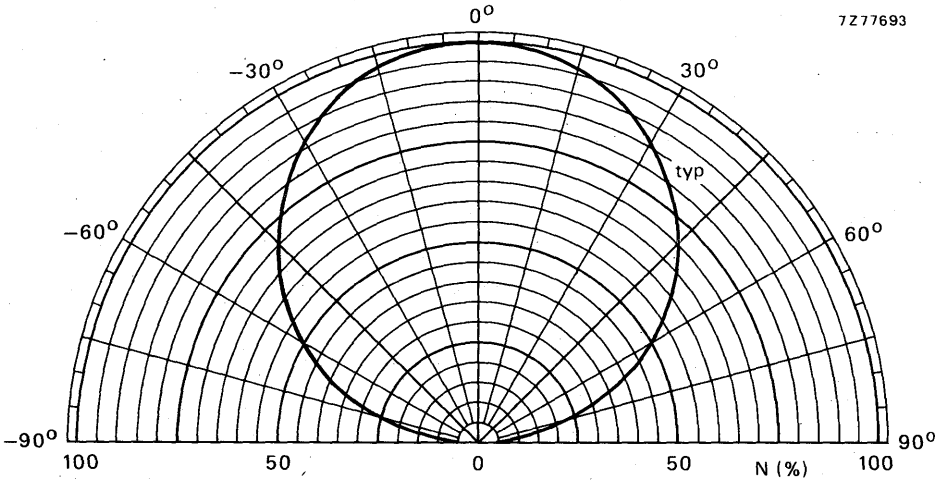

Fig.11.



SILICON PLANAR EPITAXIAL PHOTOTRANSISTORS

General purpose n-p-n silicon phototransistors in TO-18.
The BPX25 has a lens, the BPX29 has a plane window.

QUICK REFERENCE DATA							
Collector-emitter voltage (open base)	V_{CEO}	max.	32 V				
Collector current (peak value)	I_{CM}	max.	200 mA				
Junction temperature	T_j	max.	150 °C				
Collector dark current $I_B = 0; V_{CE} = 24 V$	$I_{CEO(D)}$	<	500 nA				
Collector light current $I_B = 0; V_{CE} = 6 V; \text{at } 1000 \text{ lx}$	$I_{CEO(L)}$	typ.	<table border="1"> <thead> <tr> <th>BPX25</th> <th>BPX29</th> </tr> </thead> <tbody> <tr> <td>13</td> <td>0,8</td> </tr> </tbody> </table> mA	BPX25	BPX29	13	0,8
BPX25	BPX29						
13	0,8						
Wavelength at peak response	λ_{pk}	typ.	800 nm				

MECHANICAL DATA

Dimensions in mm

BPX25

TO-18, except for lens
Collector connected to case

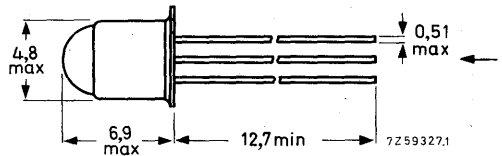
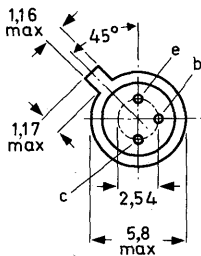

BPX29

TO-18, except for window
Collector connected to case

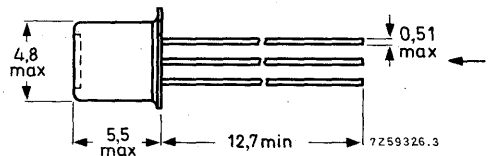
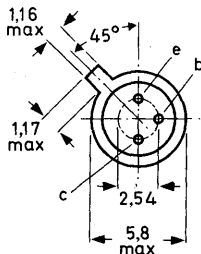

RATINGS Limiting values in accordance with the Absolute Maximum System (IEC 134)

Voltages

Collector-base voltage (open emitter)	V_{CBO}	max.	32	V
Collector-emitter voltage (open base)	V_{CEO}	max.	32	V
Emitter-base voltage (open collector)	V_{EBO}	max.	5	V

Current

Collector current (d. c.)	I_C	max.	100	mA
Collector current (peak value)	I_{CM}	max.	200	mA

Power dissipation

Total power dissipation up to $T_{amb} = 25^\circ\text{C}$	P_{tot}	max.	300	mW
--	-----------	------	-----	----

Temperatures

Storage temperature	T_{stg}	-65 to +150	$^\circ\text{C}$
Junction temperature	T_j	max.	150 $^\circ\text{C}$

THERMAL RESISTANCE

From junction to ambient in free air	$R_{th\ j-a}$	=	0,4	$^\circ\text{C}/\text{mW}$
From junction to case	$R_{th\ j-c}$	=	0,15	$^\circ\text{C}/\text{mW}$

CHARACTERISTICS

$T_{amb} = 25^\circ\text{C}$ unless otherwise specified

Collector dark current

$I_B = 0; V_{CE} = 24\text{ V}$

$I_{CEO(D)}$	typ.	100	nA
	<	500	nA

$I_B = 0; V_{CE} = 24\text{ V}; T_{amb} = 100^\circ\text{C}$

$I_{CEO(D)}$	typ.	15	μA
	<	100	μA

Collector light current

$I_B = 0; V_{CE} = 6\text{ V};$ tungsten filament lamp
source with $T_c = 2700\text{ K};$
 $E_v = 1000\text{ lx } (7,7\text{ mW}/\text{cm}^2)$

		BPX25	BPX29
$I_{CEO(L)}$	>	5	0,25 mA
	typ.	13	0,8 mA

D. C. current gain

$I_C = 2\text{ mA}; V_{CE} = 6\text{ V}$

h_{FE}	typ.	500	500
----------	------	-----	-----

Cut-off frequency

Source : modulated GaAs; $0,4\text{ mW}/\text{cm}^2$
Load : optimum (50 Ω); $V_{CE} = 24\text{ V}$

f_{co}	typ.	200	150 kHz
----------	------	-----	---------

CHARACTERISTICS (continued)

		BPX25	BPX29
<u>Switching times</u> ¹⁾			
Delay time	t_d	typ. 1,0 < 3,0	2,5 μs 5,0 μs
Rise time	t_r	typ. 1,5 < 3,0	2,5 μs 5,0 μs
Storage time	t_s	typ. 0,2 < 0,4	0,2 μs 0,4 μs
Fall time	t_f	typ. 1,5 < 4,0	3,5 μs 8,0 μs
<u>Wavelength at peak response</u>	λ_{pk}	typ. 800	800 nm

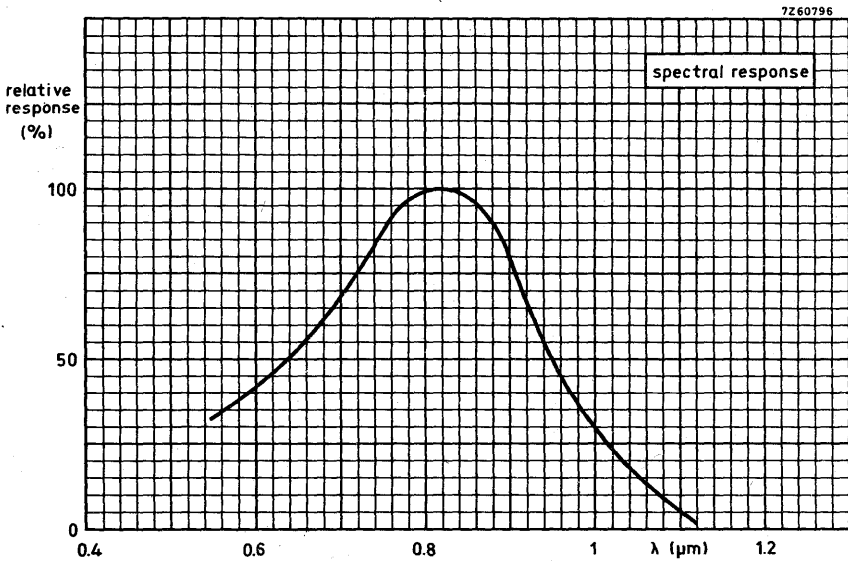

¹⁾ Source: modulated GaAs: 0,4 mW/cm²

Load: optimum (50 Ω)

V_{CE} = 24 V

Improved switching times can be obtained by a quiescent bias current.

I. e. I_B = 2 μA : $t_d < 0,2 \mu s$.

BPX25
BPX29

7267709

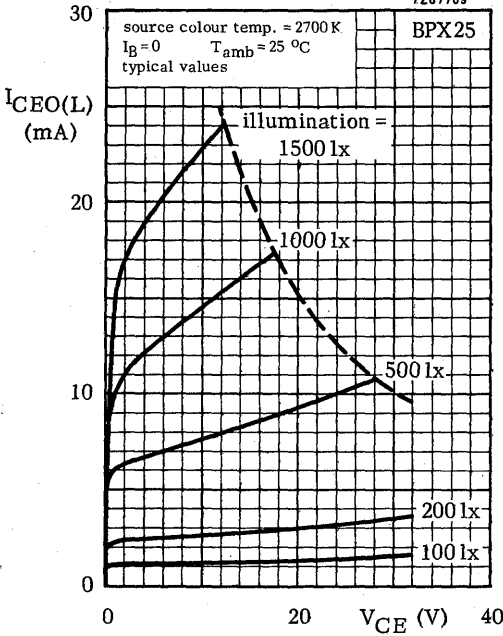

7267859

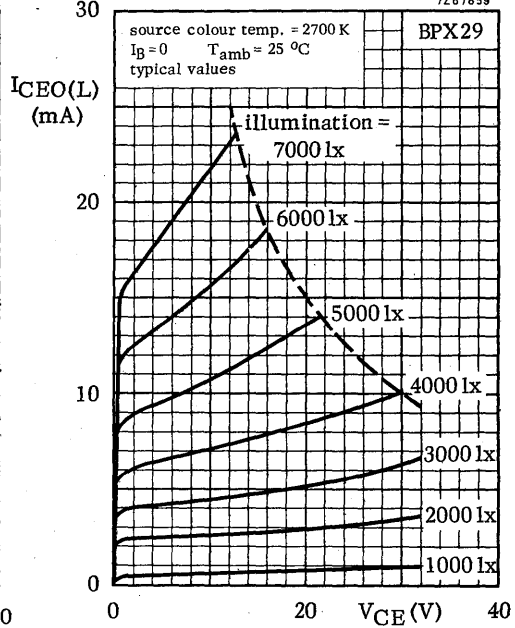

7267711

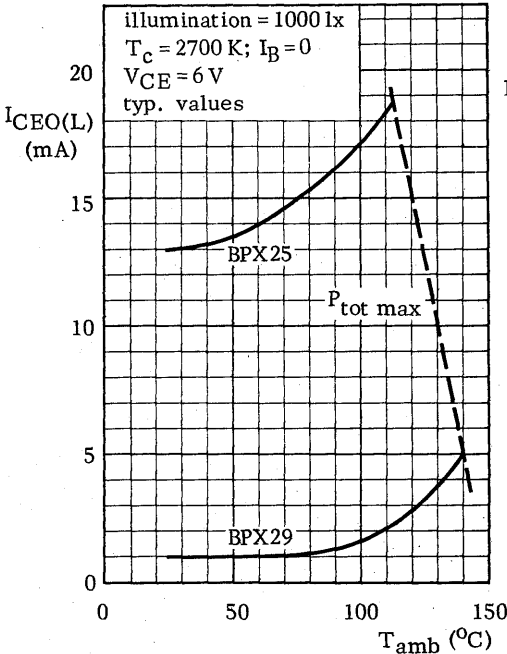

7267710

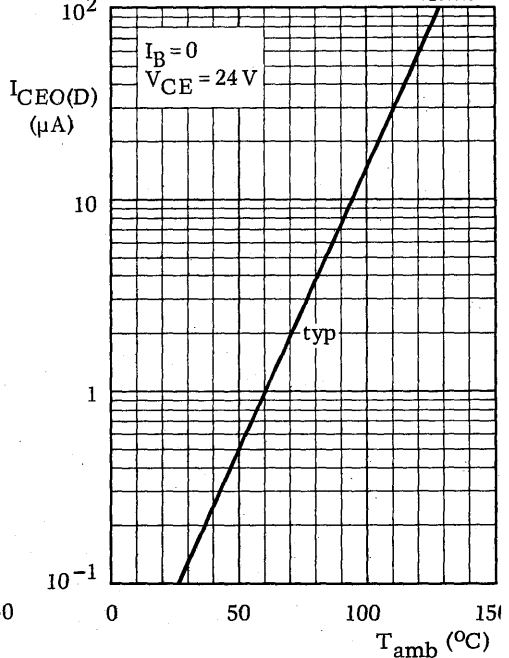

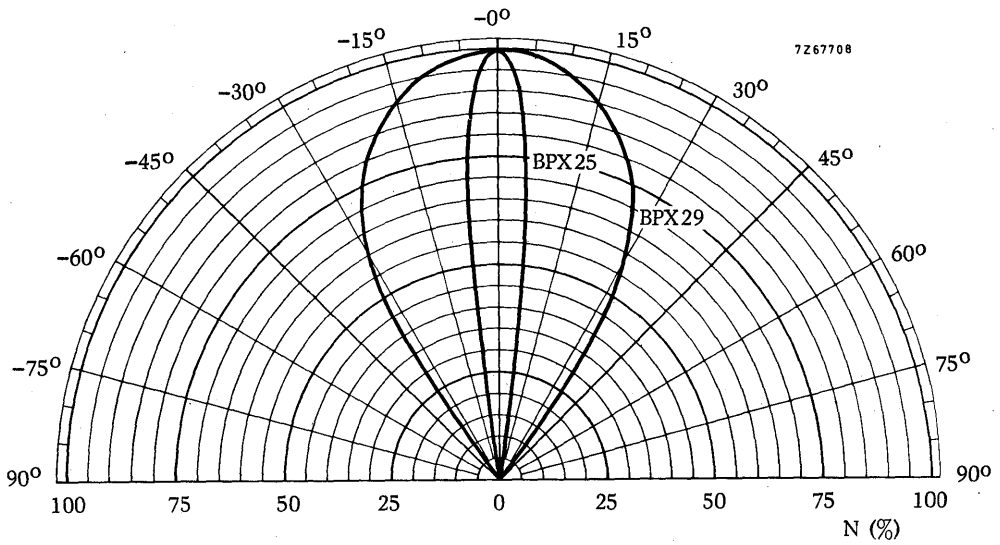



SILICON PLANAR PHOTODIODE

Unencapsulated photodiode for general purpose applications.

QUICK REFERENCE DATA

Reverse voltage	V_R	max.	18	V
Luminous sensitivity $V_R = 15$ V; $E = 1000$ lx	N	typ.	14	nA/lx
Dark reverse current at $V_R = 15$ V	I_d	<	0,5	μ A
Wavelength at peak response	λ_{pk}	typ.	800	nm

MECHANICAL DATA

Dimensions in mm

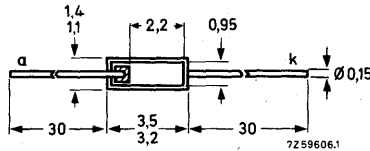

Slice thickness 0,27 mm

RATINGS Limiting values in accordance with the Absolute Maximum System (IEC 134)

Voltage

Reverse voltage V_R max. 18 V

Currents

Forward current I_F max. 5 mA

Dark reverse current I_R max. 2 mA

Temperatures

Storage temperature T_{stg} -65 to +125 °C

Junction temperature T_j max. 125 °C

THERMAL RESISTANCE

From junction to ambient in free air $R_{th\ j-a}$ = 0,5 °C/mW

CHARACTERISTICS

$T_{amb} = 25\text{ °C}$ unless otherwise specified

Dark reverse current

$V_R = 15\text{ V}$ I_d typ. 0,01 μA
< 0,5 μA

$V_R = 15\text{ V}; T_{amb} = 100\text{ °C}$ I_d typ. 0,6 μA
< 4,0 μA

Photovoltaic mode

$E = 1000\text{ lx}; T_c = 2700\text{ K}$ (equivalent to 7,7 mW/cm²)

Light reverse current; $V = 0$ I_1 > 10 μA
typ. 13 μA

Forward voltage; $I = 0$ V_F > 330 mV
typ. 350 mV

Luminous sensitivity with external voltage ¹⁾

$V_R = 15\text{ V}; E = 1000\text{ lx}; T_c = 2700\text{ K}$
(equivalent to 7,7 mW/cm²) N > 10,5 nA/lx
typ. 14 nA/lx

Wavelength at peak response

λ_{pk} typ. 800 nm

Diode capacitance; $f = 500\text{ kHz}$

$V_R = 15\text{ V}$ C_d typ. 90 pF

$V_R = 0$ C_d typ. 300 pF

Cut-off frequency (modulated GaAs source)

f_{co} typ. 500 kHz

¹⁾ The value of light current increases with temperature by an amount approximately equal to the increase in dark current.

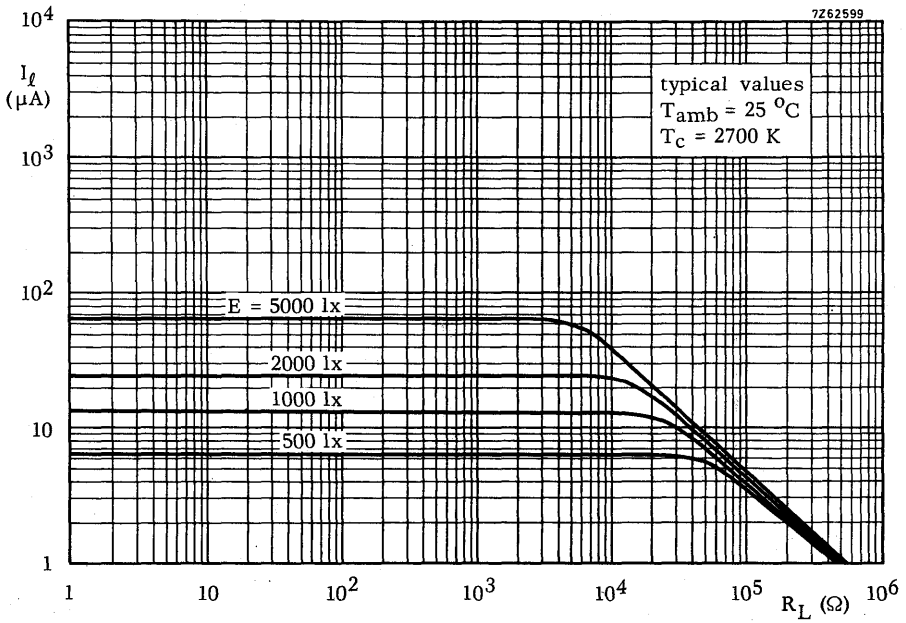
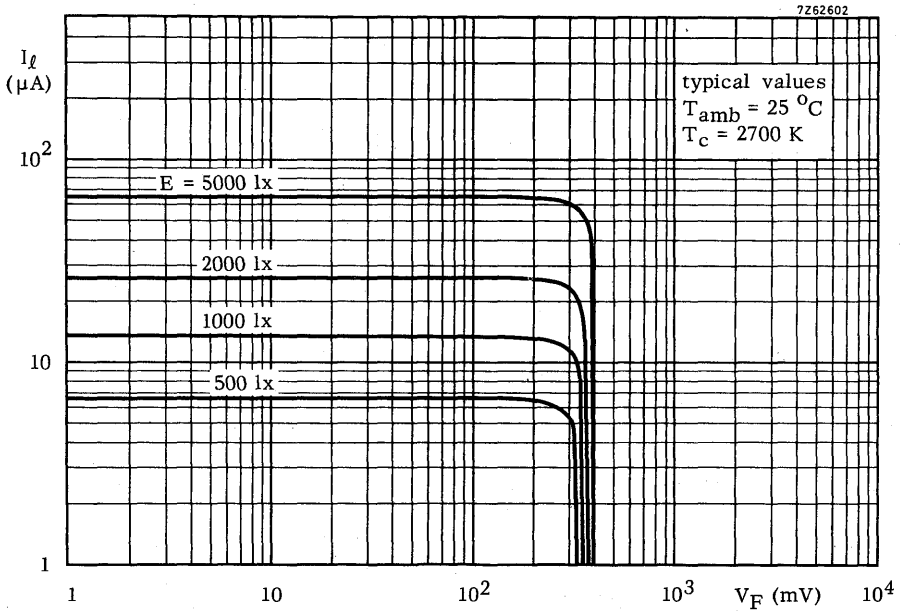

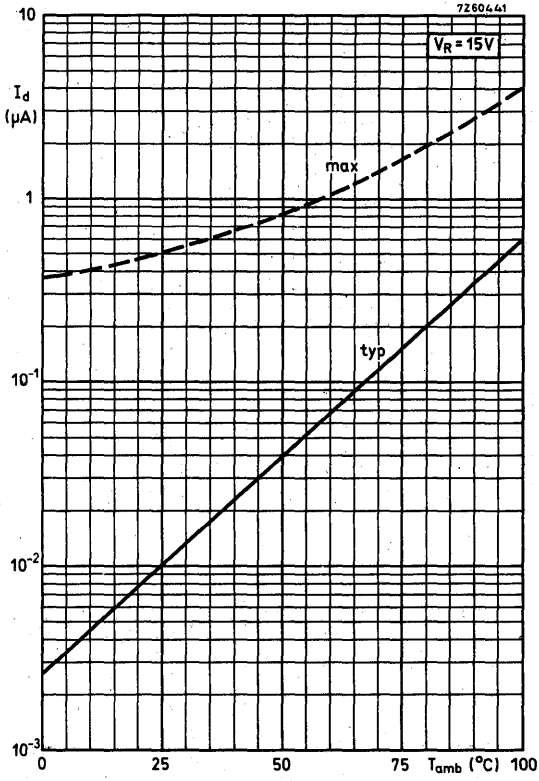

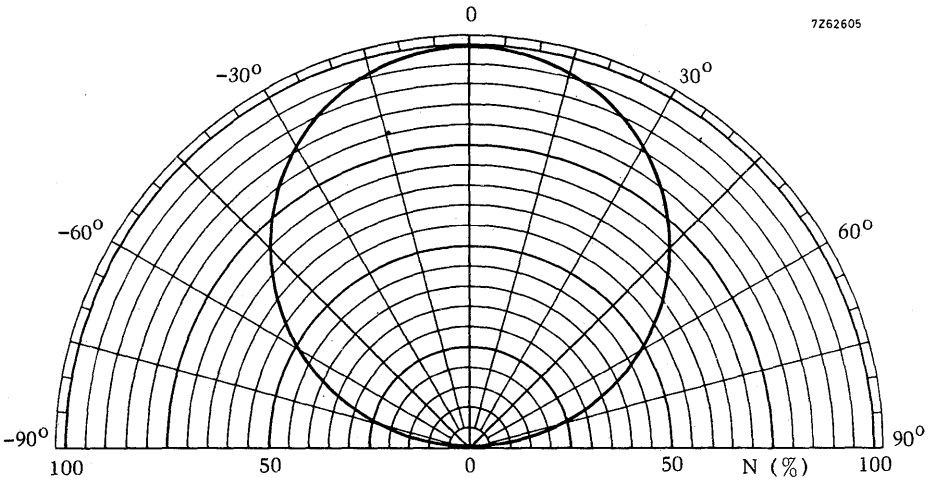
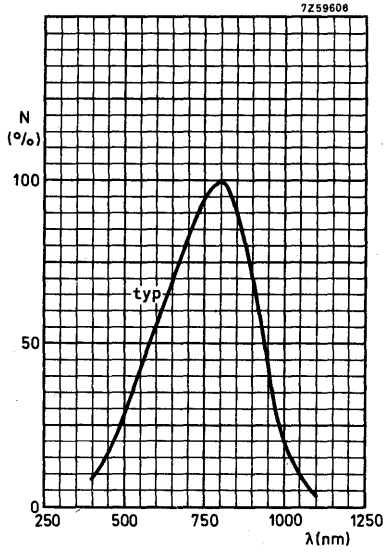



SILICON PLANAR PHOTODIODE

Unencapsulated photodiode for general purpose applications.

QUICK REFERENCE DATA

Reverse voltage	V_R	max.	18 V
Luminous sensitivity $V_R = 15 \text{ V}; E = 1000 \text{ lx}$	N	typ.	40 nA/lx
Dark reverse current at $V_R = 15 \text{ V}$	I_d	<	1 μA
Wavelength at peak response	λ_{pk}	typ.	800 nm

MECHANICAL DATA

Dimensions in mm

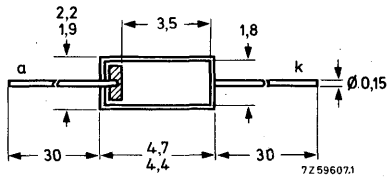

Slice thickness 0,27 mm

RATINGS Limiting values in accordance with the Absolute Maximum System (IEC 134)

Voltage

Reverse voltage V_R max. 18 V

Currents

Forward current I_F max. 10 mA

Dark reverse current I_R max. 5 mA

Temperatures

Storage temperature T_{stg} -65 to +125 °C

Junction temperature T_j max. 125 °C

THERMAL RESISTANCE

From junction to ambient in free air $R_{th\ j-a} = 0,5$ °C/mW

CHARACTERISTICS

$T_{amb} = 25$ °C unless otherwise specified

Dark reverse current

$V_R = 15$ V I_d typ. 0,02 μ A
 $< 1,0$ μ A

$V_R = 15$ V; $T_{amb} = 100$ °C I_d typ. 1,2 μ A
 $< 8,0$ μ A

Photovoltaic mode

$E = 1000$ lx; $T_C = 2700$ K (equivalent to $7,7$ mW/cm²)

Light reverse current; $V = 0$ I_l > 30 μ A
 typ. 38 μ A

Forward voltage; $I = 0$ V_F > 330 mV
 typ. 350 mV

Luminous sensitivity with external voltage ¹⁾

$V_R = 15$ V; $E = 1000$ lx; $T_C = 2700$ K
 (equivalent to $7,7$ mW/cm²) N > 31 nA/lx
 typ. 40 nA/lx

Wavelength at peak response

λ_{pk} typ. 800 nm

Diode capacitance; $f = 500$ kHz

$V_R = 15$ V C_d typ. 250 pF

$V_R = 0$ C_d typ. 800 pF

Cut-off frequency (modulated GaAs source)

f_{co} typ. 500 kHz

¹⁾ The value of light current increases with temperature by an amount approximately equal to the increase in dark current.

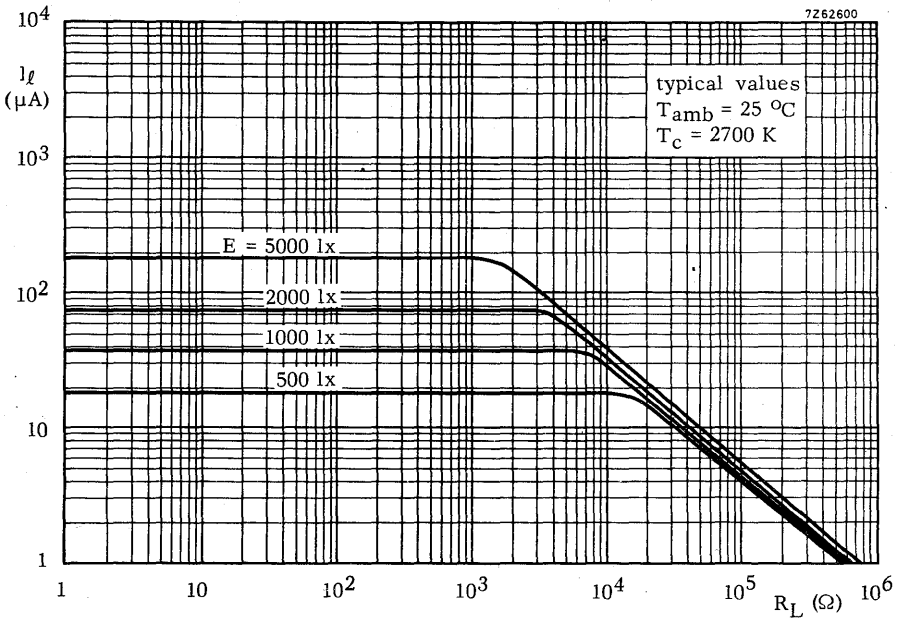
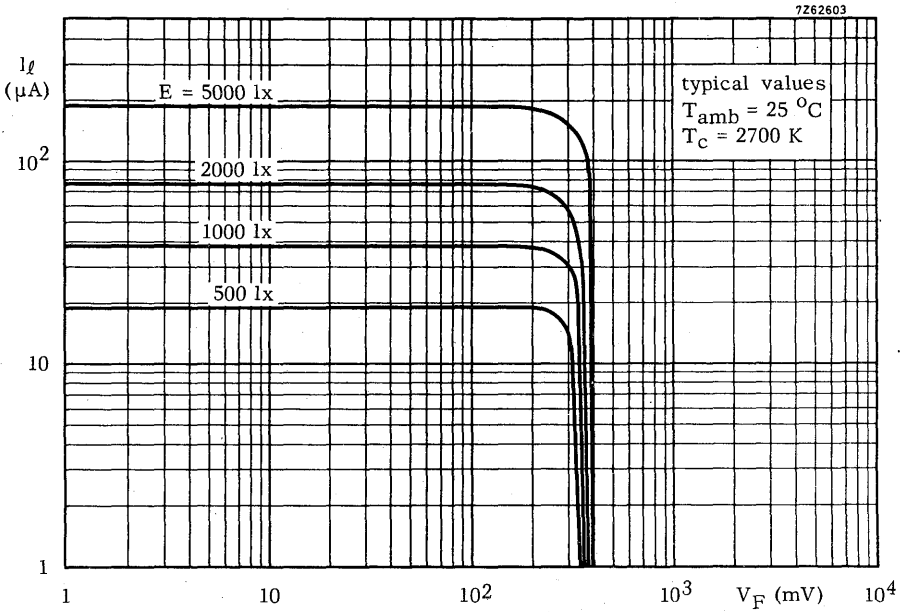

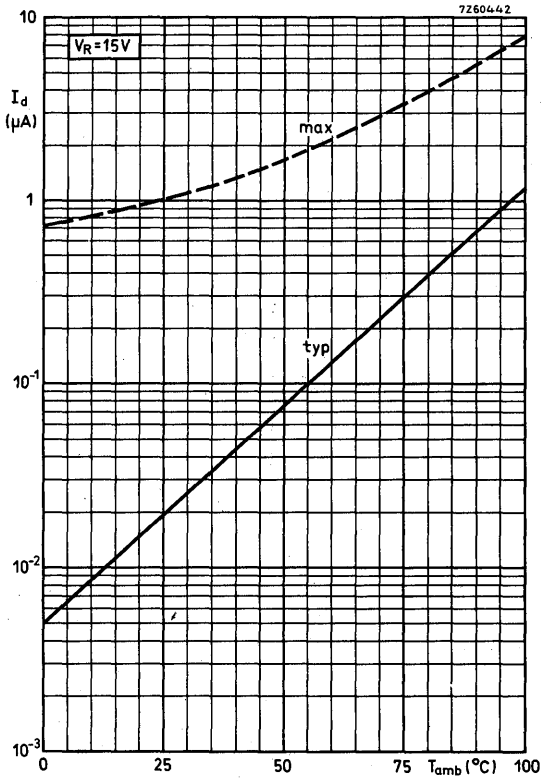

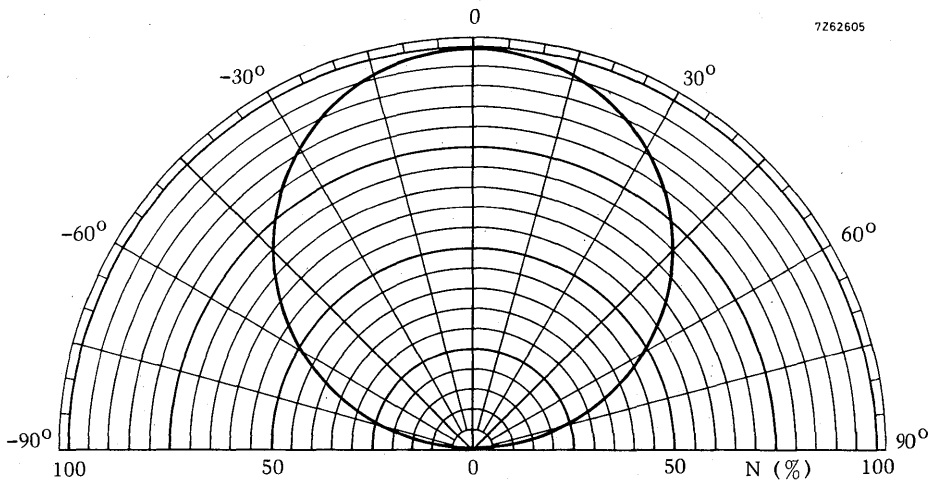
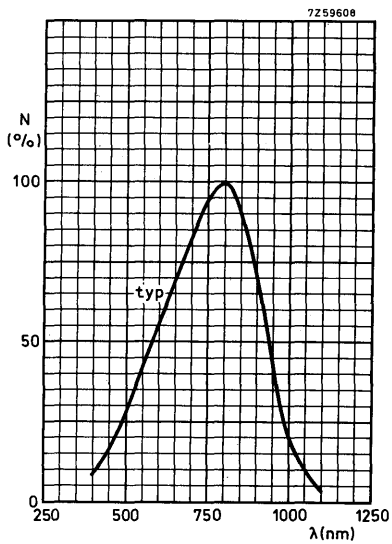

SILICON PLANAR PHOTODIODE

Unencapsulated photodiode for general purpose applications.

QUICK REFERENCE DATA

Reverse voltage	V_R	max. 12 V
Luminous sensitivity $V_R = 10 \text{ V}; E = 1000 \text{ lx}$	N	typ. 150 nA/lx
Dark reverse current at $V_R = 10 \text{ V}$	I_d	< 5 μA
Wavelength at peak response	λ_{pk}	typ. 800 nm

MECHANICAL DATA

Dimensions in mm

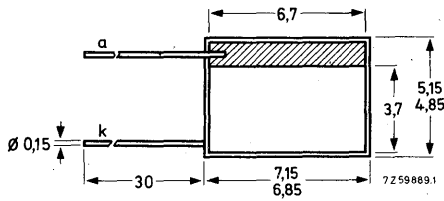

Slice thickness 0,27 mm

RATINGS Limiting values in accordance with the Absolute Maximum System (IEC 134)

Voltage

Reverse voltage V_R max. 12 V

Currents

Forward current I_F max. 50 mA

Dark reverse current I_R max. 20 mA

Temperatures

Storage temperature T_{stg} -65 to +125 °C

Junction temperature T_j max. 125 °C

THERMAL RESISTANCE

From junction to ambient in free air $R_{th\ j-a} = 0,3$ °C/mW

CHARACTERISTICS

$T_{amb} = 25$ °C unless otherwise specified

Dark reverse current

$V_R = 10$ V I_d typ. 0,1 μ A
< 5,0 μ A

$V_R = 10$ V; $T_{amb} = 100$ °C I_d typ. 6,0 μ A
< 40 μ A

Photovoltaic mode

$E = 1000$ lx; $T_C = 2700$ K (equivalent to 7,7 mW/cm²)

Light reverse current; $V = 0$ I_1 > 110 μ A
typ. 140 μ A

Forward voltage; $I = 0$ V_F > 330 mV
typ. 350 mV

Luminous sensitivity with external voltage ¹⁾

$V_R = 10$ V; $E = 1000$ lx; $T_C = 2700$ K
(equivalent to 7,7 mW/cm²) N > 120 nA/lx
typ. 150 nA/lx

Wavelength at peak response

λ_{pk} typ. 800 nm

Diode capacitance; $f = 500$ kHz

$V_R = 10$ V C_d typ. 1000 pF

$V_R = 0$ C_d typ. 3000 pF

Cut-off frequency (modulated GaAs source)

f_{co} typ. 500 kHz

¹⁾ The value of light current increases with temperature by an amount approximately equal to the increase in dark current.

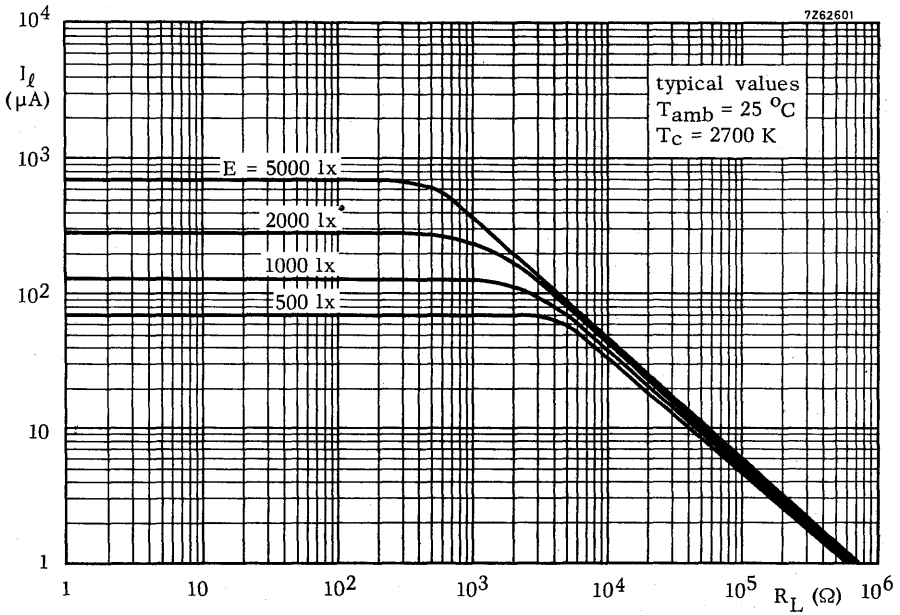
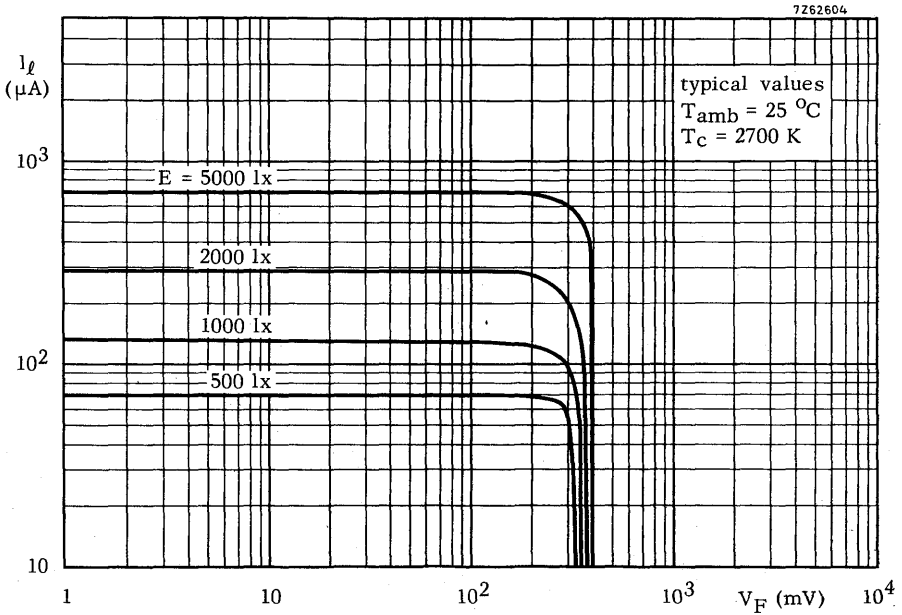

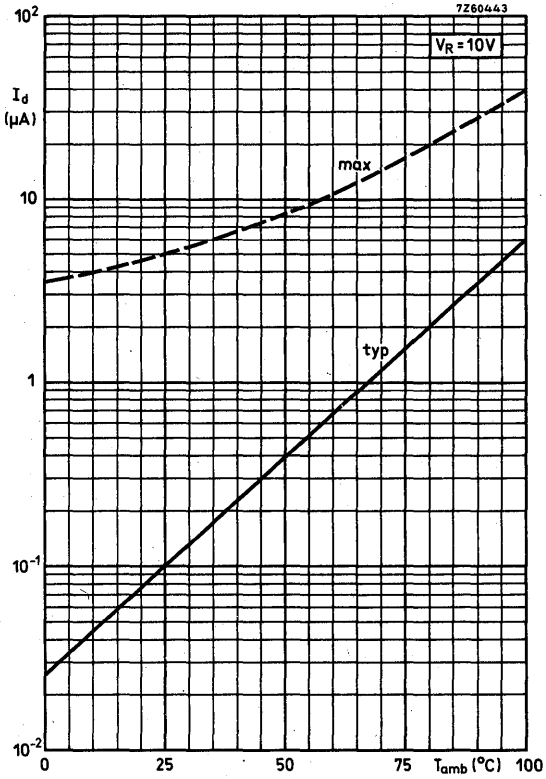

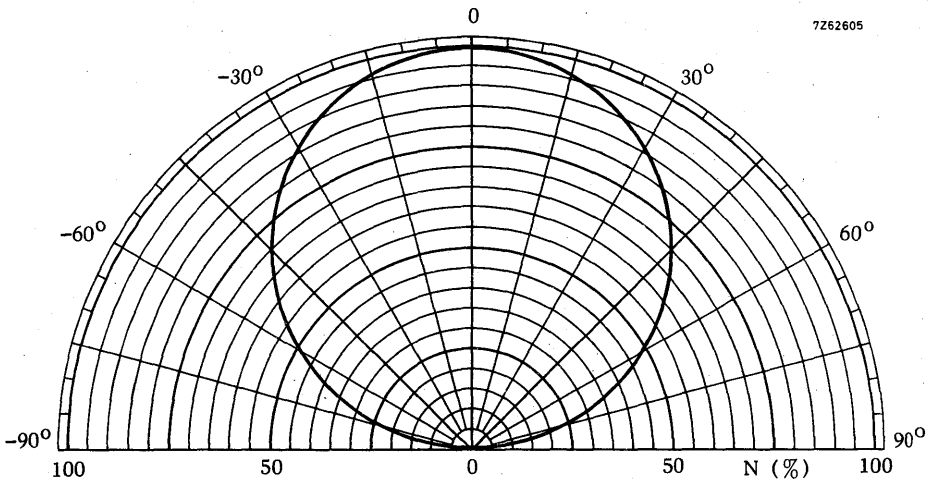
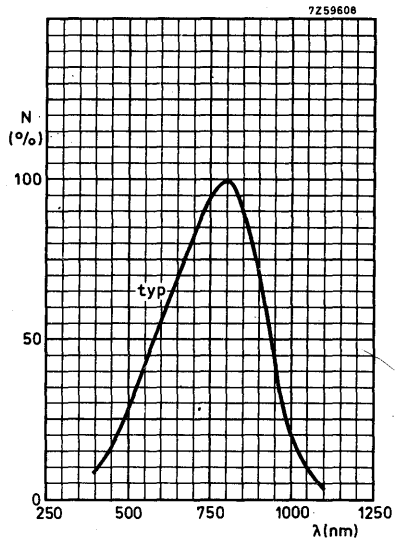

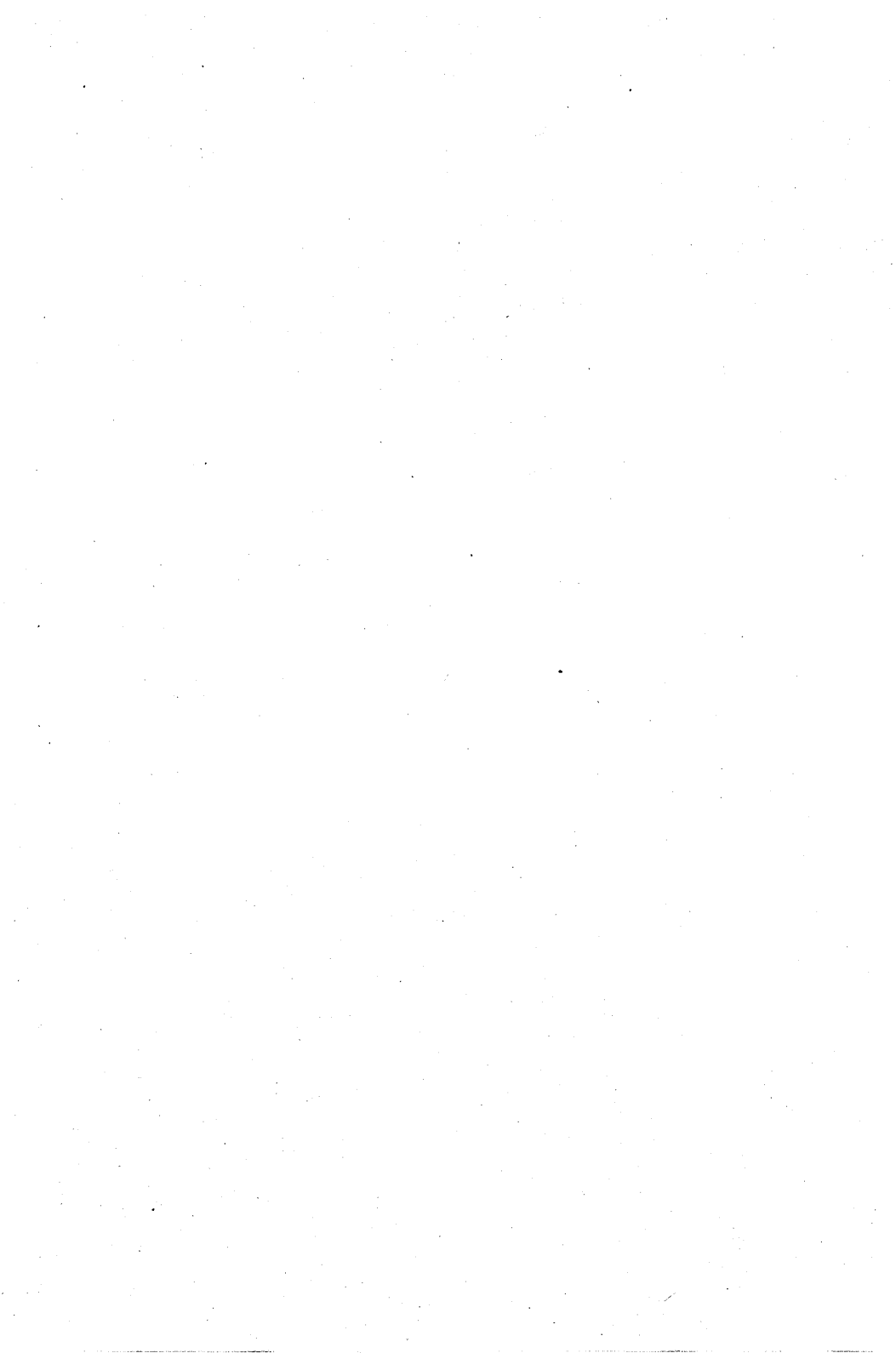

TERRESTRIAL SOLAR MODULE

Module for direct conversion of solar energy into electrical energy. The module contains 34 series-connected solar cells of 57 mm diameter, moulded in transparent resin and mounted between two glass plates. The transparent structure ensures low heating by solar radiation, which maintains efficiency.

The module is suitable for use under severe environmental conditions.

QUICK REFERENCE DATA

At $E_e = 1 \text{ kW/m}^2$ (irradiance from the sun at sea level) and $25 \text{ }^\circ\text{C}$:

Optimum power output at 15,5 V	P_{Lopt} typ.	11 W
Output voltage at optimum operation	V_{opt} typ.	15,5 V
Output current at optimum operation	I_{opt} typ.	700 mA
Dimensions		468 mm x 365 mm x 15 mm

MECHANICAL DATA

Dimensions in mm

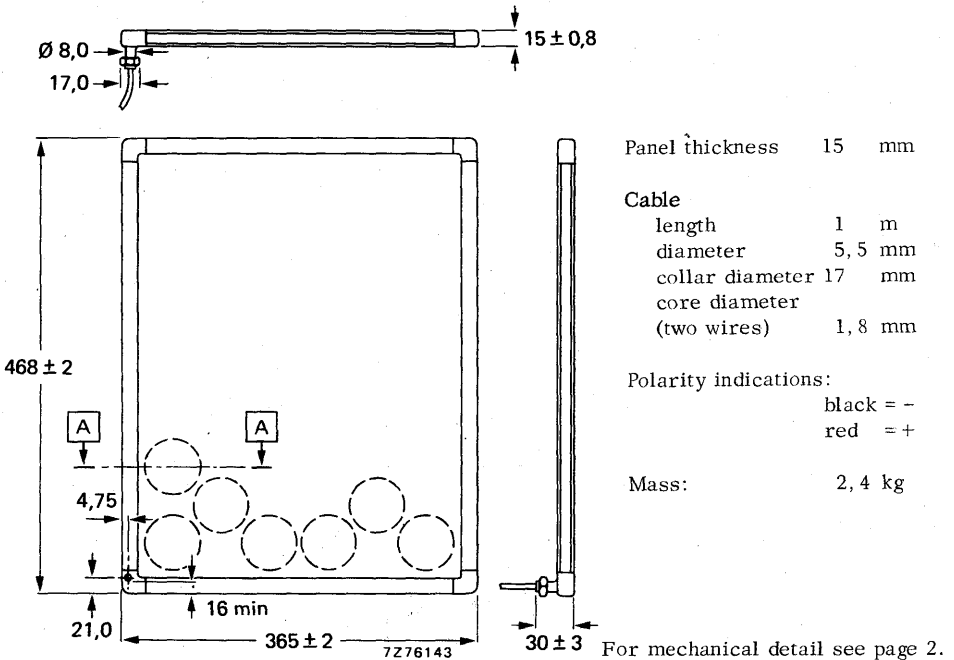

MECHANICAL DATA (continued).

Dimensions in mm

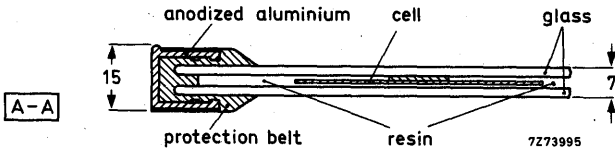

RATINGS Limiting values in accordance with the Absolute Maximum System (IEC 134)

Storage temperature T_{stg} -40 to +85 °C

CHARACTERISTICS at $E_e = 1 \text{ kW/m}^2$ (irradiance from the sun at sea level; A. M. 1)

Cell temperature	T_{cell}	0	25	60 °C
Optimum output power	P_{Lopt} typ.	12	11	9,7 W
Voltage	V_{opt} typ.	18	15,5	14,3 V
Current	I_{opt} typ.	665	>645 700	680 mA
Open-circuit voltage	V_{oc} typ.	22,2	20,5	18,2 V
Short-circuit current	I_{sc} typ.	700	720	740 mA
Temperature coefficient of open-circuit voltage	dV_{oc}/dT	typ.		-74 mV/°C
Temperature coefficient of short-circuit current	dI_{sc}/dT	typ.		0,64 mA/°C

TYPICAL OPERATION BPX47A coupled to a 12 V battery

Irradiance from the sun	E_e	1 kW/m ²
Operating voltage (12 V nominal lead-acid battery; end-of-charge voltage 13,5 V; +0,8 V for blocking diode)	V	14,3 V

At an irradiance of 1 kW/m² the cell temperature rise is 15 °C

At an ambient temperature of 45 °C (cell temperature = 45 + 15 = 60 °C) the module can supply a current of 680 mA to the load.

ENVIRONMENTAL TESTS

The modules are subjected to the following IEC tests and some additional tests:

Test	In accordance with	Conditions
Cold	IAC68-2-1, test Ab	Temperature: -40 °C, duration: 16 h
Rapid change of temperature	IEC68-2-14, test Na	Low temperature: -40 °C High temperature: +85 °C Number of cycles: 10 Duration of exposures: 30 min
Dry heat	IEC68-2-2, test Bb	Temperature: +85 °C Duration: 16 h
Composite temperature/humidity cyclic test	IEC68-2-38, test Z/AD	10 cycles, +25 °C, +65 °C, -10 °C

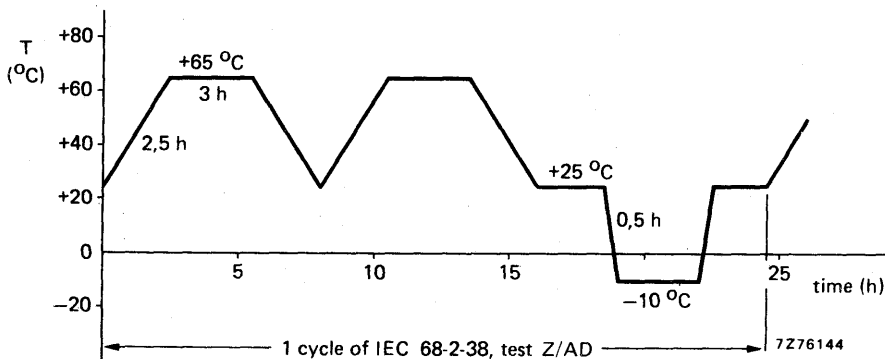

Salt mist	IEC68-2-11, test Ka	Temperature: +35 °C Duration: 48 h
Wind	-	Pressure equivalent to an air velocity of 280 km/h
Sand blown	AIR 7, 303	
Frost with water	-	High temperature: +25 °C Low temperature: -40 °C Duration: 16 h

MOUNTING INSTRUCTIONS

1. The solar panel should be mounted in a metal frame in such a way that only its four metal sides are used for clamping and not the rubber corners. The panel should be electrically insulated from the mounting frame to prevent corrosion.
2. Installation should allow at least a 50 cm space behind the panel to permit a free circulation of air for cooling.
3. The panel should not be installed above hot objects such as roofs.

MOUNTING INSTRUCTIONS (continued)

4. Diode protection is imperative in the series connection of a chain of panels to prevent voltage inversion due to partial shadowing effects.

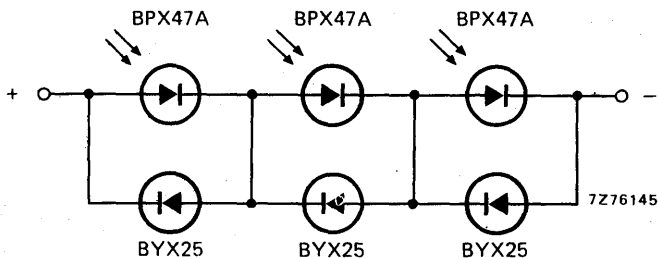

5. If series-connected chains are joined in parallel and diode protected, a matrix interconnection is necessary.

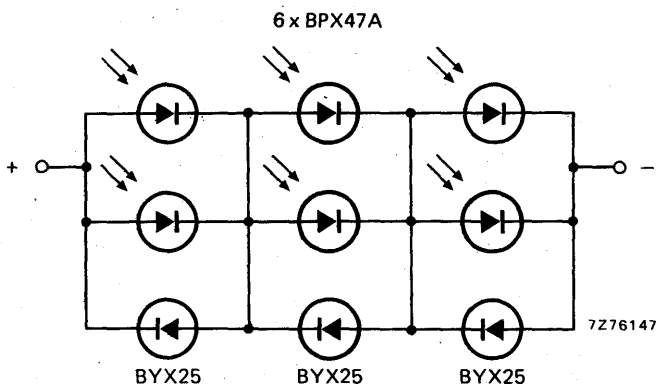

6. A charge regulator containing a series protection diode must be used when connecting panels to a lead acid battery.

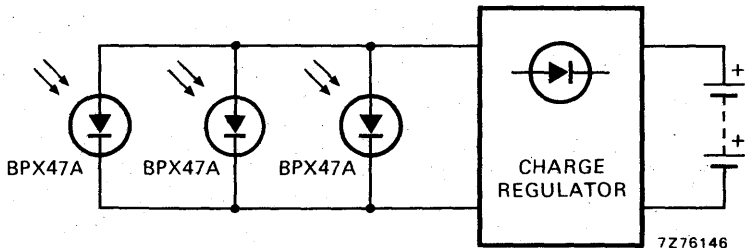

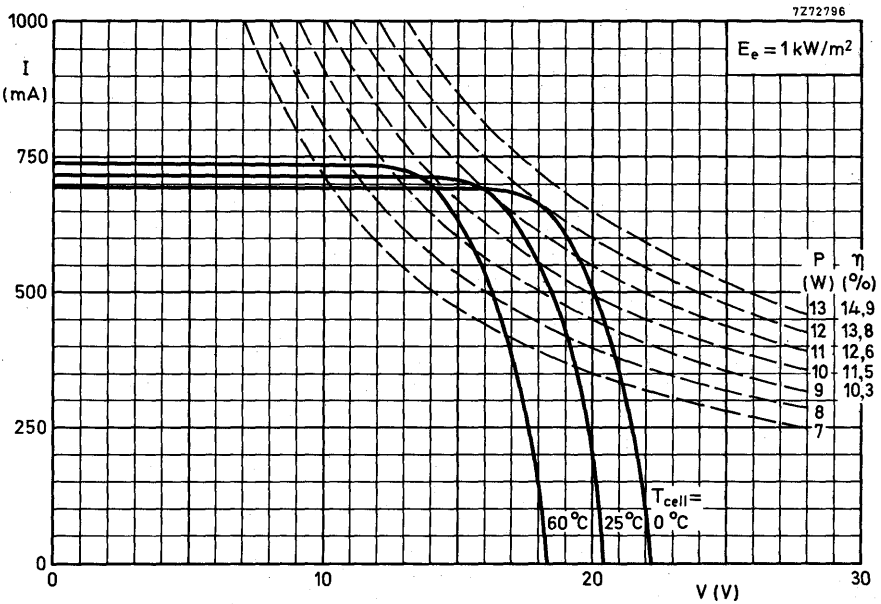
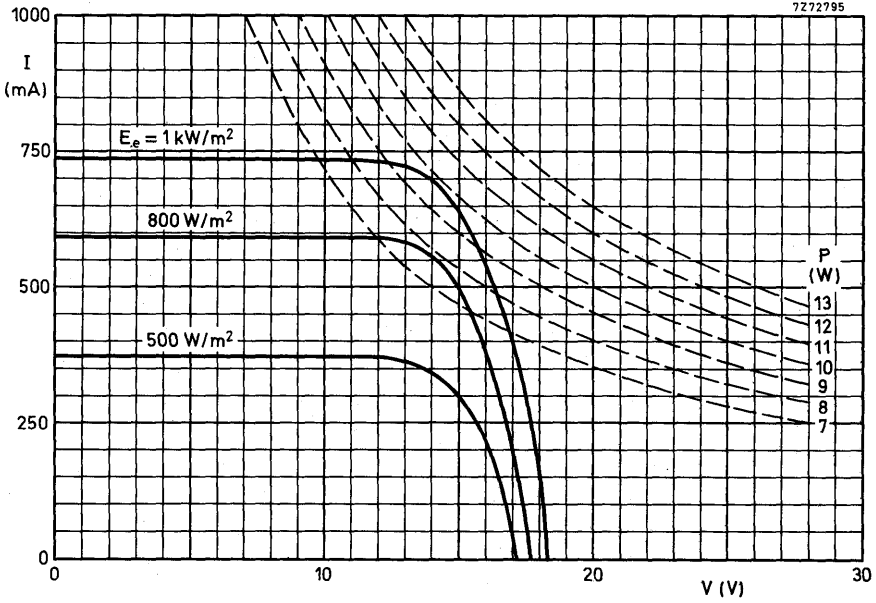

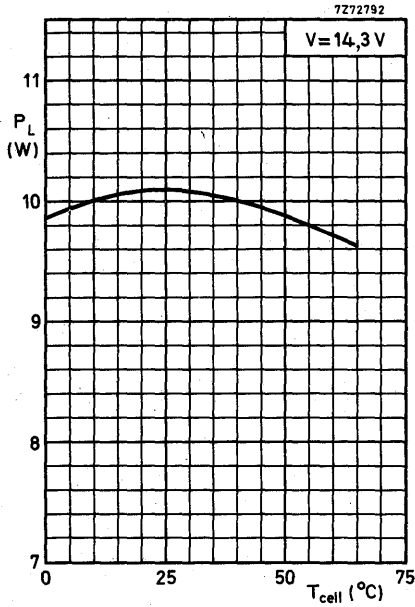
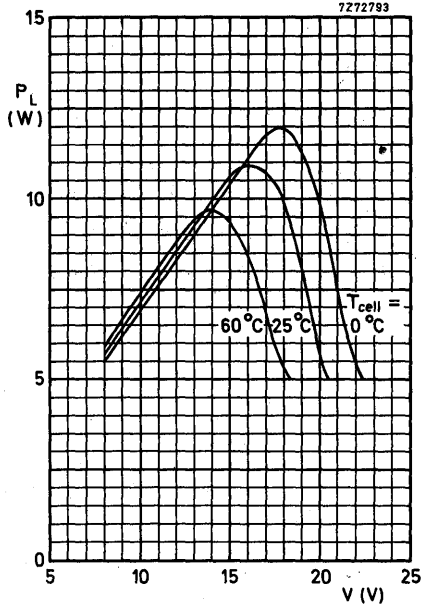

PHOTOTRANSISTOR

General purpose n-p-n silicon phototransistor with a plastic lens.

QUICK REFERENCE DATA

Collector-emitter voltage (open base)	V_{CEO}	max.	30	V
Collector current (d. c.)	I_C	max.	25	mA
Junction temperature	T_j	max.	125	°C
Collector dark current (open base) $V_{CE} = 20$ V	I_d	<	100	nA
Collector light current (open base) $V_{CE} = 5$ V; $E = 1000$ lx (4,75 mW/cm ²)	I_l		100 to 700	μA
	BPX70C	I_l	100 to 300	μA
	BPX70D	I_l	200 to 400	μA
	BPX70E	I_l	300 to 700	μA
Wavelength at peak response	λ_{pk}	typ.	800	nm
Angle between half-sensitivity directions	α	50% typ.	120°	

MECHANICAL DATA

Dimensions in mm

SOT-70

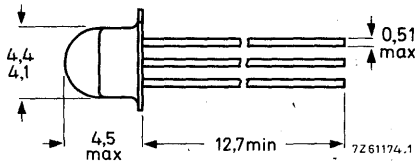
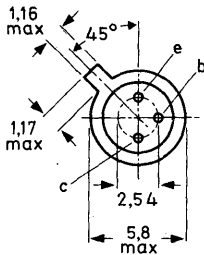

Max. lead diameter is guaranteed only for 12,7 mm

RATINGS Limiting values in accordance with the Absolute Maximum System (IEC 134)

Voltages

Collector-base voltage (open emitter)	V_{CBO}	max.	40 V
Collector-emitter voltage (open base)	V_{CEO}	max.	30 V
Emitter-collector voltage (open base)	V_{ECO}	max.	6 V

Currents

Collector current (d. c.)	I_C	max.	25 mA
Collector current (peak value) $t_p < 50 \mu s; \delta < 0, 1$	I_{CM}	max.	50 mA

Power dissipation

Total power dissipation up to $T_{amb} = 25 \text{ }^\circ\text{C}$	P_{tot}	max.	180 mW
---	-----------	------	--------

Temperatures

Storage temperature	T_{stg}	-40 to +125	$^\circ\text{C}$
Junction temperature	T_j	max.	125 $^\circ\text{C}$

THERMAL RESISTANCE

From junction to ambient in free air	$R_{th j-a}$	=	0,55 $^\circ\text{C}/\text{mW}$
--------------------------------------	--------------	---	---------------------------------

CHARACTERISTICS

$I_B = 0; T_{amb} = 25 \text{ }^\circ\text{C}$ unless otherwise specified

Collector dark current

$V_{CE} = 20 \text{ V}$	I_d	typ.	10 nA
		<	100 nA
$V_{CE} = 20 \text{ V}; T_j = 100 \text{ }^\circ\text{C}$	I_d	typ.	10 μA
		<	100 μA

Collector light current

$V_{CE} = 5 \text{ V}$; tungsten filament lamp source with colour temperature 2856 K;	I_l	100 to 700	$\mu\text{A} \text{ } ^1)$
$E_v = 1000 \text{ lx}$ ($E_e = 4,75 \text{ mW}/\text{cm}^2$)			
$E_v = 2500 \text{ lx}$ ($E_e = 12 \text{ mW}/\text{cm}^2$)	I_l	>	300 μA

¹⁾ Available selections: BPX70C: 100 to 300 μA
 BPX70D: 200 to 400 μA
 BPX70E: 300 to 700 μA

CHARACTERISTICS (continued)

Breakdown voltages

Collector-base voltage

$E = 0; I_C = 0, 1 \text{ mA}$

$V_{(BR)CBO} > 40 \text{ V}$

Collector-emitter voltage

$E = 0; I_C = 1 \text{ mA}$

$V_{(BR)CEO} > 30 \text{ V}$

Emitter-collector voltage

$E = 0; I_C = 0, 1 \text{ mA}$

$V_{(BR)ECO} > 6 \text{ V}$

Collector capacitance

$I_E = I_e = 0; V_{CB} = 20 \text{ V}$

$C_c \text{ typ. } 3,5 \text{ pF}$

Wavelength at peak response

$\lambda_{pk} \text{ typ. } 800 \text{ nm}$

Bandwidth at half height

$B_{50\%} \text{ typ. } 300 \text{ nm}$

Switching times

$I_{Con} = 1 \text{ mA}; V_{CC} = 5 \text{ V}; R_L = 100 \Omega$

Delay time

$t_d \text{ typ. } 1,5 \mu\text{s}$
 $< 3,0 \mu\text{s}$

Rise time

$t_r \text{ typ. } 3,0 \mu\text{s}$
 $< 10 \mu\text{s}$

Storage time

$t_s \text{ typ. } 1,5 \mu\text{s}$
 $< 3,0 \mu\text{s}$

Fall time

$t_f \text{ typ. } 2,0 \mu\text{s}$
 $< 10 \mu\text{s}$

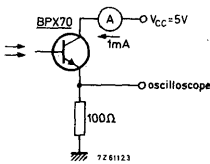

Light input pulse:

$t_r = t_f = 20 \text{ ns}$

$t_p = 20 \mu\text{s}$

$f = 500 \text{ Hz}$

$\lambda = 800 \text{ nm}$

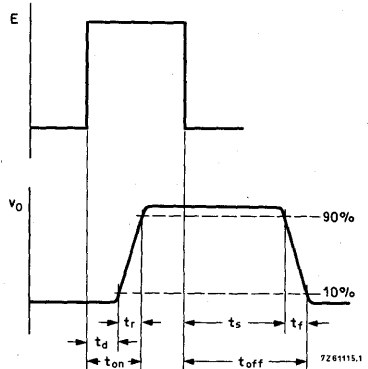

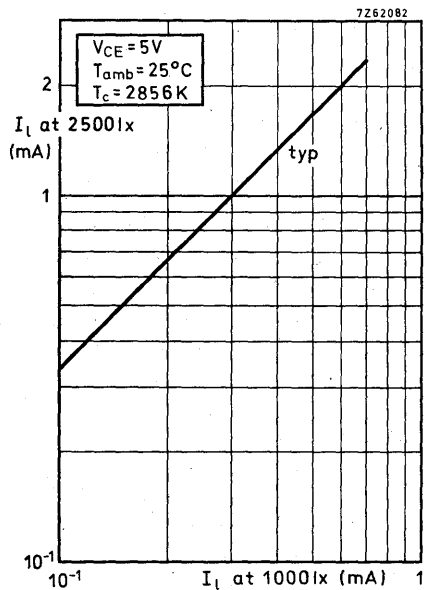
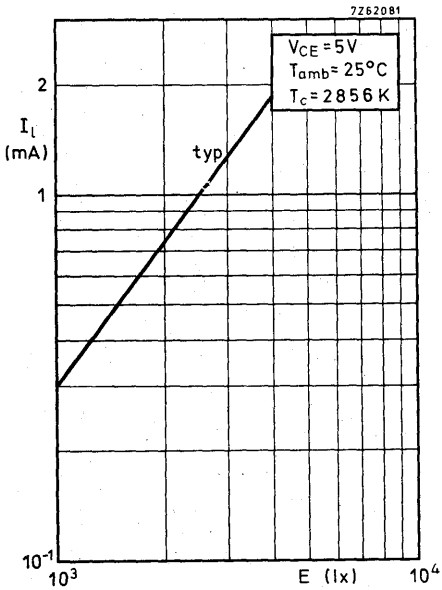
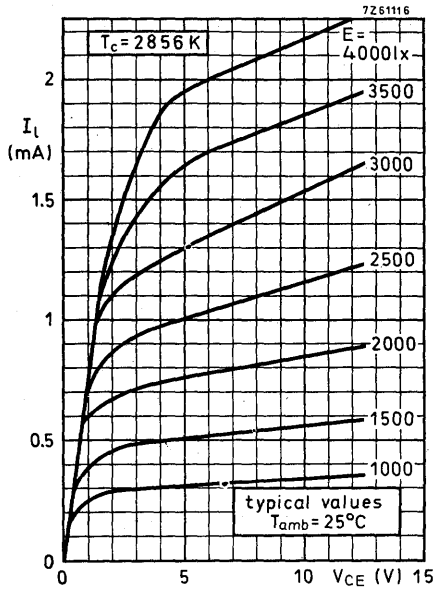

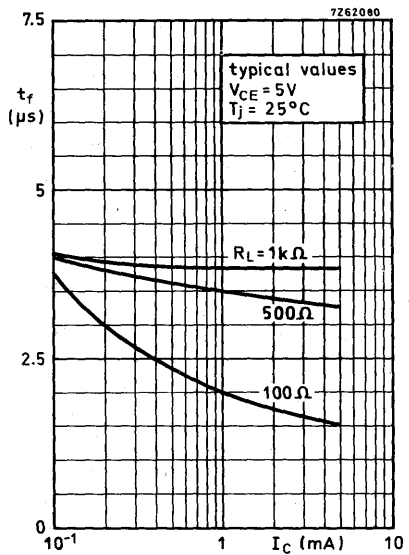
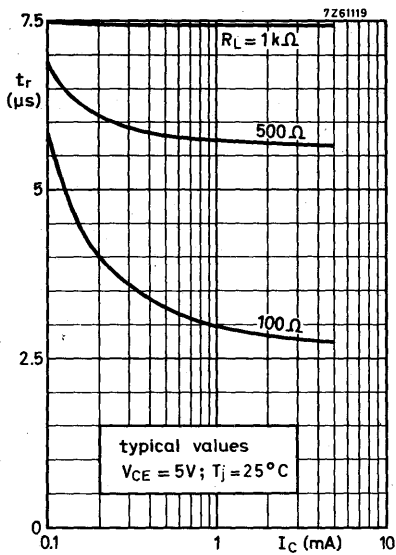
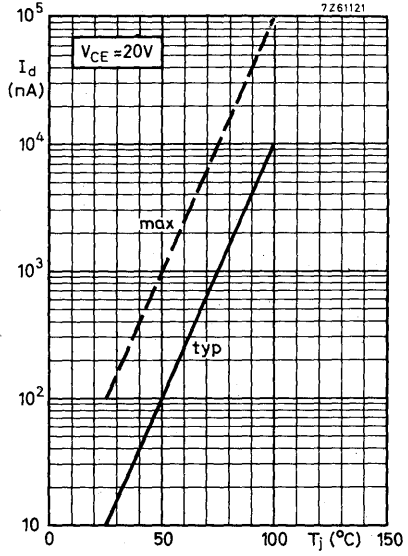
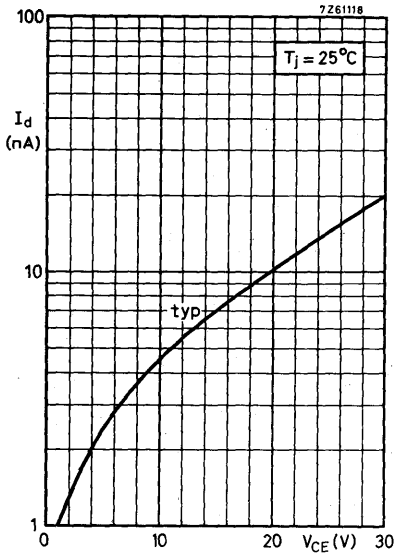

polar response of relative sensitivity

$T_{amb} = 25^{\circ}\text{C}$

7Z61122

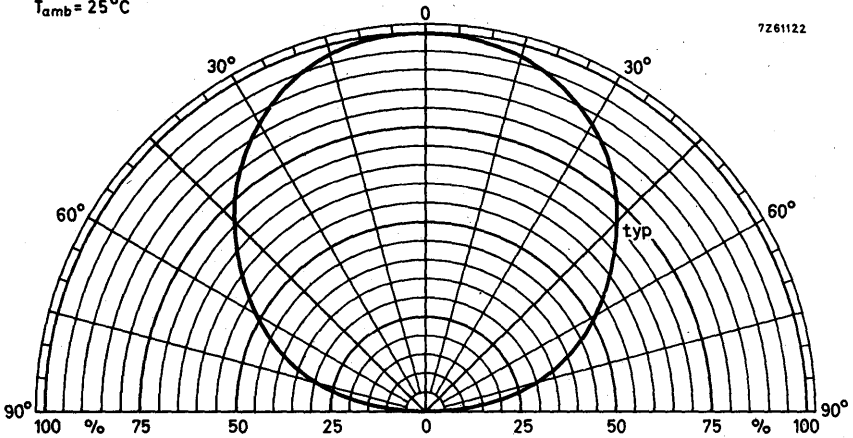

7Z61120

$T_{amb} = 25^{\circ}\text{C}$

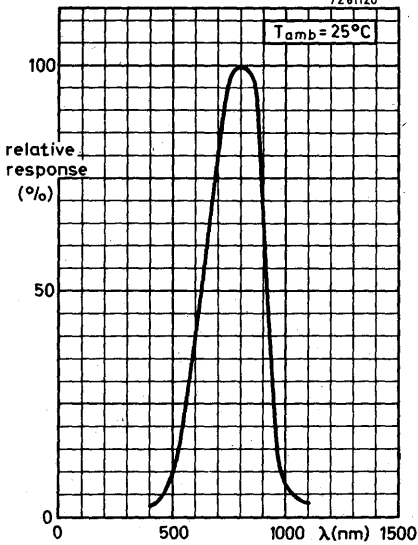

7Z61117

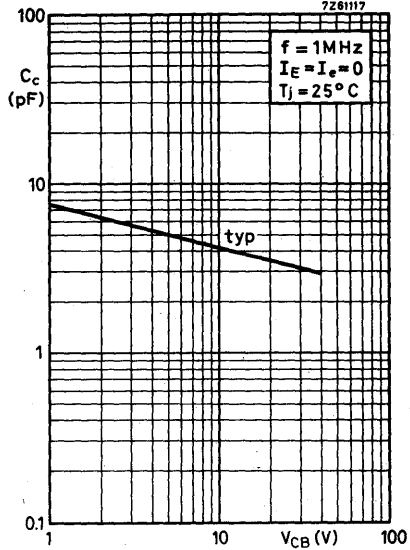

PHOTOTRANSISTOR

General purpose n-p-n silicon phototransistor with a glass lens. Inaccessible base.

QUICK REFERENCE DATA			
Collector-emitter voltage	V_{CEO}	max.	50 V
Collector current (d. c.)	I_C	max.	20 mA
Junction temperature	T_j	max.	150 °C
Collector dark current $V_{CE} = 30$ V	I_d	<	25 nA
Collector light current $V_{CE} = 5$ V; $E_e = 20$ mW/cm ² BPX71	I_l		0,5 to 15 mA
	BPX71-201	I_l	0,5 to 3 mA
	BPX71-202	I_l	2 to 5 mA
	BPX71-203	I_l	4 to 8 mA
	BPX71-204	I_l	7 to 15 mA
Wavelength at peak response	λ_{pk}	typ.	800 nm
Angle between half-sensitivity directions	$\alpha 50\%$	typ.	40°

MECHANICAL DATA

Dimensions in mm

DO-31

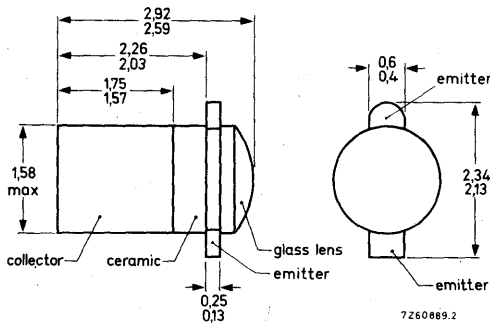

RATINGS Limiting values in accordance with the Absolute Maximum System (IEC 134)

Voltages

Collector-emitter voltage	V_{CEO}	max.	50 V
Emitter-collector voltage	V_{ECO}	max.	7 V

Currents

Collector current (d. c.)	I_C	max.	20 mA
Collector current (peak value) $t_p < 50 \mu s; \delta < 0,1$	I_{CM}	max.	50 mA

Power dissipation

Total power dissipation up to $T_{amb} = 50 \text{ }^\circ\text{C}$ up to $T_{mb} = 55 \text{ }^\circ\text{C}$	P_{tot}	max.	50 mW
	P_{tot}	max.	100 mW

Temperatures

Storage temperature	T_{stg}	-65 to +150	$^\circ\text{C}$
Junction temperature	T_j	max.	150 $^\circ\text{C}$

THERMAL RESISTANCE

From junction to ambient in free air	$R_{th j-a}$	=	2 $^\circ\text{C}/\text{mW}$
From junction to mounting base	$R_{th j-mb}$	=	0,95 $^\circ\text{C}/\text{mW}$

CHARACTERISTICS

$T_{amb} = 25 \text{ }^\circ\text{C}$ unless otherwise specified

Collector dark current

$V_{CE} = 30 \text{ V}$	I_d	<	25 nA
$V_{CE} = 30 \text{ V}; T_{amb} = 100 \text{ }^\circ\text{C}$	I_d	<	100 μA

Collector light current

$V_{CE} = 5 \text{ V};$ tungsten filament lamp source with colour temperature 2856 K; $E_e = 4,75 \text{ mW}/\text{cm}^2$	I_ℓ	typ.	1 mA
$E_e = 20 \text{ mW}/\text{cm}^2$	I_ℓ		0,5 to 15 mA ¹⁾

¹⁾ Available selections : BPX71-201: 0,5 to 3 mA
BPX71-202: 2 to 5 mA
BPX71-203: 4 to 8 mA
BPX71-204: 7 to 15 mA

CHARACTERISTICS (continued)

Breakdown voltages

Collector-emitter voltage

$E = 0; I_C = 0,5 \text{ mA}$

$V_{(BR)CEO} > 50 \text{ V}$

Emitter-collector voltage

$E = 0; I_C = 0,1 \text{ mA}$

$V_{(BR)ECO} > 7 \text{ V}$

Collector-emitter light saturation voltage

$I_C = 0,4 \text{ mA}; E_e = 20 \text{ mW/cm}^2; T_c = 2856 \text{ K}$

$V_{CEsat} \begin{matrix} \text{typ.} & 150 \text{ mV} \\ < & 400 \text{ mV} \end{matrix}$

Wavelength at peak response

$\lambda_{pk} \text{ typ. } 800 \text{ nm}$

Bandwidth at half height

$B_{50\%} \text{ typ. } 400 \text{ nm}$

Switching times

$I_{Con} = 0,8 \text{ mA}; V_{CC} = 35 \text{ V}; R_L = 1 \text{ k}\Omega$

Delay time

$t_d \begin{matrix} \text{typ.} & 2,0 \text{ }\mu\text{s} \\ < & 20 \text{ }\mu\text{s} \end{matrix}$

Rise time

$t_r \begin{matrix} \text{typ.} & 3,0 \text{ }\mu\text{s} \\ < & 30 \text{ }\mu\text{s} \end{matrix}$

Storage time

$t_s \begin{matrix} \text{typ.} & 0,1 \text{ }\mu\text{s} \\ < & 2,0 \text{ }\mu\text{s} \end{matrix}$

Fall time

$t_f \begin{matrix} \text{typ.} & 2,5 \text{ }\mu\text{s} \\ < & 20 \text{ }\mu\text{s} \end{matrix}$

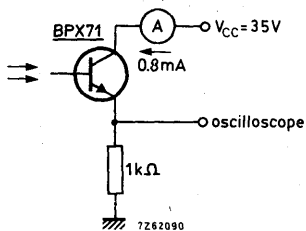

Light input pulse:

$t_r = t_f = 20 \text{ ns}$
 $t_p = 20 \text{ }\mu\text{s}$
 $f = 500 \text{ Hz}$
 $\lambda = 800 \text{ nm}$

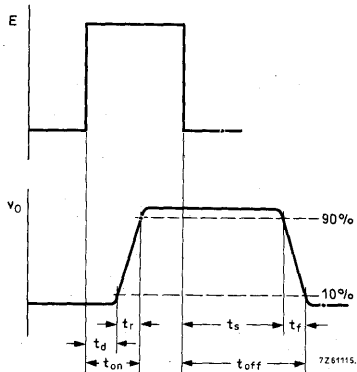

BPX71

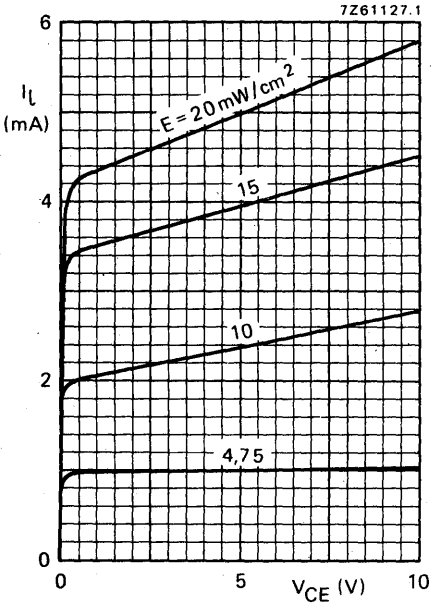

Typical values; $T_{\text{amb}} = 25^\circ\text{C}$.

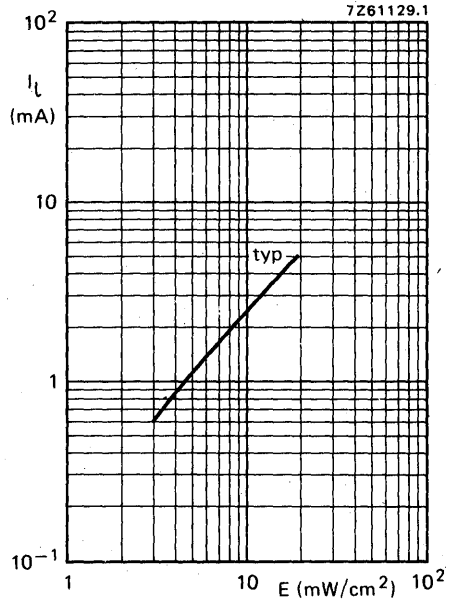

$V_{CE} = 5\text{ V}$; $T_{\text{amb}} = 25^\circ\text{C}$.

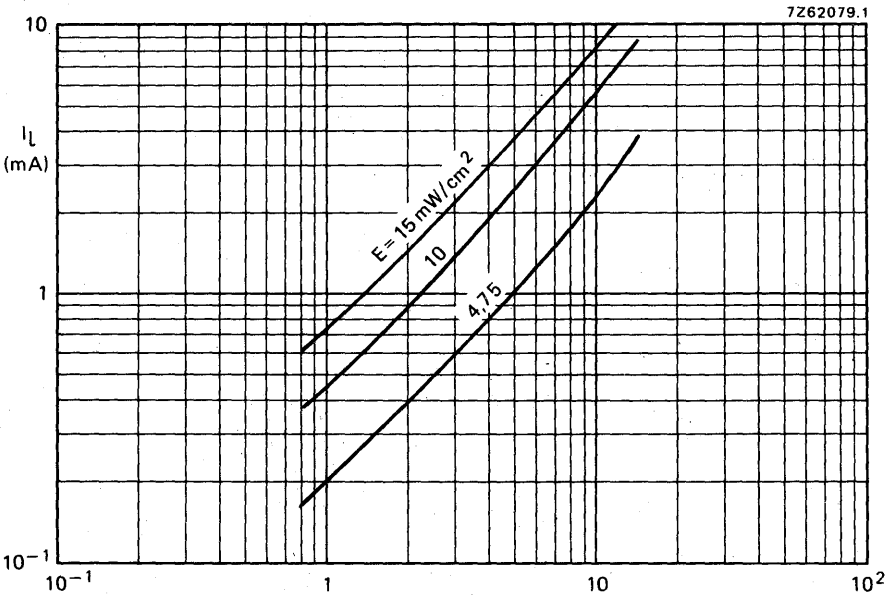

$V_{CE} = 5\text{ V}$; $T_{\text{amb}} = 25^\circ\text{C}$. I_L at $E = 20\text{ mW}/\text{cm}^2$ (mA)

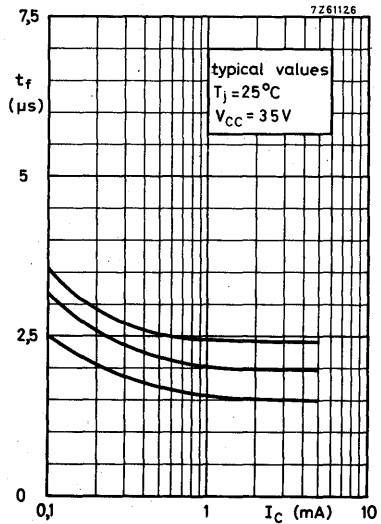
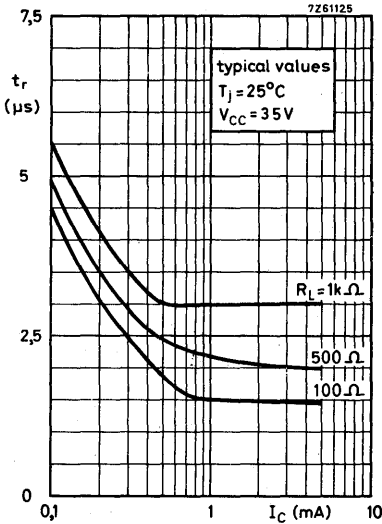
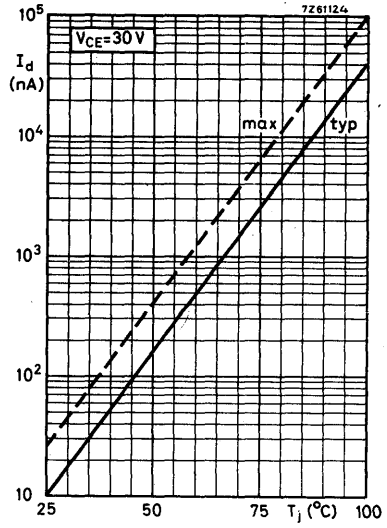
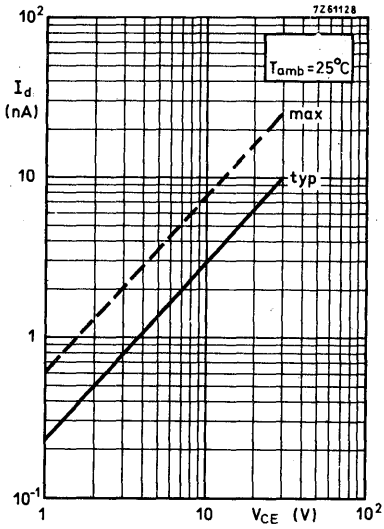

polar response of relative sensitivity

$T_{amb} = 25^{\circ}C$

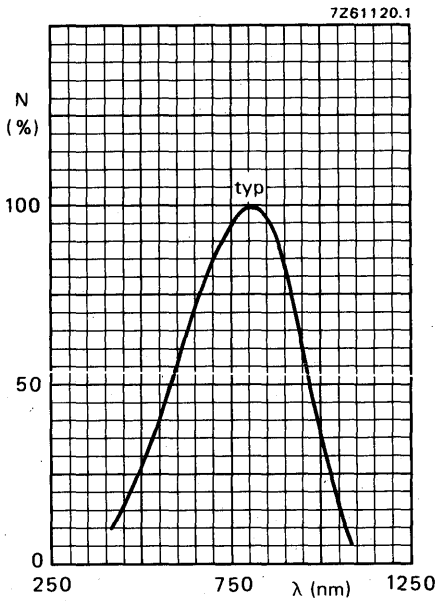
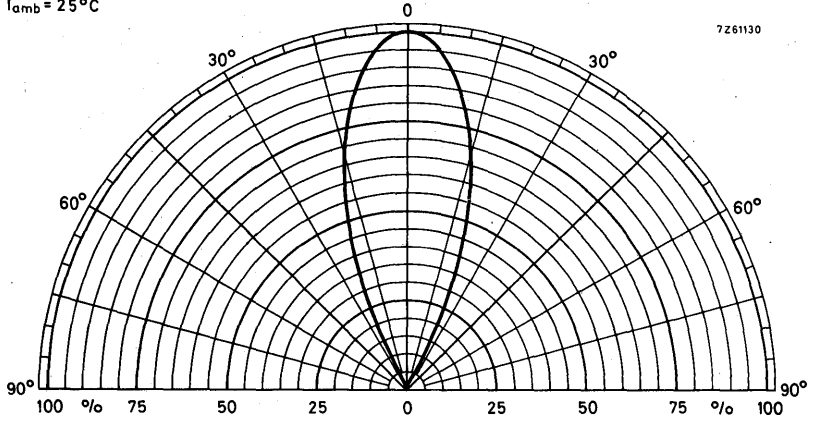

PHOTOTRANSISTOR

General purpose n-p-n silicon phototransistor with a plastic lens.

QUICK REFERENCE DATA

Collector-emitter voltage (open base)	V_{CEO}	max.	30	V
Collector current (d. c.)	I_C	max.	25	mA
Junction temperature	T_j	max.	125	$^{\circ}C$
Collector dark current (open base) $V_{CE} = 20$ V	I_d	<	100	nA
Collector light current (open base) $V_{CE} = 5$ V; $E = 1000$ lx (4,75 mW/cm ²)	BPX72 I_l		500 to 3000	μA
	BPX72C I_l		500 to 1200	μA
	BPX72D I_l		850 to 2000	μA
	BPX72E I_l		1400 to 3000	μA
Wavelength at peak response	λ_{pk}	typ.	800	nm
Angle between half-sensitivity directions	$\alpha_{50\%}$	typ.	120 ^o	

MECHANICAL DATA

Dimensions in mm

SOT-70

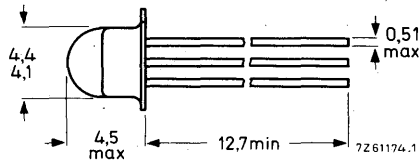
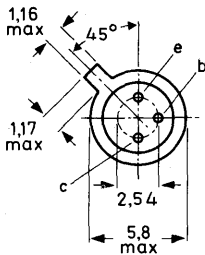

Max. lead diameter is guaranteed only for 12,7 mm

RATINGS Limiting values in accordance with the Absolute Maximum System (IEC 134)

Voltages

Collector-base voltage (open emitter)	V_{CBO}	max.	40 V
Collector-emitter voltage (open base)	V_{CEO}	max.	30 V
Emitter-collector voltage (open base)	V_{ECO}	max.	6 V

Currents

Collector current (d. c.)	I_C	max.	25 mA
Collector current (peak value) $t_p \leq 50 \mu s; \delta \leq 0,1$	I_{CM}	max.	50 mA

Power dissipation

Total power dissipation up to $T_{amb} = 25 \text{ }^\circ\text{C}$	P_{tot}	max.	180 mW
---	-----------	------	--------

Temperatures

Storage temperature	T_{stg}	-40 to +125	$^\circ\text{C}$
Junction temperature	T_j	max.	125 $^\circ\text{C}$

THERMAL RESISTANCE

From junction to ambient in free air	$R_{th j-a}$	=	0,55 $^\circ\text{C}/\text{mW}$
--------------------------------------	--------------	---	---------------------------------

CHARACTERISTICS

$I_B = 0; T_{amb} = 25 \text{ }^\circ\text{C}$ unless otherwise specified

Collector dark current

$V_{CE} = 20 \text{ V}$	I_d	typ.	10 nA
		<	100 nA
$V_{CE} = 20 \text{ V}; T_j = 100 \text{ }^\circ\text{C}$	I_d	typ.	10 μA
		<	100 μA

Collector light current

$V_{CE} = 5 \text{ V};$ tungsten filament lamp source with colour temperature 2856 K; $E_v = 1000 \text{ lx}$ ($E_e = 4,75 \text{ mW}/\text{cm}^2$)	I_l	500 to 3000	μA I_l
$E_v = 2500 \text{ lx}$ ($E_e = 12 \text{ mW}/\text{cm}^2$)	I_l	typ.	3000 μA

I_l) Available selections: BPX72C: 500 to 1200 μA
BPX72D: 850 to 2000 μA
BPX72E: 1400 to 3000 μA

CHARACTERISTICS (continued)

Breakdown voltages

Collector-base voltage

$E = 0; I_C = 0, 1 \text{ mA}$

$V_{(BR)CBO} > 40 \text{ V}$

Collector-emitter voltage

$E = 0; I_C = 1 \text{ mA}$

$V_{(BR)CEO} > 30 \text{ V}$

Emitter-collector voltage

$E = 0; I_C = 0, 1 \text{ mA}$

$V_{(BR)ECO} > 6 \text{ V}$

Collector capacitance

$I_E = I_e = 0; V_{CB} = 20 \text{ V}$

$C_c \text{ typ. } 3,5 \text{ pF}$

Wavelength at peak response

$\lambda_{pk} \text{ typ. } 800 \text{ nm}$

Bandwidth at half height

$B_{50\%} \text{ typ. } 300 \text{ nm}$

Switching times

$I_{Con} = 1 \text{ mA}; V_{CC} = 5 \text{ V}; R_L = 100 \Omega$

Delay time

$t_d \text{ typ. } 3,0 \mu\text{s}$
 $< 6,0 \mu\text{s}$

Rise time

$t_r \text{ typ. } 6,0 \mu\text{s}$
 $< 20 \mu\text{s}$

Storage time

$t_s \text{ typ. } 1,5 \mu\text{s}$
 $< 3,0 \mu\text{s}$

Fall time

$t_f \text{ typ. } 4,0 \mu\text{s}$
 $< 20 \mu\text{s}$

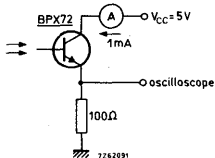

Light input pulse:

$t_r = t_f = 20 \text{ ns}$
 $t_p = 20 \mu\text{s}$
 $f = 500 \text{ Hz}$
 $\lambda = 800 \text{ nm}$

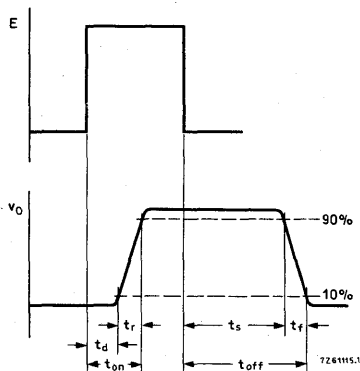

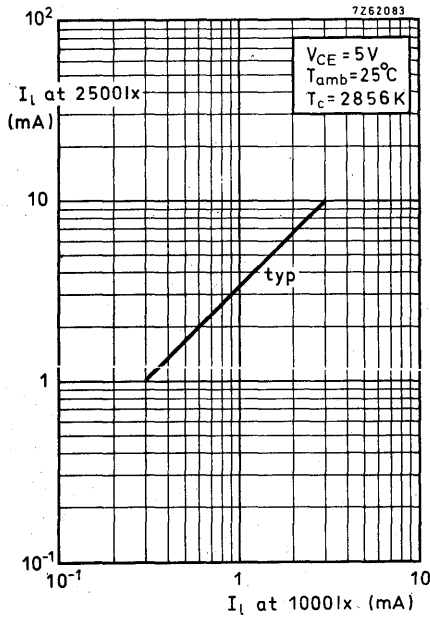
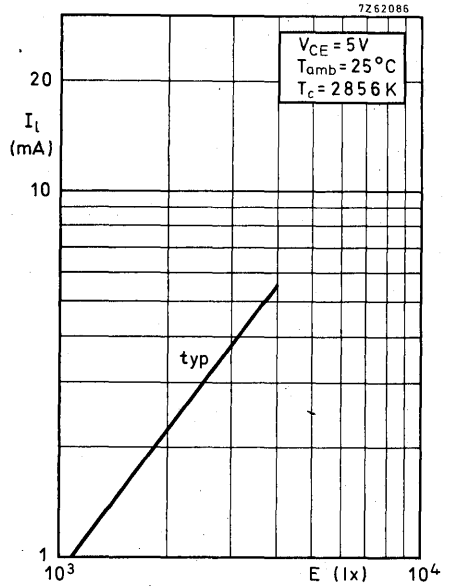
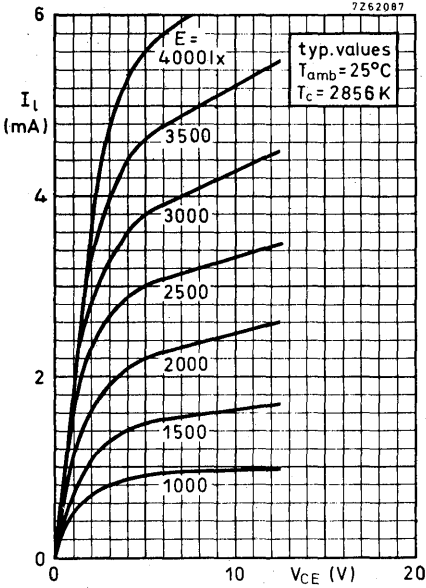

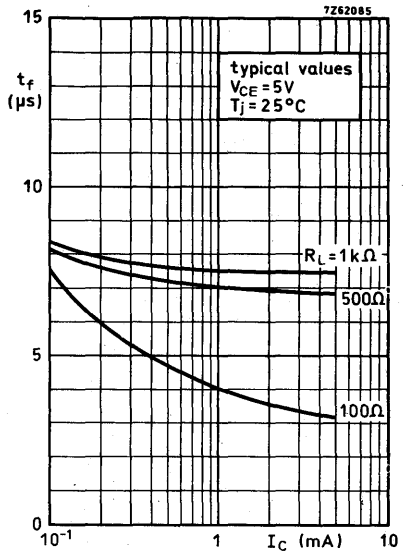
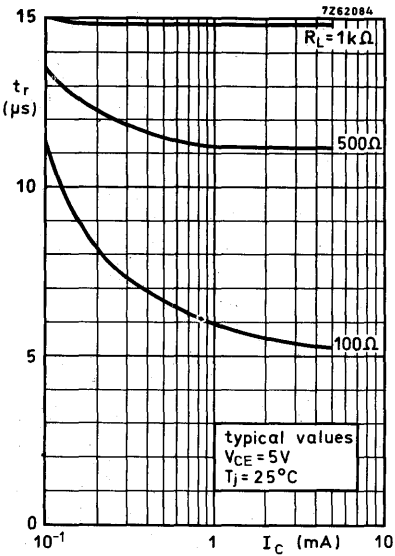
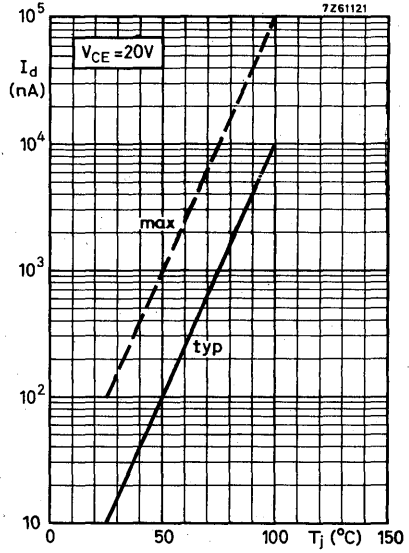
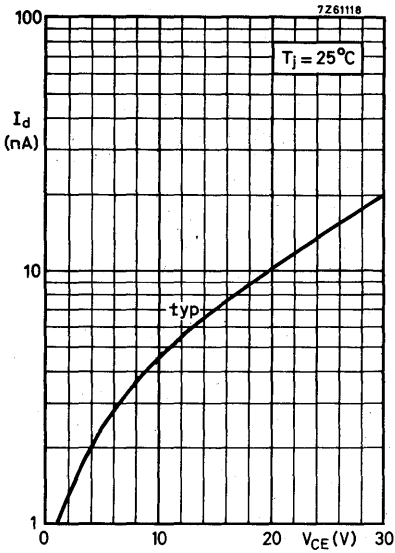

polar response of relative sensitivity

$T_{amb} = 25^{\circ}C$

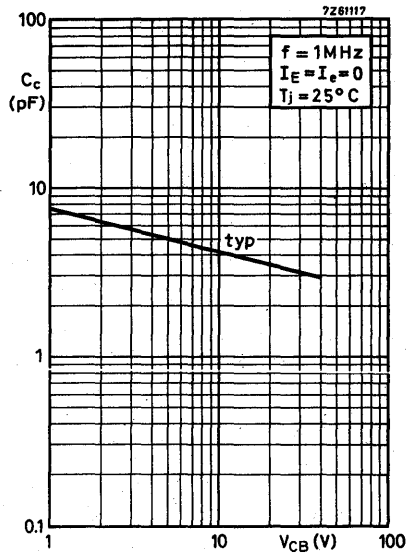
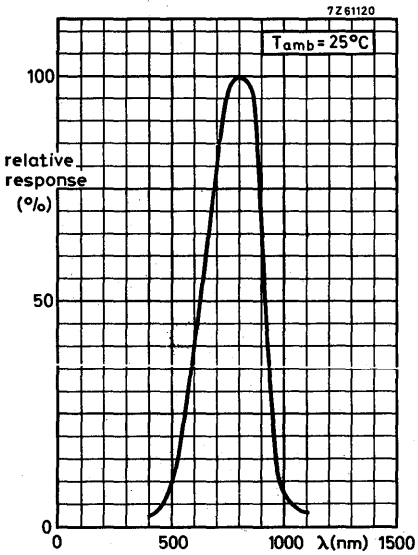
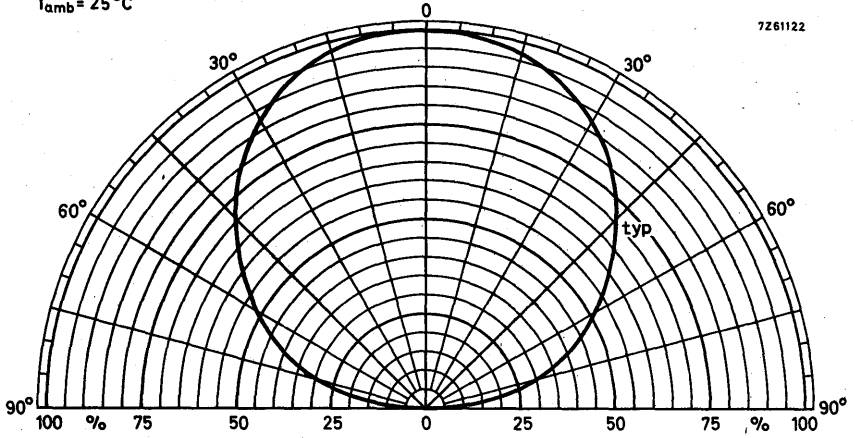

SILICON PHOTODIODE

Silicon photodiode with low N. E. P. for detection of very low light levels; for use in conjunction with an operational amplifier.

QUICK REFERENCE DATA			
Continuous reverse voltage	V_R	max.	18 V
Dark reverse current ($V_R = 1$ V)	$I_R(D)$	typ.	100 pA
Luminous sensitivity $V_R = 0$; $T_C = 2700$ K	N	typ.	8 nA
		typ.	$1 \mu A/mW/cm^2$
Wavelength at peak response	λ_{pk}	typ.	800 nm
Beamwidth between half-sensitivity directions	$\alpha 50\%$	typ.	63°
Sensitive area	A	typ.	1,2 mm x 1,2 mm

MECHANICAL DATA

Dimensions in mm

TO-18, except for window

Cathode connected to case

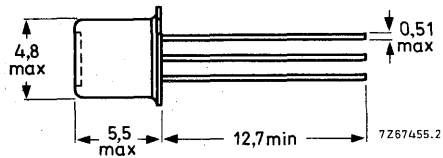
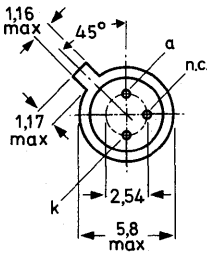

Sensitive area 1,2 mm x 1,2 mm

RATINGS Limiting values in accordance with the Absolute Maximum System (IEC 134)

Continuous reverse voltage	V_R	max.	18	V
Total power dissipation up to $T_{amb} = 25\text{ }^\circ\text{C}$	P_{tot}	max.	300	mW
Storage temperature	T_{stg}		-65 to +150	$^\circ\text{C}$
Junction temperature	T_j	max.	150	$^\circ\text{C}$

CHARACTERISTICS

$T_{amb} = 25\text{ }^\circ\text{C}$

Dark reverse current

$V_R = 1\text{ V}$	$I_R(D)$	typ.	100	pA
--------------------	----------	------	-----	----

Luminous sensitivity (in photovoltaic mode)

$V_R = 0; T_c = 2700\text{ K } 1)$	N	typ.	8	nA/lx
		typ.	1	$\mu\text{A/mW/cm}^2$
$V_R = 0; \lambda = 780\text{ nm}$	N	typ.	0,5	A/W

Wavelength at peak response

λ_{pk}	typ.	800	nm
----------------	------	-----	----

Beamwidth between half-sensitivity directions

$\alpha_{50\%}$	typ.	63	$^\circ$
-----------------	------	----	----------

Diode capacitance

$V_R = 0$	C_d	typ.	200	pF
$V_R = 15\text{ V}$	C_d	typ.	45	pF

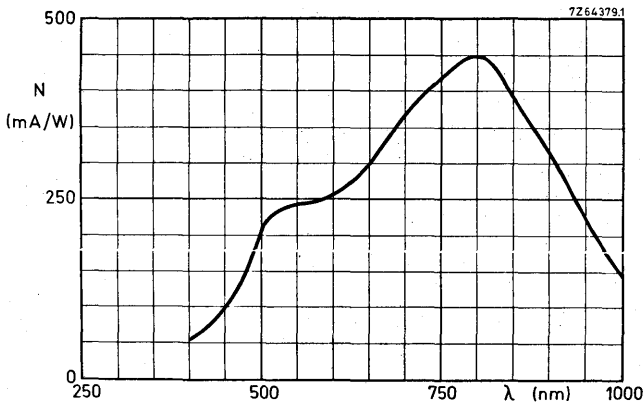

1) Unfiltered tungsten lamp.

APPLICATION INFORMATION

Owing to the improvement over the last few years in the properties of both devices, the photodiode/op amp sensor has become a powerful competitor of the photomultiplier tube. Benefits over the latter are:

- greater range of incident light intensity over which non-linearity is 1% or less: nine decades, as compared to seven decades for the photomultiplier.
- drift in sensitivity over six months about 0,5%, as against 1% to 2% for photomultipliers selected for low drift.
- wide range of spectral response (400 nm to 1200 nm) covered with a single detector: better ability to withstand over-current due to excessive radiation.
- high shock and vibration resistance.
- cheaper power supply (15 V unstabilized as compared to an accurately stabilized high-voltage supply - 1000 V - for photomultiplier.

It has been found that the following circuit with an operational amplifier and a balanced pre-amplifier FET stage is suitable for measuring very low light levels:

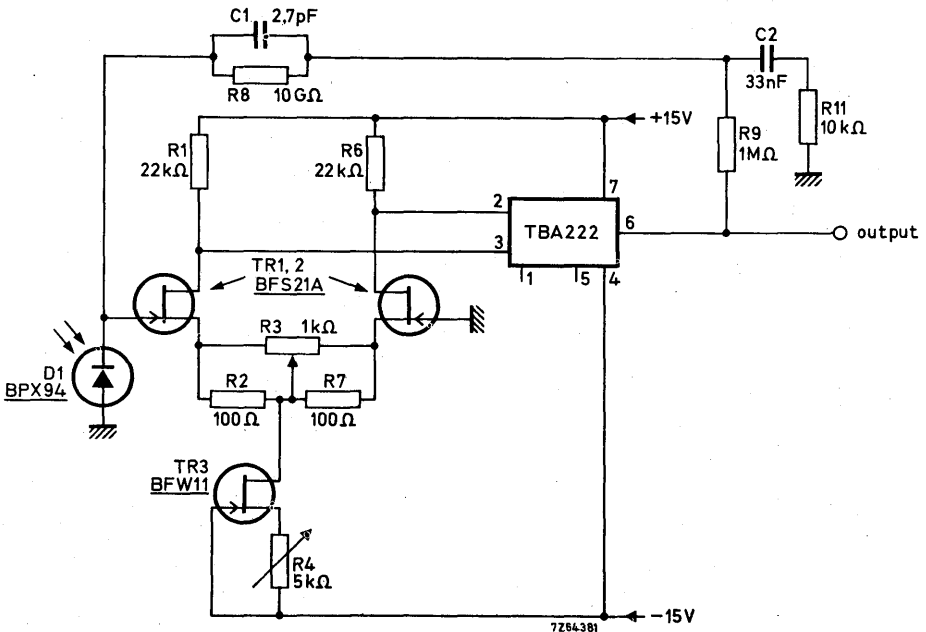

This is an example of an extremely sensitive circuit. Where the amplification may be lower, the value of R₈ can be reduced. The output voltage drops 3 dB at 1 kHz.

SILICON PLANAR EPITAXIAL PHOTOTRANSISTOR

N-P-N phototransistor designed for use as detector. Clear epoxy encapsulation.

QUICK REFERENCE DATA

Collector-emitter voltage (open base)	V_{CEO}	max.	30 V
Collector current (d.c.)	I_C	max.	25 mA
Total power dissipation up to $T_{amb} = 25\text{ }^\circ\text{C}$	P_{tot}	max.	100 mW
Collector light (cut-off) current $V_{CE} = 5\text{ V}; E_V = 1000\text{ lx}$	$I_{CEO(L)}$	>	5 mA
Wavelength at peak response	λ_{pk}	typ.	800 nm

MECHANICAL DATA

Dimensions in mm

Fig. 1 SOD-63.

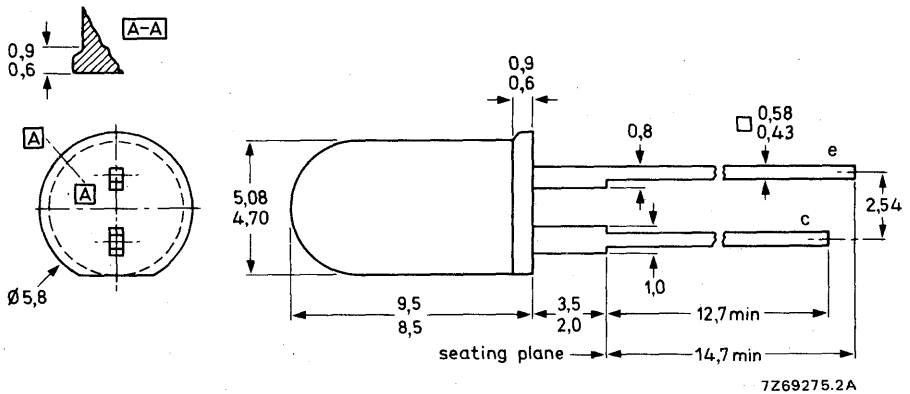

RATINGS

Limiting values in accordance with the Absolute Maximum System (IEC 134)

Collector-emitter voltage (open base)	V_{CEO}	max.	30 V
Emitter-collector voltage (open base)	V_{ECO}	max.	5 V
Collector current (d.c.)	I_C	max.	25 mA
Collector current (peak value) $t_p = 50 \mu s$; $\delta = 0,1$	I_{CM}	max.	50 mA
Total power dissipation up to $T_{amb} = 25^\circ C$	P_{tot}	max.	100 mW
Storage temperature	T_{stg}		-40 to +100 $^\circ C$
Junction temperature	T_j	max.	100 $^\circ C$
Lead soldering temperature up to the seating plane; $t_{slid} < 10 s$	T_{slid}	max.	240 $^\circ C$

THERMAL RESISTANCE

From junction to ambient	$R_{th j-a}$	=	0,75 $^\circ C/mW$
From junction to ambient, device mounted on a printed-circuit board (note 1)	$R_{th j-a}$	=	0,50 $^\circ C/mW$

CHARACTERISTICS

 $T_j = 25^\circ C$ unless otherwise specified

Collector dark (cut-off) current $V_{CE} = 20 V$	$I_{CEO(D)}$	<	100 nA
Collector light (cut-off) current at $T_{amb} = 25^\circ C$ $V_{CE} = 5 V$; $E_v = 1000 lx$; $T_c = 2854 K$ (note 2)	$I_{CEO(L)}$	>	5 mA
Collector-emitter saturation voltage $I_C = 3 mA$; $E_v = 1000 lx$; $T_c = 2854 K$ (note 2)	V_{CEsat}	<	0,4 V
Wavelength at peak response	λ_{pk}	typ.	800 nm
Bandwidth at half height	$B_{50\%}$	typ.	400 nm
Angle between half-sensitivity directions (note 3)	$\alpha_{50\%}$	typ.	25°
Receiving area		typ.	1 mm ²

Notes

1. With copper island rings of 0,8 mm and 1,3 mm diameters on both sides of 1,6 mm glass-epoxy printed-circuit board; thickness of copper 35 μm .
2. Unfiltered tungsten filament lamp.
3. Measured at $I_C = 1 mA$; $E_v = 1000 lx$.

Switching times (see Figs 2 and 3)

$I_{Con} = 1 \text{ mA}$; $V_{CC} = 5 \text{ V}$; $R_E = 100 \Omega$; $T_{amb} = 25 \text{ }^\circ\text{C}$

Light current rise time

t_r typ. 3 μs

Light current fall time

t_f typ. 2 μs

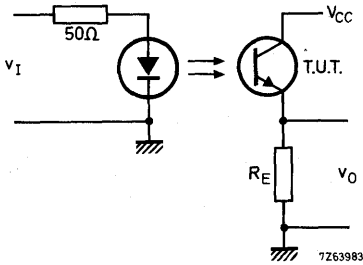

Fig. 2 Switching circuit.

Pulse generator:

$f = 500 \text{ Hz}$

$t_p = 20 \mu\text{s}$

$t_r = t_f = 20 \text{ ns}$

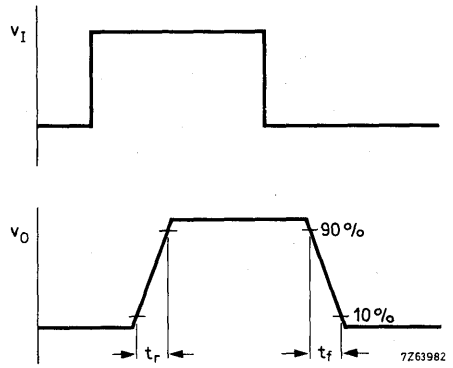

Fig. 3 Input and output switching waveforms.

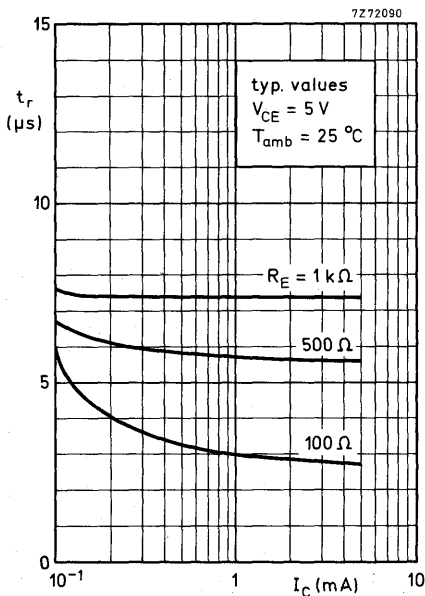

Fig. 4.

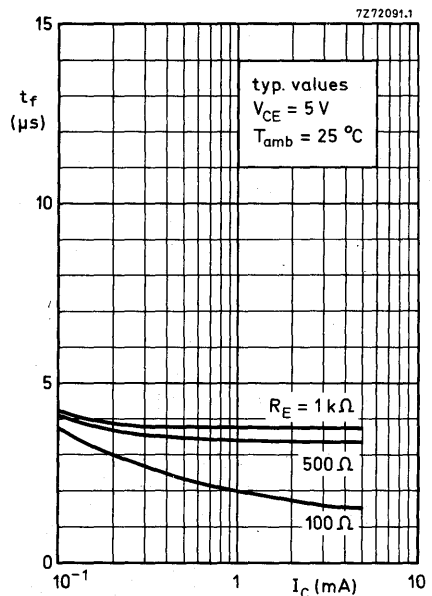

Fig. 5.

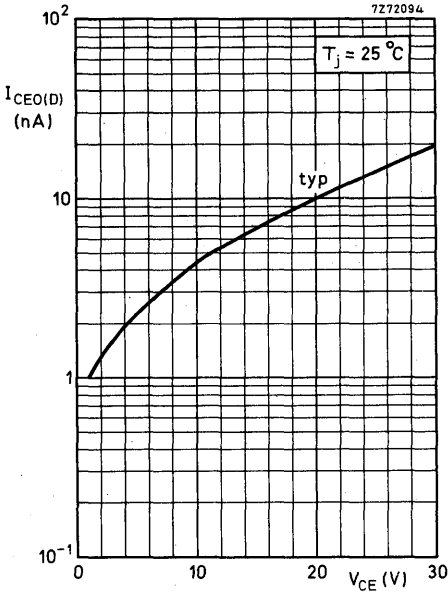

Fig. 6.

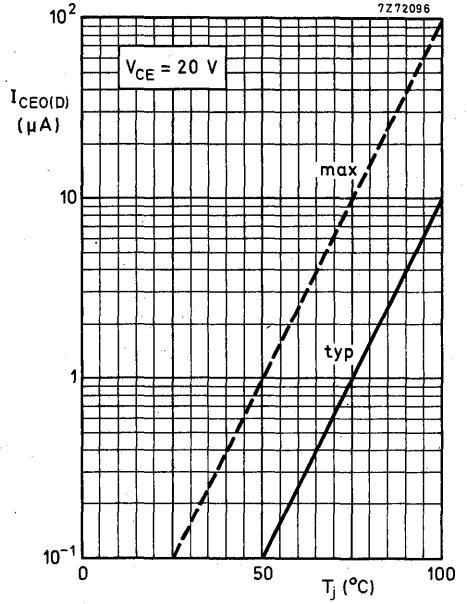

Fig. 7.

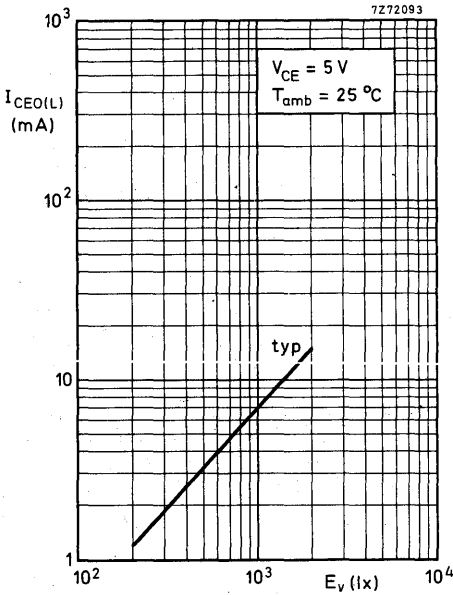

Fig. 8.

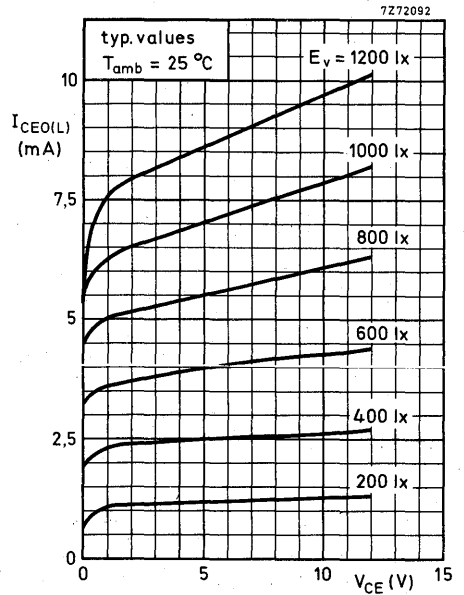

Fig. 9.

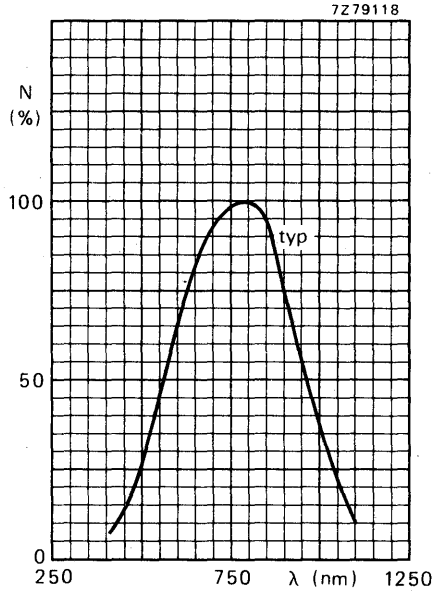

Fig. 10.

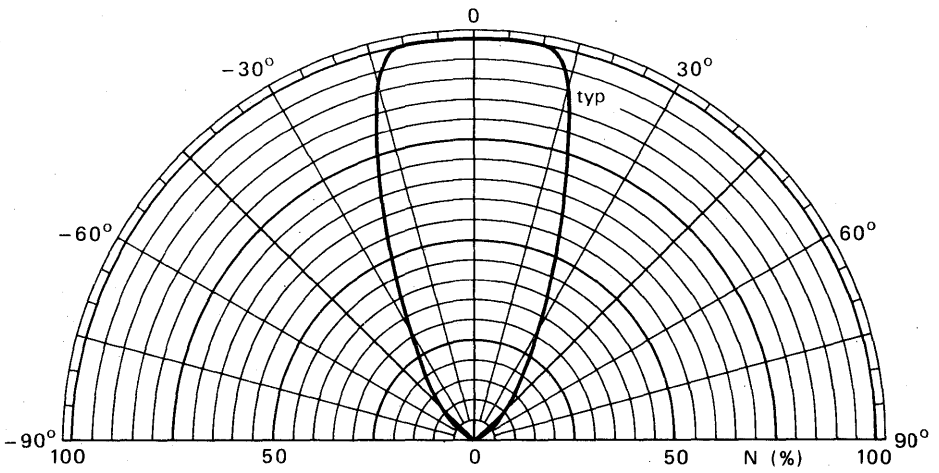
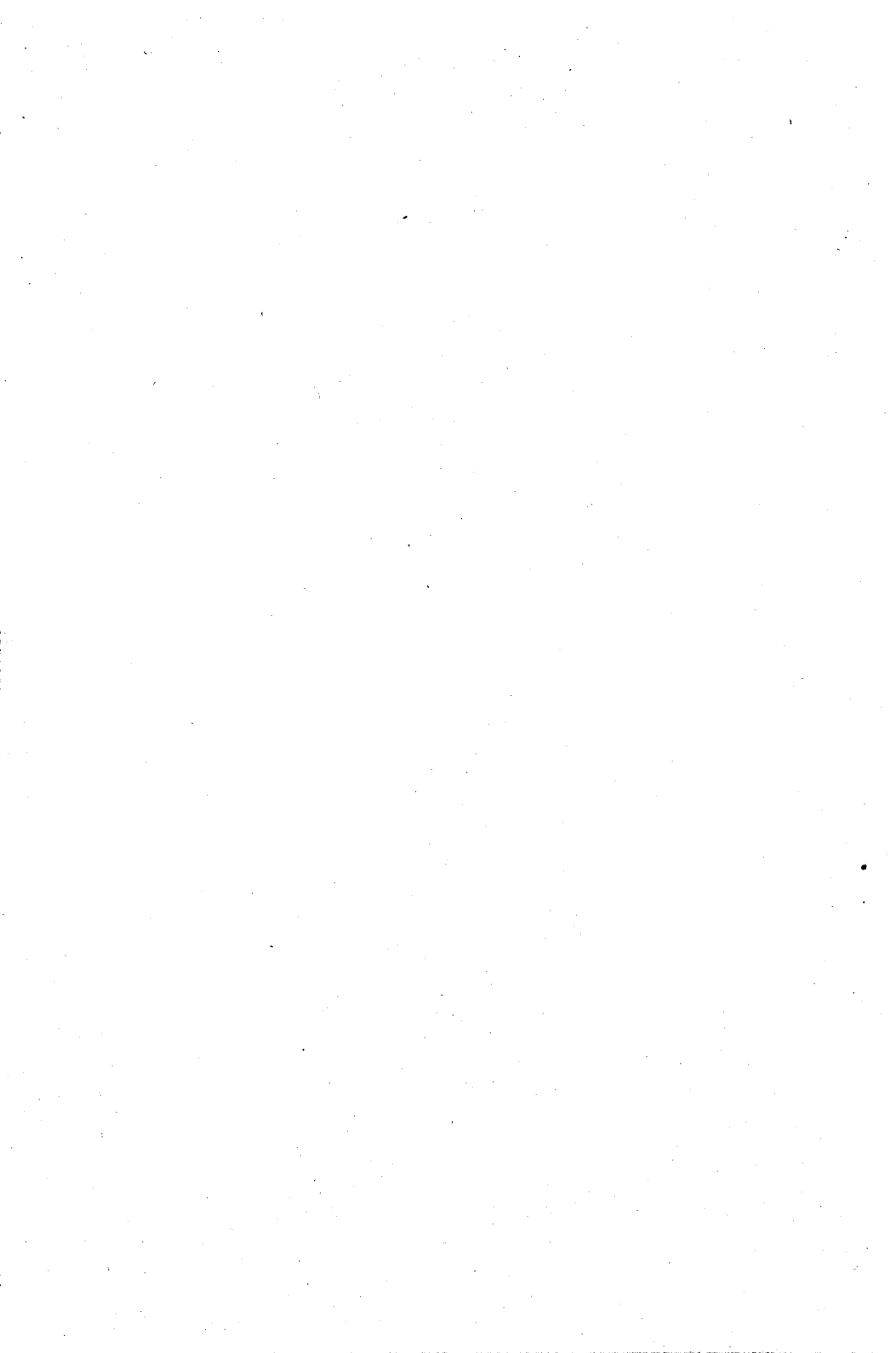

Fig. 11.

7Z79119

LIGHT EMITTING DIODES



GaAs LIGHT EMITTING DIODE

Gallium arsenide light emitting diode intended for optical coupling and encoding. It emits radiation in the near infrared when forward biased. The diode is provided with a flat glass window.

QUICK REFERENCE DATA

Continuous reverse voltage	V_R	max.	2 V
Forward current (d. c.)	I_F	max.	30 mA
Forward current (peak value) $t_p = 100 \mu s; \delta = 0, 1$	I_{FM}	max.	200 mA
Total power dissipation up to $T_{amb} = 95 \text{ }^\circ\text{C}$	P_{tot}	max.	50 mW
Total radiant power at $I_F = 20 \text{ mA}$	ϕ_e	> typ.	60 μW 100 μW
Radiant intensity (on-axis) at $I_F = 20 \text{ mA}$	I_e	typ.	64 $\mu\text{W}/\text{sr}$
Light rise time at $I_{F \text{ on}} = 20 \text{ mA}$	t_r	<	100 ns
Light fall time at $I_{F \text{ on}} = 20 \text{ mA}$	t_f	<	100 ns
Wavelength at peak emission	λ_{pk}	typ.	880 nm
Thermal resistance from junction to ambient	$R_{th \text{ j-a}}$	=	0,6 $^\circ\text{C}/\text{mW}$

MECHANICAL DATA

Dimensions in mm

TO-18, except for window

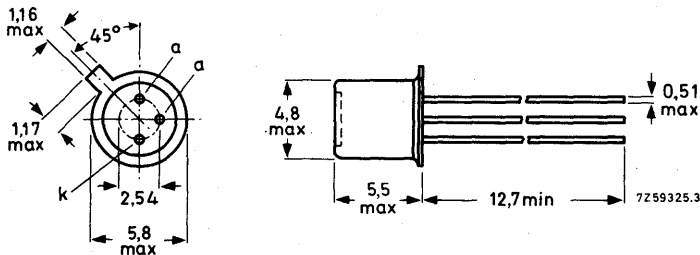

Max. lead diameter is guaranteed only for 12,7 mm

RATINGS Limiting values in accordance with the Absolute Maximum System (IEC 134)

Voltage

Continuous reverse voltage V_R max. 2 V

Current

Forward current (d. c.) I_F max. 30 mA

Forward current (peak value)
 $t_p = 100 \mu s; \delta = 0, 1$ I_{FM} max. 200 mA

Power dissipation

Total power dissipation up to $T_{amb} = 95 \text{ }^\circ\text{C}$ P_{tot} max. 50 mW

Temperature

Storage temperature T_{stg} -55 to +150 $^\circ\text{C}$

Operating junction temperature T_j max. 125 $^\circ\text{C}$

THERMAL RESISTANCE

From junction to ambient in free air $R_{th j-a} = 0,6 \text{ }^\circ\text{C/mW}$

From junction to case $R_{th j-c} = 0,22 \text{ }^\circ\text{C/mW}$

CHARACTERISTICS

$T_{amb} = 25 \text{ }^\circ\text{C}$ unless otherwise specified

Forward voltage at $I_F = 30 \text{ mA}$ V_F typ. 1,3 V
 < 1,6 V

$I_{FM} = 0,2 \text{ A}$ V_F typ. 1,5 V

Reverse current at $V_R = 2 \text{ V}$ I_R < 0,5 mA

Diode capacitance at $f = 1 \text{ MHz};$
 $V_R = 0$ C_d typ. 65 pF

CHARACTERISTICS (continued)

 $T_{amb} = 25\text{ }^{\circ}\text{C}$ unless otherwise specified

Radiant output power at $I_F = 20\text{ mA}$	ϕ_e	>	60	μW
		typ.	100	μW
$I_F = 20\text{ mA}; T_j = 100\text{ }^{\circ}\text{C}$	ϕ_e	typ.	50	μW
$I_F = 200\text{ mA}$ ¹⁾	ϕ_e	typ.	1, 16	mW
Radiant intensity (on-axis) at $I_F = 20\text{ mA}$	I_e	typ.	64	$\mu\text{W}/\text{sr}$
Radiance at $I_F = 20\text{ mA}$	L_e	typ.	1, 6	$\text{mW}/\text{mm}^2\text{sr}$
$I_F = 200\text{ mA}$ ¹⁾	L_e	typ.	15	$\text{mW}/\text{mm}^2\text{sr}$
Emissive area	A_e	typ.	0, 04	mm^2
Wavelength at peak emission	λ_{pk}	typ.	880	nm
Bandwidth at half height	$\Delta\lambda$	typ.	40	nm
Light rise time at $I_{Fon} = 20\text{ mA}$	t_r	typ.	30	ns
		<	100	ns
Light fall time at $I_{Fon} = 20\text{ mA}$	t_f	typ.	30	ns
		<	100	ns

¹⁾ $t_p = 100\text{ }\mu\text{s}; \delta = 0, 1.$

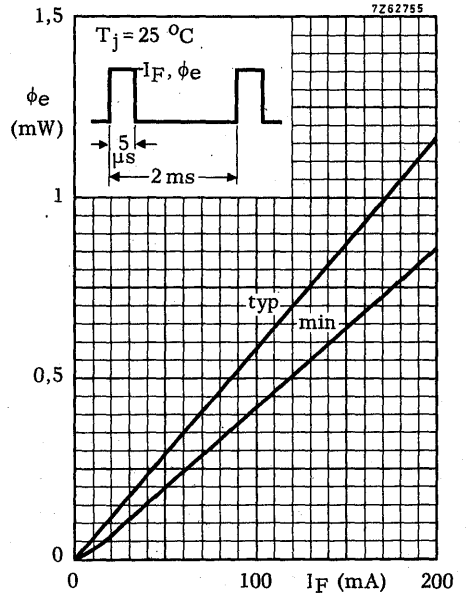
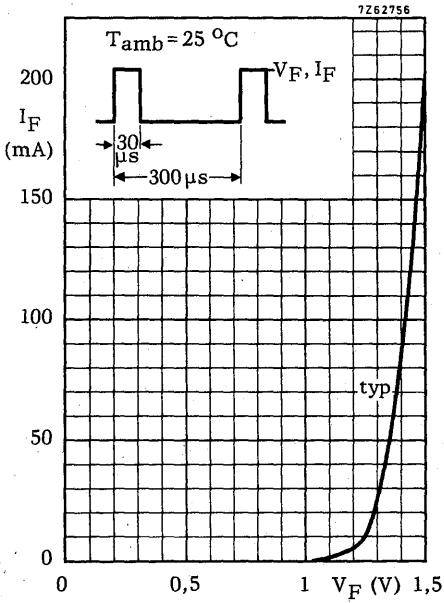
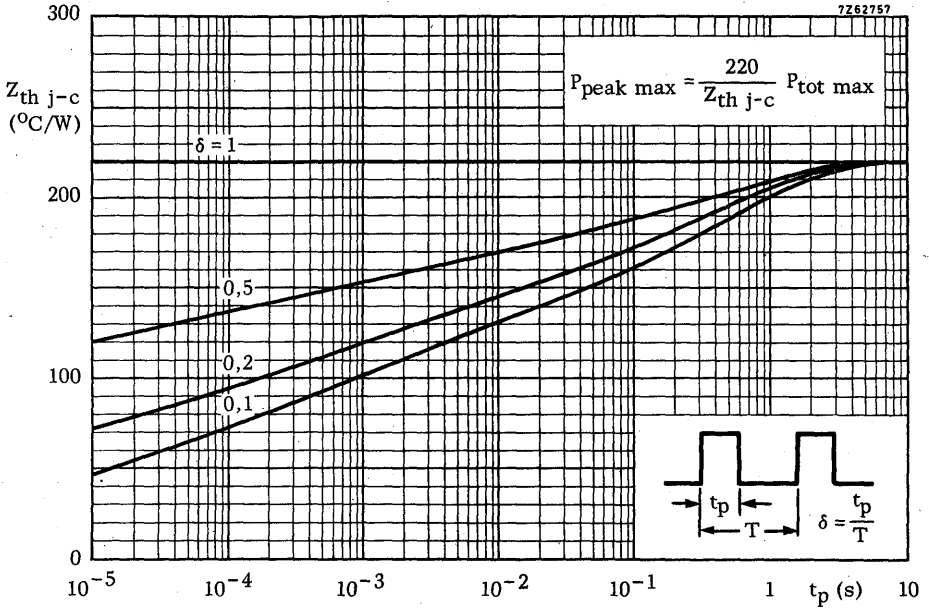

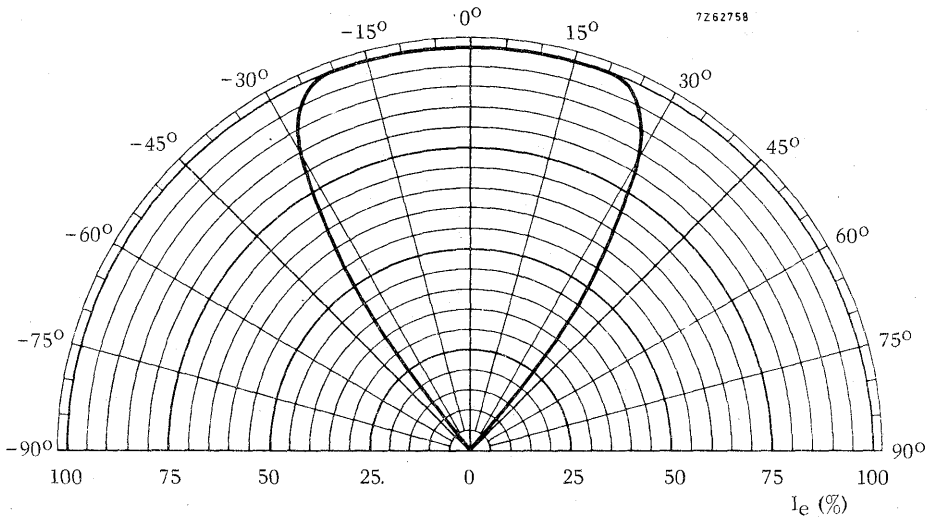
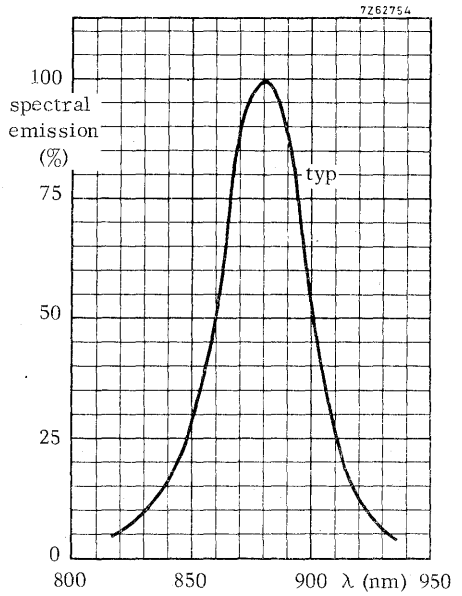
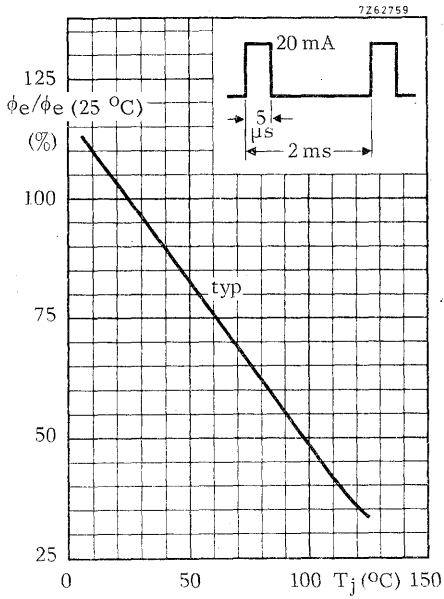

GALLIUM ARSENIDE LIGHT EMITTING DIODE

Gallium arsenide light emitting diode intended for optical coupling and encoding. It emits radiation in the near infrared when forward biased. Suitable for combination with photo-transistor BPX 25 or BPX 72.

QUICK REFERENCE DATA

Continuous reverse voltage	V_R	max.	2	V
Forward current (d. c.)	I_F	max.	30	mA
Forward current (peak value)	I_{FM}	max.	200	mA
Total power dissipation up to $T_{amb} = 95\text{ }^\circ\text{C}$	P_{tot}	max.	50	mW
Total radiant power at $I_F = 20\text{ mA}$	ϕ_e	typ.	50	μW
Radiant intensity (on-axis) at $I_F = 20\text{ mA}$	I_e	typ.	1,25	mW/sr
Light rise time at $I_{Fon} = 20\text{ mA}$	t_r	<	100	ns
Light fall time at $I_{Fon} = 20\text{ mA}$	t_f	<	100	ns
Wavelength at peak emission	λ_{pk}	typ.	880	nm
Thermal resistance from junction to ambient	$R_{th\ j-a}$	=	0,6	$^\circ\text{C}/\text{mW}$

MECHANICAL DATA

Dimensions in mm

TO-18, except for lens

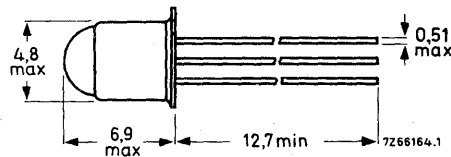
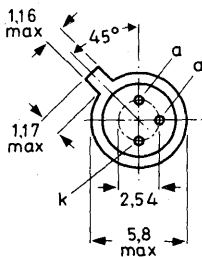

CQY11C

RATINGS Limiting values in accordance with the Absolute Maximum System (IEC 134)

Voltage

Continuous reverse voltage V_R max. 2 V

Current

Forward current (d. c.) I_F max. 30 mA

Forward current (peak value)
 $t_p = 100 \mu s; \delta = 0, 1$

I_{FM} max. 200 mA

Power dissipation

Total power dissipation up to
 $T_{amb} = 95 \text{ }^\circ\text{C}$

P_{tot} max. 50 mW

Temperature

Storage temperature T_{stg} -55 to +150 $^\circ\text{C}$

Junction temperature T_j max. 125 $^\circ\text{C}$

THERMAL RESISTANCE

From junction to ambient in free air $R_{th j-a} = 0,6 \text{ }^\circ\text{C/mW}$

From junction to case $R_{th j-c} = 0,22 \text{ }^\circ\text{C/mW}$

CHARACTERISTICS

$T_{amb} = 25 \text{ }^\circ\text{C}$ unless otherwise specified

Forward voltage

$I_F = 30 \text{ mA}$

V_F typ. 1,3 V
< 1,6 V

$I_{FM} = 200 \text{ mA}$

V_F typ. 1,5 V

Reverse current

$V_R = 2 \text{ V}$

I_R < 0,5 mA

Diode capacitance

$V_R = 0; f = 20 \text{ MHz}$

C_d typ. 25 pF

Total radiant power

$I_F = 20 \text{ mA}$

ϕ_e typ. 50 μW

Radiant intensity (on-axis)

$I_F = 20 \text{ mA}$

I_e typ. 1,25 mW/sr

CHARACTERISTICS (continued)

Mean irradiance

on a receiving area with $D = 2$ mm at a distance $a = 10$ mm and at $I_{F} = 20$ mA, measured as below

E_e	>	0,28	mW/cm^2
	typ.	0,50	mW/cm^2 ¹⁾

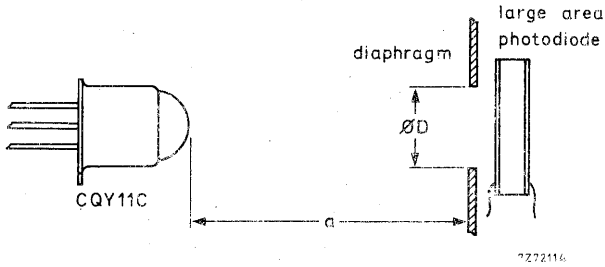

Fig. 1

Decrease of radiant power with temperature

$\frac{\Delta\phi_e}{\Delta T_j}$	typ.	0,7	%/°C
-----------------------------------	------	-----	------

Cross section of the radiant beam

between 0 to 10 mm from the lens

A_{beam}	typ.	7	mm^2
-------------------	------	---	---------------

Angle between optical and mechanical axis

6°

Wavelength at peak emission

λ_{pk}	typ.	880	nm
-----------------------	------	-----	----

Bandwidth at half height

$B_{50\%}$	typ.	40	nm
------------	------	----	----

Light rise time at $I_{Fon} = 20$ mA

t_r	typ.	30	ns
	<	100	ns

Light fall time at $I_{Fon} = 20$ mA

t_f	typ.	30	ns
	<	100	ns

¹⁾ This corresponds typically with $I_{CEO(L)} = 0,4$ mA in a phototransistor BPX25 and with 200 μA in a phototransistor BPX72.

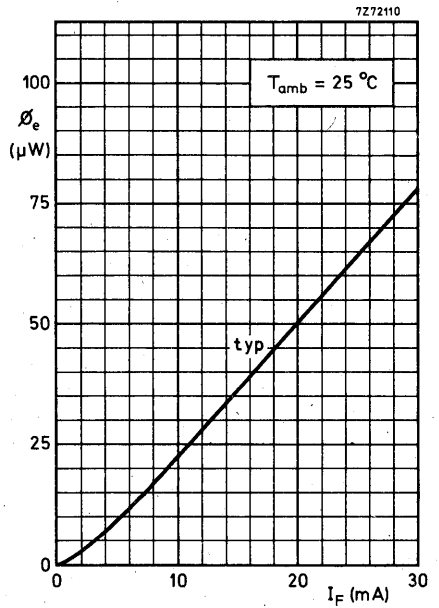
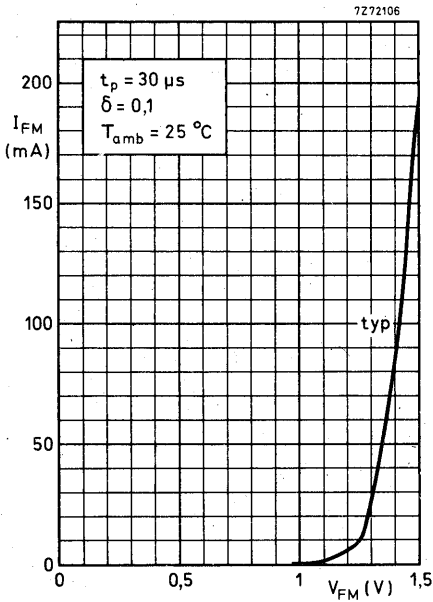
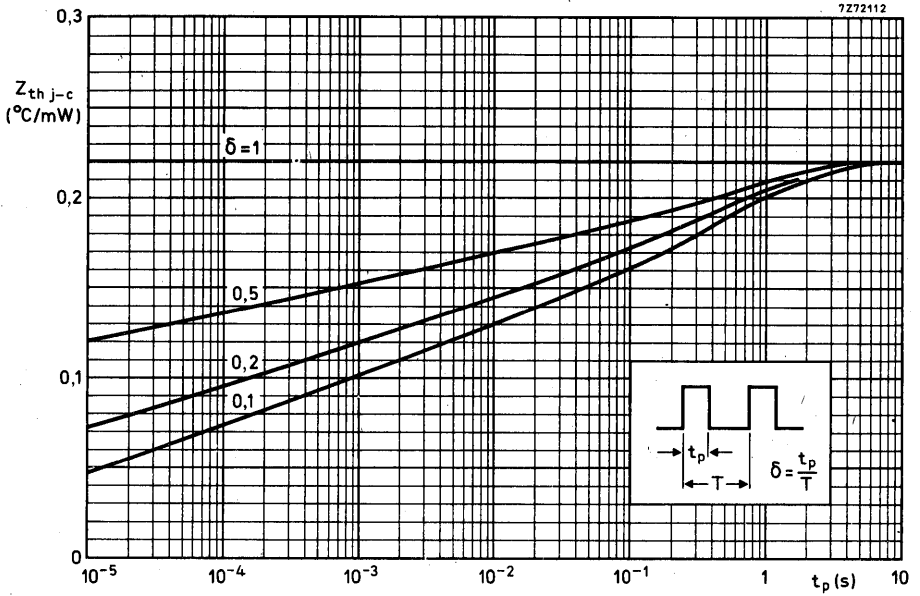

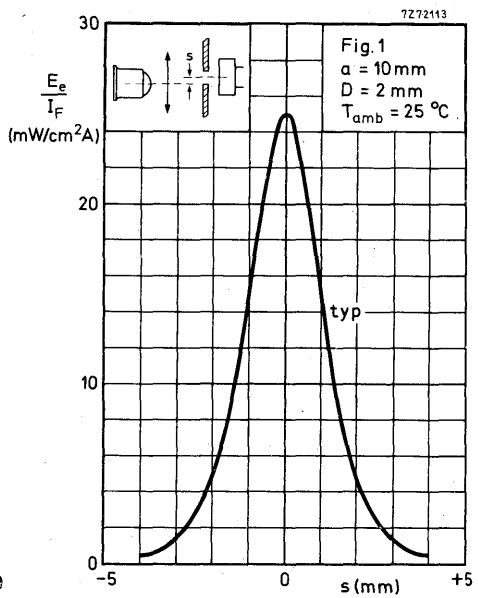
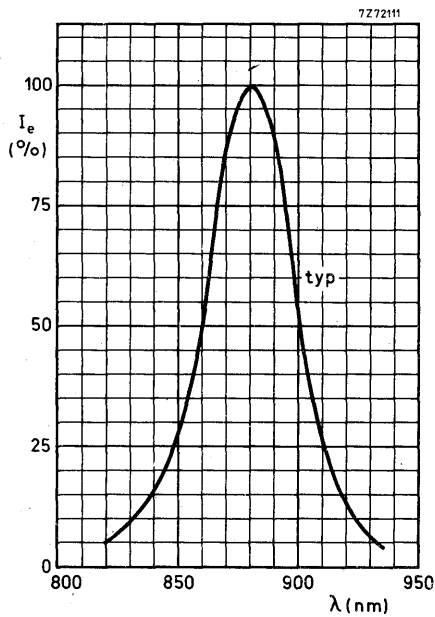
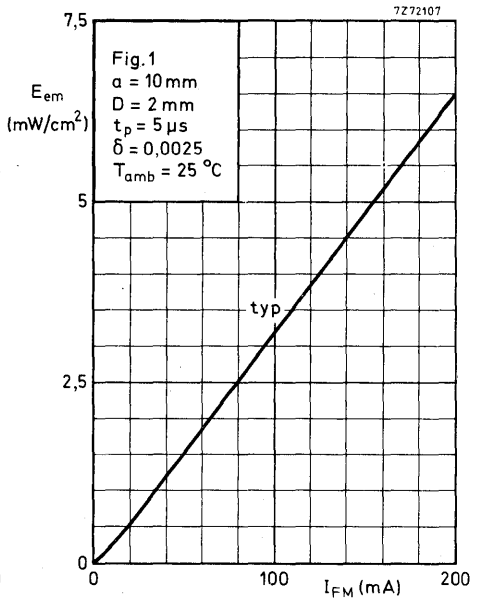
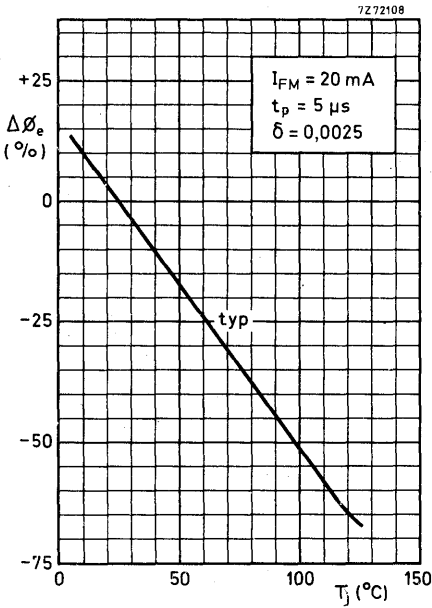

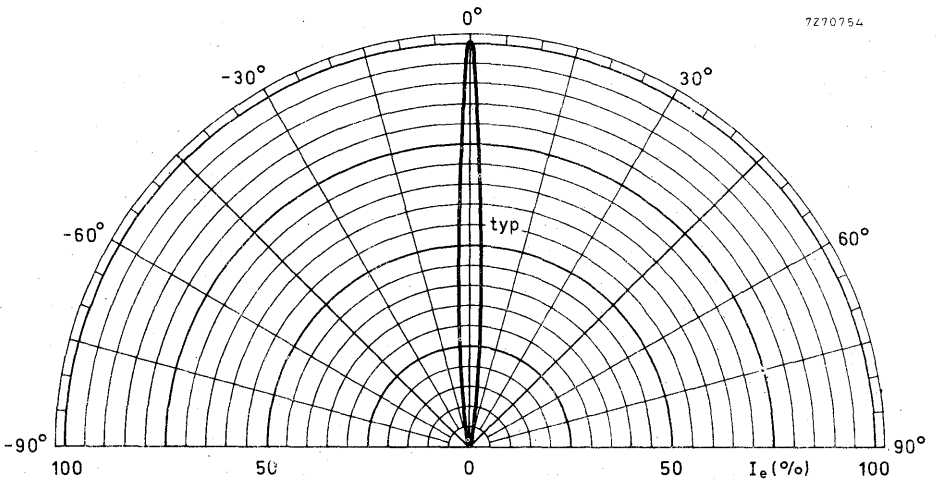
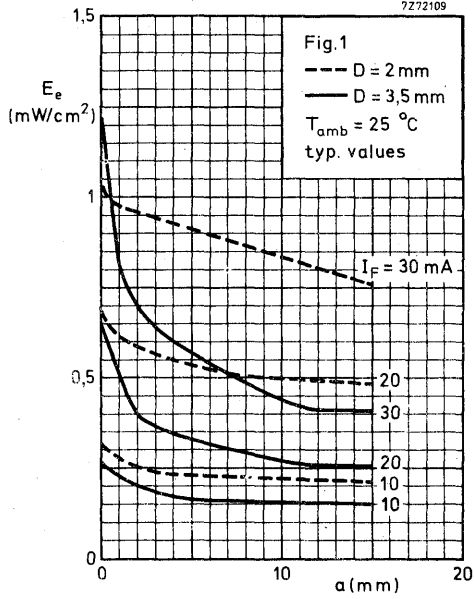

GaAsP RED LIGHT EMITTING DIODE

Gallium arsenide phosphide light emitting diode which emits visible red light when forward biased. The envelope is of light-diffusing red plastic, and has been designed for high-density arrays.

QUICK REFERENCE DATA					
Continuous reverse voltage	V_R	max.	3	V	
Forward current (d. c.)	I_F	max.	50	mA	
Total power dissipation up to $T_{amb} = 37,5 \text{ }^\circ\text{C}$	P_{tot}	max.	100	mW	
Luminous intensity (on-axis)					
$I_F = 20 \text{ mA}$	CQY24A	I_V	>	0,3	mcd
	CQY24A-I	I_V		0,7 to 1,6	mcd
	CQY24A-II	I_V		1 to 2,2	mcd
	CQY24A-III	I_V	>	1,6	mcd
Wavelength at peak emission	λ_{pk}	typ.	650	nm	
Beamwidth between half-intensity directions	$\alpha_{50\%}$	typ.	70°		
Thermal resistance from junction to ambient	$R_{th \text{ j-a}}$	=	0,625	$^\circ\text{C}/\text{mW}$	

MECHANICAL DATA

Dimensions in mm

Fig. 1 SOD-39C.

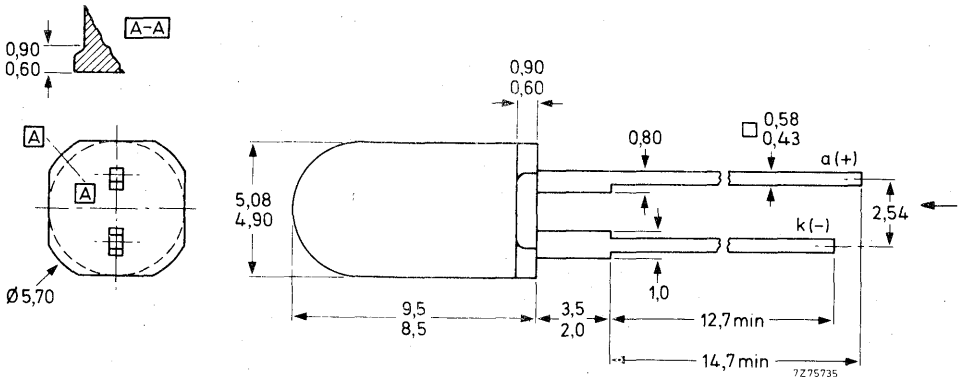

Accessories for panel mounting (panel thickness < 4 mm)

Plastic clip and ring, black: type RTC757
colourless: type RTC758

Hole diameter 6,4 mm for panel thickness < 3 mm
6,5 mm for panel thickness > 3 mm

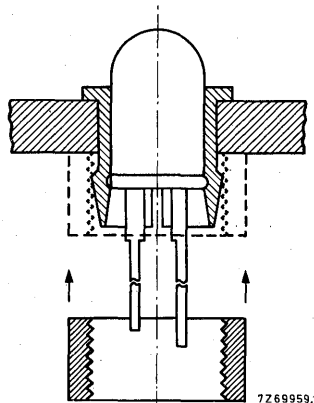
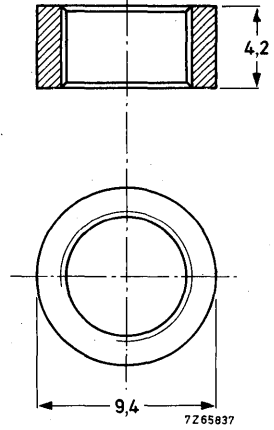
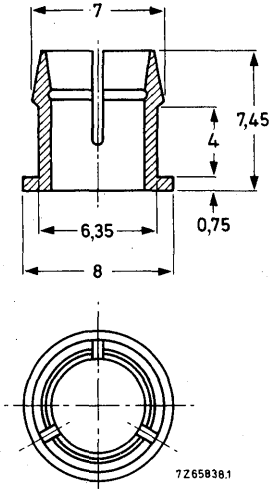

RATINGS Limiting values in accordance with the Absolute Maximum System (IEC 134)

Voltage

Continuous reverse voltage V_R max. 3 V

Current

Forward current (d.c.) I_F max. 50 mA

Forward current (peak value)
 $t_p = 1 \mu\text{s}; f = 300 \text{ Hz}$ I_{FM} max. 1 A

Temperature

Storage temperature T_{stg} -55 to +100 °C

Junction temperature T_j max. 100 °C

Lead soldering temperature
 up to seating plane; $t_{sld} < 10 \text{ s}$ T_{sld} max. 260 °C

Power dissipation

Total power dissipation up to $T_{amb} = 37,5 \text{ °C}$ P_{tot} max. 100 mW

THERMAL RESISTANCE

From junction to ambient,
 in free air $R_{th j-a} = 0,625 \text{ °C/mW}$

mounted on printed-circuit board $R_{th j-a} = 0,500 \text{ °C/mW}$

CQY24A

CHARACTERISTICS

$T_j = 25\text{ }^\circ\text{C}$ unless otherwise specified

Forward voltage

$I_F = 20\text{ mA}$

V_F typ. 1,7 V
< 2 V

Negative temperature coefficient of V_F

$I_F = 20\text{ mA}$

$\frac{-\Delta V_F}{\Delta T_j}$ typ. 1,6 mV/ $^\circ\text{C}$

$I_F = 2\text{ mA}$

$\frac{-\Delta V_F}{\Delta T_j}$ typ. 2 mV/ $^\circ\text{C}$

Reverse current

$V_R = 3\text{ V}$

I_R < 100 μA

\rightarrow Luminous intensity (on-axis)

$I_F = 20\text{ mA}$

CQY24A	I_v	>	0,3	mcd
CQY24A-I	I_v		0,7 to 1,6	mcd
CQY24A-II	I_v		1 to 2,2	mcd
CQY24A-III	I_v	>	1,6	mcd

Diode capacitance

$V_R = 0$; $f = 1\text{ MHz}$

C_d typ. 60 pF

Wavelength at peak emission

λ_{pk} typ. 650 nm

Bandwidth at half height

$B_{50\%}$ typ. 20 nm

Beamwidth between half-intensity directions

$\alpha_{50\%}$ typ. 70°

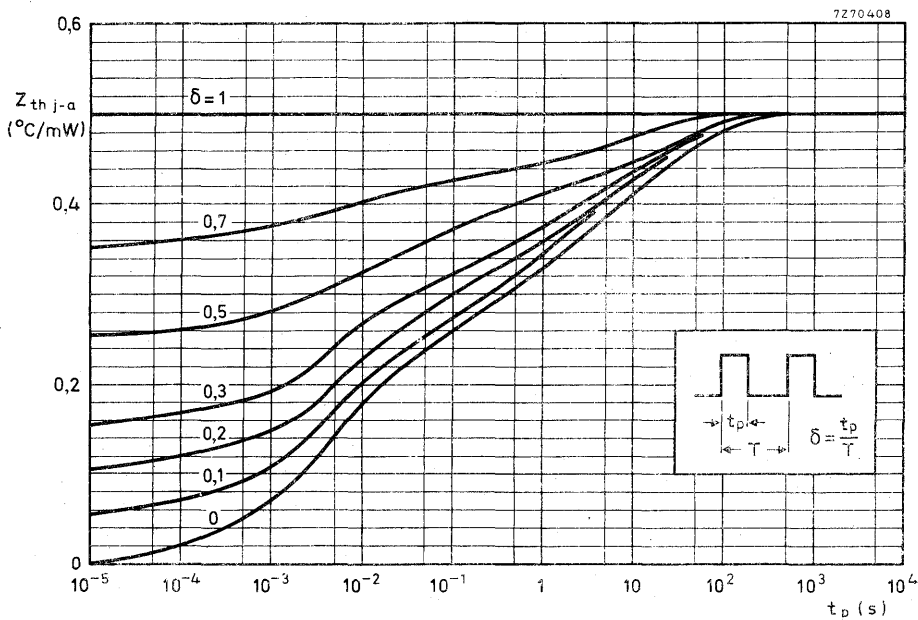
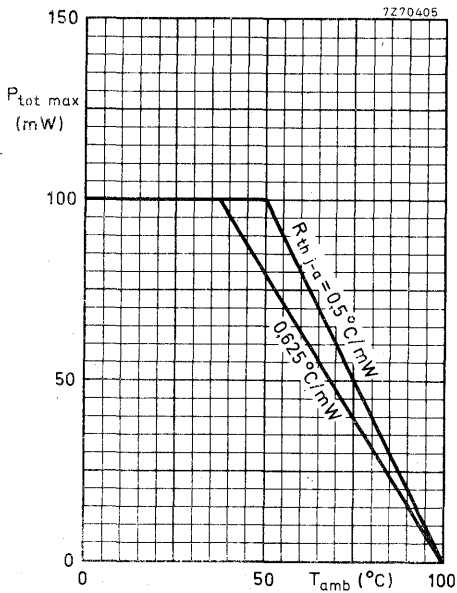

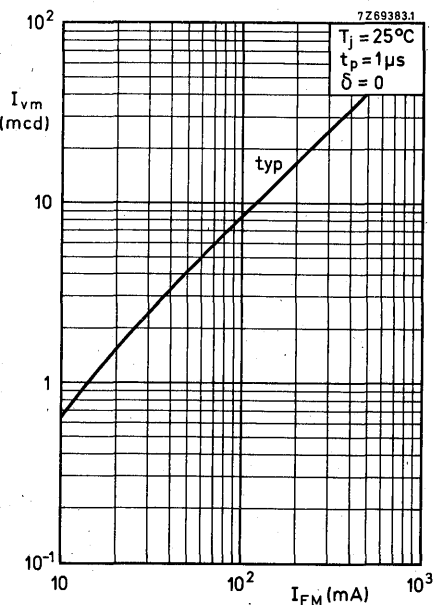
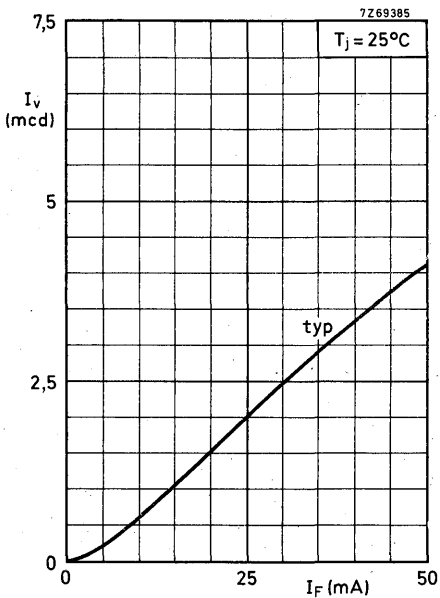
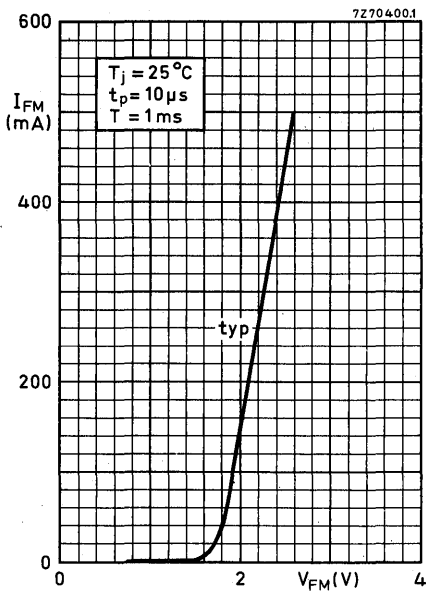
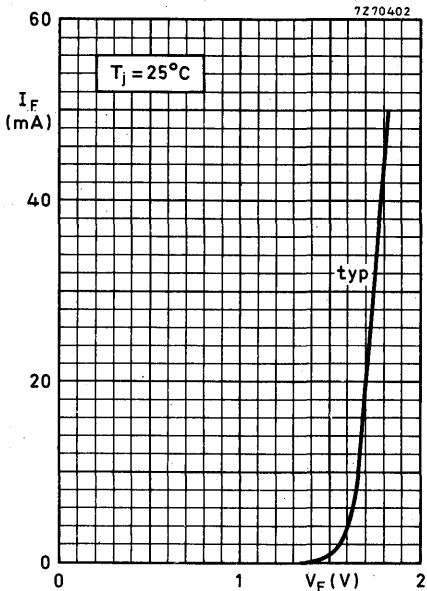

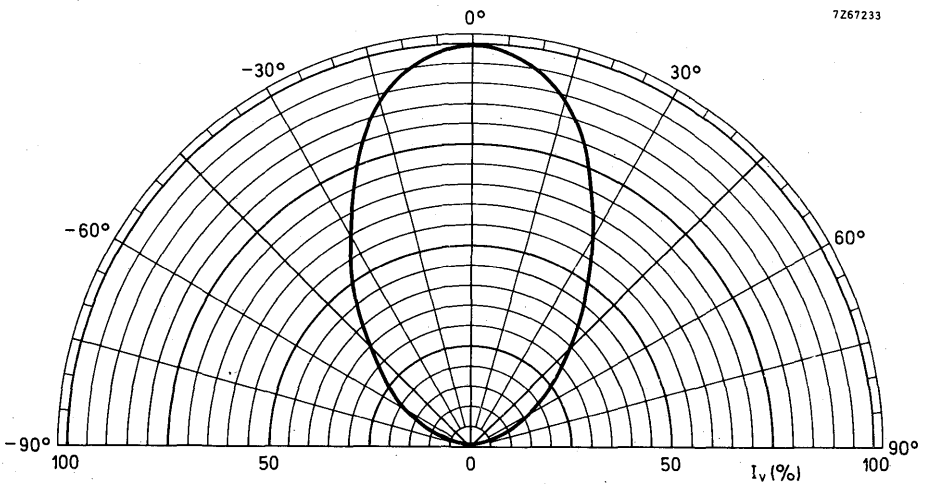
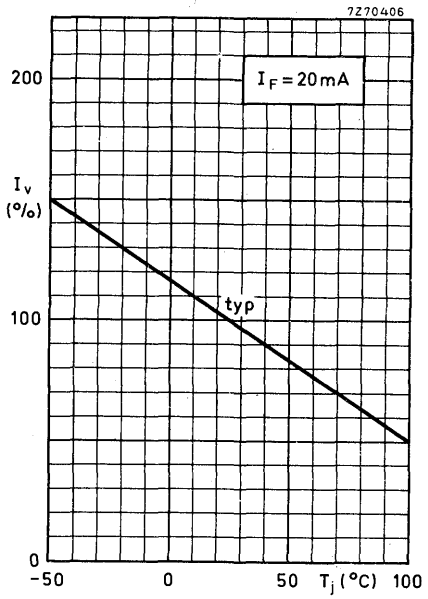
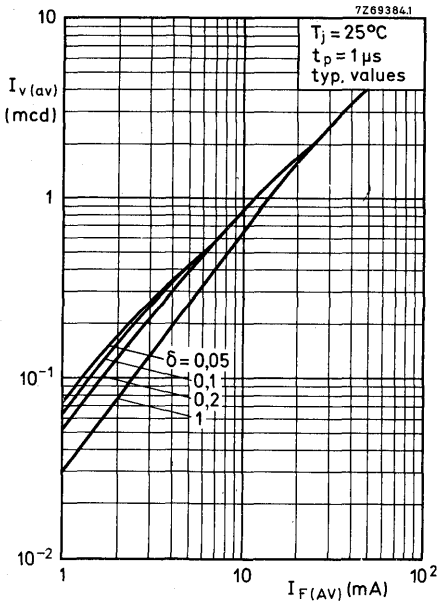

GaAsP RED LIGHT EMITTING DIODES

Gallium arsenide phosphide light emitting diodes which emit visible red light when forward biased.

The envelopes are of clear, non-diffusing resin: red for CQY46A, colourless for CQY47A, both showing a clearly defined point of light.

CQY46A has better contrast, CQY47A shows no red reflections from sunlight or incandescent light sources.

QUICK REFERENCE DATA

Continuous reverse voltage	V_R	max.	3 V
Forward current (d.c.)	I_F	max.	50 mA
Total power dissipation up to $T_{amb} = 37,5\text{ }^\circ\text{C}$	P_{tot}	max.	100 mW
Junction temperature	T_j	max.	100 $^\circ\text{C}$
Thermal resistance from junction to ambient	R_{thj-a}	=	0,625 $^\circ\text{C}/\text{mW}$
Luminous intensity (on-axis) at $I_F = 20\text{ mA}$	I_v	>	0,4 mcd
Angle between half-intensity directions	$\alpha_{50\%}$	typ.	100 $^\circ$
Wavelength at peak emission	λ_{pk}	typ.	650 nm

MECHANICAL DATA

Dimensions in mm

Fig. 1 SOD-39D

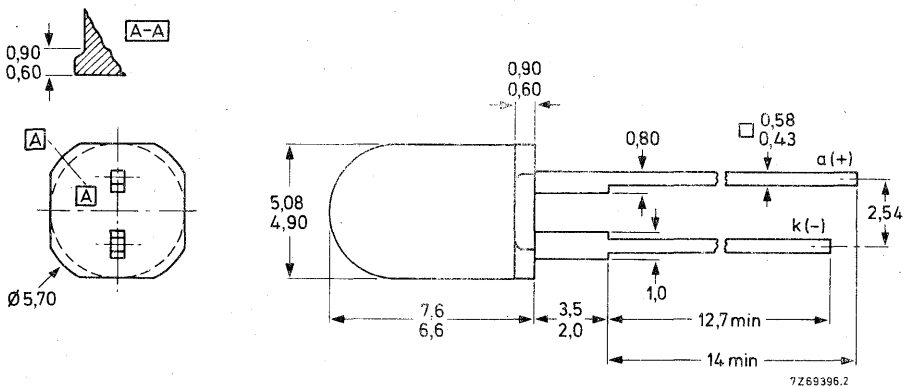

Accessories for panel mounting (panel thickness < 4 mm)

Plastic clip and ring,

black: type RTC757

colourless: type RTC758

Hole diameter

6,4 mm for panel thickness < 3 mm

6,5 mm for panel thickness > 3 mm

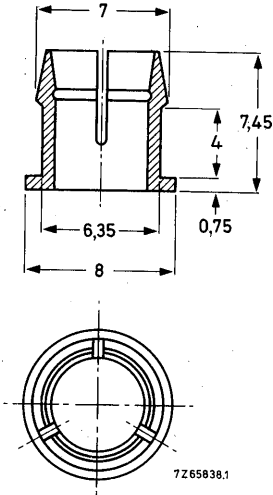

Fig. 2.

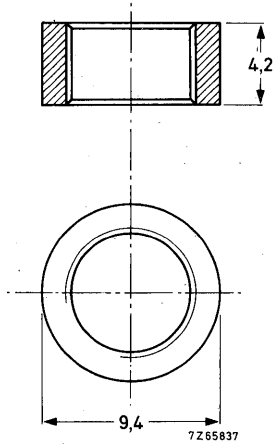

Fig. 3.

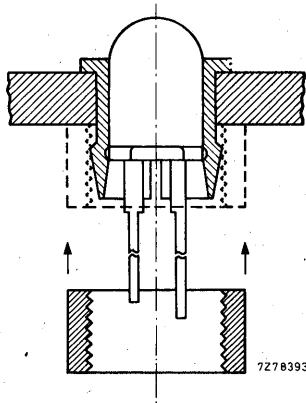

Fig. 4.

RATINGS

Limiting values in accordance with the Absolute Maximum System (IEC 134)

Continuous reverse voltage	V_R	max.	3 V
Forward current (d.c.)	I_F	max.	50 mA
Forward current (peak value) $t_p = 1 \mu s; \delta = 0,0003$	I_{FM}	max.	1000 mA
Power dissipation up to $T_{amb} = 37,5 \text{ }^\circ\text{C}$	P_{tot}	max.	100 mW
Storage temperature	T_{stg}		-55 to +100 $^\circ\text{C}$
Junction temperature	T_j	max.	100 $^\circ\text{C}$
Lead soldering temperature up to the seating plane; $t_{sld} < 10 \text{ s}$	T_{sld}	max.	260 $^\circ\text{C}$

THERMAL RESISTANCE

From junction to ambient	R_{thj-a}	=	0,625 $^\circ\text{C}/\text{mW}$
From junction to ambient device mounted on a printed-circuit board *	R_{thj-a}	=	0,5 $^\circ\text{C}/\text{mW}$

CHARACTERISTICS

 $T_j = 25 \text{ }^\circ\text{C}$ unless otherwise specified

Forward voltage $I_F = 20 \text{ mA}$	V_F	typ. <	1,7 V 2,0 V
Reverse current $V_R = 3 \text{ V}$	I_R	<	100 μA
Diode capacitance $V_R = 0; f = 1 \text{ MHz}$	C_d	typ.	60 pF
Luminous intensity (on-axis) $I_F = 20 \text{ mA}; T_{amb} = 25 \text{ }^\circ\text{C}$	I_v	> typ.	0,4 mcd 1,3 mcd
Wavelength at peak emission	λ_{pk}	typ.	650 nm
Beamwidth between half-intensity directions	$\alpha_{50\%}$	typ.	100 $^\circ$

* With copper island rings of 0,8 mm and 1,3 mm diameters on both sides of 1,6 mm glass-epoxy printed-circuit board; thickness of copper 35 μm .

7277703

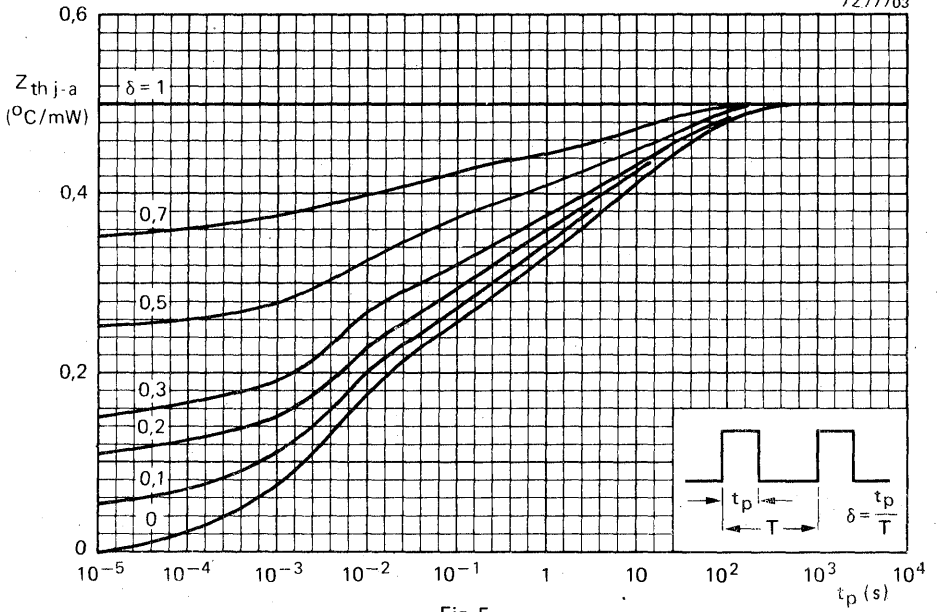

Fig. 5.

7277697

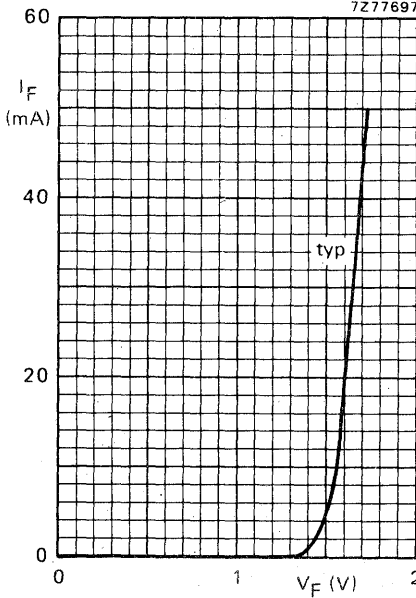

Fig. 6 $T_j = 25^{\circ}\text{C}$.

7277695

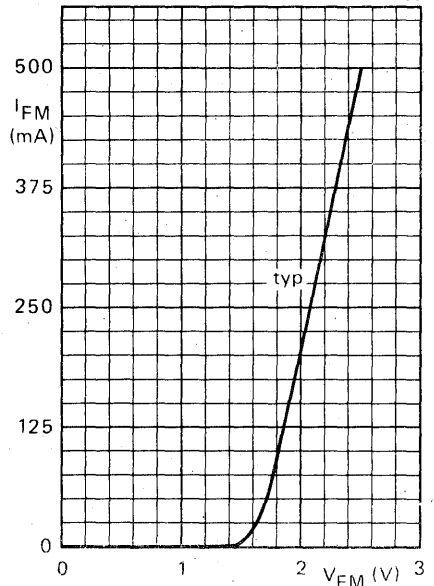

Fig. 7 $T_j = 25^{\circ}\text{C}$; $t_p = 10 \mu\text{s}$; $T = 1 \text{ ms}$.

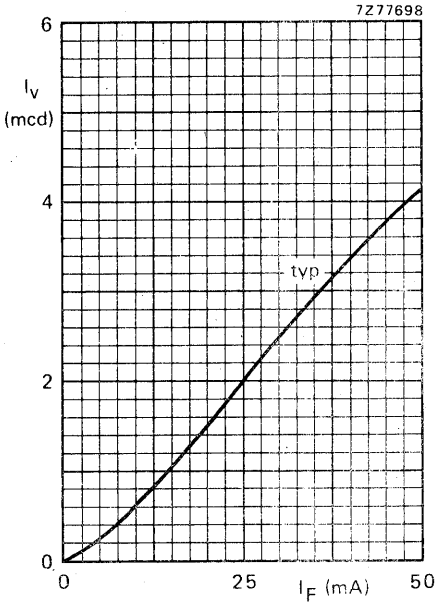

Fig. 8 $T_j = 25\text{ }^\circ\text{C}$.

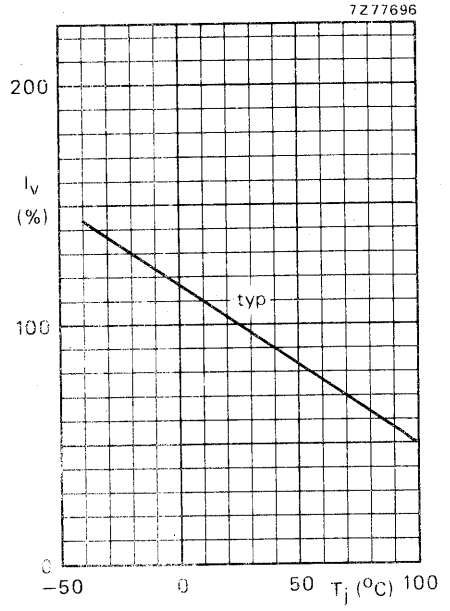

Fig. 9 $I_F = 20\text{ mA}$.

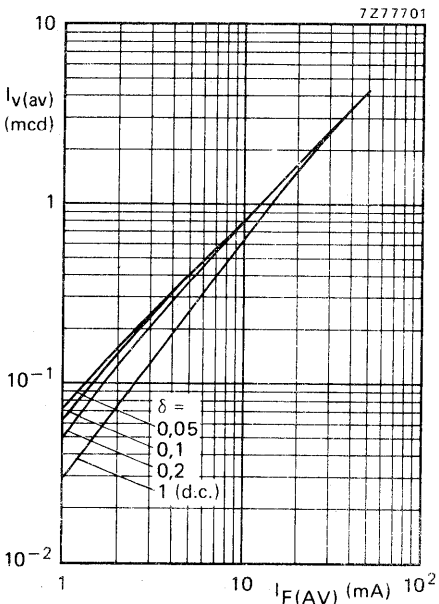

Fig. 10 Typical values; $T_j = 25\text{ }^\circ\text{C}$; $t_{av} = T$.

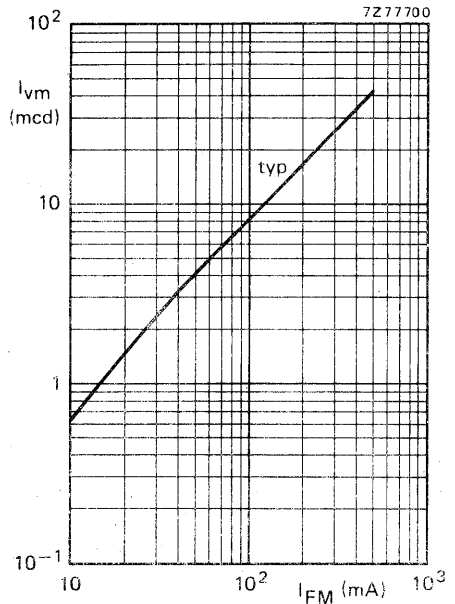

Fig. 11 $T_j = 25\text{ }^\circ\text{C}$; $t_p = 1\text{ }\mu\text{s}$; $\delta = 0$.

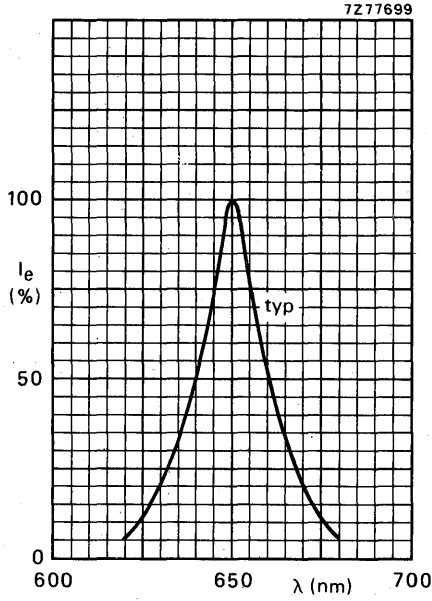

Fig. 12.

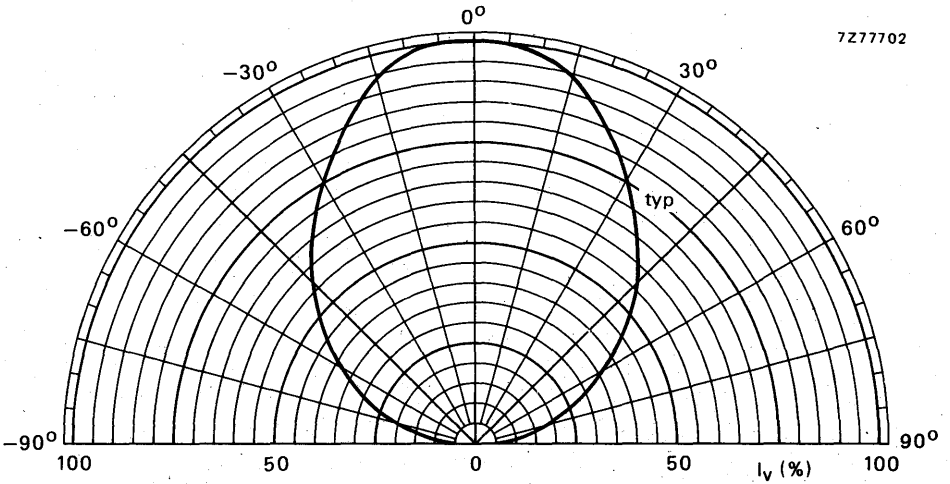

Fig. 13.

GaAs LIGHT EMITTING DIODES

Epitaxial gallium arsenide light emitting diodes intended for optical coupling and encoding. They emit radiation in the near infrared when forward biased. Envelopes like TO-18. Suitable for combination with phototransistors BPX25 and BPX72.

QUICK REFERENCE DATA

Continuous reverse voltage	V_R	max.	2	V
Forward current (d. c.)	I_F	max.	100	mA
Total power dissipation up to $T_{amb} = 25^\circ C$	P_{tot}	max.	150	mW
Radiant intensity (on-axis) at $I_F = 50$ mA	CQY49B	I_e	>	0,3 mW/sr
	CQY49C	I_e	>	3 mW/sr
Wavelength at peak emission	λ_{pk}	typ.	930	nm
Thermal resistance from junction to ambient	$R_{th j-a}$	=	0,665	$^\circ C/mW$

MECHANICAL DATA

Dimensions in mm

CQY49B : TO-18 except for window

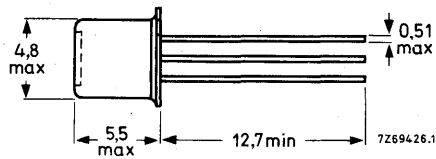
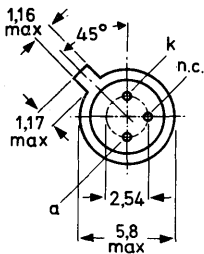

CQY49C : TO-18 except for lens

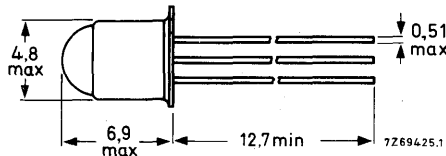
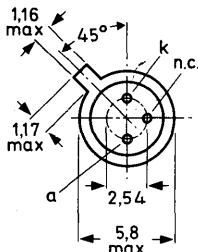

RATINGS Limiting values in accordance with the Absolute Maximum System (IEC 134)

Voltage

Continuous reverse voltage V_R max. 2 V

Current

Forward current (d. c.) I_F max. 100 mA

Forward current (peak value)
 $t_p < 10 \mu s; \delta < 0,01$ I_{FM} max. 1 A

Power dissipation

Total power dissipation up to $T_{amb} = 25 \text{ }^\circ\text{C}$ P_{tot} max. 150 mW

Temperature

Storage temperature T_{stg} -40 to +100 $^\circ\text{C}$

Operating junction temperature T_j max. 125 $^\circ\text{C}$

Lead soldering temperature
 $> 1,5 \text{ mm}$ from the body; $t_{sld} < 10 \text{ s}$ T_{sld} max. 260 $^\circ\text{C}$

THERMAL RESISTANCE

From junction to ambient in free air $R_{th j-a} = 0,665 \text{ }^\circ\text{C/mW}$

From junction to case $R_{th j-c} = 0,3 \text{ }^\circ\text{C/mW}$

CHARACTERISTICS

$T_j = 25^\circ\text{C}$ unless otherwise specified

		CQY49B		CQY49C	
		typ.	max.	typ.	max.
<u>Forward voltage</u> at $I_F = 50\text{ mA}$	V_F	typ.	1.3	typ.	1.3
		<	1.5	<	1.5
<u>Reverse current</u> at $V_R = 2\text{ V}$	I_R	<	100	<	100
<u>Diode capacitance</u>	C_d	typ.	35	typ.	35
$V_R = 0; f = 1\text{ MHz}$					
<u>Radiant intensity</u> (on-axis) at $I_F = 50\text{ mA}$	I_e	>	0.3	>	3
		typ.	0.5	typ.	5
					mW/sr
<u>Wavelength</u> at peak emission	λ_{pk}	typ.	920	typ.	920
					nm
<u>Bandwidth</u> at half height	$\Delta 50\%$	typ.	50	typ.	50
					nm
<u>Beamwidth</u> between half-intensity directions	$\alpha 50\%$	typ.	80°	typ.	15°
<u>Angle</u> between optical and mechanical axis		typ.	--	typ.	6°
<u>Switching times</u>					
$I_{Fon} = 50\text{ mA}; t_p = 2\ \mu\text{s}; f = 45\text{ kHz}$					
Light rise time	t_r	typ.	600	typ.	ns
Light fall time	t_f	typ.	350	typ.	ns

**CQY49B
CQY49C**

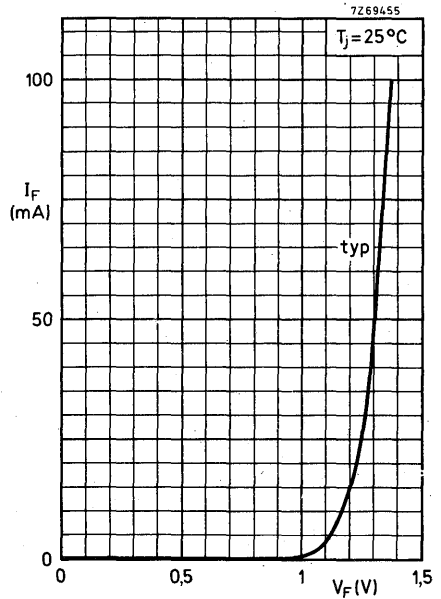
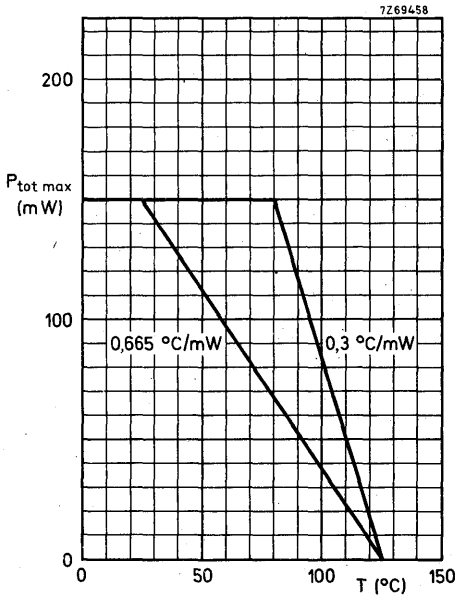
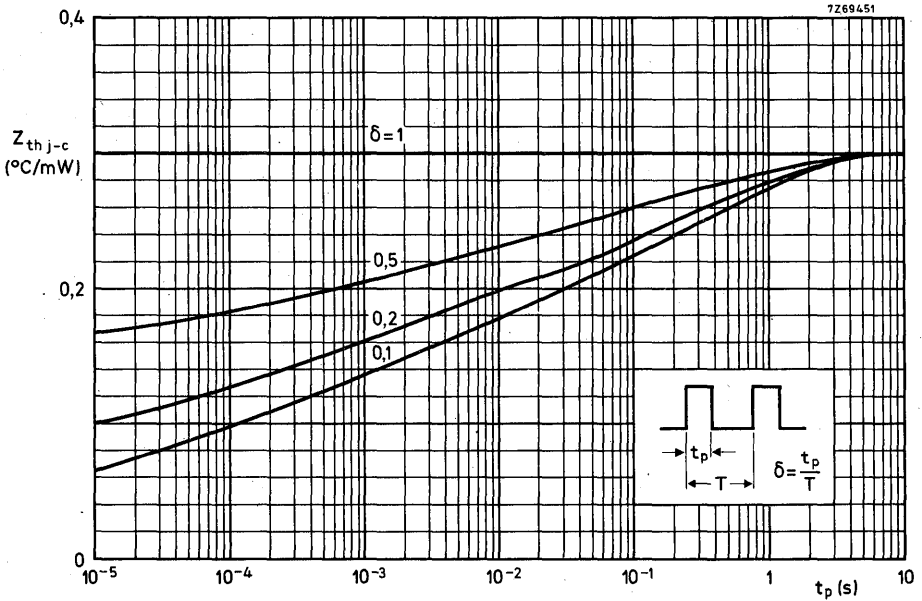

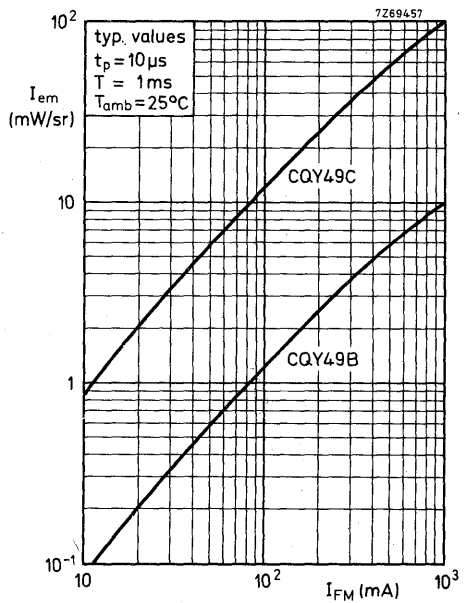
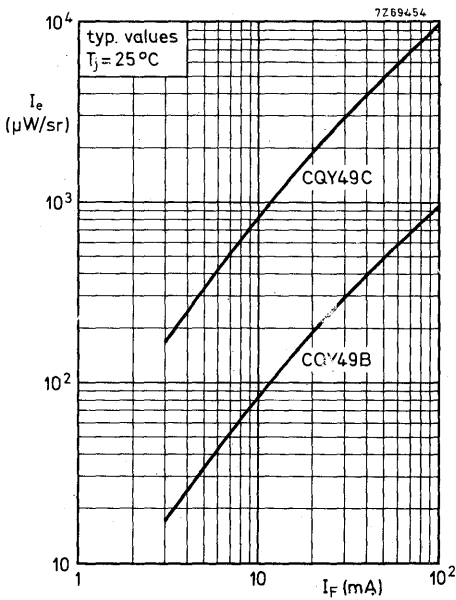
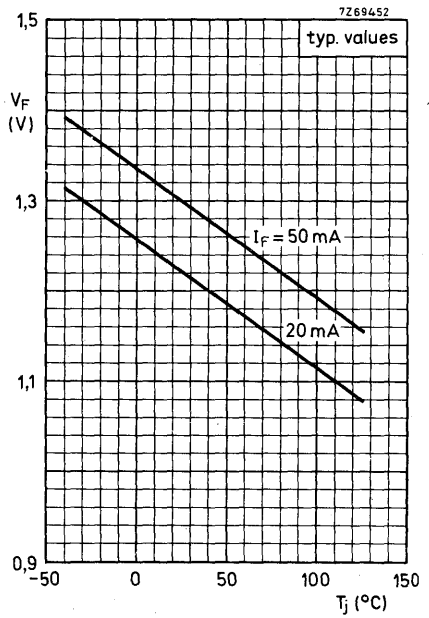
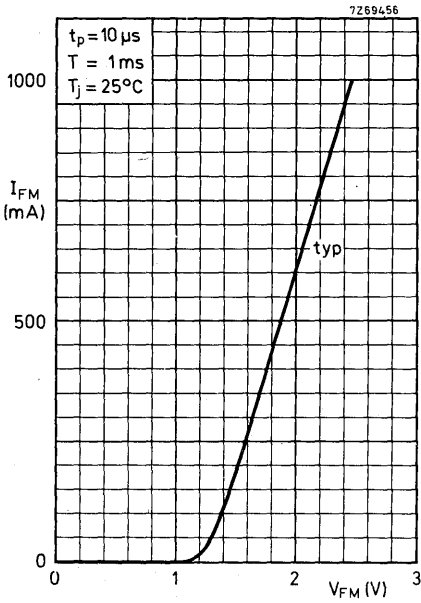

CQY49B
CQY49C

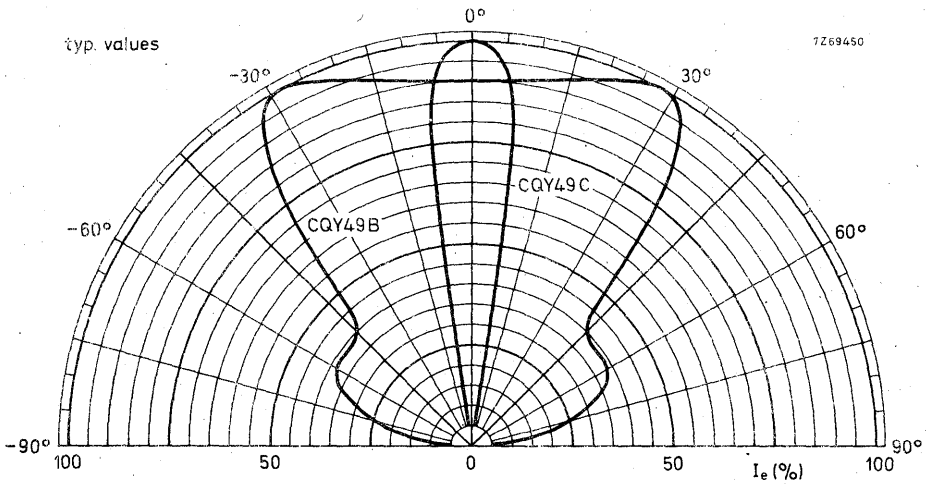
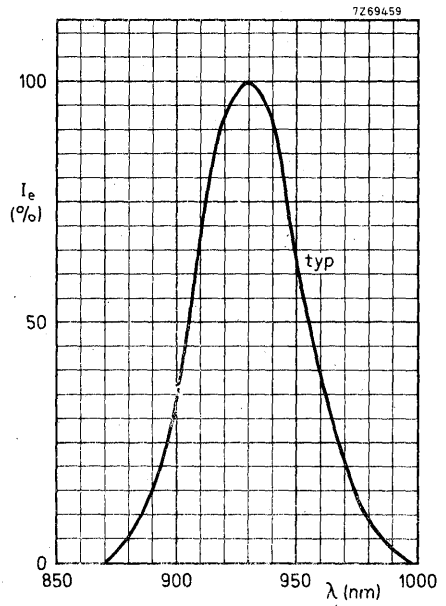
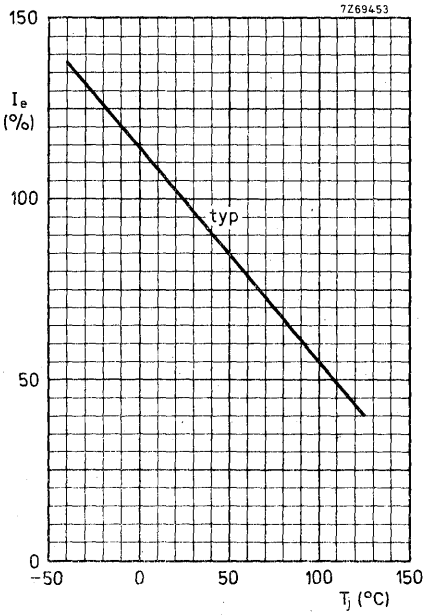

CQY50
CQY52

GaAs LIGHT EMITTING DIODES

Gallium arsenide light emitting diodes which emit near-infrared light when forward biased. Ceramic-metal envelope with glass lens like BPX71, suitable for matrix layout on printed circuit boards. In conjunction with BPX71 also suitable for punched card reading.

QUICK REFERENCE DATA

Continuous reverse voltage	V_R	max.	2	V				
Forward current (d. c.)	I_F	max.	100	mA				
Total power dissipation up to $T_{amb} = 25\text{ }^\circ\text{C}$ mounted on printed circuit board	P_{tot}	max.	150	mW				
Total radiant power at $I_F = 20\text{ mA}$	ϕ_e	>	<table border="1"> <thead> <tr> <th>CQY50</th> <th>CQY52</th> </tr> </thead> <tbody> <tr> <td>160</td> <td>400</td> </tr> </tbody> </table>	CQY50	CQY52	160	400	μW
CQY50	CQY52							
160	400							
Radiant intensity (on-axis) at $I_F = 20\text{ mA}$	I_e	>	<table border="1"> <thead> <tr> <th>CQY50</th> <th>CQY52</th> </tr> </thead> <tbody> <tr> <td>180</td> <td>450</td> </tr> </tbody> </table>	CQY50	CQY52	180	450	$\mu\text{W/sr}$
CQY50	CQY52							
180	450							
Wavelength at peak emission	λ_{pk}	typ.	930	nm				

MECHANICAL DATA

Dimensions in mm

DO-31 except for length

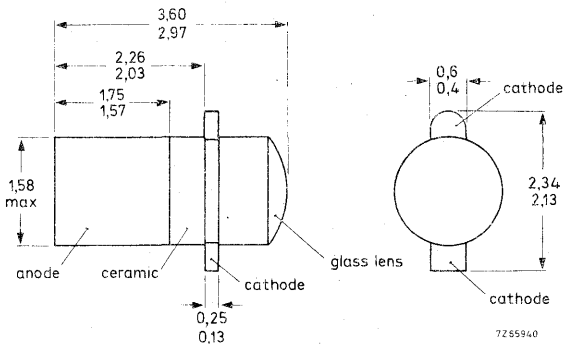

CQY50
CQY52

RATINGS Limiting values in accordance with the Absolute Maximum System (IEC 134)

Voltage

Continuous reverse voltage V_R max. 2 V

Current

Forward current (d.c.) I_F max. 100 mA

Forward current (peak value)
 $t_p = 10 \mu s; \delta = 0,01$ I_{FM} max. 500 mA

Temperature

Storage temperature T_{stg} -65 to +150 °C

Operating junction temperature T_j max. 125 °C

Power dissipation

Total power dissipation up to $T_{amb} = 25 \text{ °C}$
device mounted on p.c. board ¹⁾ P_{tot} max. 150 mW

THERMAL RESISTANCE

From junction to ambient,
device mounted on p.c. board ¹⁾ $R_{th j-a} = 0,66 \text{ °C/mW}$

¹⁾ With copper islands of 6 x 2 mm on both sides of 1,6 mm glass-epoxy printed circuit board; thickness of copper 35 μm .

CHARACTERISTICS

$T_{amb} = 25\text{ }^{\circ}\text{C}$ unless otherwise specified

		CQY50	CQY52	
<u>Forward voltage</u>				
$I_F = 50\text{ mA}$	V_F typ.	1,3	1,3	V
	V_F <	1,5	1,5	V
$I_F = 500\text{ mA}; t_p = 10\text{ }\mu\text{s}; \delta = 0,01$	V_F typ.	2,3	2,3	V
<u>Reverse current</u>				
$V_R = 2\text{ V}$	I_R <	100	100	μA
<u>Diode capacitance</u>				
$V_R = 0; f = 1\text{ MHz}$	C_d typ.	45	45	pF
<u>Total radiant power</u>				
$I_F = 20\text{ mA}$	ϕ_e >	160	400	μW
$I_F = 50\text{ mA}$	ϕ_e typ.	700	1500	μW
<u>Radiant intensity (on-axis)</u>				
$I_F = 20\text{ mA}$	I_e >	180	450	$\mu\text{W}/\text{sr}$
<u>Wavelength at peak emission</u>				
	λ_{pk} typ.	930	930	nm
<u>Bandwidth at half height</u>				
	$B_{50\%}$ typ.	40	40	nm
<u>Beamwidth between half-intensity directions</u>				
	$\alpha_{50\%}$ typ.	35 $^{\circ}$	35 $^{\circ}$	
<u>Switching times</u>				
$I_{Fon} = 20\text{ mA}; t_p = 2\text{ }\mu\text{s}; f = 45\text{ kHz}$				
Light rise time	t_r typ.	600	600	ns
Light fall time	t_f typ.	350	350	ns



**CQY50
CQY52**

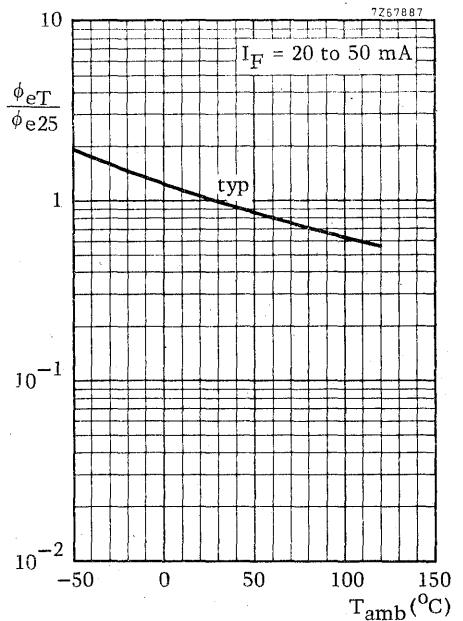
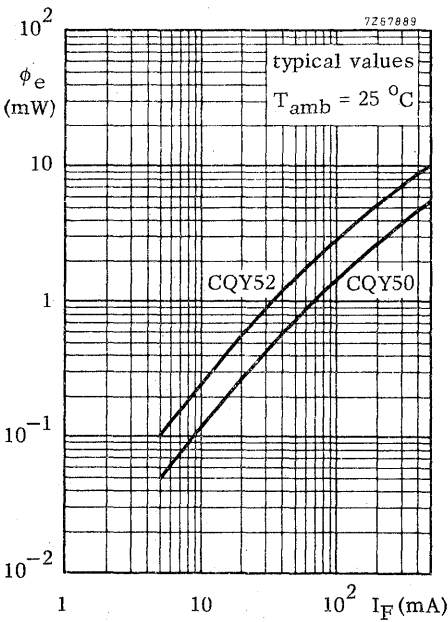
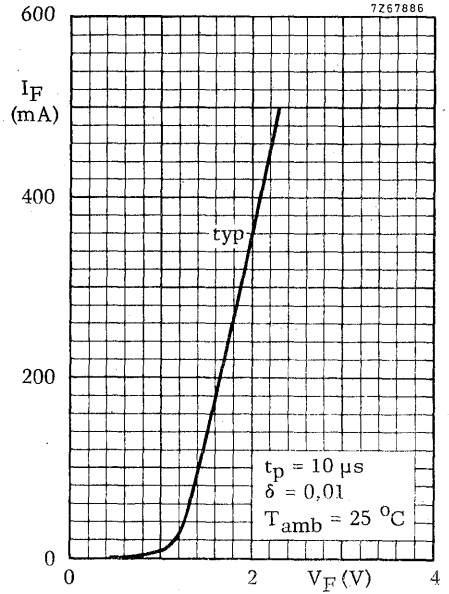
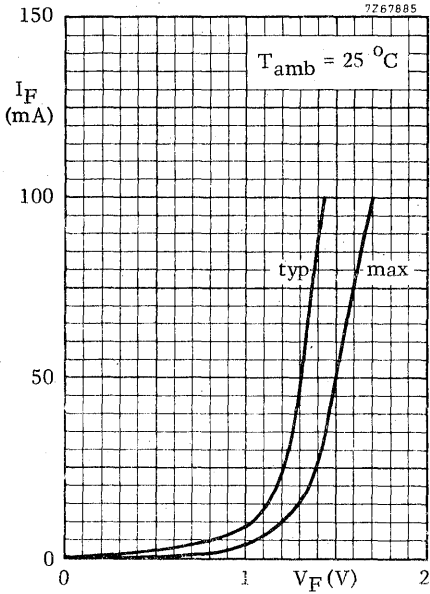

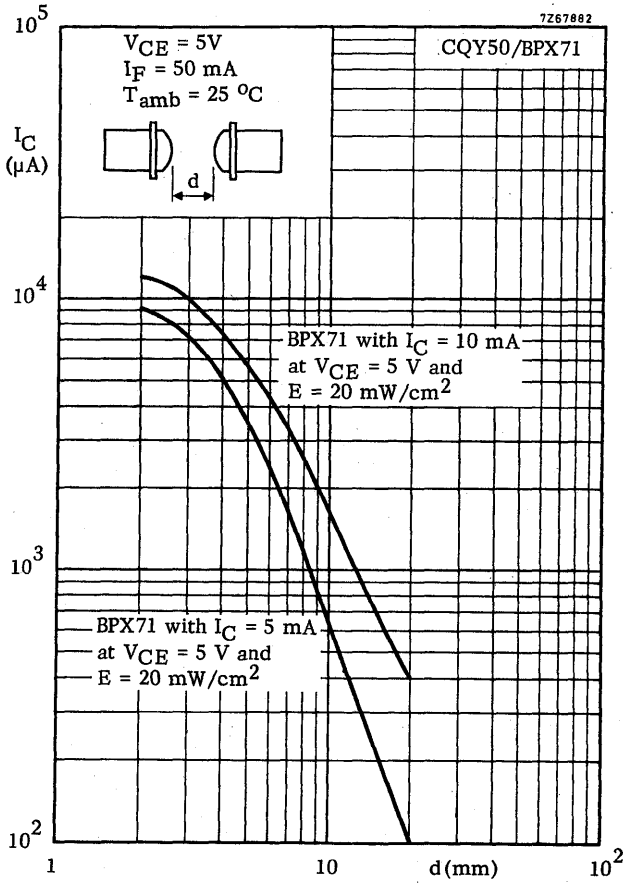

**CQY50
CQY52**

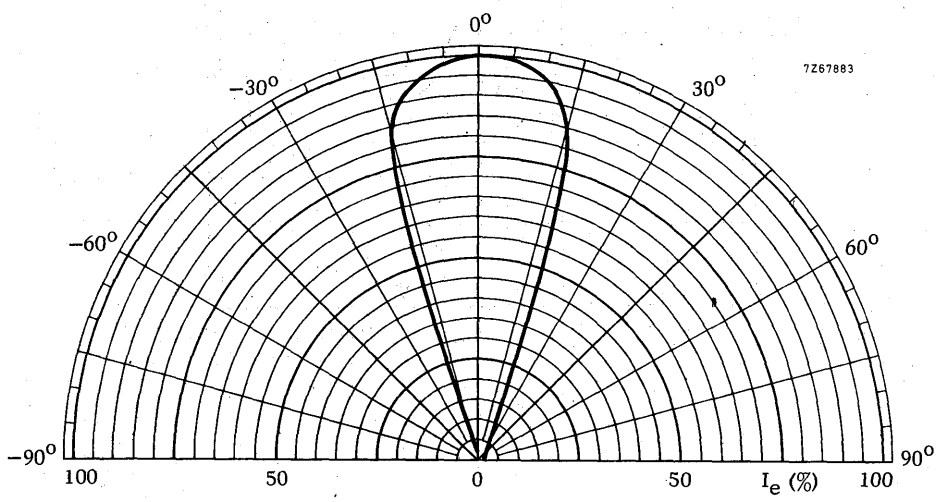
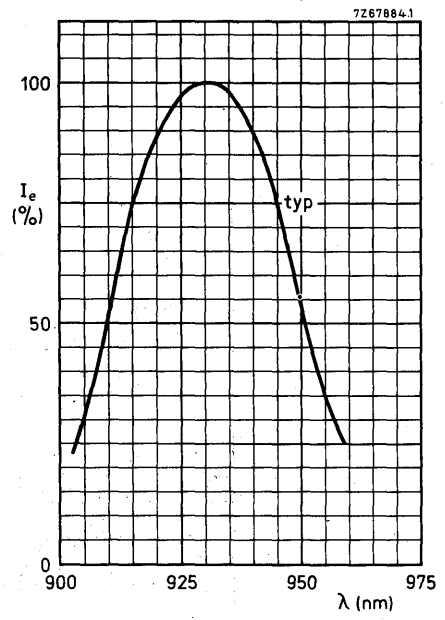
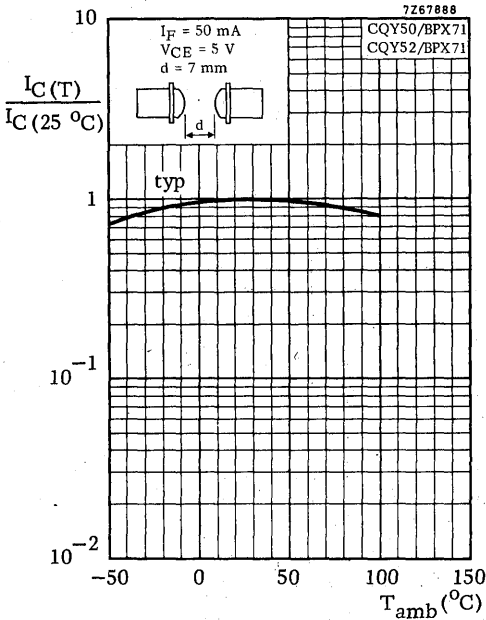

GaAsP RED LIGHT EMITTING DIODE

Gallium arsenide phosphide light emitting diode which emits visible red light when forward biased. The envelope is of light-diffusing red plastic, and has been designed for high-density arrays.

QUICK REFERENCE DATA

Continuous reverse voltage	V_R	max.	3 V
Forward current (d.c.)	I_F	max.	50 mA
Total power dissipation up to $T_{amb} = 37,5\text{ }^\circ\text{C}$	P_{tot}	max.	100 mW
Luminous intensity (on-axis) $I_F = 20\text{ mA}$	CQY54	I_v	> 0,3 mcd
	CQY54-I	I_v	0,7 to 1,6 mcd
	CQY54-II	I_v	1 to 2,2 mcd
	CQY54-III	I_v	> 1,6 mcd
Wavelength at peak emission	λ_{pk}	typ.	650 nm
Beamwidth between half-intensity directions	$\alpha_{50\%}$	typ.	80°

MECHANICAL DATA

Dimensions in mm

Fig. 1 SOD-53C.

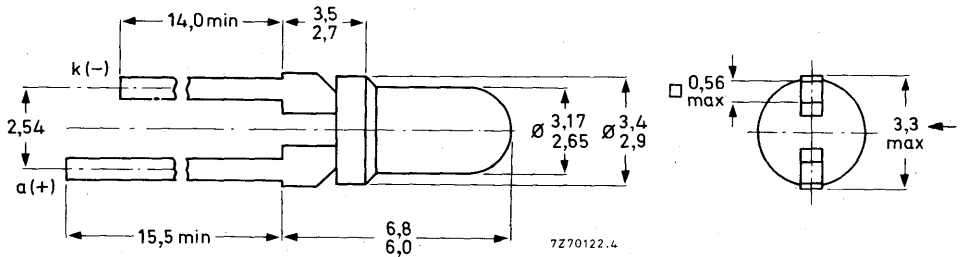

RATINGS

Limiting values in accordance with the Absolute Maximum System (IEC 134)

Continuous reverse voltage	V_R	max.	3 V
Forward current (d.c.)	I_F	max.	50 mA
Forward current (peak value) $t_p = 1 \mu s; f = 300 \text{ Hz}$	I_{FM}	max.	1000 mA
Storage temperature	T_{stg}		-55 to +100 °C
Junction temperature	T_j	max.	100 °C
Total power dissipation up to $T_{amb} = 37,5 \text{ °C}$	P_{tot}	max.	100 mW

THERMAL RESISTANCE

From junction to ambient,
in free air
mounted on a p.c. board

$R_{th j-a}$	=	0,625 °C/mW
$R_{th j-a}$	=	0,500 °C/mW

CHARACTERISTICS

 $T_j = 25\text{ }^\circ\text{C}$

Forward voltage

 $I_F = 20\text{ mA}$ Negative temperature coefficient of V_F $I_F = 20\text{ mA}$

Reverse current

 $V_R = 3\text{ V}$

Luminous intensity (on-axis)

 $I_F = 20\text{ mA}$

Diode capacitance

 $V_R = 0; F = 1\text{ MHz}$

Wavelength at peak emission

Bandwidth at half height

Beamwidth between half-intensity directions

V_F	typ.	1,7 V
	<	2,0 V

$\frac{-\Delta V_F}{\Delta T_j}$	typ.	1,6 mV/°C
----------------------------------	------	-----------

$\frac{-\Delta V_F}{\Delta T_j}$	typ.	2 mV/°C
----------------------------------	------	---------

I_R	<	100 μA
-------	---	-------------------

CQY54

I_v	>	0,3 mcd
-------	---	---------

CQY54-I

I_v		0,7 to 1,6 mcd
-------	--	----------------

CQY54-II

I_v		1 to 2,2 mcd
-------	--	--------------

CQY54-III

I_v	>	1,6 mcd
-------	---	---------

C_d	typ.	60 pF
-------	------	-------

λ_{pk}	typ.	650 nm
----------------	------	--------

$B_{50\%}$	typ.	20 nm
------------	------	-------

$\alpha_{50\%}$	typ.	80°
-----------------	------	-----

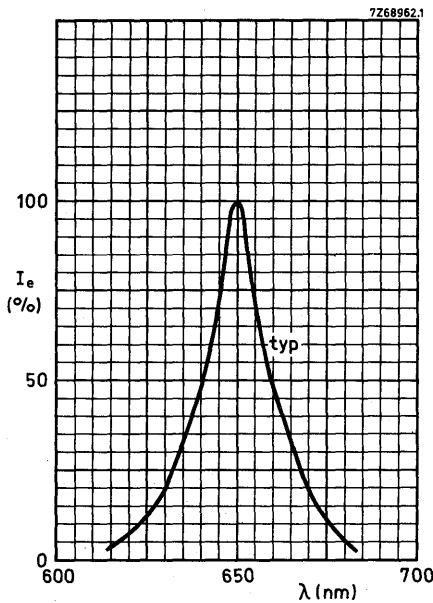
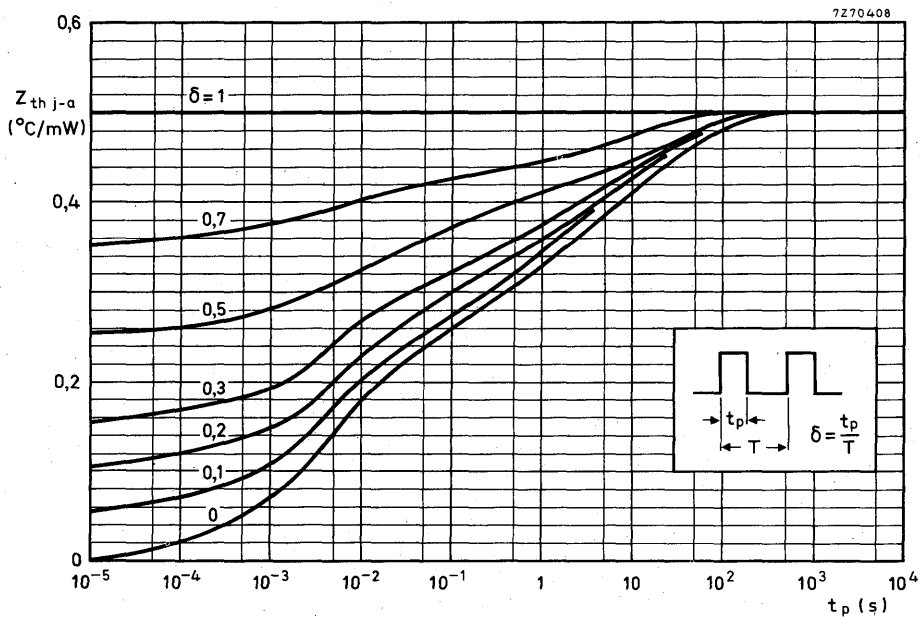
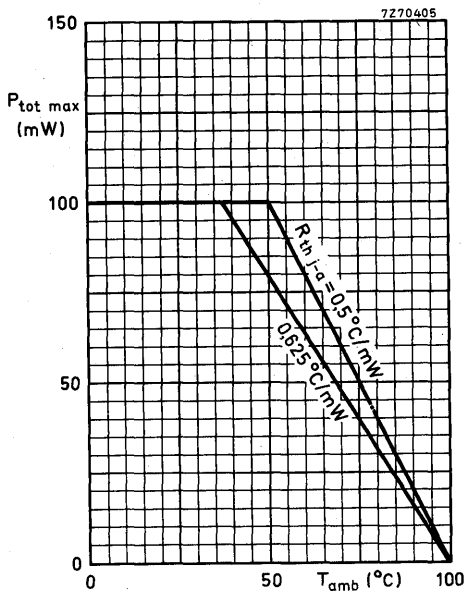
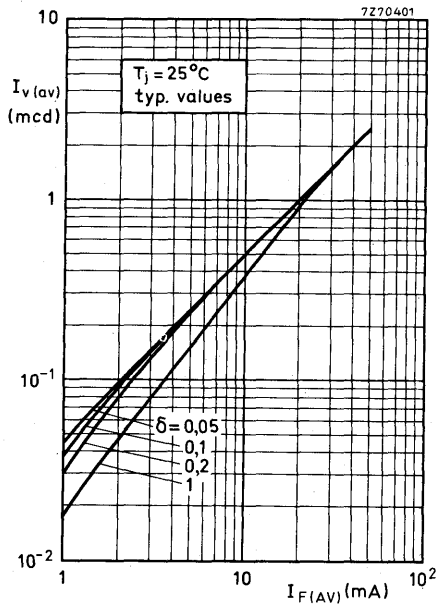
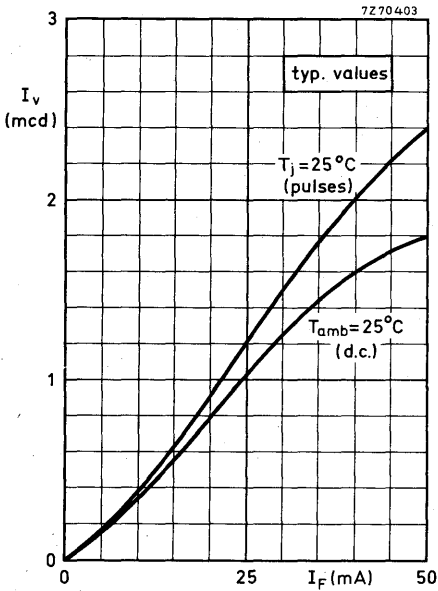
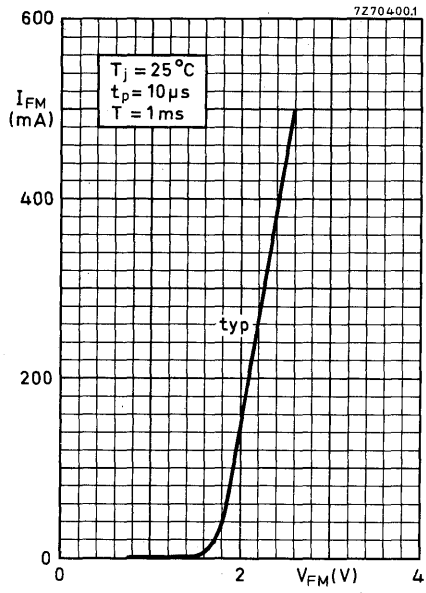
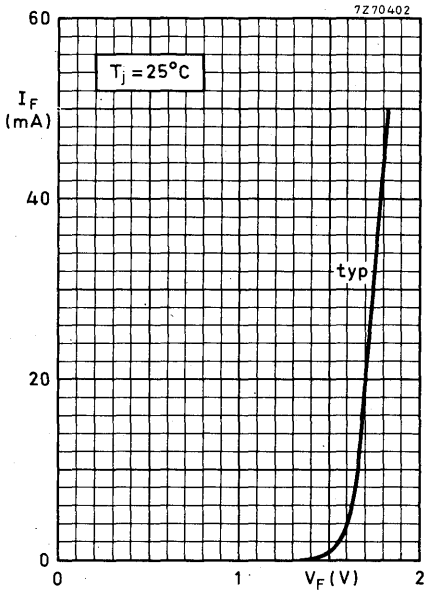
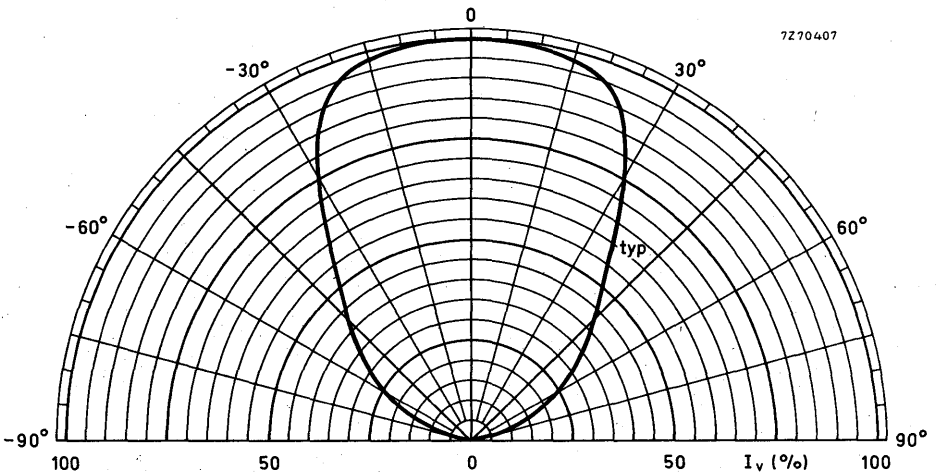
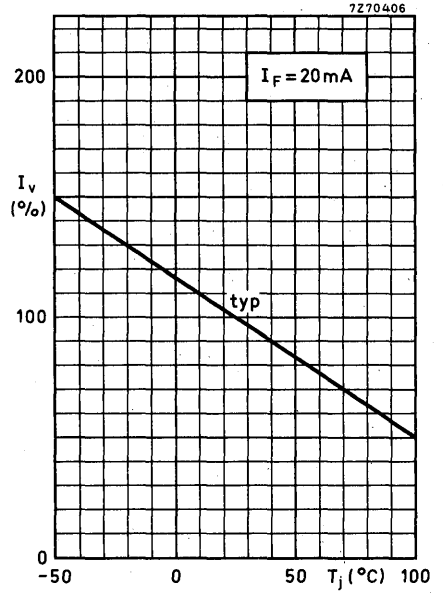
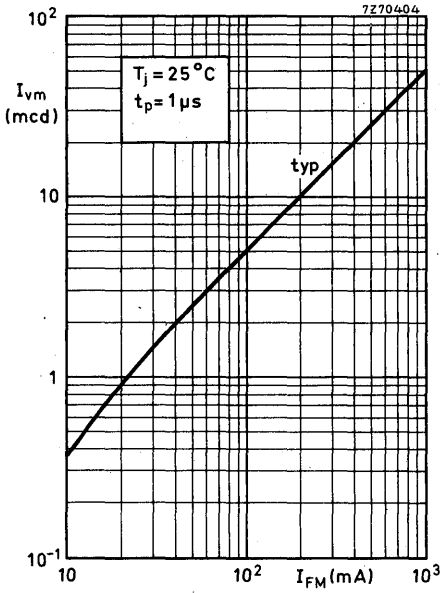

Fig. 2.







GaAs LIGHT EMITTING DIODE

Diffused planar gallium arsenide light emitting diode intended for optical coupling and encoding. It emits radiation in the near infrared when forward biased. Red epoxy resin envelope with lens. Combination with phototransistor BPW22 is recommended.

QUICK REFERENCE DATA

Continuous reverse voltage	V_R	max.	2 V
Forward current (d. c.)	I_F	max.	50 mA
Total power dissipation up to $T_{amb} = 25\text{ }^\circ\text{C}$	P_{tot}	max.	75 mW
Radiant output power at $I_F = 20\text{ mA}$	ϕ_e	typ.	500 μW
Radiant intensity (on-axis) at $I_F = 20\text{ mA}$	I_e	>	400 $\mu\text{W/sr}$
Wavelength at peak emission	λ_{pk}	typ.	875 nm
Thermal resistance from junction to ambient	$R_{th\ j-a}$	=	1 $^\circ\text{C/mW}$

MECHANICAL DATA

Dimensions in mm

SOD-53D

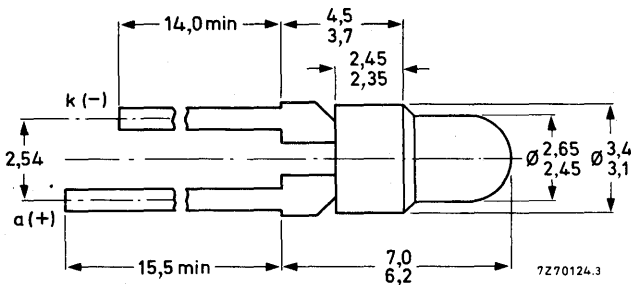

RATINGS Limiting values in accordance with the Absolute Maximum System (IEC 134)

Voltage

Continuous reverse voltage V_R max. 2 V

Current

Forward current (d.c.) I_F max. 50 mA

Forward current (peak value)

$t_p = 10 \mu s; \delta = 0,01$

I_{FM} max. 200 mA

Temperature

Storage temperature T_{stg} -55 to +100 °C

Junction temperature T_j max. 100 °C

Lead soldering temperature

> 3 mm from the body; $t_{sld} < 7 s$

T_{sld} max. 230 °C

Power dissipation

Total power dissipation up to $T_{amb} = 25 \text{ °C}$,
device mounted on printed-circuit board

P_{tot} max. 75 mW

THERMAL RESISTANCE

From junction to ambient,

device mounted on printed-circuit board

$R_{th j-a} = 1 \text{ °C/mW}$

CHARACTERISTICS

$T_j = 25\text{ }^\circ\text{C}$ unless otherwise specified

Forward voltage

$I_F = 20\text{ mA}$

V_F typ. 1,2 V
 < 1,5 V

Reverse current

$V_R = 2\text{ V}$

I_R < 100 μA

Diode capacitance

$V_R = 0; f = 1\text{ MHz}$

C_d typ. 80 pF

Total radiant power

$I_F = 20\text{ mA}$

ϕ_e typ. 500 μW

Radiant intensity (on-axis)

$I_F = 20\text{ mA}$

I_e > 400 $\mu\text{W/sr}$
 typ. 800 $\mu\text{W/sr}$

Wavelength at peak emission

λ_{pk} typ. 875 nm

Bandwidth at half height

$B_{50\%}$ typ. 50 nm

Beamwidth between half-intensity directions

$\alpha_{50\%}$ typ. 10°

Switching times

$I_{Fon} = 50\text{ mA}; t_p = 100\text{ ns}; f = 100\text{ kHz}$

Light rise time

t_r typ. 20 ns

Light fall time

t_f typ. 20 ns



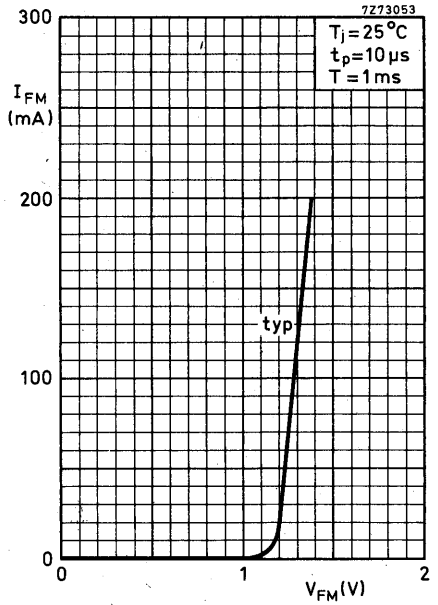
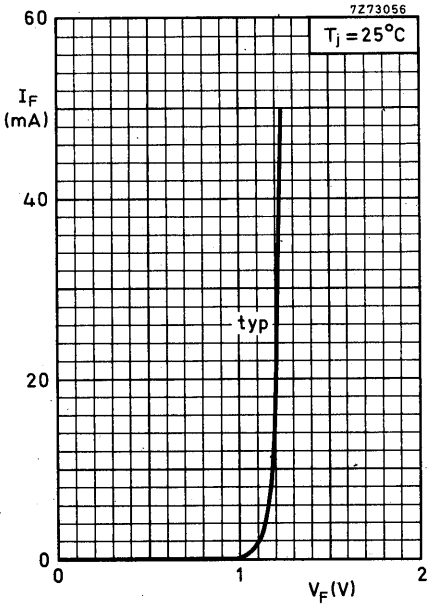
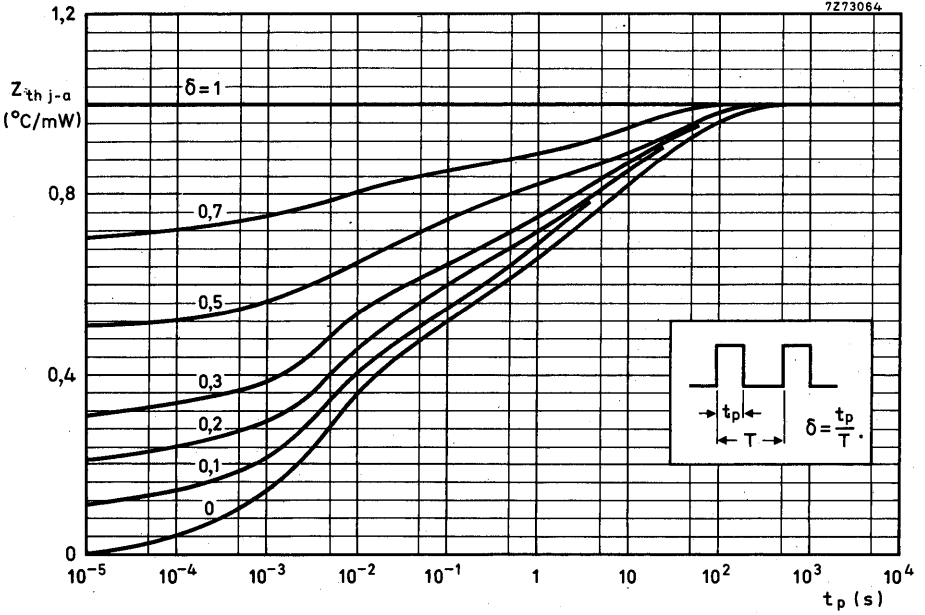

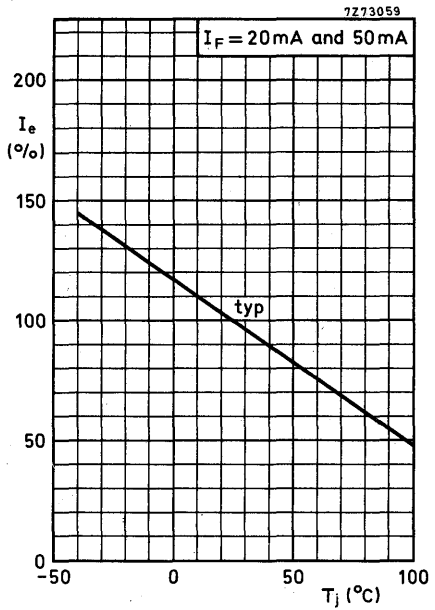
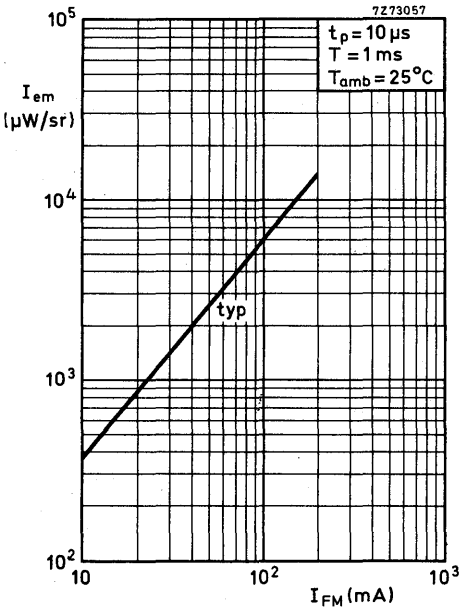
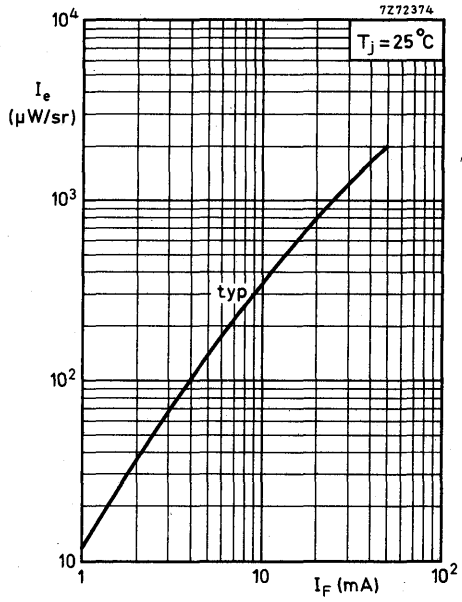
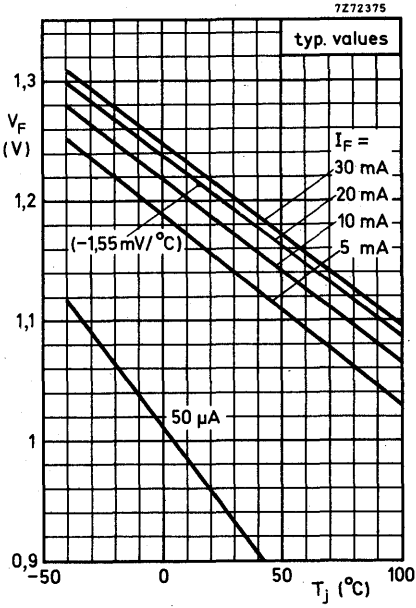

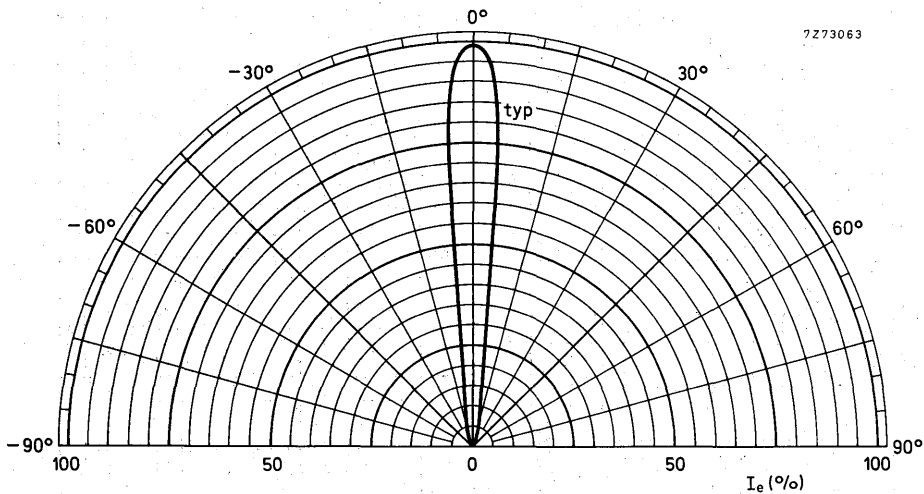
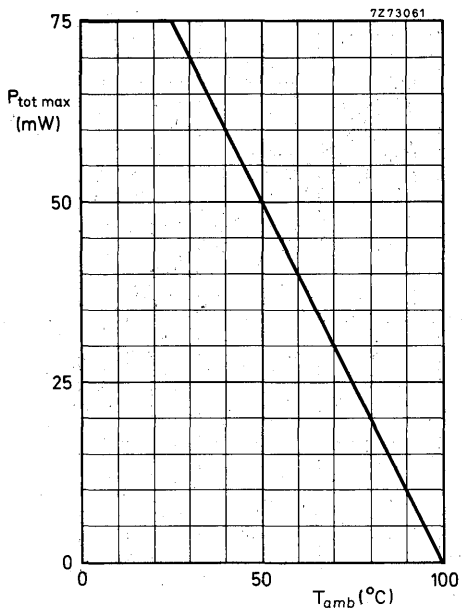
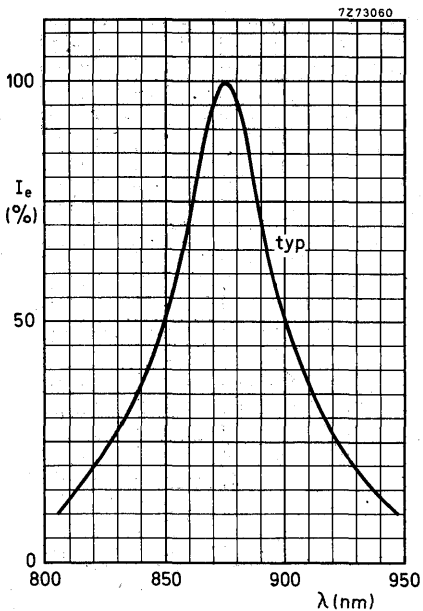

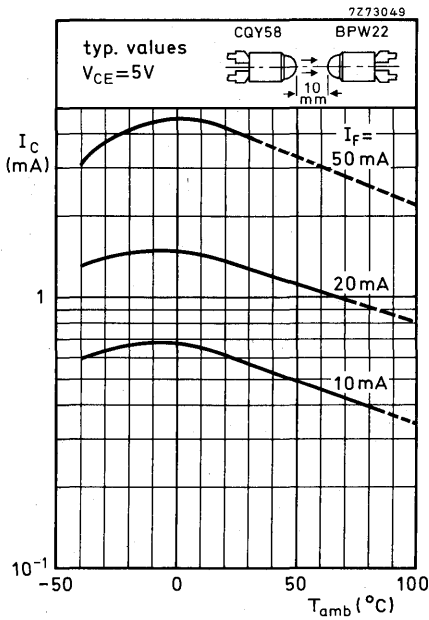
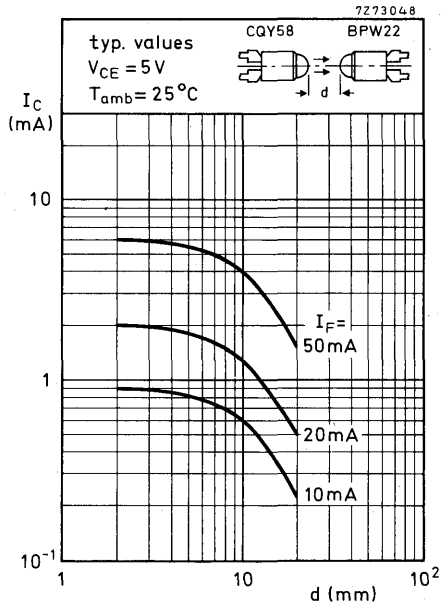
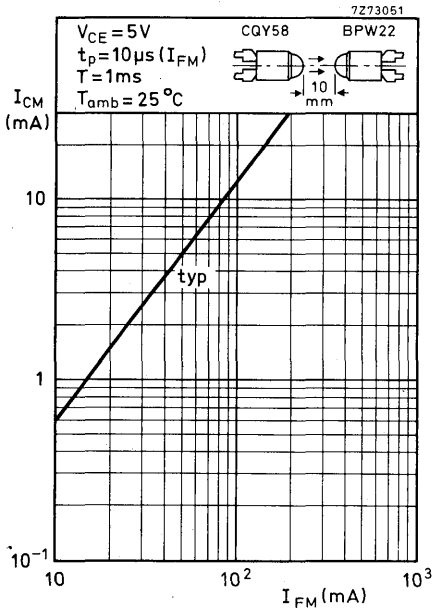

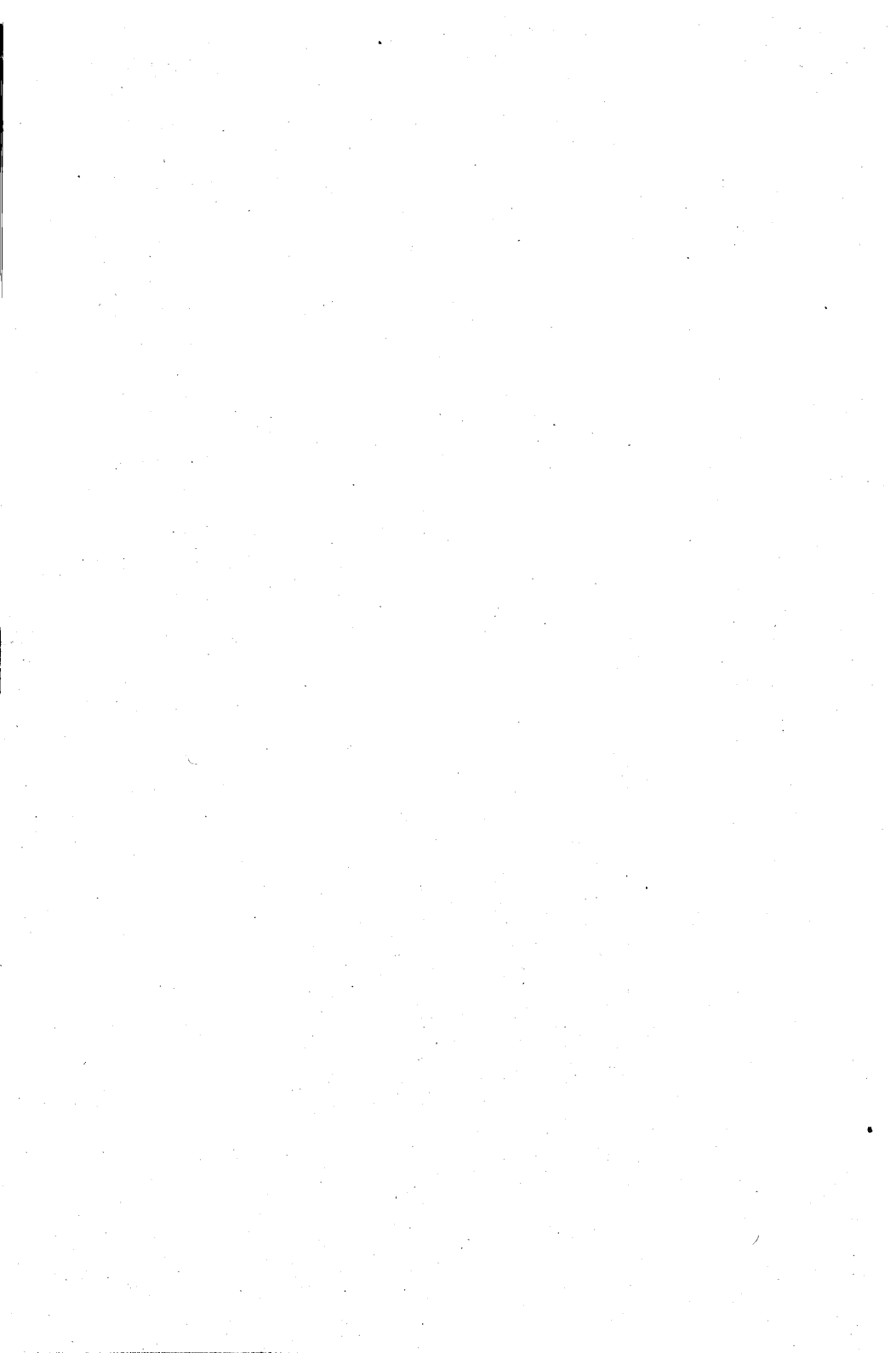

GaAsP RED LIGHT EMITTING DIODE

Gallium arsenide phosphide light emitting diode which emits visible red light when forward biased. The envelope is of non-diffusing red plastic. It is intended for low-current drive (5 mA) applications.

QUICK REFERENCE DATA			
Continuous reverse voltage	V_R	max.	3 V
Forward current (d. c.)	I_F	max.	10 mA
Total power dissipation up to $T_{amb.} = 60\text{ }^\circ\text{C}$	P_{tot}	max.	20 mW
Luminous intensity (on-axis) $I_F = 5\text{ mA}$	I_v	>	0,3 mcd
Wavelength at peak emission	λ_{pk}	typ.	650 nm
Beamwidth between half-intensity directions	$\alpha_{50\%}$	typ.	50°
Thermal resistance from junction to ambient in free air	$R_{th\ j-a}$	=	2 $^\circ\text{C}/\text{mW}$

MECHANICAL DATA

Dimensions in mm

SOD-53C

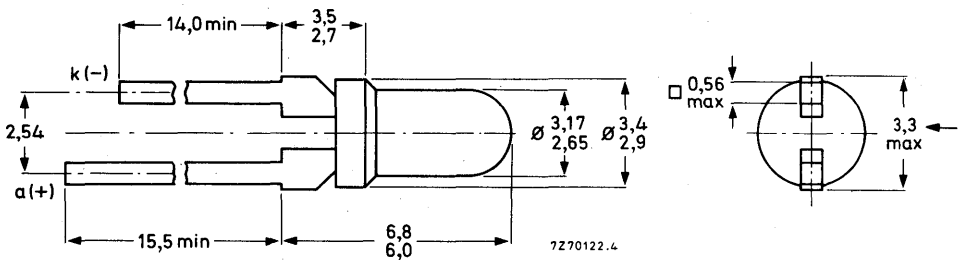

RATINGS Limiting values in accordance with the Absolute Maximum System (IEC 134)

Voltage

Continuous reverse voltage V_R max. 3 V

Current

Forward current (d. c.) I_F max. 10 mA

Forward current (peak value)
 $t_p = 1 \mu s$; $f = 300 \text{ Hz}$ I_{FM} max. 100 mA

Power dissipation

Total power dissipation up to $T_{amb} = 60 \text{ }^\circ\text{C}$ P_{tot} max. 20 mW

Temperatures

Storage temperature T_{stg} -55 to +100 $^\circ\text{C}$

Junction temperature T_j max. 100 $^\circ\text{C}$

Lead soldering temperature
 > 3 mm from the body; $t_{sld} < 7 \text{ s}$ T_{sld} max. 230 $^\circ\text{C}$

THERMAL RESISTANCE

From junction to ambient in free air $R_{th j-a}$ = 2 $^\circ\text{C/mW}$

CHARACTERISTICS

Forward voltage

$I_F = 5 \text{ mA}$ V_F typ. 1,7 V
 < 2 V

Reverse current

$V_R = 3 \text{ V}$ I_R < 100 μA

Diode capacitance

$V_R = 0$; $f = 1 \text{ MHz}$ C_d typ. 30 pF

Luminous intensity (on-axis)

$I_F = 5 \text{ mA}$ I_v > 0,3 mcd
 typ. 0,5 mcd

Wavelength at peak emission

λ_{pk} typ. 650 nm

Bandwidth at half height

$B_{50\%}$ typ. 20 nm

Beamwidth between half-intensity directions

$\alpha_{50\%}$ typ. 50 $^\circ$

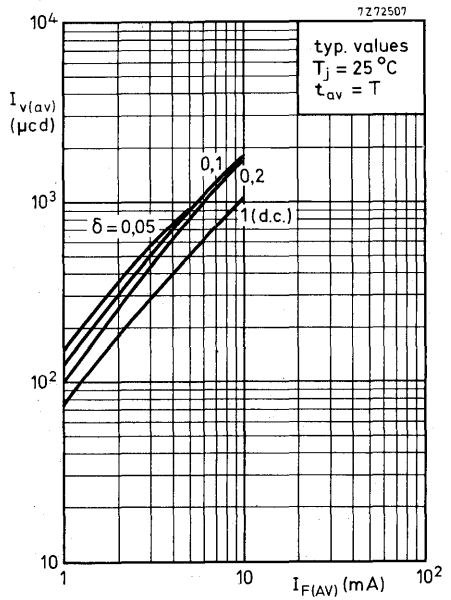
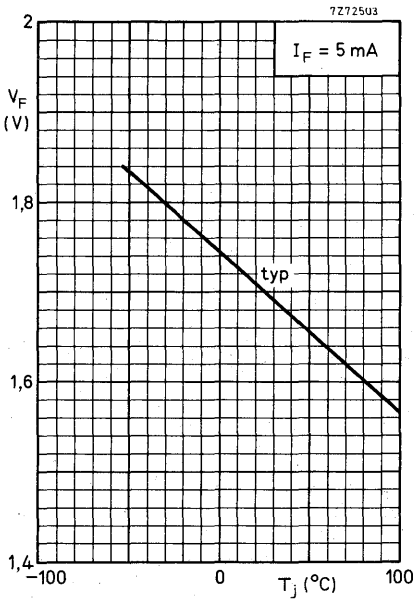
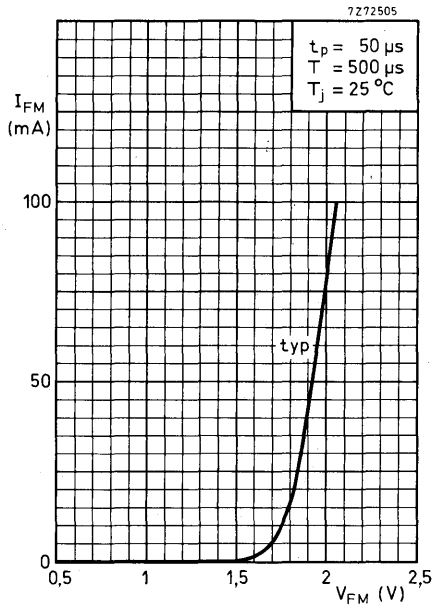
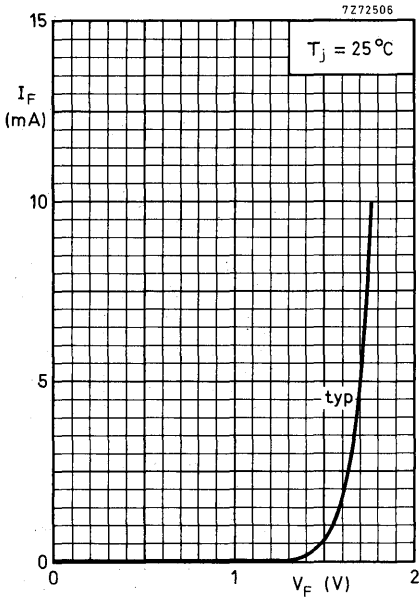

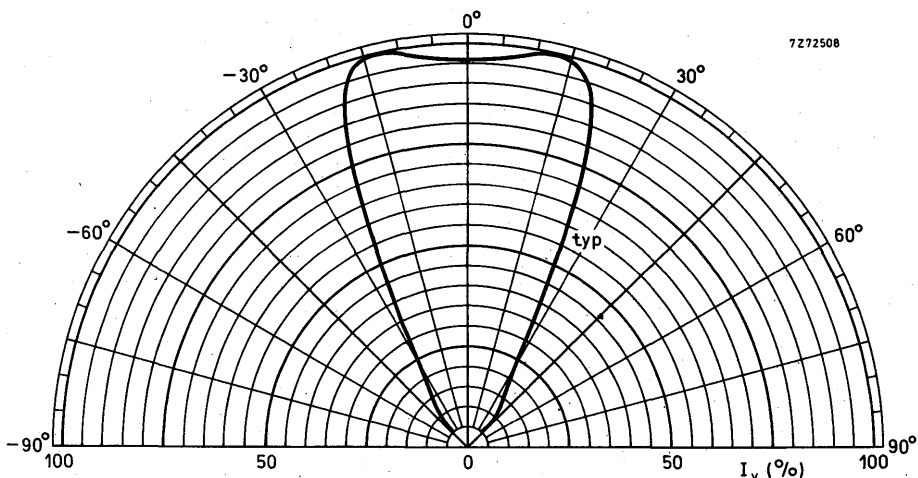
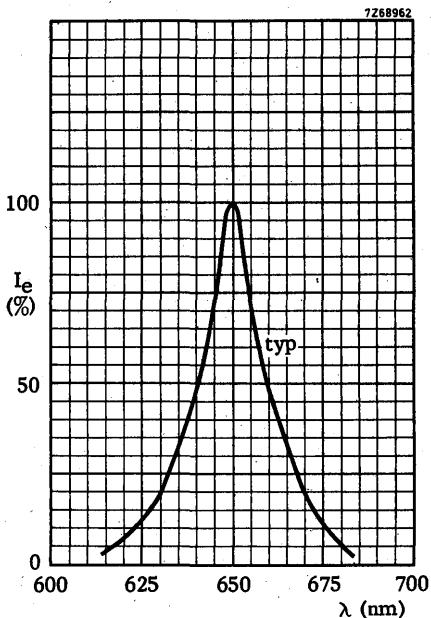
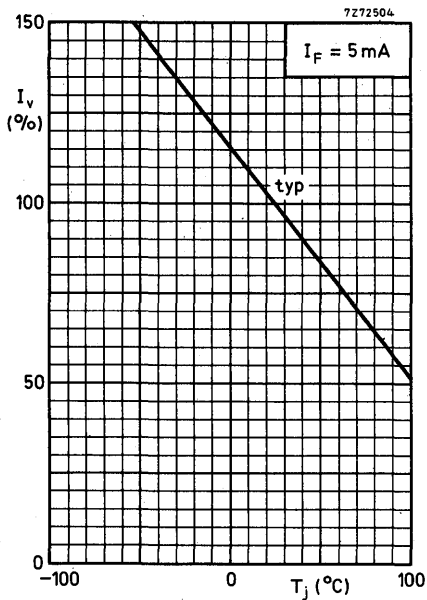

GaAs LIGHT EMITTING DIODE

Epitaxial gallium arsenide light emitting diode intended for remote-control applications. It emits radiation in the near infrared when forward biased. Clear epoxy encapsulation.

QUICK REFERENCE DATA

Continuous reverse voltage	V_R	max.	5 V
Forward current (d. c.)	I_F	max.	130 mA
Junction temperature	T_j	max.	100 °C
Total power dissipation up to $T_{amb} = 25\text{ °C}$	P_{tot}	max.	215 mW
Radiant intensity (on-axis) at $I_F = 100\text{ mA}$	I_e	>	7 mW/sr
Wavelength at peak emission	λ_{pk}	typ.	930 nm

MECHANICAL DATA

Dimensions in mm

SOD-63

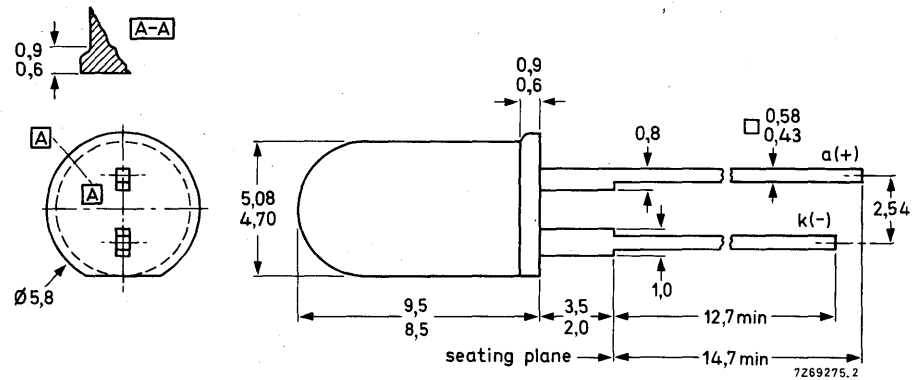

RATINGS Limiting values in accordance with the Absolute Maximum System (IEC 134)Voltage

Continuous reverse voltage	V_R	max.	5 V
----------------------------	-------	------	-----

Current

Forward current (d. c.)	I_F	max.	130 mA
-------------------------	-------	------	--------

Forward current (peak value)	I_{FM}	max.	1000 mA
------------------------------	----------	------	---------

$t_p \leq 50 \mu s; \delta = 0,05$

Non-repetitive peak forward current ($t_p \leq 10 \mu s$)	I_{FSM}	max.	2500 mA
---	-----------	------	---------

Power dissipation

Total power dissipation up to $T_{amb} = 25 \text{ }^\circ\text{C}$	P_{tot}	max.	215 mW
---	-----------	------	--------

Temperatures

Storage temperature	T_{stg}	-55 to +100	$^\circ\text{C}$
---------------------	-----------	-------------	------------------

Junction temperature	T_j	max.	100 $^\circ\text{C}$
----------------------	-------	------	----------------------

Lead soldering temperature	T_{sld}	max.	260 $^\circ\text{C}$
----------------------------	-----------	------	----------------------

up to the seating plane; $t_{sld} < 10 \text{ s}$

THERMAL RESISTANCE

From junction to ambient	$R_{th j-a}$	=	0,35 $^\circ\text{C}/\text{mW}$
--------------------------	--------------	---	---------------------------------

mounted on a printed-circuit board

CHARACTERISTICS

$T_j = 25\text{ }^\circ\text{C}$ unless otherwise specified

Forward voltage

$I_F = 100\text{ mA}$

V_F typ. 1,4 V
< 1,6 V

$I_{FM} = 1500\text{ mA}; t_p = 20\text{ }\mu\text{s}; \delta = 0,033$

V_{FM} typ. 2,4 V

Reverse current

$V_R = 5\text{ V}$

I_R < 100 μA

Diode capacitance

$V_R = 0; f = 1\text{ MHz}$

C_d typ. 40 pF

Total radiant power

$I_F = 100\text{ mA}$

ϕ_e > 5 mW
typ. 8 mW

Decrease of radiant power with temperature

$I_F = 100\text{ mA}$

$\frac{\Delta\phi_e}{\Delta T_j}$ typ. 1 $\% / ^\circ\text{C}$

Radiant intensity (on-axis)

$I_F = 100\text{ mA}$

I_e > 7 mW/sr
typ. 12 mW/sr

Wavelength at peak emission

$I_F = 100\text{ mA}$

λ_{pk} typ. 930 nm

Bandwidth at half height

$I_F = 100\text{ mA}$

$B_{50\%}$ typ. 50 nm

Beamwidth between half-intensity directions

$I_F = 100\text{ mA}$

$\alpha_{50\%}$ typ. 30°

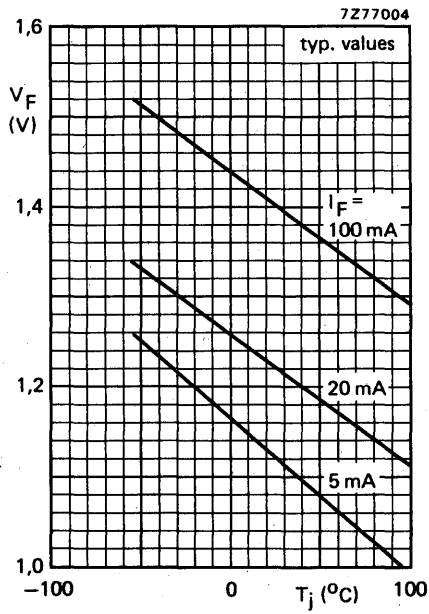
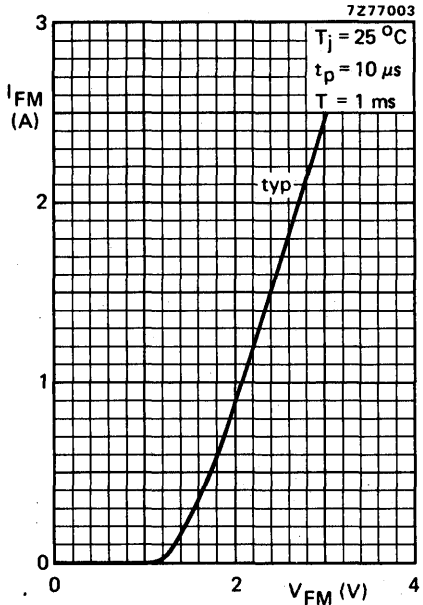
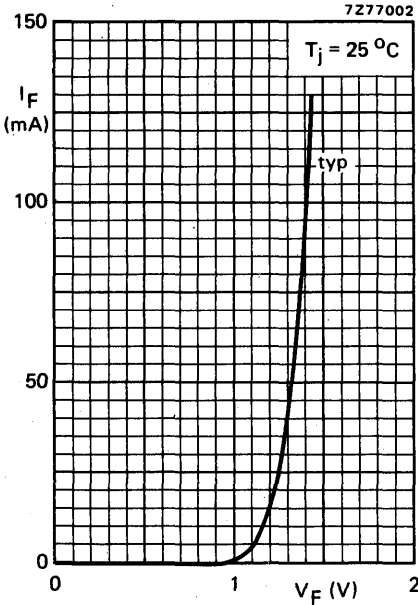

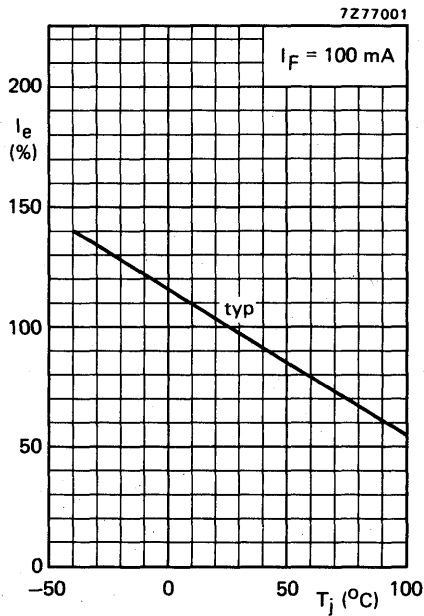
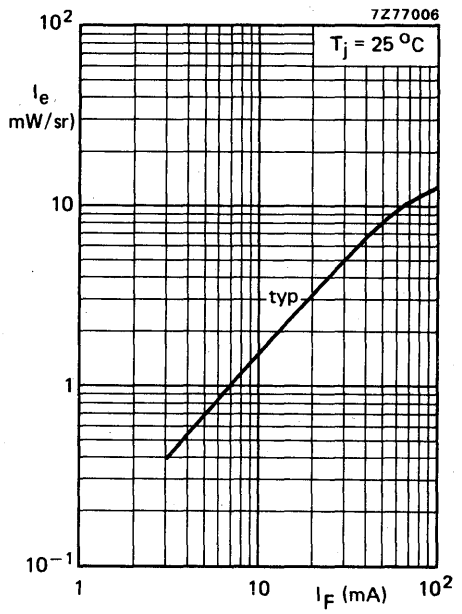
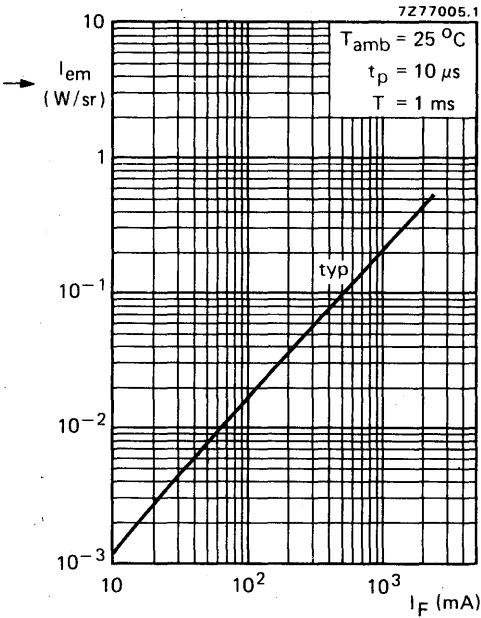

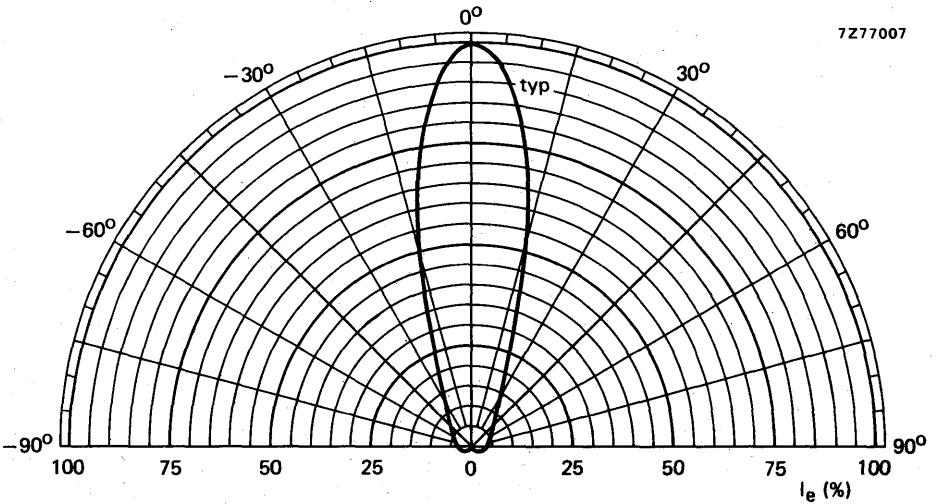
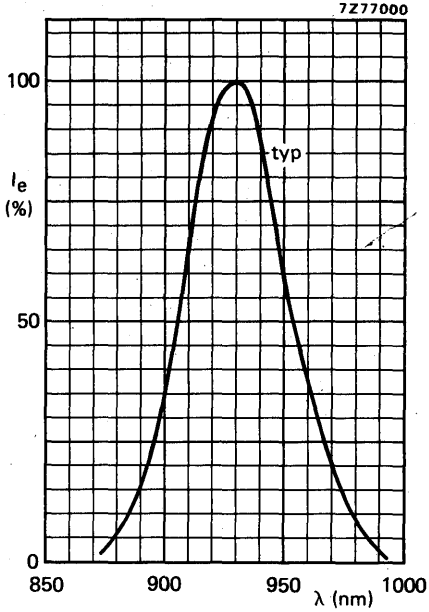

GaP GREEN LIGHT EMITTING DIODE

Gallium phosphide light emitting diode which emits green light when forward biased. Green, light-diffusing plastic envelope.

QUICK REFERENCE DATA

Continuous reverse voltage	V_R	max.	3 V
Forward current (d.c.)	I_F	max.	20 mA
Total power dissipation up to $T_{amb} = 55\text{ }^\circ\text{C}$	P_{tot}	max.	60 mW
Luminous intensity (on-axis) at $I_F = 10\text{ mA}$	CQY94	I_v	> 0,3 mcd ←
	CQY94-I	I_v	0,7 to 1,6 mcd
	CQY94-II	I_v	1,0 to 2,2 mcd
	CQY94-III	I_v	> 1,6 mcd
Wavelength at peak emission	λ_{pk}	typ.	560 nm
Beamwidth between half-intensity directions	$\alpha_{50\%}$	typ.	60°

MECHANICAL DATA

Dimensions in mm

Fig. 1 SOD-63.

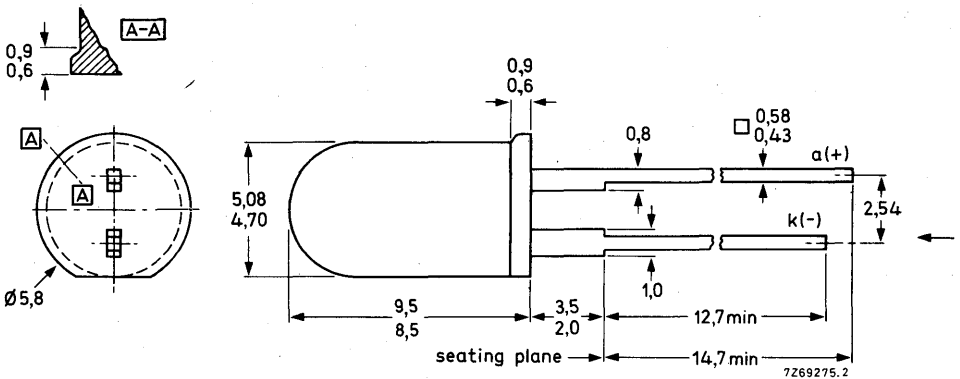

RATINGS

Limiting values in accordance with the Absolute Maximum System (IEC 134)

Continuous reverse voltage	V_R	max.	3 V
Forward current (d.c.)	I_F	max.	20 mA
Forward current (peak value)			
$t_p < 1 \text{ ms}; f < 300 \text{ Hz}$	I_{FM}	max.	60 mA
$t_p < 1 \mu\text{s}; f < 300 \text{ Hz}$	I_{FM}	max.	1000 mA
Total power dissipation up to $T_{amb} = 55 \text{ }^\circ\text{C}$	P_{tot}	max.	60 mW
Storage temperature	T_{stg}	max.	100 $^\circ\text{C}$
Junction temperature	T_j		-55 to + 100 $^\circ\text{C}$
Lead soldering temperature			
> 1,5 mm from the seating plane; $t_{sld} < 7 \text{ s}$	T_{sld}	max.	230 $^\circ\text{C}$

THERMAL RESISTANCE

From junction to ambient
in free air

$R_{th \text{ j-a}} = 0,75 \text{ }^\circ\text{C/mW}$

mounted on a printed-circuit board

$R_{th \text{ j-a}} = 0,5 \text{ }^\circ\text{C/mW}$

CHARACTERISTICS

$T_j = 25 \text{ }^\circ\text{C}$ unless otherwise specified

Forward voltage

$I_F = 10 \text{ mA}$

V_F typ. 2,1 V
< 3 V

Reverse current

$V_R = 3 \text{ V}$

I_R < 100 μA

Diode capacitance

$V_R = 0; f = 1 \text{ MHz}$

C_d typ. 35 pF

→ Luminous intensity (on-axis)

$I_F = 10 \text{ mA}$

CQY94	I_v	>	0,3 mcd
CQY94-I	I_v		0,7 to 1,6 mcd
CQY94-II	I_v		1,0 to 2,2 mcd
CQY94-III	I_v	>	1,6 mcd

Wavelength at peak emission

λ_{pk} typ. 560 nm

Bandwidth at half height

$B_{50\%}$ typ. 30 nm

Beamwidth between half-intensity directions

$\alpha_{50\%}$ typ. 60 $^\circ$

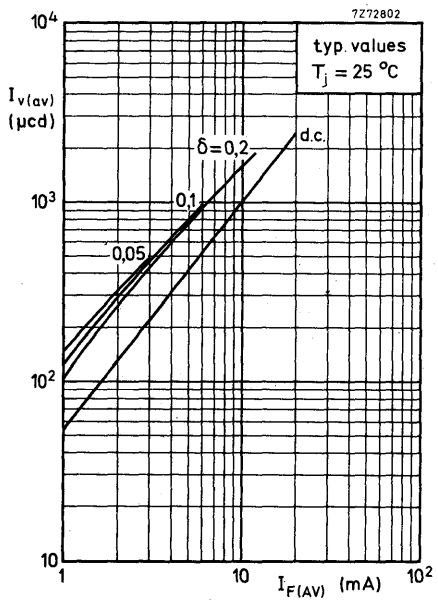
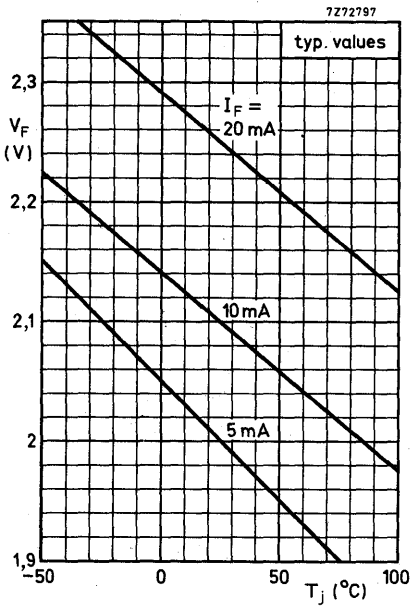
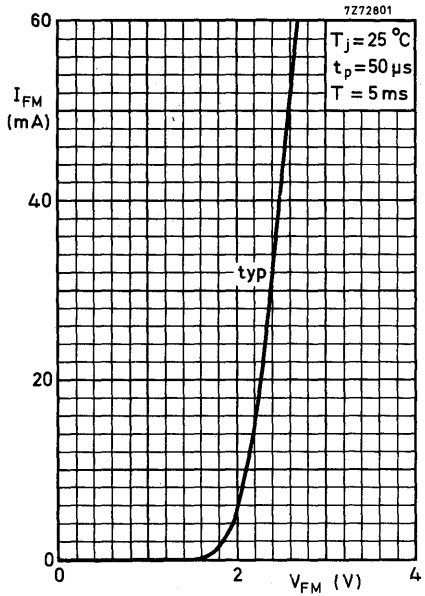
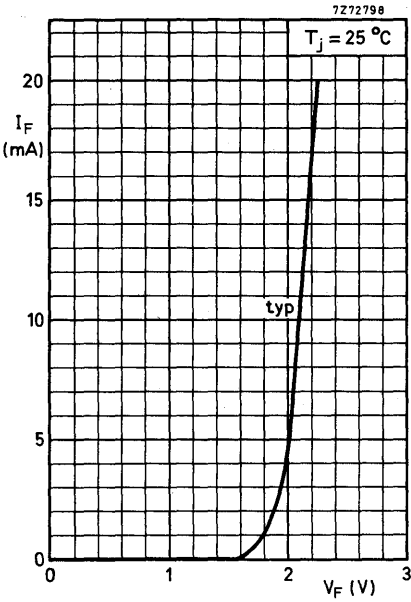

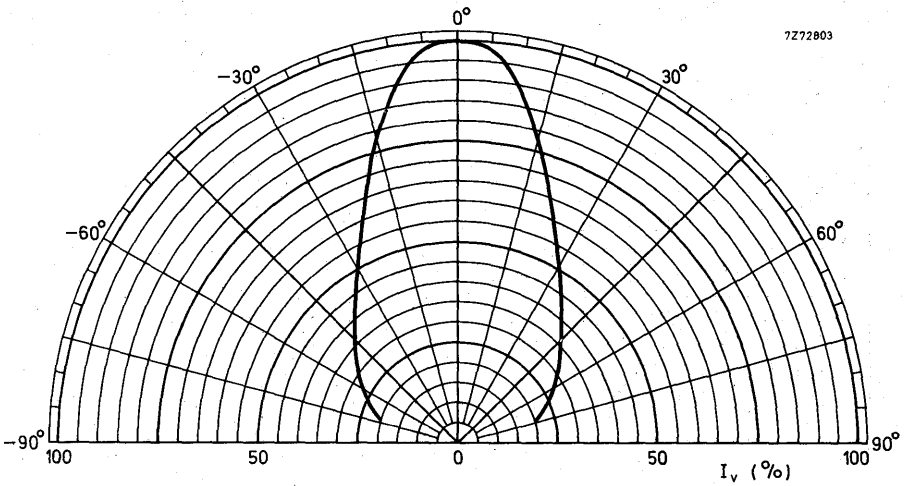
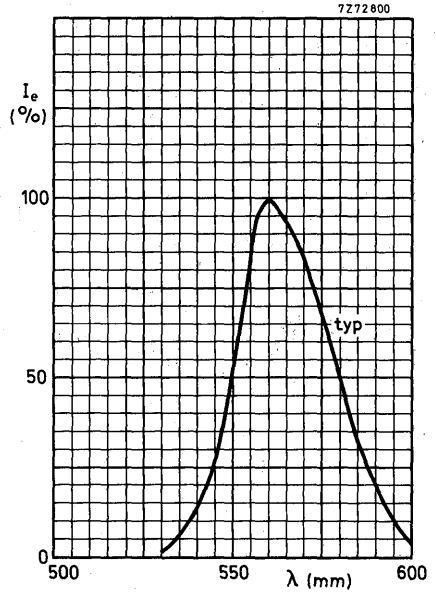
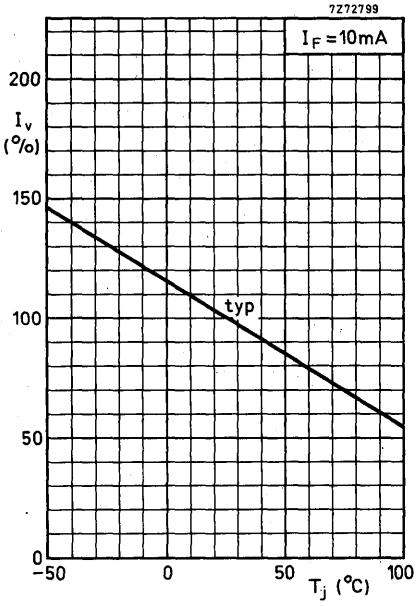

GaP GREEN LIGHT EMITTING DIODE

Gallium phosphide light emitting diode which emits green light when forward biased. Green, light-diffusing plastic envelope.

QUICK REFERENCE DATA

Continuous reverse voltage	V_R	max.	3 V
Forward current (d.c.)	I_F	max.	20 mA
Total power dissipation up to $T_{amb} = 55\text{ }^\circ\text{C}$	P_{tot}	max.	60 mW
Luminous intensity (on-axis) at $I_F = 10\text{ mA}$	CQY95	I_V	> 0,3 mcd ←
	CQY95-I	I_V	0,7 to 1,6 mcd
	CQY95-II	I_V	1,0 to 2,2 mcd
	CQY95-III	I_V	> 1,6 mcd
Wavelength at peak emission	λ_{pk}	typ.	560 nm
Beamwidth between half-intensity directions	$\alpha_{50\%}$	typ.	60°

MECHANICAL DATA

Dimensions in mm

Fig. 1 SOD-53C.

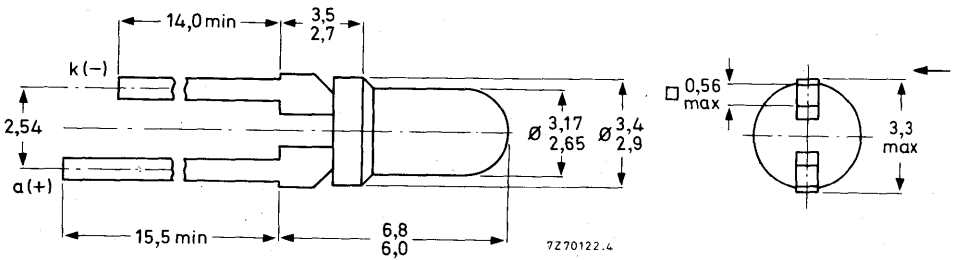

RATINGS

Limiting values in accordance with the Absolute Maximum System (IEC 134)

Continuous reverse voltage	V_R	max.	3 V
Forward current (d.c.)	I_F	max.	20 mA
Forward current (peak value)			
$t_p < 1$ ms; $f < 300$ Hz	I_{FM}	max.	60 mA
$t_p < 1$ μ s; $f < 300$ Hz	I_{FM}	max.	1000 mA
Total power dissipation up to $T_{amb} = 55$ °C	P_{tot}	max.	60 mW
Storage temperature	T_{stg}		-55 to + 100 °C
Junction temperature	T_j	max.	100 °C
Lead soldering temperature			
> 3 mm from the seating plane; $t_{sld} < 7$ s	T_{sld}	max.	230 °C

THERMAL RESISTANCE

From junction to ambient

in free air

$R_{th\ j-a} = 0,75$ °C/mW

mounted on a printed-circuit board

$R_{th\ j-a} = 0,5$ °C/mW

CHARACTERISTICS

$T_j = 25$ °C unless otherwise specified

Forward voltage

$I_F = 10$ mA

V_F typ. 2,1 V
< 3 V

Reverse current

$V_R = 3$ V

I_R < 100 μ A

Diode capacitance

$V_R = 0$; $f = 1$ MHz

C_d typ. 35 pF

→ Luminous intensity (on-axis)

$I_F = 10$ mA

CQY95	I_v	>	0,3 mcd
CQY95-I	I_v		0,7 to 1,6 mcd
CQY95-II	I_v		1,0 to 2,2 mcd
CQY95-III	I_v	>	1,6 mcd

Wavelength at peak emission

λ_{pk} typ. 560 nm

Bandwidth at half height

$B_{50\%}$ typ. 30 nm

Beamwidth between half-intensity directions

$\alpha_{50\%}$ typ. 60°

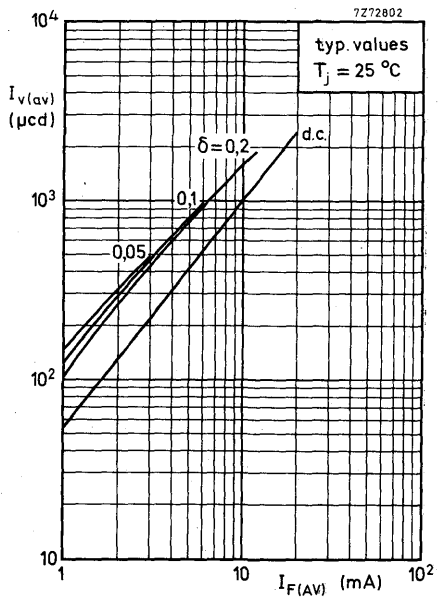
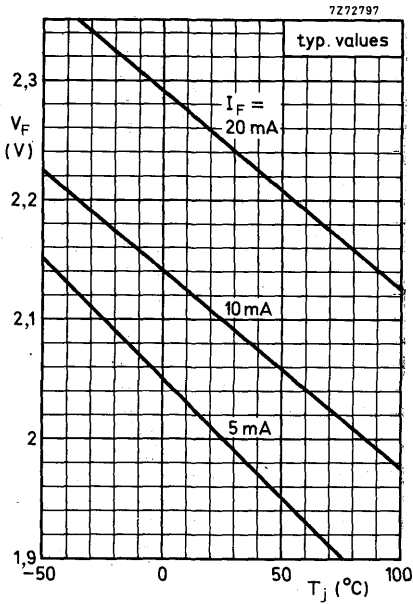
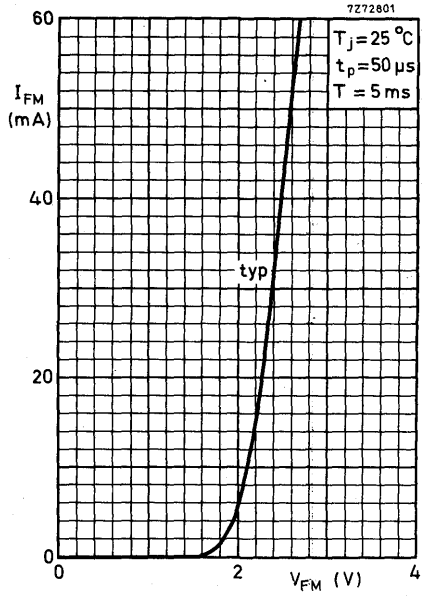
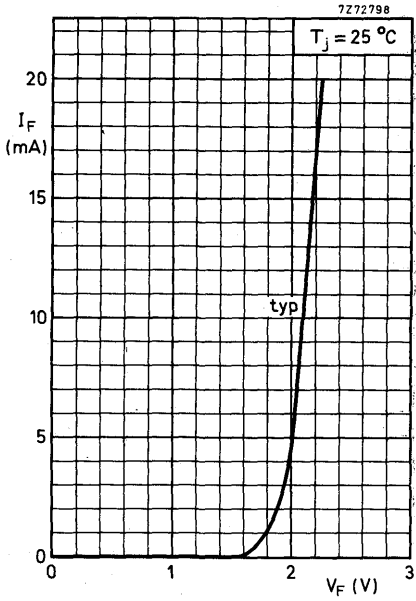

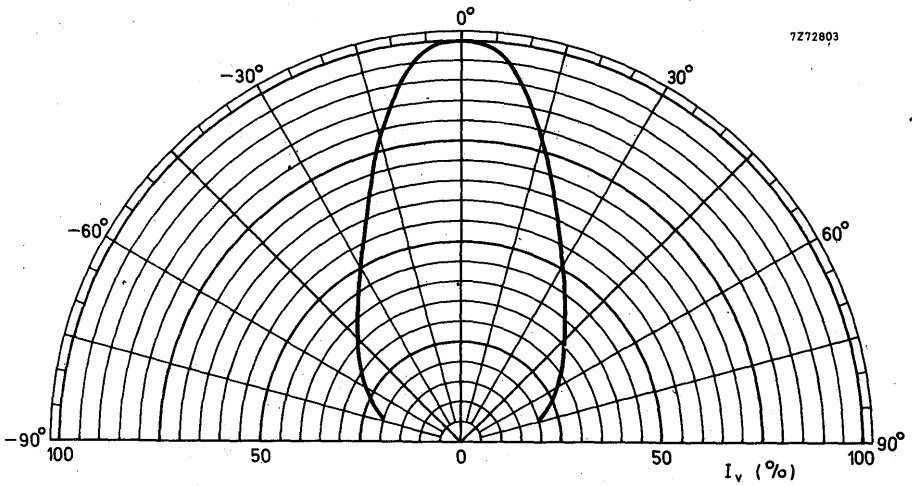
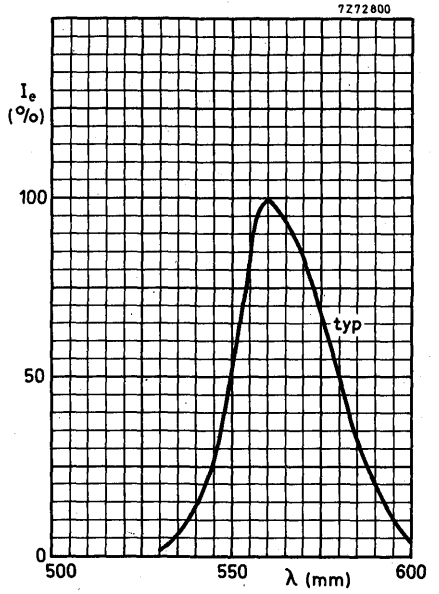
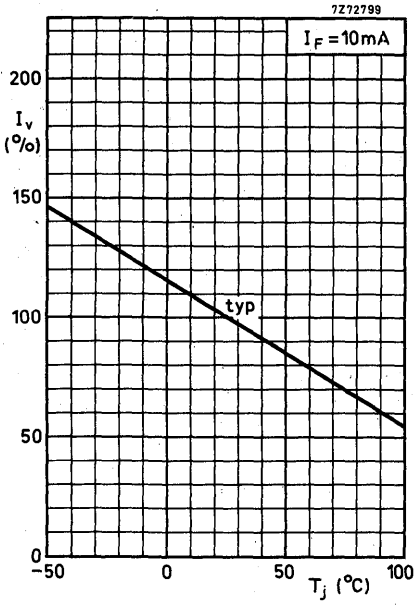

RATINGS

Limiting values in accordance with the Absolute Maximum System (IEC 134)

Continuous reverse voltage	V_R	max.	3 V
Forward current (d.c.)	I_F	max.	20 mA
Forward current (peak value)			
$t_p < 1$ ms; $f < 300$ Hz	I_{FM}	max.	60 mA
$t_p < 1$ μ s; $f < 300$ Hz	I_{FM}	max.	1000 mA
Total power dissipation up to $T_{amb} = 55$ °C	P_{tot}	max.	60 mW
Storage temperature	T_{stg}		-55 to + 100 °C
Junction temperature	T_j	max.	100 °C
Lead soldering temperature			
> 1,5 mm from the seating plane; $t_{sld} < 7$ s	T_{sld}	max.	230 °C

THERMAL RESISTANCE

From junction to ambient			
in free air	$R_{th\ j-a}$	=	0,75 °C/mW
mounted on a printed board	$R_{th\ j-a}$	=	0,5 °C/mW

CHARACTERISTICS

$T_j = 25$ °C unless otherwise specified

Forward voltage			
$I_F = 10$ mA	V_F	typ.	2,1 V
		<	3 V
Reverse current			
$V_R = 3$ V	I_R	<	100 μ A
Diode capacitance			
$V_R = 0$; $f = 1$ MHz	C_d	typ.	35 pF
→ Luminous intensity (on-axis)			
$I_F = 10$ mA	CQY96	I_v	> 0,5 mcd
	CQY96-I	I_v	0,7 to 1,6 mcd
	CQY96-II	I_v	1,0 to 2,2 mcd
	CQY96-III	I_v	> 1,6 mcd
Wavelength at peak emission		λ_{pk}	typ. 590 nm
Bandwidth at half height		$B_{50\%}$	typ. 38 nm
Beamwidth between half-intensity directions		$\alpha_{50\%}$	typ. 60°

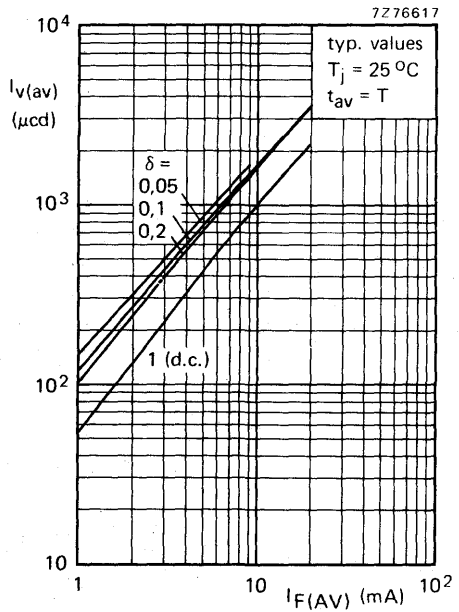
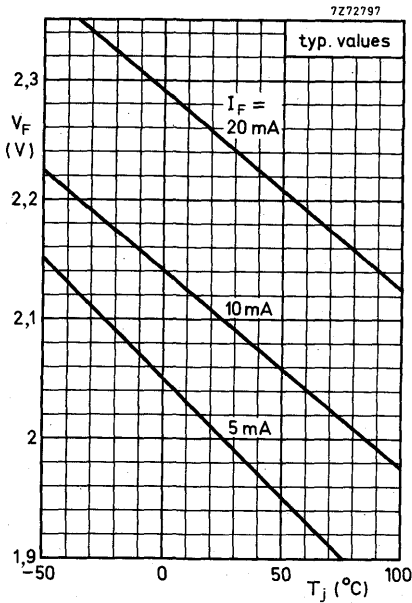
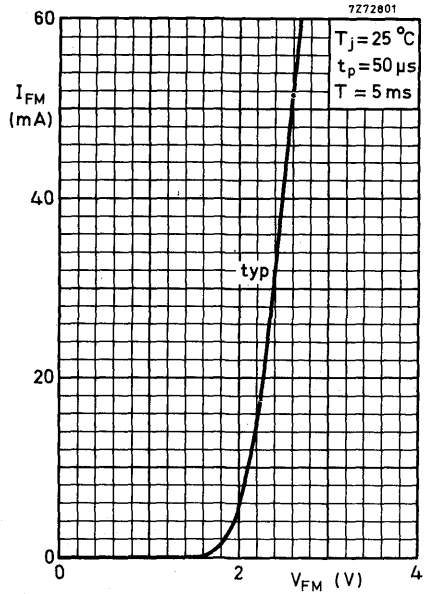
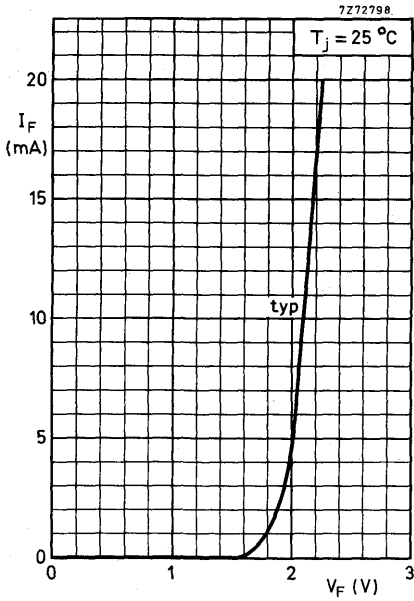

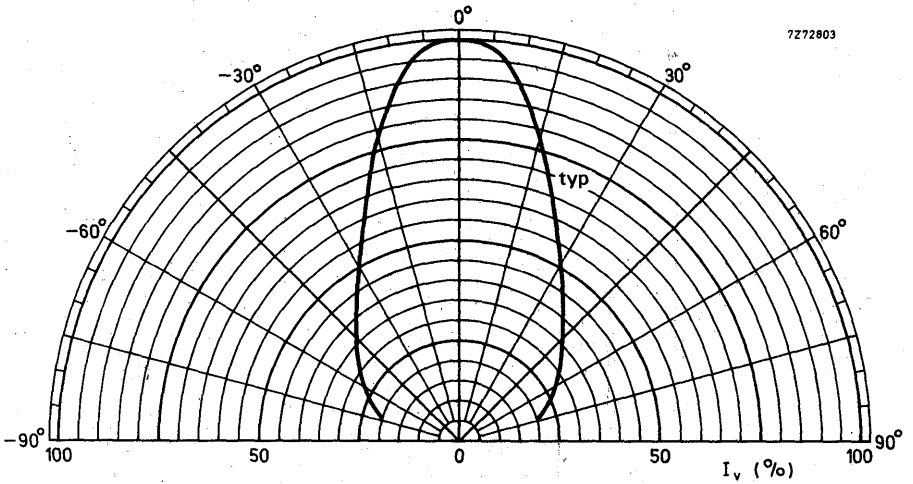
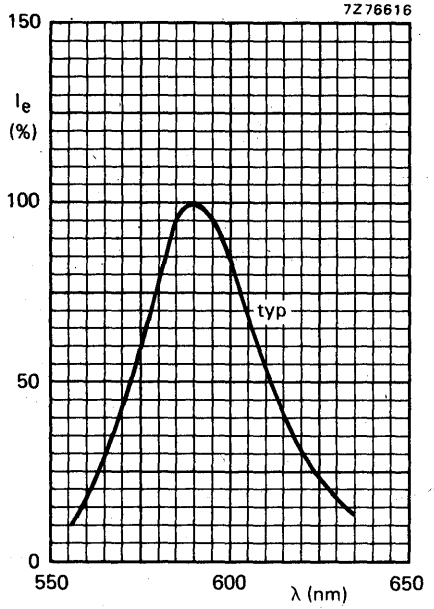
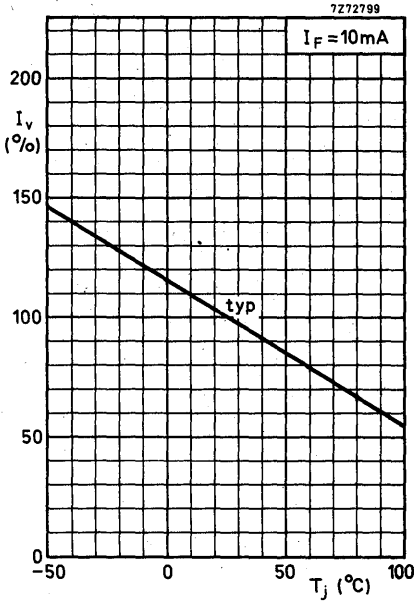

GaAsP YELLOW LIGHT EMITTING DIODE

Gallium arsenide phosphide light emitting diode which emits yellow light when forward biased.
 Yellow, light-diffusing plastic envelope.

QUICK REFERENCE DATA

Continuous reverse voltage	V_R	max.	3 V
Forward current (d.c.)	I_F	max.	20 mA
Total power dissipation up to $T_{amb} = 55^\circ C$	P_{tot}	max.	60 mW
Luminous intensity (on-axis) at $I_F = 10$ mA	CQY97	I_v	> 0,3 mcd
	CQY97-I	I_v	0,7 to 1,6 mcd
	CQY97-II	I_v	1,0 to 2,2 mcd
	CQY97-III	I_v	> 1,6 mcd
Wavelength at peak emission	λ_{pk}	typ.	590 nm
Beamwidth between half-intensity directions	$\alpha_{50\%}$	typ.	60°

MECHANICAL DATA

Dimensions in mm

Fig. 1 SOD-53C.

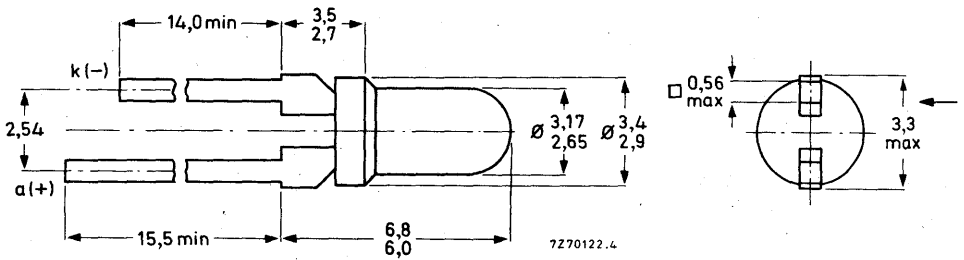

RATINGS

Limiting values in accordance with the Absolute Maximum System (IEC 134)

Continuous reverse voltage	V_R	max.	3 V
Forward current (d.c.)	I_F	max.	20 mA
Forward current (peak value)			
$t_p < 1 \text{ ms}; f < 300 \text{ Hz}$	I_{FM}	max.	60 mA
$t_p < 1 \text{ } \mu\text{s}; f < 300 \text{ Hz}$	I_{FM}	max.	1000 mA
Total power dissipation up to $T_{amb} = 55 \text{ }^\circ\text{C}$	P_{tot}	max.	60 mW
Storage temperature	T_{stg}		-55 to + 100 $^\circ\text{C}$
Junction temperature	T_j	max.	100 $^\circ\text{C}$
Lead soldering temperature			
> 3 mm from the seating plane; $t_{sld} < 7 \text{ s}$	T_{sld}	max.	230 $^\circ\text{C}$

THERMAL RESISTANCE

From junction to ambient			
in free air	$R_{th \text{ j-a}}$	=	0,75 $^\circ\text{C}/\text{mW}$
mounted on a printed board	$R_{th \text{ j-a}}$	=	0,5 $^\circ\text{C}/\text{mW}$

CHARACTERISTICS

$T_j = 25 \text{ }^\circ\text{C}$ unless otherwise specified

Forward voltage			
$I_F = 10 \text{ mA}$	V_F	typ.	2,1 V
		<	3 V
Reverse current			
$V_R = 3 \text{ V}$	I_R	<	100 μA
Diode capacitance			
$V_R = 0; f = 1 \text{ MHz}$	C_d	typ.	35 pF
→ Luminous intensity (on-axis)			
$I_F = 10 \text{ mA}$	CQY97	I_v	> 0,3 mcd
	CQY97-I	I_v	0,7 to 1,6 mcd
	CQY97-II	I_v	1,0 to 2,2 mcd
	CQY97-III	I_v	> 1,6 mcd
Wavelength at peak emission		λ_{pk}	typ. 590 nm
Bandwidth at half height		$B_{50\%}$	typ. 38 nm
Beamwidth between half-intensity directions		$\alpha_{50\%}$	typ. 60 $^\circ$

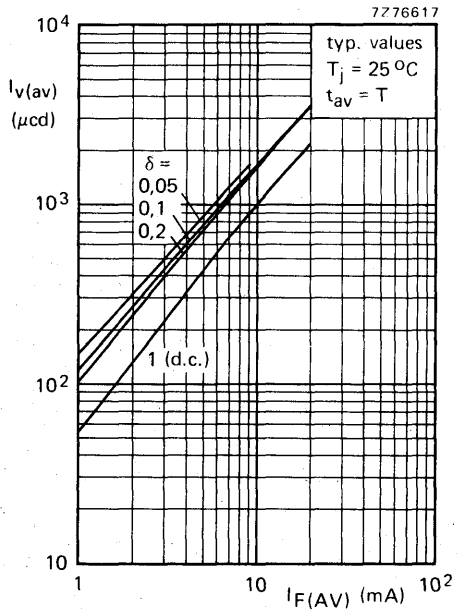
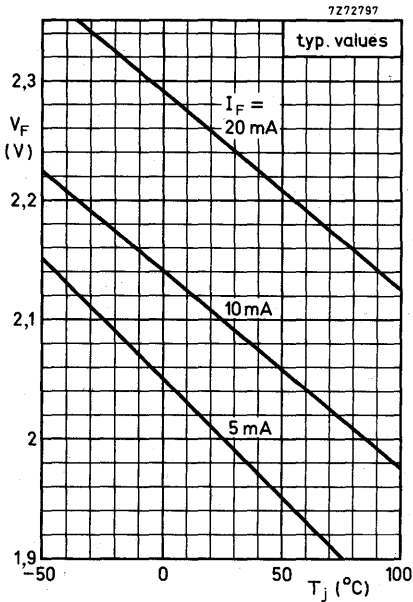
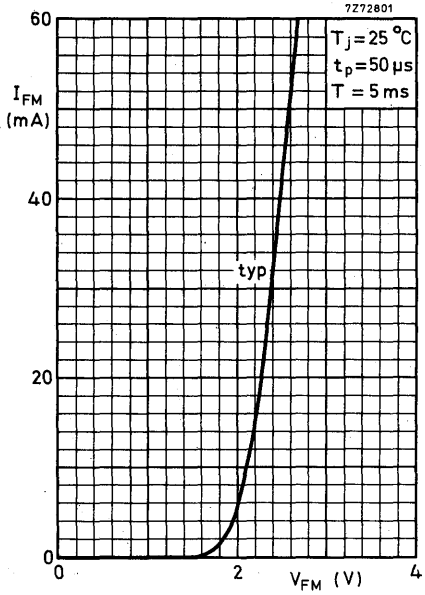
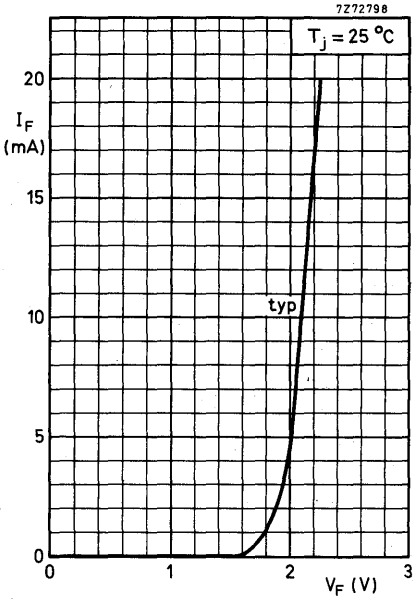

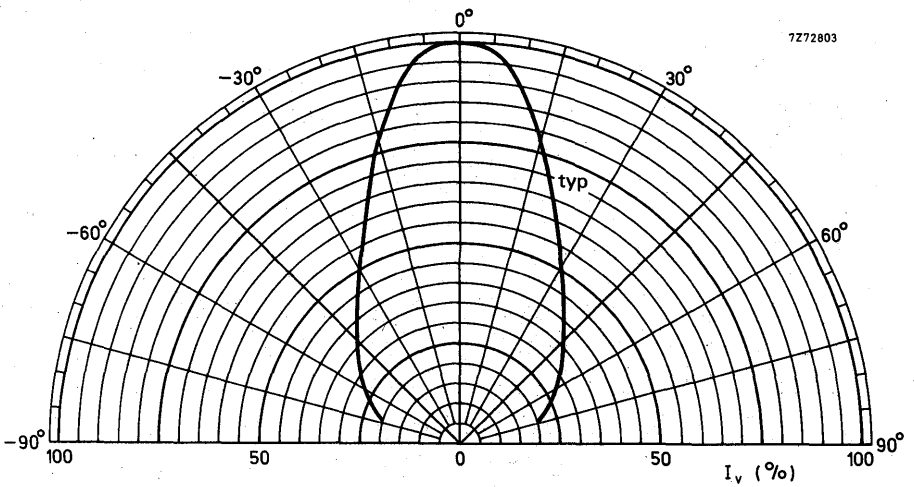
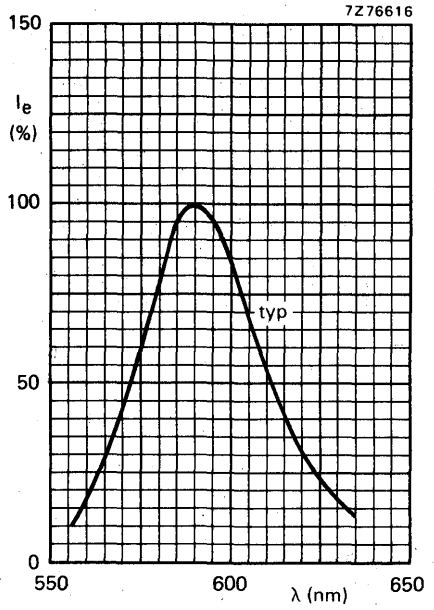
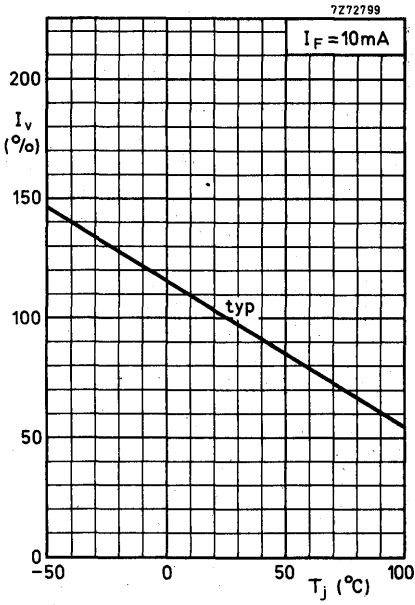

PHOTOCOUPERS



PHOTOCOUPLERS

Optically coupled isolators consisting of an infrared emitting GaAs diode and a silicon n-p-n phototransistor. Plastic envelopes. Suitable for TTL integrated circuits. The CNY22 is the 5 pin version with an accessible transistor base; the CNY42 is the 4 pin version without accessible base.

QUICK REFERENCE DATA

Diode

Reverse voltage	V_R	max.	2 V
Forward current (d. c.)	I_F	max.	30 mA
Forward current (peak value)	I_{FM}	max.	200 mA
Total power dissipation up to $T_{amb} = 65\text{ }^\circ\text{C}$	P_{tot}	max.	50 mW

Transistor

Collector-emitter voltage (open base)	V_{CEO}	max.	50 V
Collector cut-off current (dark) $V_{CE} = 10\text{ V}$; diode: $I_F = 0$	I_{CEO}	<	100 nA
Total power dissipation up to $T_{amb} = 25\text{ }^\circ\text{C}$	P_{tot}	max.	200 mW

Photocoupler

Output/input d. c. current transfer ratio $I_F = 8\text{ mA}$; $V_{CE} = 5\text{ V}$; ($I_B = 0$)	I_C/I_F	>	0,25
Collector-emitter saturation voltage $I_F = 8\text{ mA}$; $I_C = 2\text{ mA}$; ($I_B = 0$)	V_{CEsat}	<	0,4 V
Isolation voltage, r. m. s. value	$V_{IO(RMS)}$	>	2800 V

MECHANICAL DATA See page 2.

CNY22 CNY42

MECHANICAL DATA

Dimensions in mm

CNY22

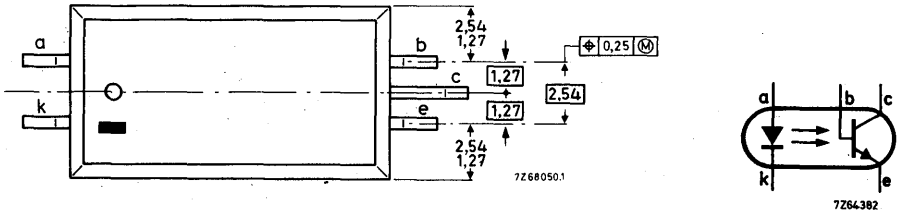
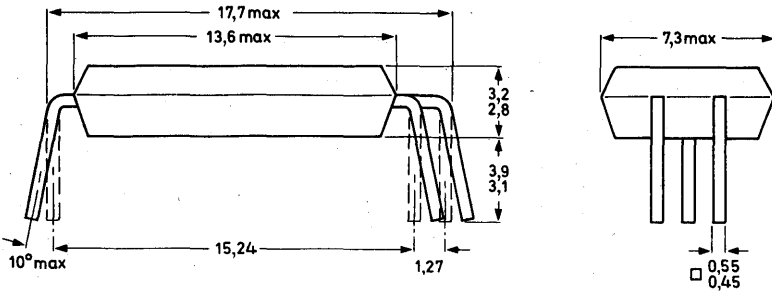

7264382

CNY42

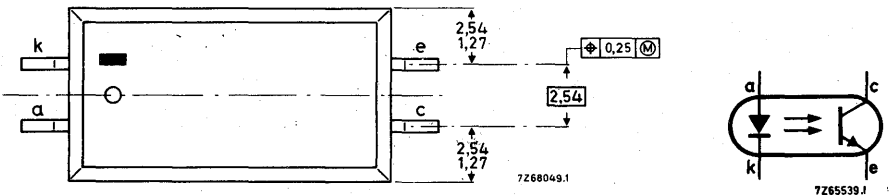
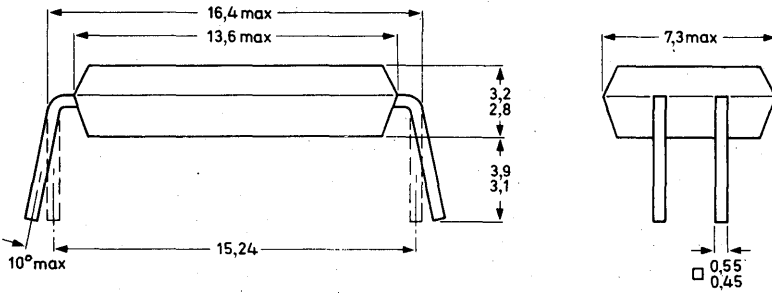

7265539.1

RATINGS Limiting values in accordance with the Absolute Maximum System (IEC 134)

Diode

Reverse voltage	V_R	max.	2 V
Forward current (d. c.)	I_F	max.	30 mA
Forward current (peak value)	I_{FM}	max.	200 mA
Total power dissipation up to $T_{amb} = 65\text{ }^\circ\text{C}$	P_{tot}	max.	50 mW
Junction temperature	T_j	max.	125 $^\circ\text{C}$

Transistor

Collector-emitter voltage (open base)	V_{CEO}	max.	50 V
Collector-base voltage (open emitter) (CNY22)	V_{CBO}	max.	50 V
Emitter-collector voltage (open base)	V_{ECO}	max.	6 V
Collector current (d. c.)	I_C	max.	30 mA
Total power dissipation up to $T_{amb} = 25\text{ }^\circ\text{C}$	P_{tot}	max.	200 mW
Junction temperature	T_j	max.	125 $^\circ\text{C}$

Photocoupler

Storage temperature	T_{stg}	-55 to +125 $^\circ\text{C}$
---------------------	-----------	------------------------------

THERMAL RESISTANCE

From junction to ambient in free air		
-diode	$R_{th\ j-a}$	1,2 $^\circ\text{C}/\text{mW}$
-transistor	$R_{th\ j-a}$	0,5 $^\circ\text{C}/\text{mW}$



CHARACTERISTICS

$T_j = 25\text{ }^\circ\text{C}$ unless otherwise specified

Diode

Forward voltage, $I_F = 8\text{ mA}$

V_F	typ.	1, 2	V
	<	1, 6	V

Reverse current, $V_R = 2\text{ V}$

I_R	<	100	μA
-------	---	-----	---------------

Transistor ($I_B = 0$)

Collector cut-off current (dark)

$V_{CE} = 10\text{ V}$; diode: $I_F = 0$

I_{CEO}	<	100	nA
	typ.	5	nA

Photocoupler ($I_B = 0$)¹⁾

Output/input d.c. current transfer ratio

$I_F = 8\text{ mA}$; $V_{CE} = 5\text{ V}$

I_C/I_F	>	0, 25	2), 3)
	typ.	0, 5	

Collector-emitter saturation voltage

$I_F = 8\text{ mA}$; $I_C = 2\text{ mA}$; $T_{amb} = 25\text{ }^\circ\text{C}$

V_{CEsat}	typ.	0, 17	V
	<	0, 4	V

Isolation voltage, r. m. s. value

$V_{IO(RMS)}$	>	2800	V ⁴⁾
---------------	---	------	-----------------

Capacitance between input and output

$I_F = 0$; $V = 0$; $f = 1\text{ MHz}$

C_{io}	typ.	1	pF
----------	------	---	----

Insulation resistance between input and output

$V_{IO} = 1000\text{ V}$

r_{IO}	>	10^{10}	Ω
	typ.	10^{12}	Ω

Turn-on time (circuit below)

$I_{CM} = 2\text{ mA}$; $V_{CC} = 5\text{ V}$; $R_L = 100\text{ }\Omega$

t_{on}	typ.	5	μs
----------	------	---	---------------

Turn-off time (circuit below)

$I_{CM} = 2\text{ mA}$; $V_{CC} = 5\text{ V}$; $R_L = 100\text{ }\Omega$

t_{off}	typ.	5	μs
-----------	------	---	---------------

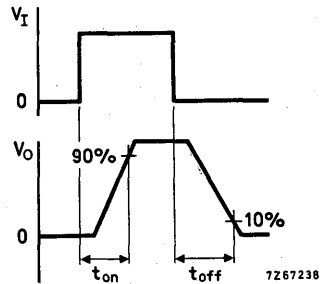
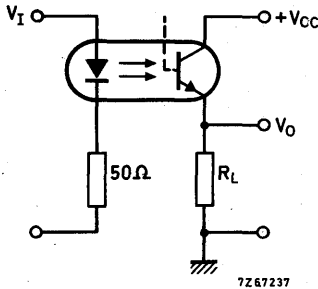

Data on V_I :

$t_r = t_f = 20\text{ ns}$

$t_p = 30\text{ }\mu\text{s}$

$f = 500\text{ Hz}$

- 1) Where the phototransistor receives light from the diode the O (for open base) has been omitted from the symbols.
- 2) Measured with pulses: $t_p = 100\text{ }\mu\text{s}$; $T = 1\text{ ms}$.
- 3) Aging of the light-emitting diode decreases the transfer ratio at a rate proportional to current and operating time. In circuits that operate for long periods, therefore, the duty factor of the couplers should be kept as low as possible. This can often be done with the aid of an inverter.
- 4) Tested with a 50 Hz a.c. voltage for 1 minute between shorted input leads and shorted output leads.

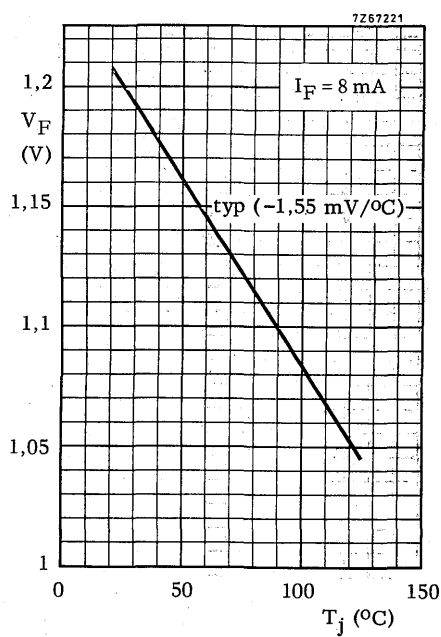
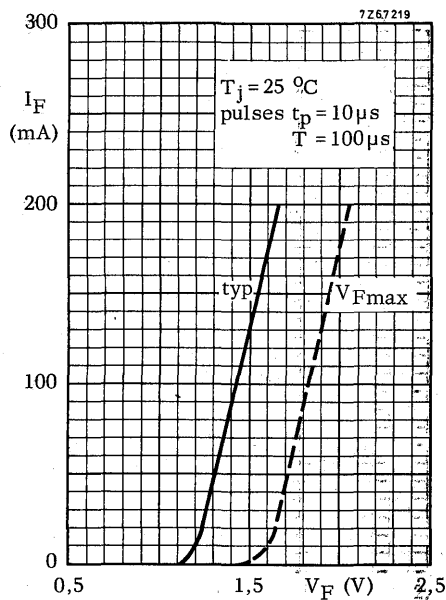
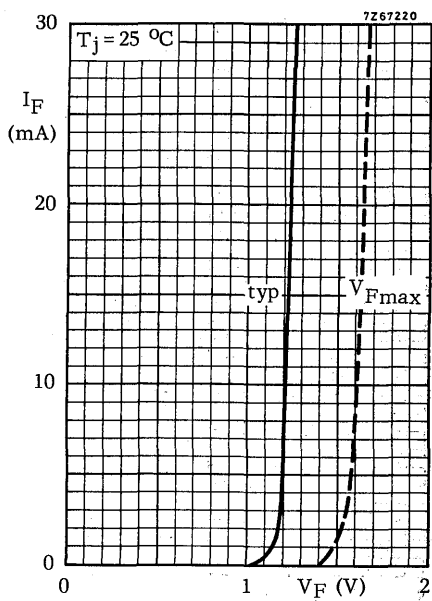
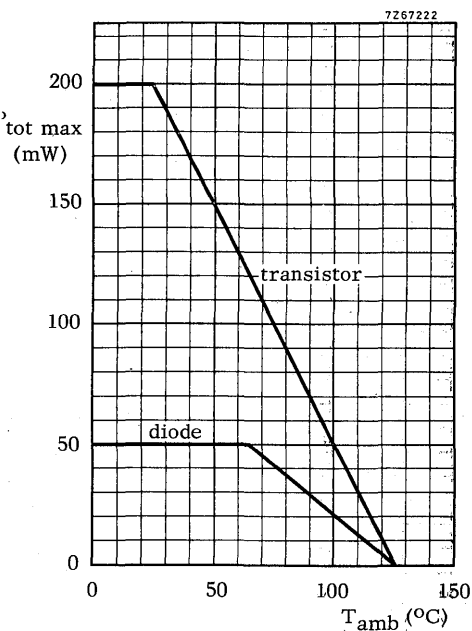

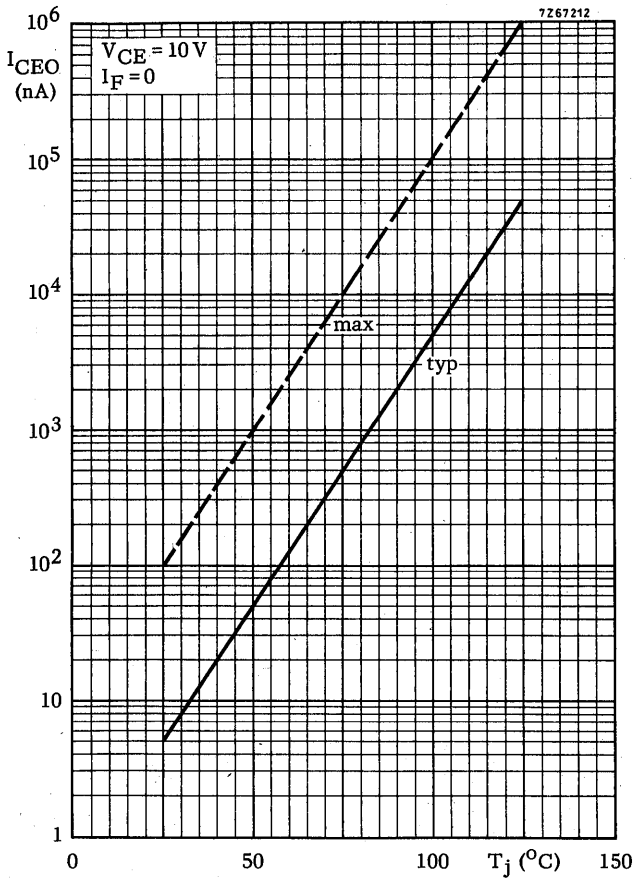

7267228

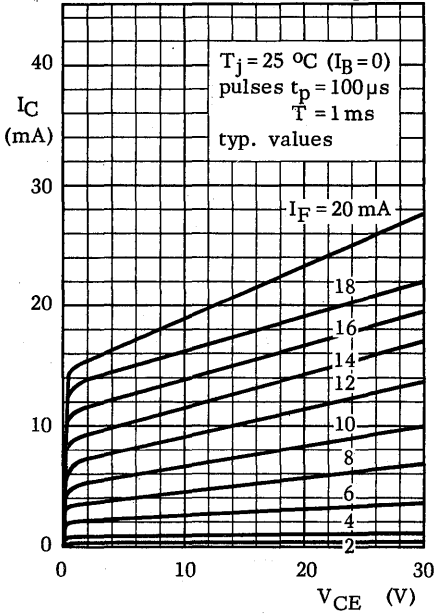

7267226

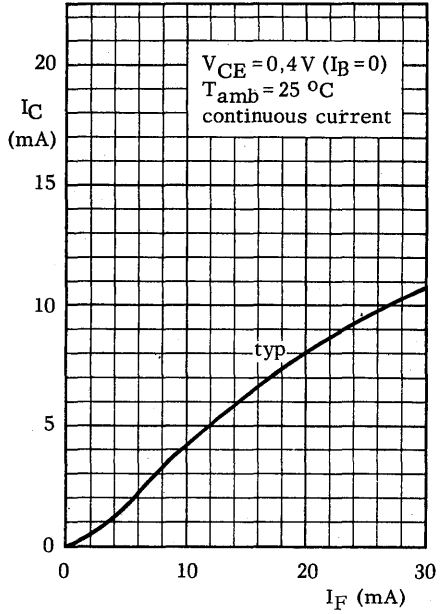

7267224

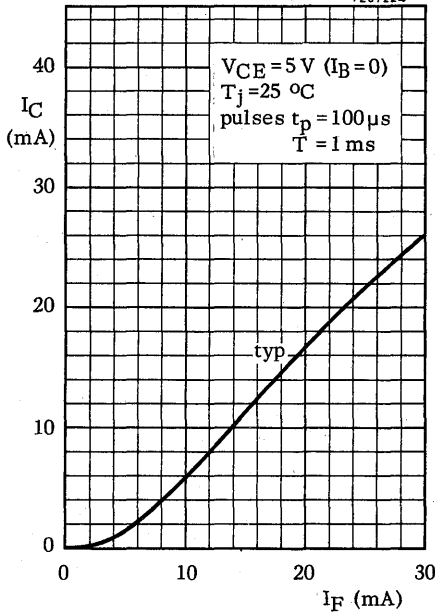

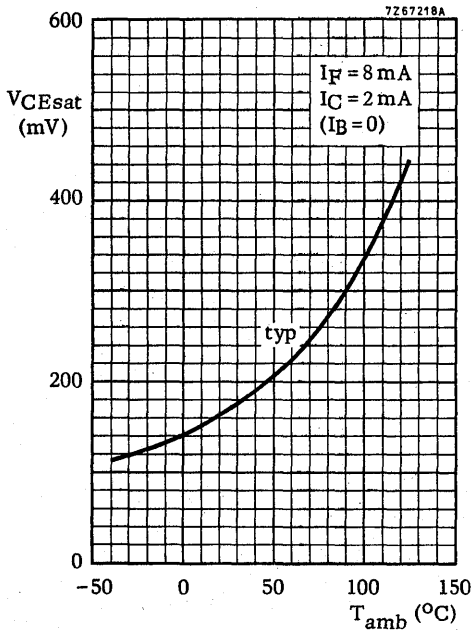
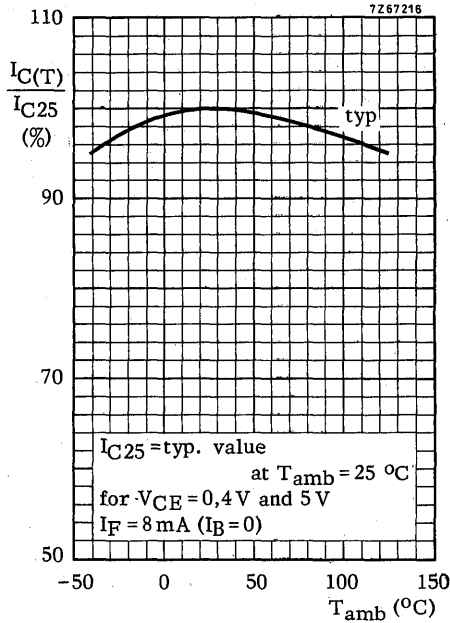

PHOTOCOUPLERS

Optically coupled isolators consisting of an infrared emitting GaAs diode and a silicon n-p-n phototransistor. Plastic envelopes. Suitable for TTL integrated circuits. The CNY23 is the 5 pin version with an accessible transistor base; the CNY43 is the 4 pin version without accessible base.

QUICK REFERENCE DATA

Diode

Reverse voltage	V_R	max.	2 V
Forward current (d. c.)	I_F	max.	30 mA
Forward current (peak value)	I_{FM}	max.	200 mA
Total power dissipation up to $T_{amb} = 65\text{ }^\circ\text{C}$	P_{tot}	max.	50 mW

Transistor

Collector-emitter voltage (open base)	V_{CEO}	max.	30 V
Collector cut-off current (dark) $V_{CE} = 10\text{ V}$; diode: $I_F = 0$	I_{CEO}	<	100 nA
Total power dissipation up to $T_{amb} = 25\text{ }^\circ\text{C}$	P_{tot}	max.	200 mW

Photocoupler

Output/input d. c. current transfer ratio $I_F = 8\text{ mA}$; $V_{CE} = 5\text{ V}$; ($I_B = 0$)	I_C / I_F	>	0,5
Collector-emitter saturation voltage $I_F = 8\text{ mA}$; $I_C = 4\text{ mA}$; ($I_B = 0$)	V_{CEsat}	<	0,4 V
Isolation voltage, r.m.s. value	$V_{IO(RMS)}$	>	2000 V

MECHANICAL DATA See page 2.

CNY23
CNY43

MECHANICAL DATA

Dimensions in mm

CNY23

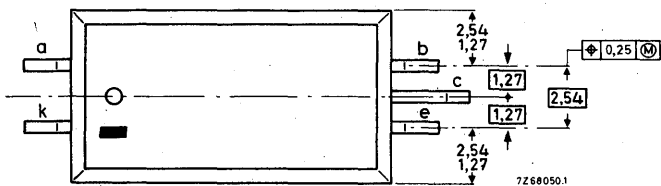
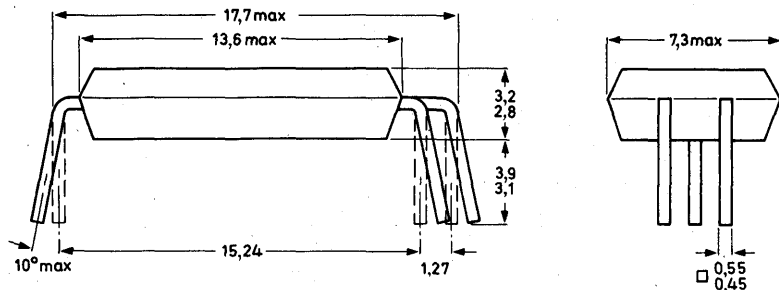

7268050.1

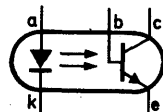

7264382

CNY43

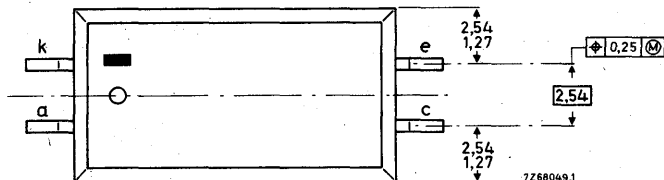
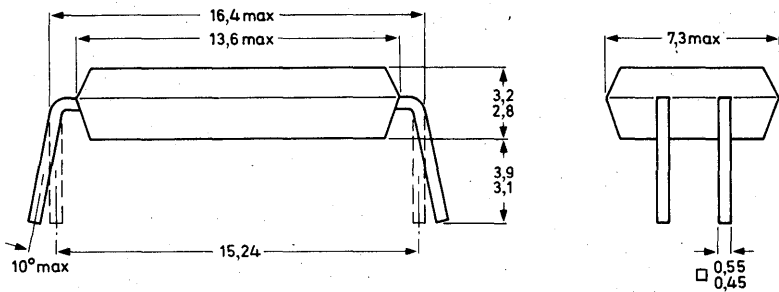

7268049.1

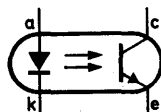

7265539.1

RATINGS Limiting values in accordance with the Absolute Maximum System (IEC 134)

Diode

Reverse voltage	V_R	max.	2 V
Forward current (d. c.)	I_F	max.	30 mA
Forward current (peak value)	I_{FM}	max.	200 mA
Total power dissipation up to $T_{amb} = 65^\circ C$	P_{tot}	max.	50 mW
Junction temperature	T_j	max.	125 $^\circ C$

Transistor

Collector-emitter voltage (open base)	V_{CEO}	max.	30 V
Collector-base voltage (open emitter) (CNY23)	V_{CBO}	max.	40 V
Emitter-collector voltage (open base)	V_{ECO}	max.	6 V
Collector current (d. c.)	I_C	max.	30 mA
Total power dissipation up to $T_{amb} = 25^\circ C$	P_{tot}	max	200 mW
Junction temperature	T_j	max.	125 $^\circ C$

Photocoupler

Storage temperature	T_{stg}	-55 to +125 $^\circ C$
---------------------	-----------	------------------------

THERMAL RESISTANCE

From junction to ambient in free air		
-diode	$R_{th\ j-a}$	1, 2 $^\circ C/mW$
-transistor	$R_{th\ j-a}$	0, 5 $^\circ C/mW$



CHARACTERISTICS

$T_j = 25\text{ }^\circ\text{C}$ unless otherwise specified

Diode

Forward voltage, $I_F = 8\text{ mA}$

V_F	typ.	1,2	V
	<	1,6	V

Reverse current, $V_R = 2\text{ V}$

I_R	<	100	μA
-------	---	-----	---------------

Transistor ($I_B = 0$)

Collector cut-off current (dark)

$V_{CE} = 10\text{ V}$; diode: $I_F = 0$

I_{CEO}	<	100	nA
	typ.	5	nA

Photocoupler ($I_B = 0$)¹⁾

Output/input d. c. current transfer ratio

$I_F = 8\text{ mA}$; $V_{CE} = 5\text{ V}$

I_C/I_F	>	0,5	2) 3)
	typ.	1	

Collector-emitter saturation voltage

$I_F = 8\text{ mA}$; $I_C = 4\text{ mA}$; $T_{amb} = 25\text{ }^\circ\text{C}$

V_{CEsat}	typ.	0,17	V
	<	0,4	V

Isolation voltage, r. m. s. value

$V_{IO(RMS)}$	>	2000	V ⁴⁾
---------------	---	------	-----------------

Capacitance between input and output

$I_F = 0$; $V = 0$; $f = 1\text{ MHz}$

C_{io}	typ.	1	pF
----------	------	---	----

Insulation resistance between input and output

$V_{IO} = 1000\text{ V}$

r_{IO}	>	10^{10}	Ω
	typ.	10^{12}	Ω

Turn-on time (circuit below)

$I_{CM} = 4\text{ mA}$; $V_{CC} = 5\text{ V}$; $R_L = 100\text{ }\Omega$

t_{on}	typ.	5	μs
----------	------	---	---------------

Turn-off time (circuit below)

$I_{CM} = 4\text{ mA}$; $V_{CC} = 5\text{ V}$; $R_L = 100\text{ }\Omega$

t_{off}	typ.	5	μs
-----------	------	---	---------------

Data on V_I :
 $t_r = t_f = 20\text{ ns}$
 $t_p = 30\text{ }\mu\text{s}$
 $f = 500\text{ Hz}$

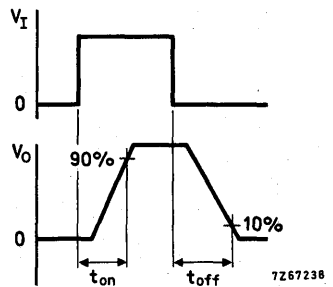
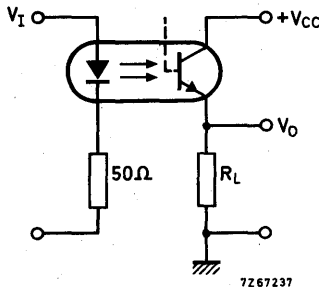

- 1) Where the phototransistor receives light from the diode the O (for open base) has been omitted from the symbols.
- 2) Measured with pulses: $t_p = 100\text{ }\mu\text{s}$; $T = 1\text{ ms}$.
- 3) Aging of the light-emitting diode decreases the transfer ratio at a rate proportional to current and operating time. In circuits that operate for long periods, therefore, the duty factor of the couplers should be kept as low as possible. This can often be done with the aid of an inverter.
- 4) Tested with a 50 Hz a. c. voltage for 1 minute between shorted input leads and shorted output leads.

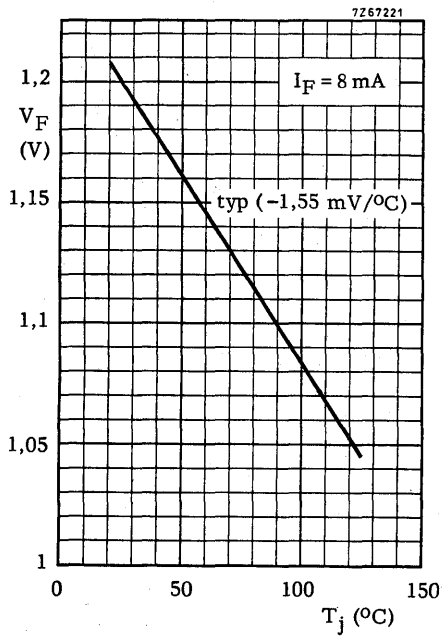
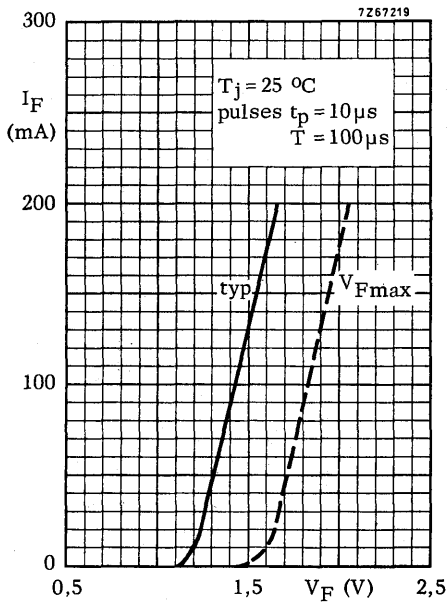
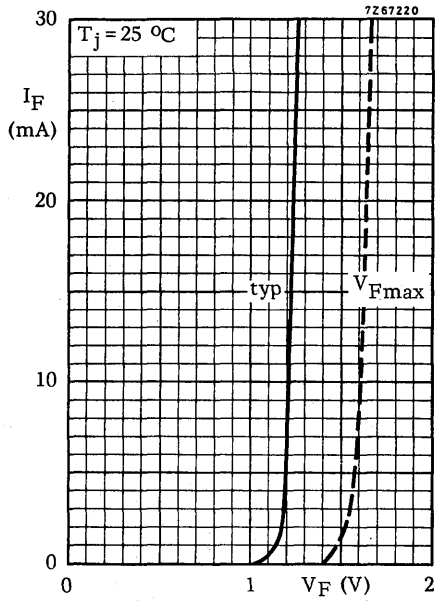
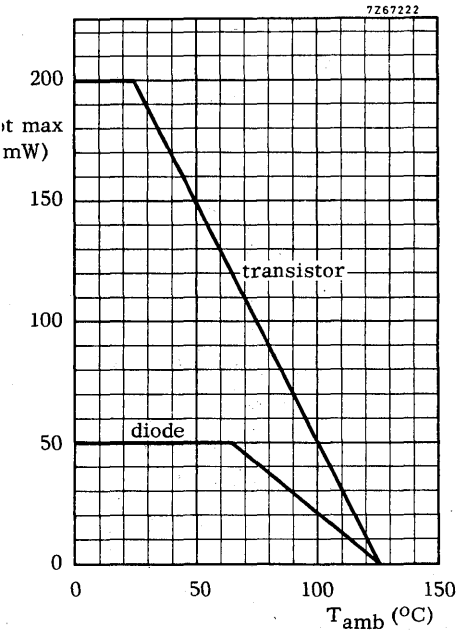

CNY23
CNY43

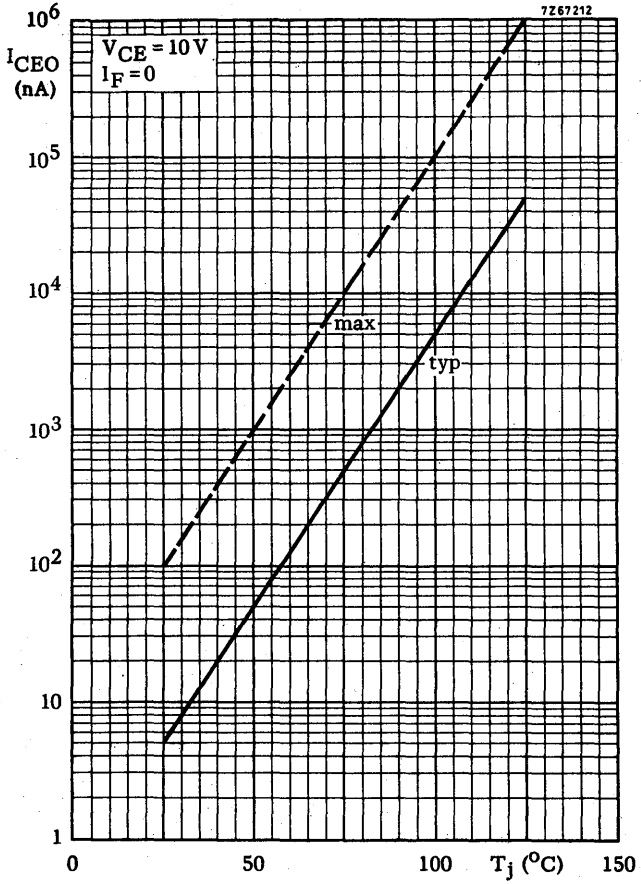

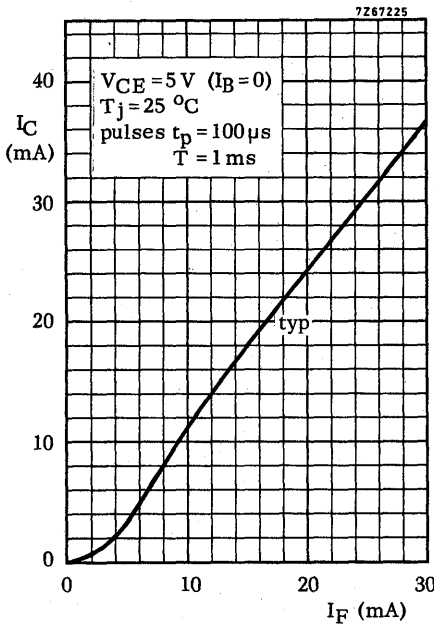
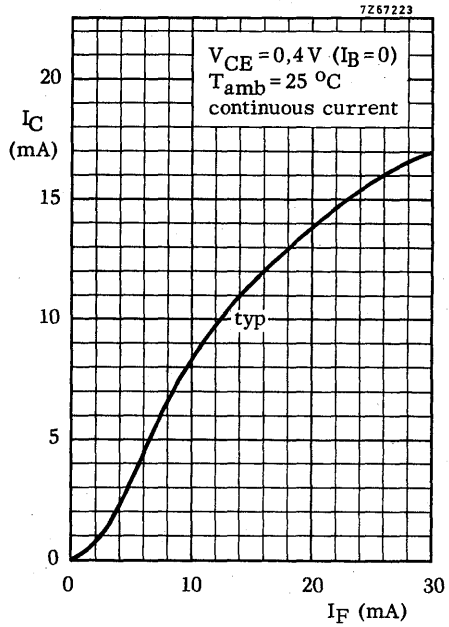
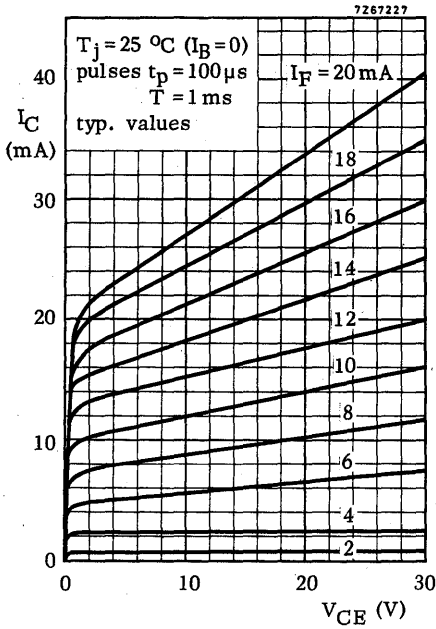

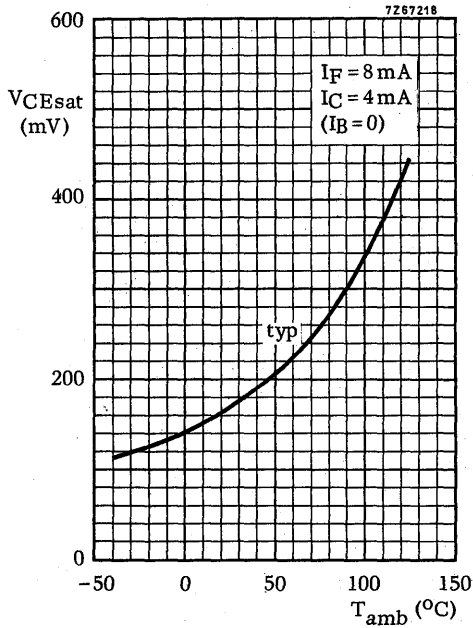
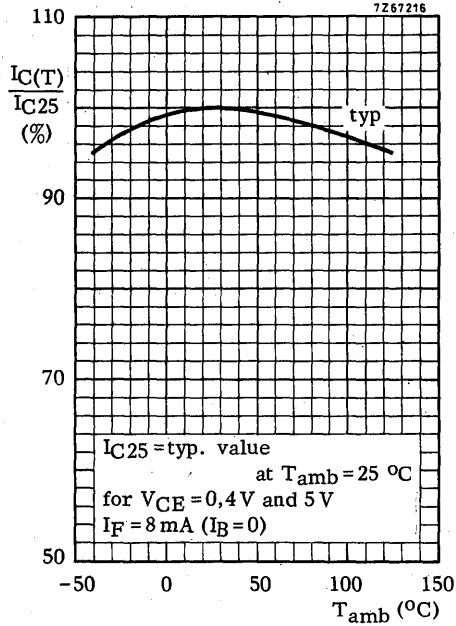

PHOTOCOUPLER

Optically coupled isolator consisting of an infra-red emitting GaAs diode and a silicon n-p-n phototransistor. TO-12 envelope. Suitable for TTL integrated circuits.

QUICK REFERENCE DATA

Diode

Continuous reverse voltage	V_R	max.	3 V
Forward current (d.c.)	I_F	max.	30 mA
Forward current (peak value)	I_{FM}	max.	200 mA
Total power dissipation up to $T_{amb} = 100\text{ }^\circ\text{C}$	P_{tot}	max.	50 mW

Transistor

Collector-emitter voltage (open base)	V_{CEO}	max.	50 V
Collector cut-off current (dark) $V_{CE} = 15\text{ V}; I_F = 0$	I_{CEO}	<	100 nA
Total power dissipation up to $T_{amb} = 25\text{ }^\circ\text{C}$	P_{tot}	max.	80 mW

Photocoupler

Output/input d.c. current transfer ratio $I_F = 10\text{ mA}; V_{CE} = 10\text{ V}$	I_C/I_F	>	0,3
Collector-emitter saturation voltage $I_F = 10\text{ mA}; I_C = 3\text{ mA}$	V_{CEsat}	<	0,4 V
Isolation voltage, r.m.s. value	$V_{IO(RMS)}$	>	1000 V

MECHANICAL DATA

Dimensions in mm

TO-12

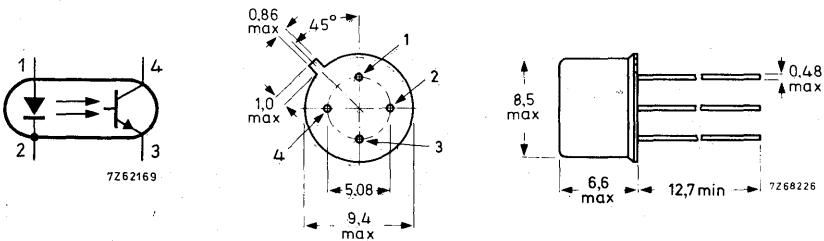

Cathode (2) connected to case

Max. lead diameter is guaranteed only for 12,7 mm.



RATINGS Limiting values in accordance with the Absolute Maximum System (IEC 134)

Diode

Continuous reverse voltage	V_R	max.	3	V
Forward current (d. c.)	I_F	max.	30	mA
Forward current (peak value)	I_{FM}	max.	200	mA
Total power dissipation up to $T_{amb} = 100\text{ }^\circ\text{C}$	P_{tot}	max.	50	mW
Junction temperature	T_j	max.	125	$^\circ\text{C}$

Transistor

Collector-emitter voltage (open base)	V_{CEO}	max.	50	V
Emitter-collector voltage (open base)	V_{ECO}	max.	8	V
Collector current (d. c.)	I_C	max.	30	mA
Collector current (peak value)	I_{CM}	max.	40	mA
Total power dissipation up to $T_{amb} = 25\text{ }^\circ\text{C}$	P_{tot}	max.	80	mW
Junction temperature	T_j	max	125	$^\circ\text{C}$

Photocoupler

Storage temperature	T_{stg}	-55 to +125	$^\circ\text{C}$
Solder temperature ($t < 10\text{ s}$)	T	max.	260 $^\circ\text{C}$

THERMAL RESISTANCE

From junction to ambient in free air			
- diode	$R_{th\ j-a}$	0,5	$^\circ\text{C}/\text{mW}$
- transistor	$R_{th\ j-a}$	1,2	$^\circ\text{C}/\text{mW}$
From junction to case, diode	$R_{th\ j-c}$	0,15	$^\circ\text{C}/\text{mW}$

CHARACTERISTICS

$T_j = 25\text{ }^\circ\text{C}$ unless otherwise specified

Diode

Forward voltage, $I_F = 10\text{ mA}$	V_F	typ.	1 to 1,5	V
			1,2	V
$I_F = 30\text{ mA}$	V_F	typ.	1,3	V
		<	1,6	V
$I_F = 200\text{ mA}$	V_F	typ.	1,5	V
Reverse current, $V_R = 3\text{ V}$	I_R	<	20	μA
Diode capacitance, $f = 1\text{ MHz}$; $V = 0$	C_d	typ.	50	pF

Transistor

Collector cut-off current (dark) at $I_F = 0$ $V_{CE} = 5\text{ V}$	I_{CEO}	typ.	3	nA
$V_{CE} = 15\text{ V}$	I_{CEO}	typ.	10	nA
		<	100	nA
$V_{CE} = 15\text{ V}$; $T_j = 85\text{ }^\circ\text{C}$	I_{CEO}	typ.	10	μA
		<	100	μA

Photocoupler ¹⁾

Output/input d. c. current transfer ratio

$I_F = 10\text{ mA}$; $V_{CE} = 10\text{ V}$
 $t_p = 80\text{ }\mu\text{s}$; $T = 10\text{ ms}$

I_C/I_F	>	0,3	2)
	typ.	0,6	

Collector-emitter saturation voltage

$I_F = 10\text{ mA}$; $I_C = 3\text{ mA}$; $T_{amb} = 25\text{ }^\circ\text{C}$
 $I_F = 15\text{ mA}$; $I_C = 4,6\text{ mA}$; $T_{amb} = 25\text{ }^\circ\text{C}$

V_{CEsat}	<	0,4	V
V_{CEsat}	<	0,4	V

Forward voltage

for $I_C = 10\text{ }\mu\text{A}$; $V_{CE} = 10\text{ V}$

V_F	>	0,9	V
	typ.	1,0	V

Isolation voltage, r. m. s. value

$V_{IO(RMS)}$	>	1000	V ³⁾
---------------	---	------	-----------------

Insulation resistance between input and output

$V_{IO} = 500\text{ V}$

r_{IO}	>	10^{10}	Ω
	typ.	10^{11}	Ω

1) Where the phototransistor receives light from the diode, the O (for open base) has been omitted from the symbols.

2) Aging of the light-emitting diode reduces the transfer ratio at a rate proportional to current and operating time. In circuits that operate for long periods, therefore, the duty factor of the couplers should be kept as low as possible. This can often be done with the aid of an inverter.

3) Tested with a 50 Hz a. c. voltage for 1 minute between shorted input leads and shorted output leads.

CHARACTERISTICS (continued)

$T_j = 25\text{ }^\circ\text{C}$ unless otherwise specified

Rise time of output voltage (circuit below)

$I_{CM} = 2\text{ mA}$; $V_{CC} = 10\text{ V}$

t_r typ. 2 μs ¹⁾

Fall time of output voltage (circuit below)

$I_{CM} = 2\text{ mA}$; $V_{CC} = 10\text{ V}$

t_f typ. 2 μs ¹⁾

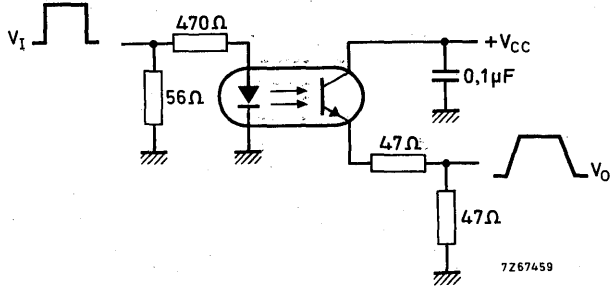

Data on V_I :
 $t_r = t_f = 20\text{ ns}$ ¹⁾
 $t_p = 30\text{ }\mu\text{s}$
 $f = 500\text{ Hz}$

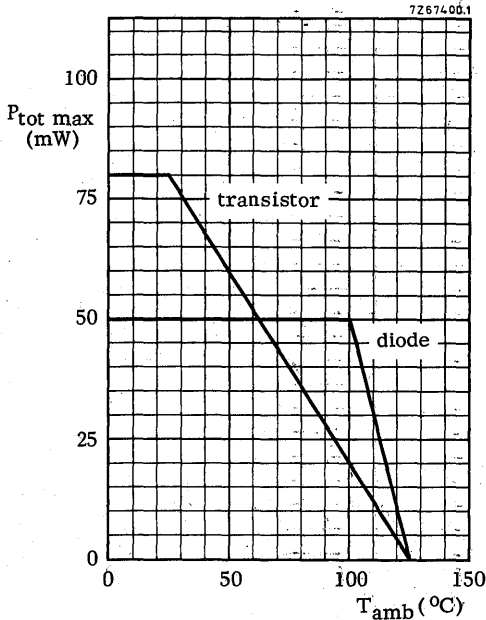

¹⁾ Between the 10% and 90% of the edges.

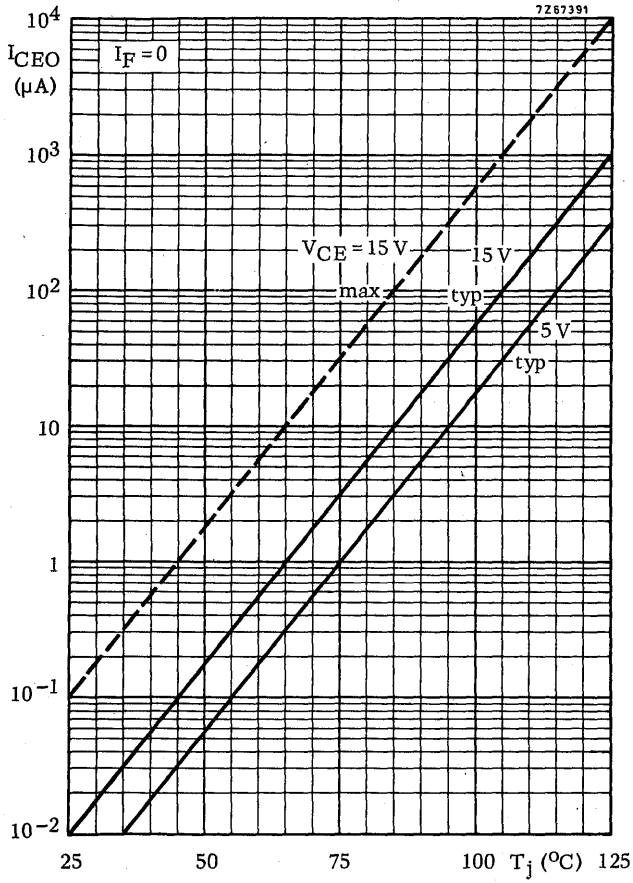

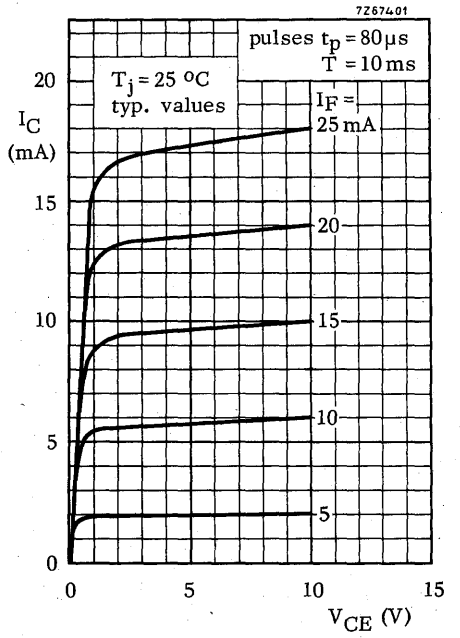
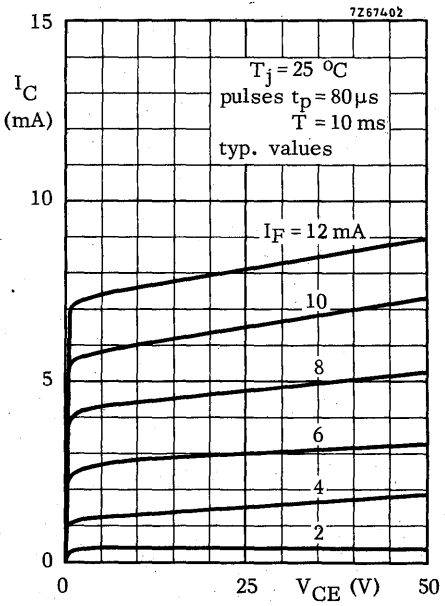
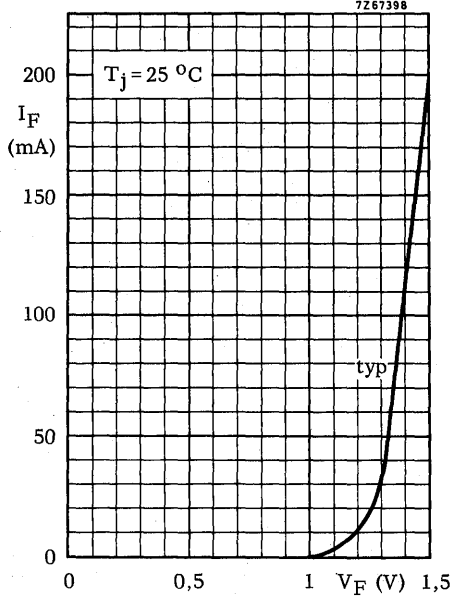
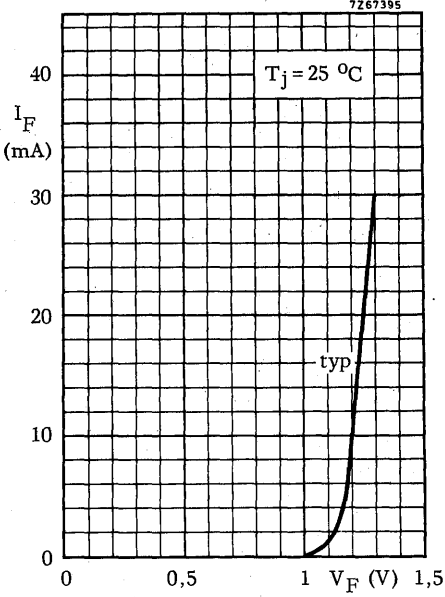

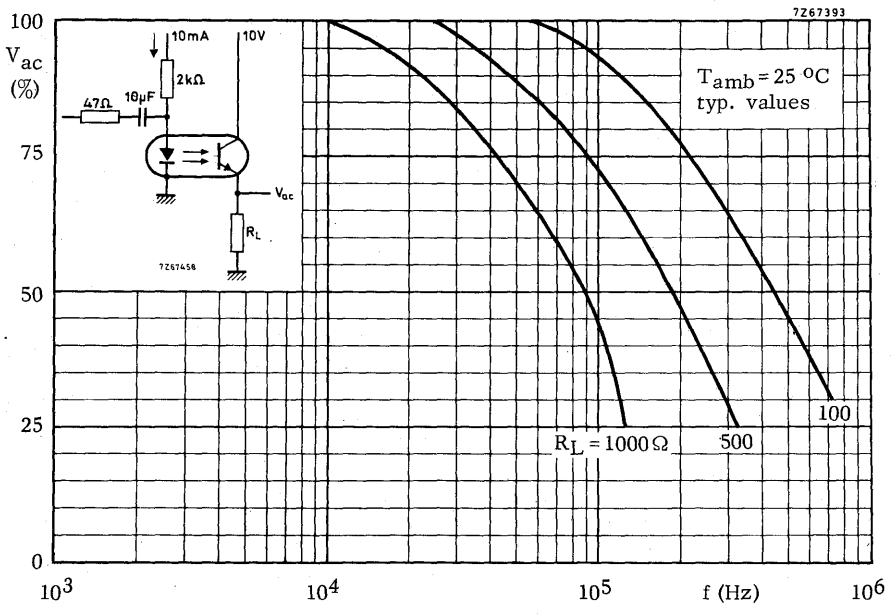
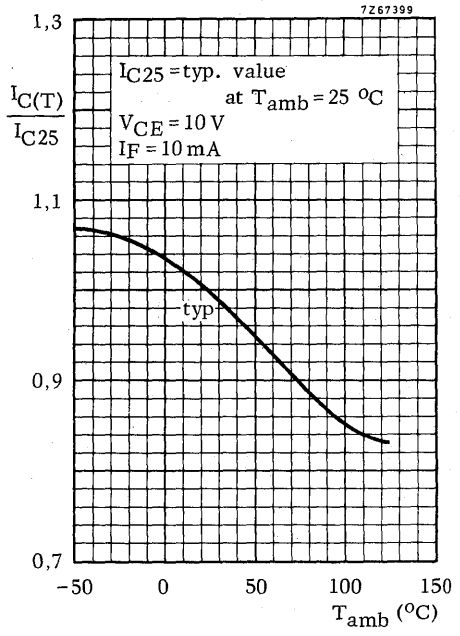
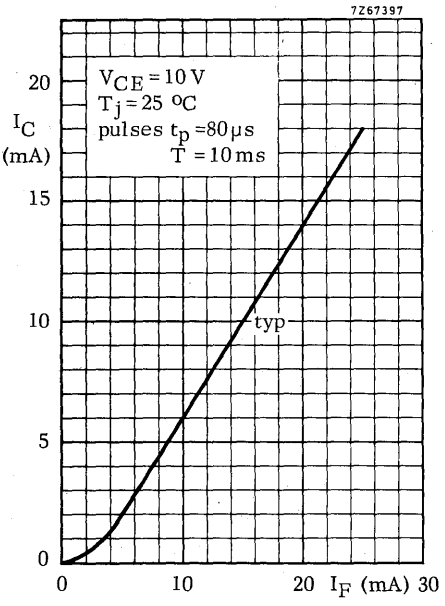

7267392

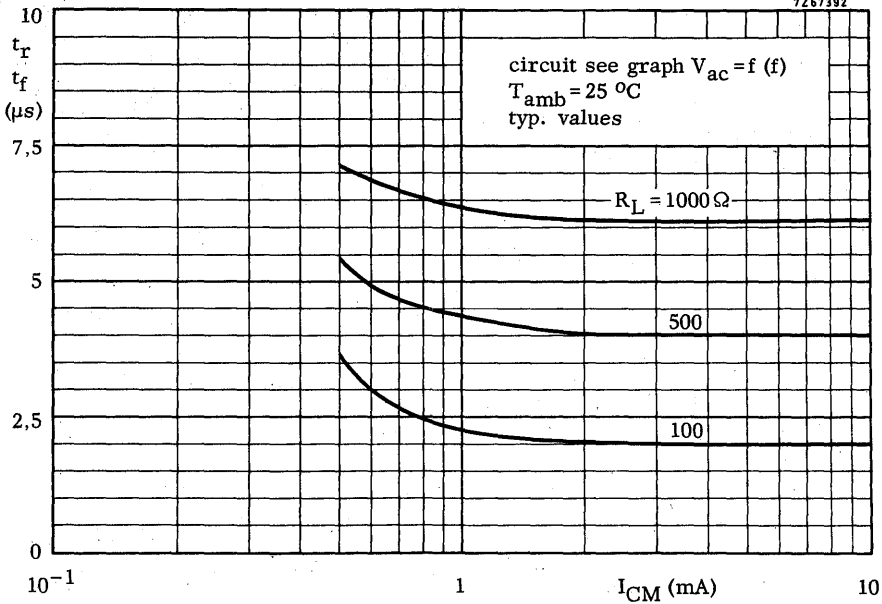

7267396

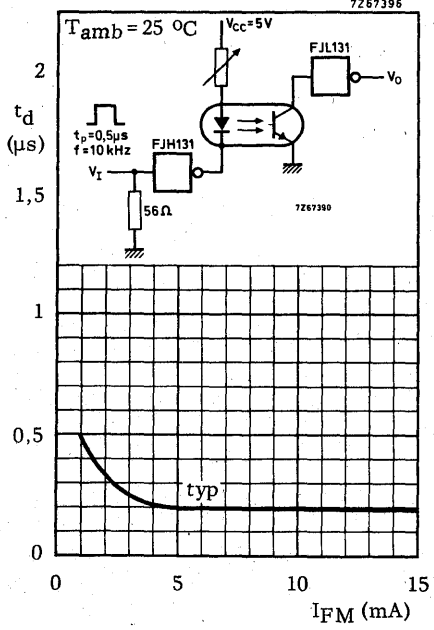

7267394

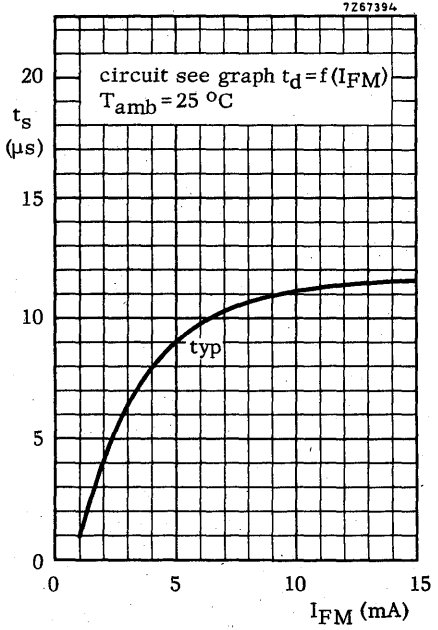

PHOTOCOUPLER

Optically coupled isolater consisting of an infrared emitting GaAs diode and a silicon n-p-n phototransistor. TO-12 envelope. Suitable for TTL integrated circuits. Only difference between CNY44 and CNY46 is in the pin connections.

QUICK REFERENCE DATA

Diode

Continuous reverse voltage	V_R	max.	3 V
Forward current (d. c.)	I_F	max.	30 mA
Forward current (peak value)	I_{FM}	max.	200 mA
Total power dissipation up to $T_{amb} = 100\text{ }^\circ\text{C}$	P_{tot}	max.	50 mW

Transistor

Collector-emitter voltage (open base)	V_{CE0}	max.	50 V
Collector cut-off current (dark) $V_{CE} = 15\text{ V}; I_F = 0$	I_{CE0}	<	100 nA
Total power dissipation up to $T_{amb} = 25\text{ }^\circ\text{C}$	P_{tot}	max.	80 mW

Photocoupler

Output/input d. c. current transfer ratio $I_F = 10\text{ mA}; V_{CE} = 10\text{ V}$	I_C/I_F	>	0,3
Collector-emitter saturation voltage $I_F = 10\text{ mA}; I_C = 3\text{ mA}$	V_{CEsat}	<	0,4 V
Isolation voltage, r. m. s. value	$V_{IO(RMS)}$	>	1000 V

MECHANICAL DATA

Dimensions in mm

TO-12

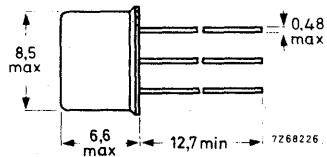
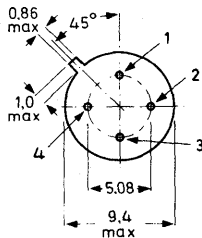
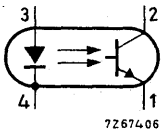

Cathode (4) connected to case.

Max. lead diameter is guaranteed only for 12,7 mm.

ALL OTHER DATA IDENTICAL TO CNY44

PHOTOCOUPLERS

Optically coupled isolators consisting of an infra-red emitting GaAs diode and a silicon n-p-n phototransistor. Plastic 6 lead dual in-line envelopes. Suitable for TTL integrated circuits.

QUICK REFERENCE DATA

Diode

Continuous reverse voltage	V_R	max.	3	V
Forward current (d. c.)	I_F	max.	30	mA
Total power dissipation up to $T_{amb} = 25\text{ }^\circ\text{C}$	P_{tot}	max.	100	mW

Transistor

Collector-emitter voltage (open base)	V_{CEO}	max.	30	V
Collector cut-off current (dark) $V_{CE} = 10\text{ V}; \text{ diode: } I_F = 0$	I_{CEO}	<	100	nA
Total power dissipation up to $T_{amb} = 25\text{ }^\circ\text{C}$	P_{tot}	max.	150	mW

Photocoupler

			CNY47	CNY47A
Output/input d. c. current transfer ratio $I_F = 10\text{ mA}; I_B = 0; V_{CE} = 0,4\text{ V}$	I_C/I_F	>	0,2	0,4
Collector-emitter saturation voltage $I_F = 10\text{ mA}; I_B = 0; I_C = 2\text{ mA}$	V_{CEsat}	<	0,4	V
$I_F = 10\text{ mA}; I_B = 0; I_C = 4\text{ mA}$	V_{CEsat}	<		0,4 V
Isolation voltage, r. m. s. value	$V_{IO(RMS)}$	>	2000	2000 V

MECHANICAL DATA See page 2.

CNY47
CNY47A

MECHANICAL DATA

Dimensions in mm

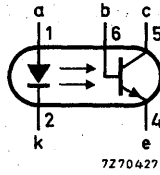

3 = n.c.

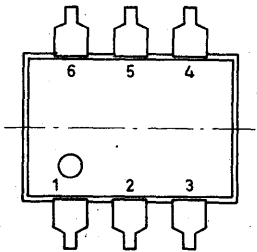
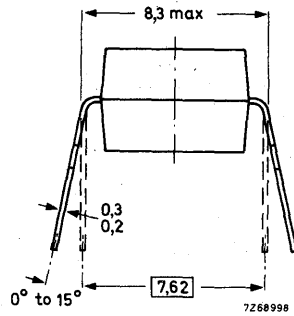
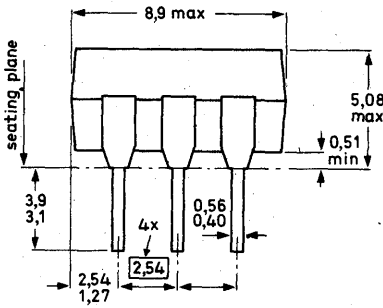

RATINGS Limiting values in accordance with the Absolute Maximum System (IEC 134)

Diode

Continuous reverse voltage	V_R	max.	3	V
Forward current (d. c.)	I_F	max.	30	mA
Forward current (peak value) $t_p < 10 \mu s; \delta < 0,1$	I_{FM}	max.	200	mA
Total power dissipation up to $T_{amb} = 25 \text{ }^\circ\text{C}$	P_{tot}	max.	100	mW
Operating junction temperature	T_j	max.	100	$^\circ\text{C}$

Transistor

Collector-emitter voltage (open base)	V_{CEO}	max.	30	V
Collector-base voltage (open emitter)	V_{CBO}	max.	50	V
Emitter-base voltage (open collector)	V_{EBO}	max.	4	V
Collector current (d. c.)	I_C	max.	30	mA
Total power dissipation up to $T_{amb} = 25 \text{ }^\circ\text{C}$	P_{tot}	max.	150	mW
Operating junction temperature	T_j	max.	100	$^\circ\text{C}$

Photocoupler

Storage temperature	T_{stg}	-55 to +150	$^\circ\text{C}$
---------------------	-----------	-------------	------------------

THERMAL RESISTANCE

From junction to ambient in free air				
- diode	$R_{th j-a}$	0,75	$^\circ\text{C}/\text{mW}$	
- transistor	$R_{th j-a}$	0,5	$^\circ\text{C}/\text{mW}$	
From junction to ambient, device mounted on a p. c. board ¹⁾				
- diode	$R_{th j-a}$	0,6	$^\circ\text{C}/\text{mW}$	
- transistor	$R_{th j-a}$	0,4	$^\circ\text{C}/\text{mW}$	

¹⁾ With copper islands of 1,5 mm diameter around each terminal, on one side of 1,6 mm glass-epoxy printed circuit board; thickness of copper 35 μm ; pins fully inserted (i. e. to seating plane, see drawing).

CNY47 CNY47A

CHARACTERISTICS

Diode $T_j = 25\text{ }^\circ\text{C}$

Forward voltage, $I_F = 10\text{ mA}$

V_F	typ.	1,2	V
	<	1,5	V

Reverse current, $V_R = 3\text{ V}$

I_R	<	100	μA
-------	---	-----	---------------

Transistor (diode: $I_F = 0$) $T_j = 25\text{ }^\circ\text{C}$

Collector cut-off current (dark)

$V_{CE} = 10\text{ V}$

I_{CEO}	typ.	5	nA
	<	100	nA

$V_{CB} = 10\text{ V}$

I_{CBO}	<	20	nA
-----------	---	----	----

Photocoupler ($I_B = 0$, $T_{amb} = 25\text{ }^\circ\text{C}$

unless otherwise specified) ¹⁾

		CNY47	CNY47A		
Output/input d. c. current transfer ratio	>	0,2	0,4		
$I_F = 10\text{ mA}$; $V_{CE} = 0,4\text{ V}$	I_C/I_F typ.	0,3	0,6)	
Collector-emitter saturation voltage					
$I_F = 10\text{ mA}$; $I_C = 2\text{ mA}$	V_{CEsat} typ.	0,2		V	
		<	0,4	V	
$I_F = 10\text{ mA}$; $I_C = 4\text{ mA}$	V_{CEsat} typ.		0,2	V	
			<	0,4	V
Isolation voltage, r. m. s. value	$V_{IO(RMS)}$ >	2000	2000	V ³⁾	
Capacitance between input and output					
$I_F = 0$; $V = 0$; $f = 1\text{ MHz}$	C_{i0} typ.	1	1	pF	

1) Where the phototransistor receives light from the diode, the O (for open terminal) has been omitted from the symbols.

2) Aging of the light-emitting diode reduces the transfer ratio at a rate proportional to current and operating time. In circuits that operate for long periods, therefore, the duty factor of the couplers should be kept as low as possible. This can often be done with the aid of an inverter.

3) Tested with a 50 Hz a. c. voltage for 1 minute between shorted input leads and shorted output leads.

CHARACTERISTICS (continued)

Insulation resistance between input and output

$V_{IO} = 500 \text{ V}$

		CNY47	CNY47A	
r_{IO}	>	10^{11}	10^{11}	Ω
	typ.	10^{12}	10^{12}	Ω

Switching times (circuit below)

$I_{Con} = 2 \text{ mA}; V_{CC} = 5 \text{ V}; R_L = 100 \Omega$

Turn-on time

t_{on}	typ.	3	μs
----------	------	---	---------------

Turn-off time

t_{off}	typ.	3	μs
-----------	------	---	---------------

$I_{Con} = 4 \text{ mA}; V_{CC} = 5 \text{ V}; R_L = 100 \Omega$

Turn-on time

t_{on}	typ.	5	μs
----------	------	---	---------------

Turn-off time

t_{off}	typ.	5	μs
-----------	------	---	---------------

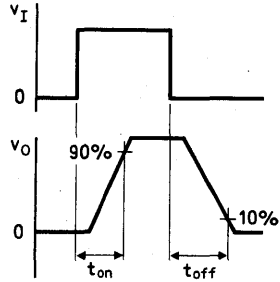
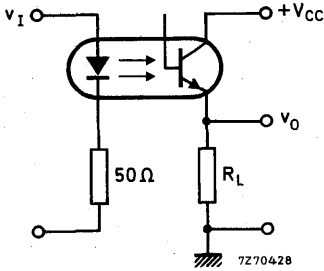

7267238.1



CNY47 CNY47A

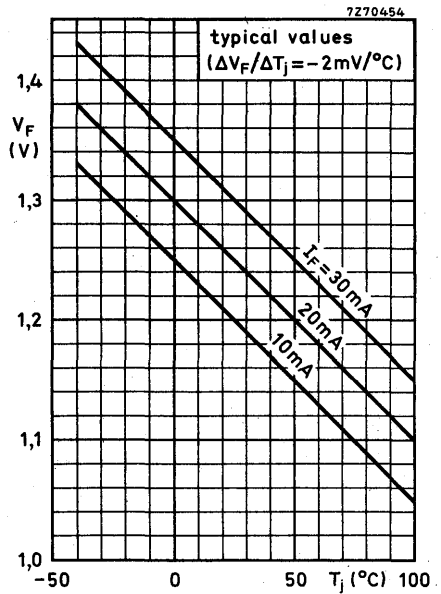
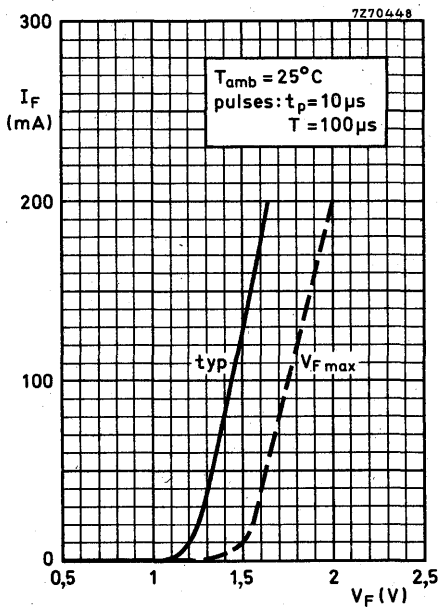
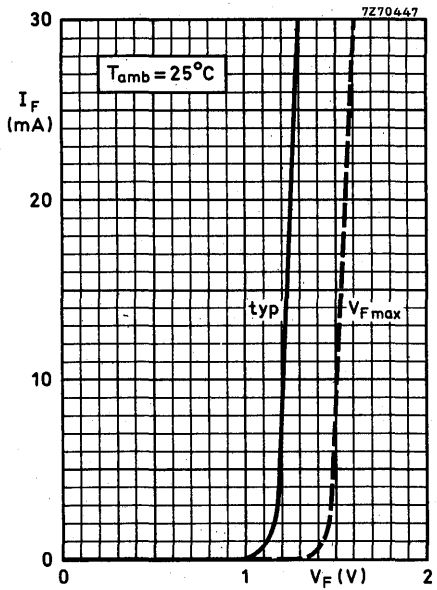
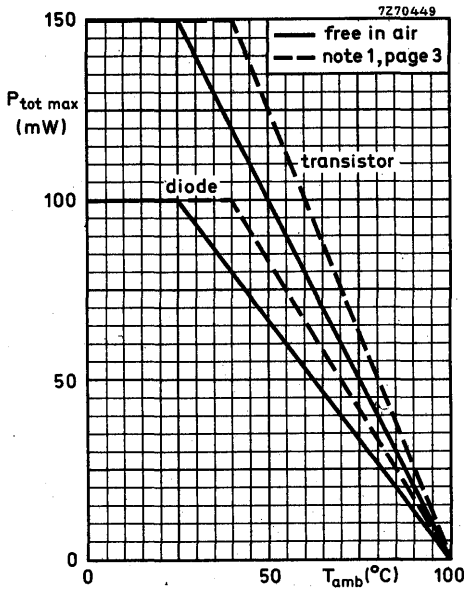

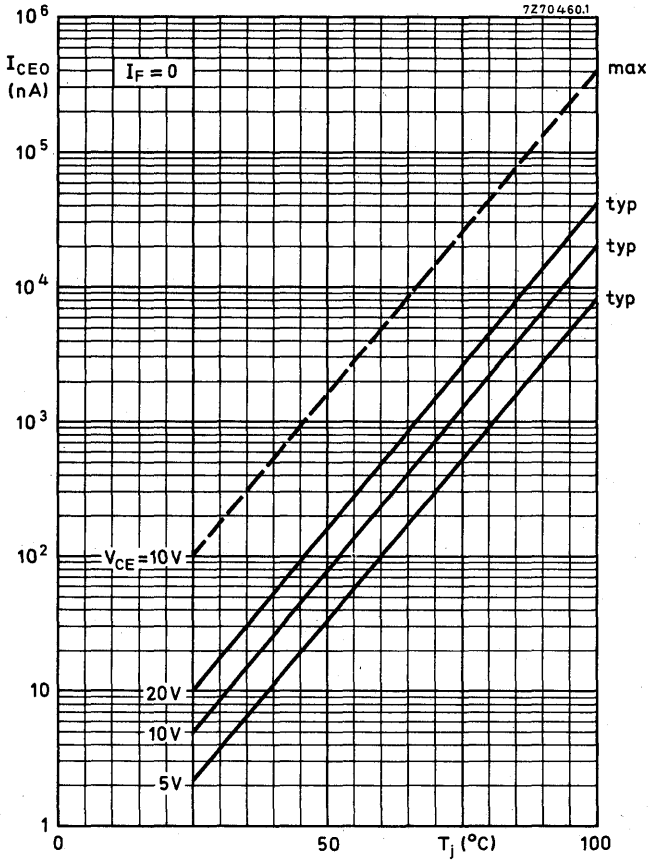

CNY47 CNY47A

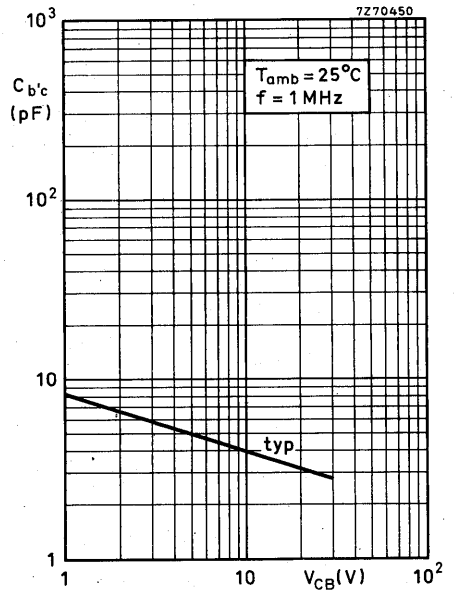
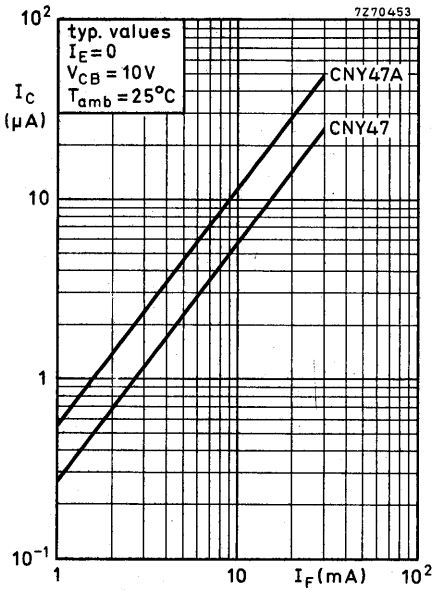
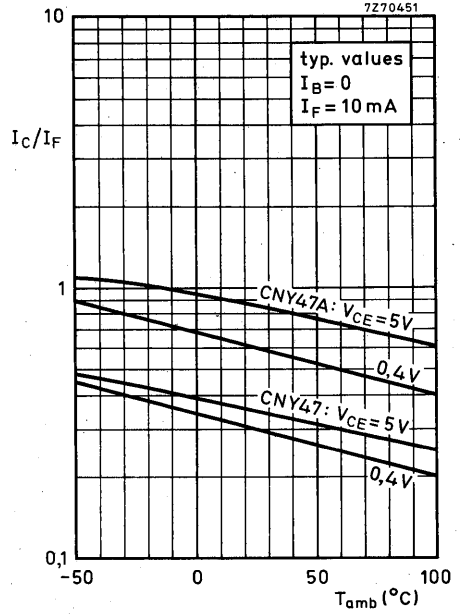
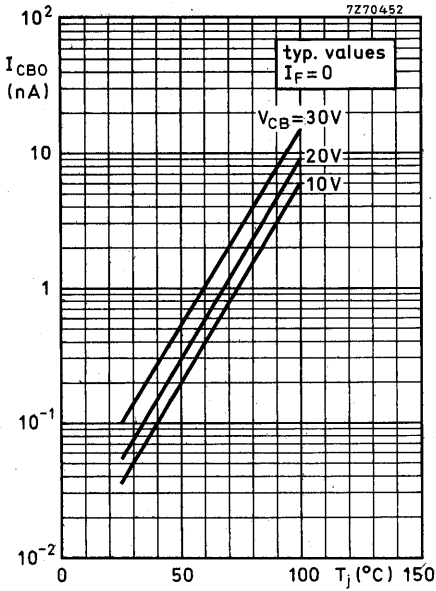

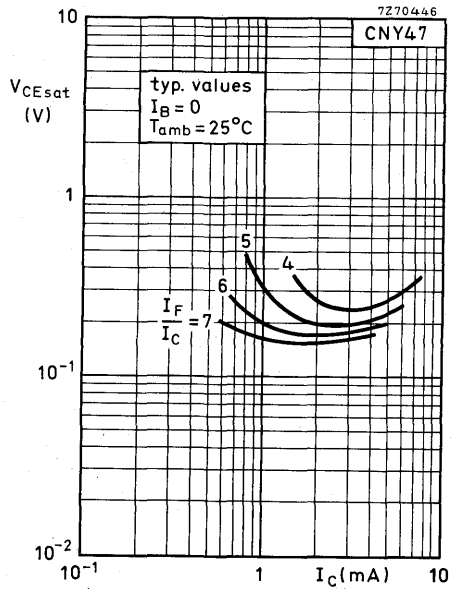
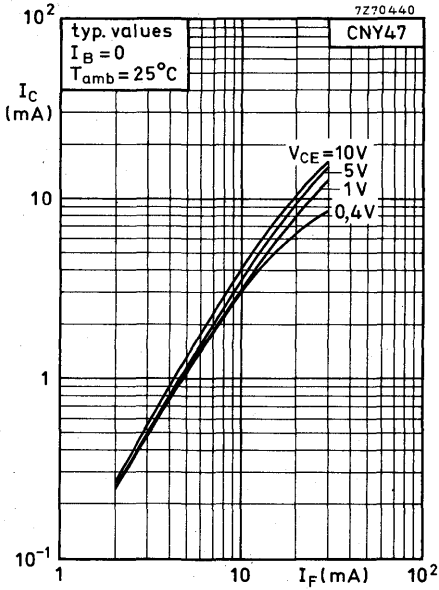
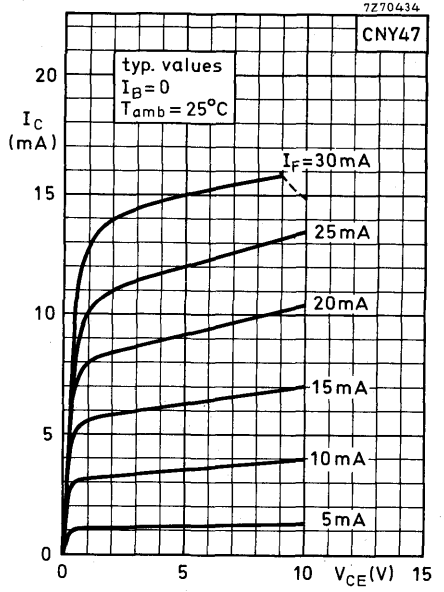
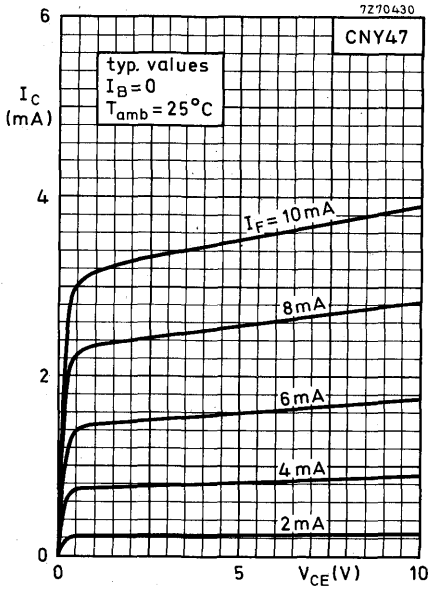

**CNY47
CNY47A**

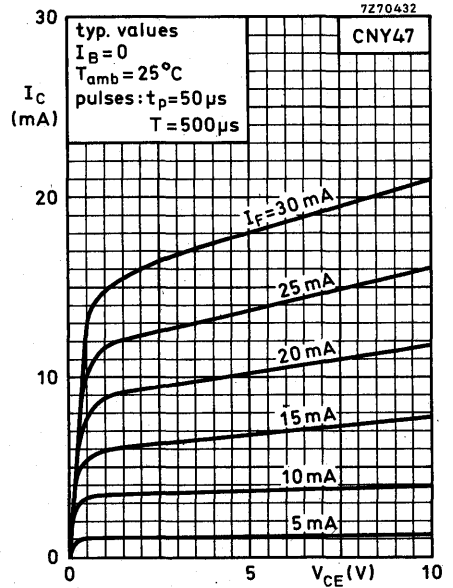
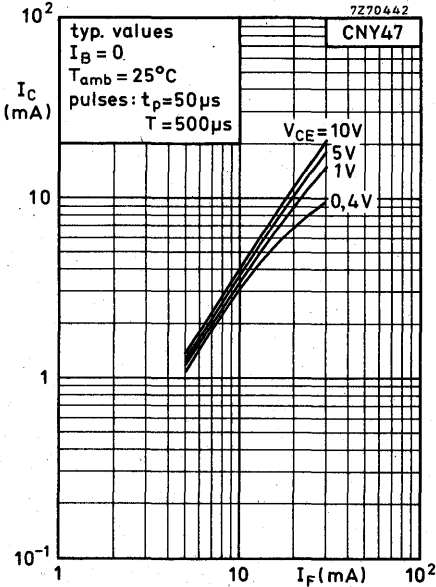
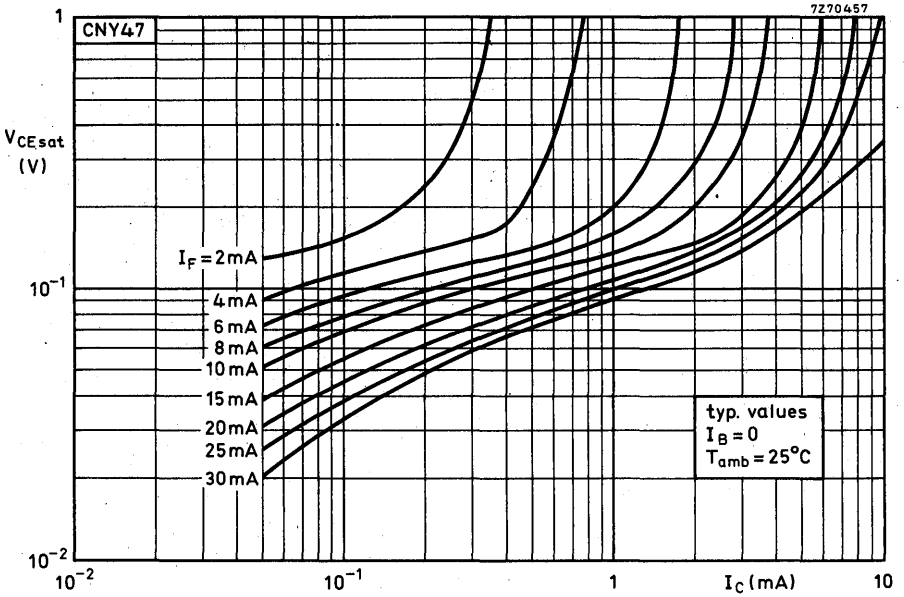

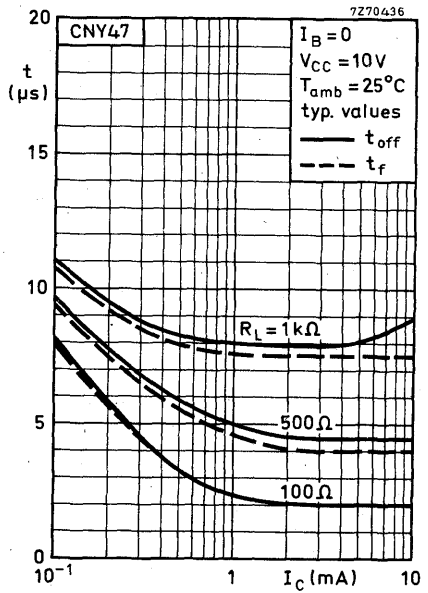
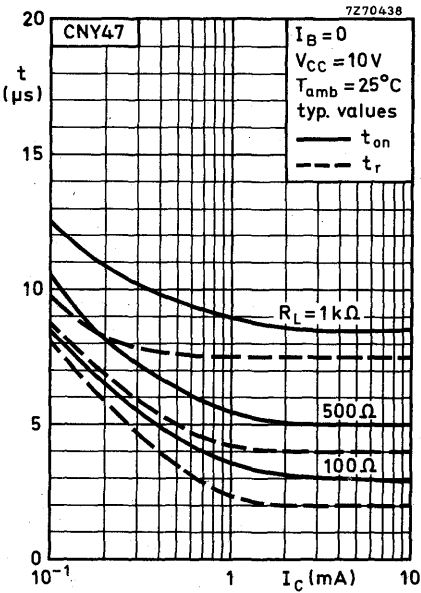
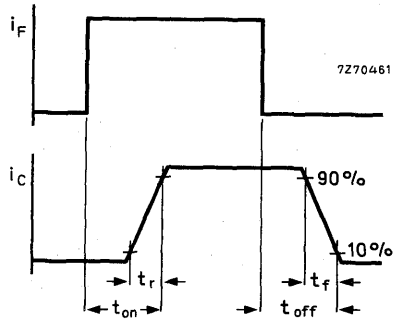
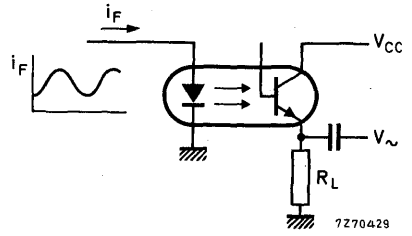
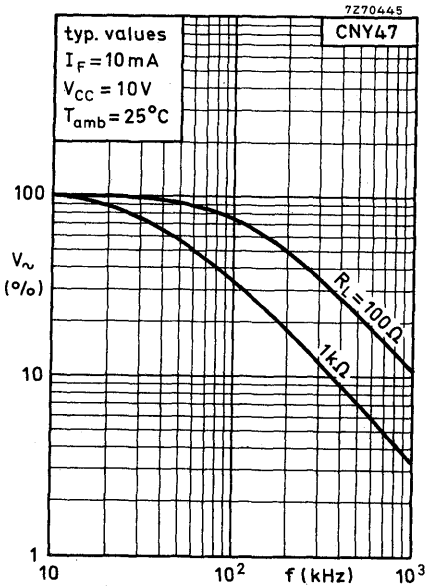

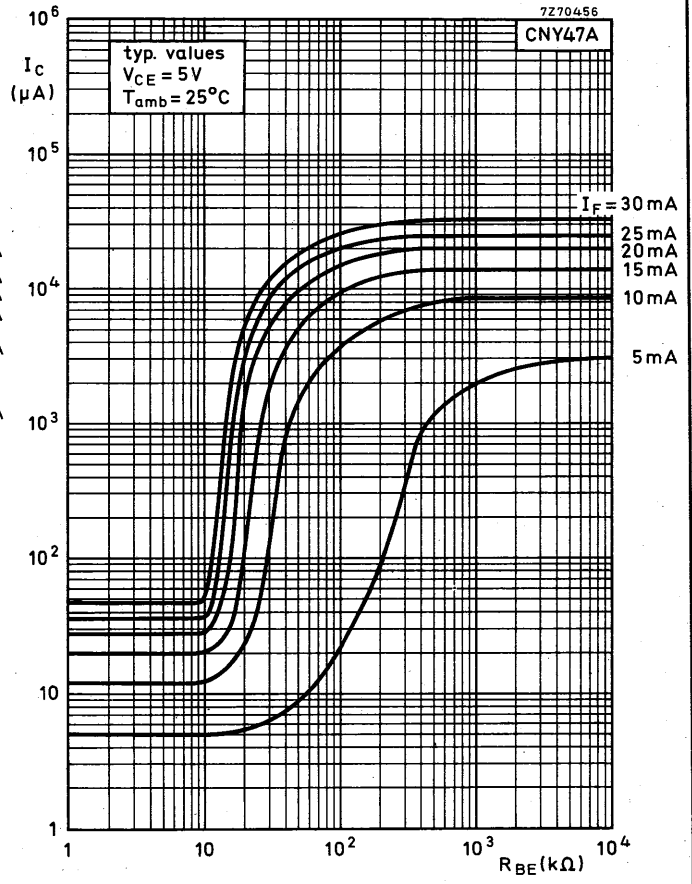
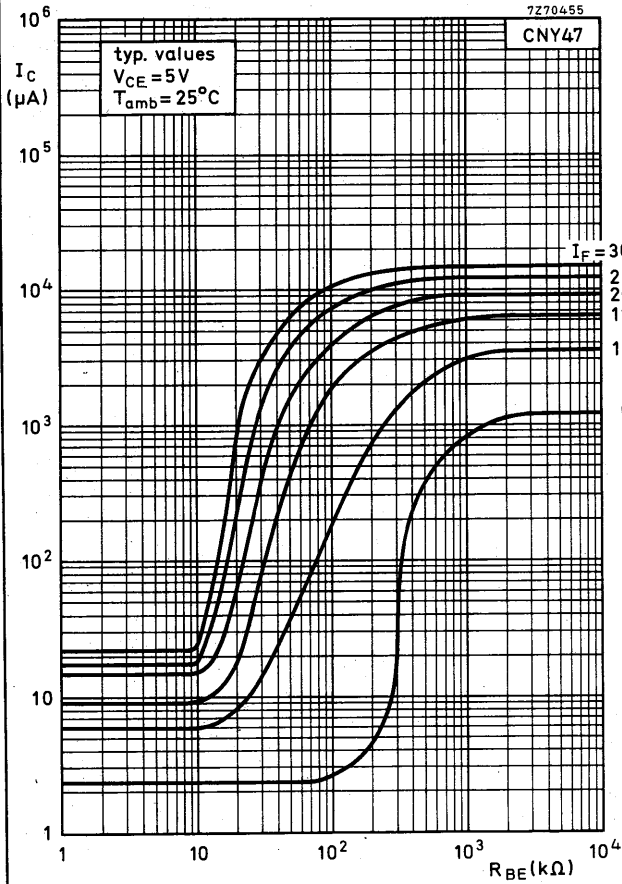

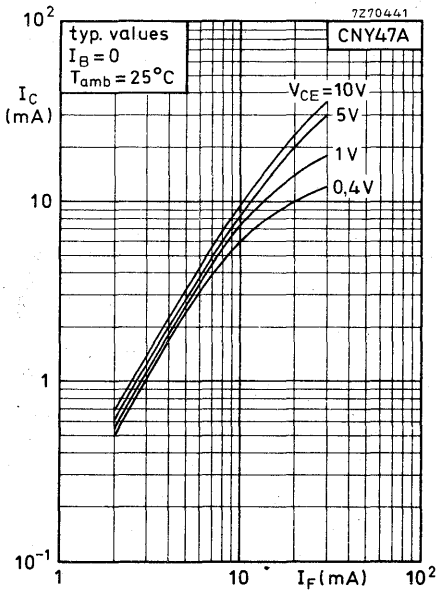
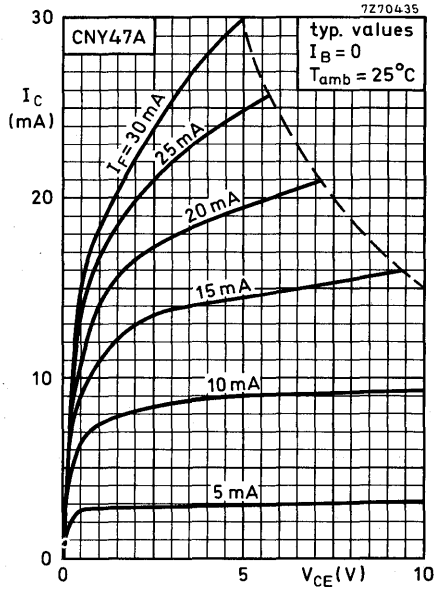
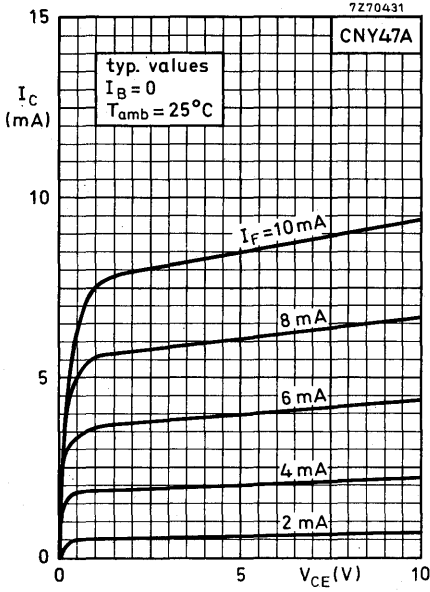

**CNY47
CNY47A**

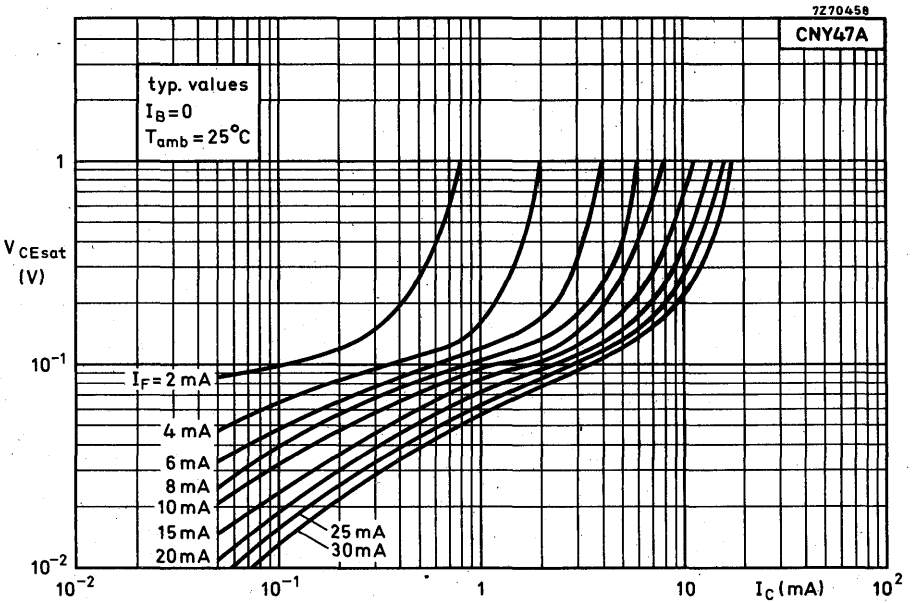
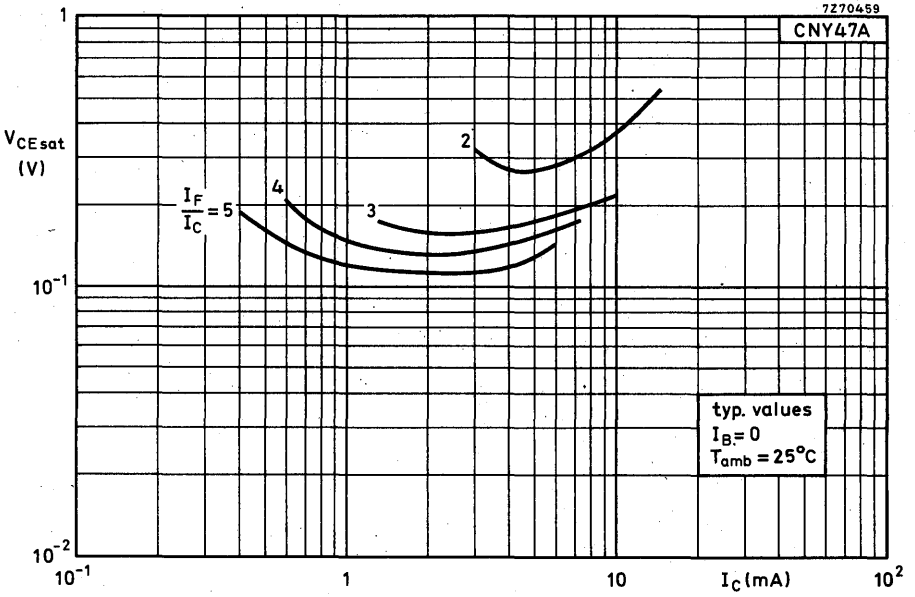

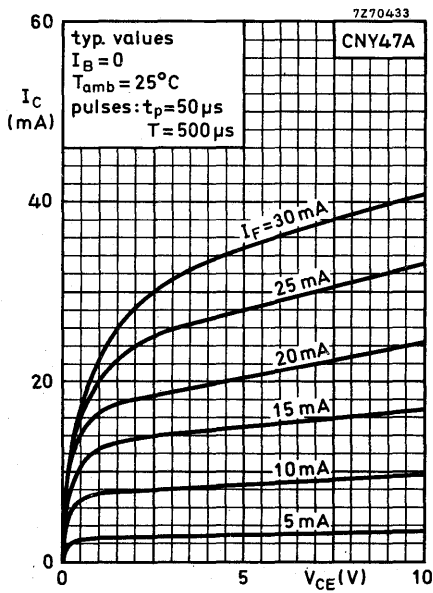
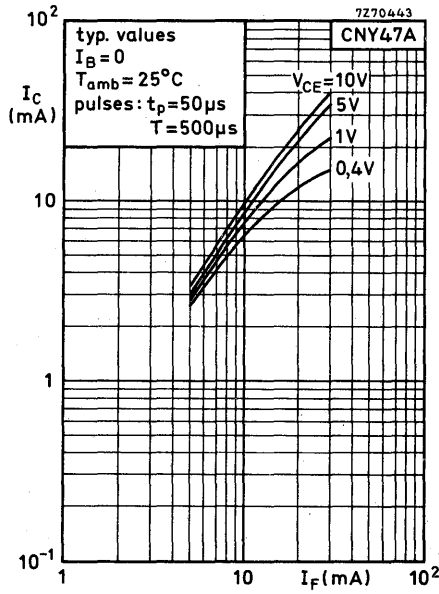

CNY47 CNY47A

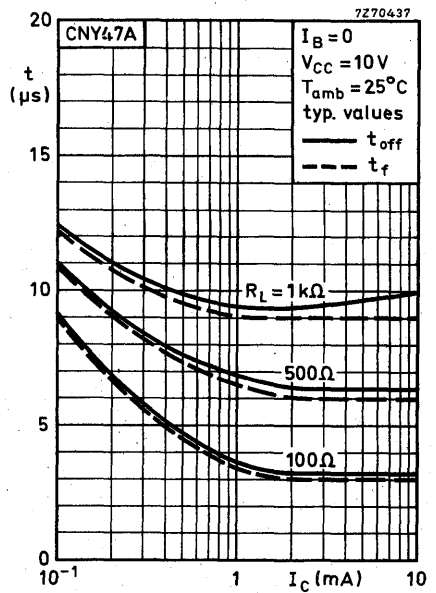
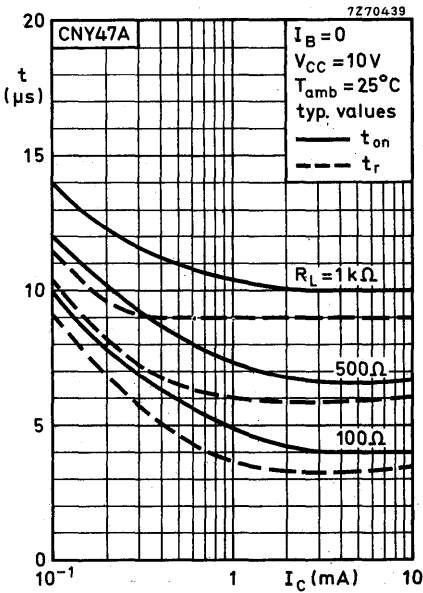
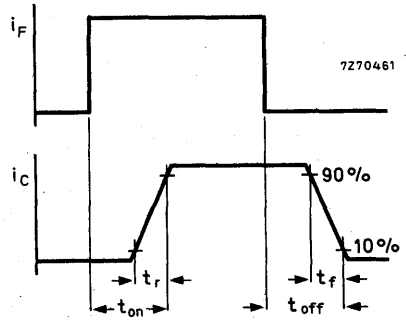
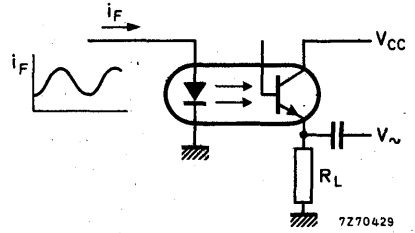
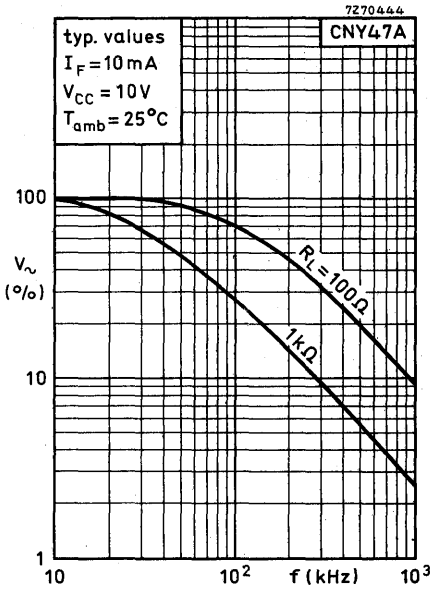

PHOTOCOUPLER

Optically coupled isolator consisting of an infrared emitting GaAs diode and a silicon n-p-n Darlington phototransistor. Plastic 6 lead dual-in line envelope. Suitable for TTL integrated circuits.

QUICK REFERENCE DATA

Diode

Continuous reverse voltage	V_R	max.	3 V
Forward current (d. c.)	I_F	max.	60 mA
Total power dissipation up to $T_{amb} = 25\text{ }^\circ\text{C}$	P_{tot}	max.	100 mW

Transistor

Collector-emitter voltage (open base)	V_{CEO}	max.	30 V
Collector cut-off current (dark) $V_{CE} = 10\text{ V}$; diode: $I_F = 0$	I_{CEO}	<	100 nA
Total power dissipation up to $T_{amb} = 25\text{ }^\circ\text{C}$	P_{tot}	max.	150 mW

Photocoupler

Output/input d. c. current transfer ratio $I_F = 10\text{ mA}$; $I_B = 0$; $V_{CE} = 1\text{ V}$	I_C/I_F	>	6
Collector-emitter saturation voltage $I_F = 5\text{ mA}$; $I_B = 0$; $I_C = 10\text{ mA}$	V_{CEsat}	<	0,8 V
$I_F = 10\text{ mA}$; $I_B = 0$; $I_C = 60\text{ mA}$	V_{CEsat}	<	1,0 V
Isolation voltage, r. m. s. value	$V_{IO(RMS)}$	>	1500 V

MECHANICAL DATA See page 2.

MECHANICAL DATA

Dimensions in mm

SOT-90

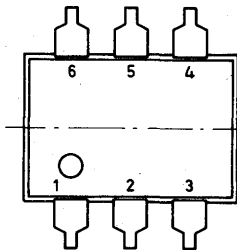
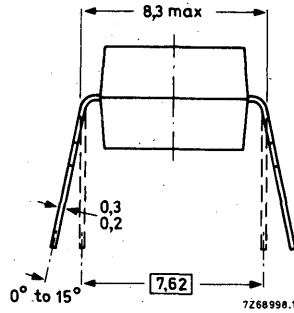
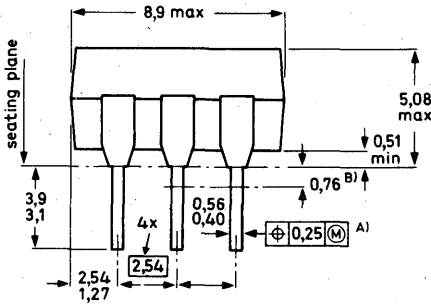
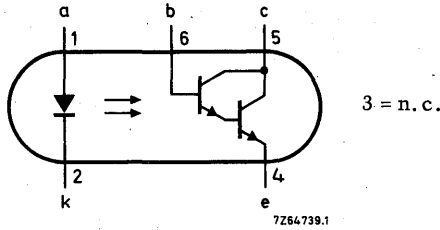

A) Centre lines of all leads are within $\pm 0,127$ mm of the nominal positions shown: in the worst case, the spacing between adjacent leads may deviate from nominal by $\pm 0,254$ mm.

B) Tolerances of note A within this distance.

⊕ Locational truth

Ⓜ Maximum Material Condition

RATINGS Limiting values in accordance with the Absolute Maximum System (IEC 134)Diode

Continuous reverse voltage	V_R	max.	3 V
Forward current (d. c.)	I_F	max.	60 mA
Forward current (peak value) $t_p < 10 \mu\text{s}; f = 300 \text{ Hz}$	I_{FM}	max.	3 A
Total power dissipation up to $T_{amb} = 25 \text{ }^\circ\text{C}$	P_{tot}	max.	100 mW
Junction temperature	T_j	max.	100 $^\circ\text{C}$

Transistor

Collector-emitter voltage (open base)	V_{CEO}	max.	30 V
Collector-base voltage (open emitter)	V_{CBO}	max.	30 V
Emitter-base voltage (open collector)	V_{EBO}	max.	6 V
Collector current (d. c.)	I_C	max.	100 mA
Collector current (peak value) $t_p < 100 \mu\text{s}; T = 1 \text{ ms}$	I_{CM}	max.	150 mA
Total power dissipation up to $T_{amb} = 25 \text{ }^\circ\text{C}$	P_{tot}	max.	150 mW
Junction temperature	T_j	max.	100 $^\circ\text{C}$

Photocoupler

Storage temperature	T_{stg}	-55 to +100	$^\circ\text{C}$
---------------------	-----------	-------------	------------------

THERMAL RESISTANCE

From junction to ambient in free air

- diode	$R_{th j-a}$	0,75	$^\circ\text{C}/\text{mW}$
- transistor	$R_{th j-a}$	0,5	$^\circ\text{C}/\text{mW}$

From junction to ambient

device mounted on a p. c. board

- diode	$R_{th j-a}$	0,6	$^\circ\text{C}/\text{mW}$
- transistor	$R_{th j-a}$	0,4	$^\circ\text{C}/\text{mW}$

CHARACTERISTICS

Diode $T_j = 25\text{ }^\circ\text{C}$

Forward voltage, $I_F = 10\text{ mA}$

V_F	typ.	1,2 V
	<	1,5 V

Reverse current, $V_R = 3\text{ V}$

I_R	<	10 μA
-------	---	------------------

Diode capacitance, $V_R = 0$; $f = 1\text{ MHz}$

C_d	typ.	80 pF
-------	------	-------

Transistor (diode: $I_F = 0$) $T_j = 25\text{ }^\circ\text{C}$

Collector cut-off current (dark)

$V_{CE} = 10\text{ V}$

I_{CEO}	<	100 nA
-----------	---	--------

Photocoupler ($I_B = 0$, $T_{amb} = 25\text{ }^\circ\text{C}$

unless otherwise specified) ¹⁾

Output/input d. c. current transfer ratio

$I_F = 10\text{ mA}$; $V_{CE} = 1\text{ V}$

I_C/I_F	>	6	²⁾
-----------	---	---	---------------

Collector-emitter saturation voltage

$I_F = 5\text{ mA}$; $I_C = 10\text{ mA}$

V_{CEsat}	<	0,8 V
-------------	---	-------

$I_F = 10\text{ mA}$; $I_C = 60\text{ mA}$

V_{CEsat}	<	1 V
-------------	---	-----

Isolation voltage, r. m. s. value

$V_{IO(RMS)}$	>	1500 V	³⁾
---------------	---	--------	---------------

Capacitance between input and output

$I_F = 0$; $V = 0$; $f = 1\text{ MHz}$

C_{io}	typ.	1 pF
----------	------	------

¹⁾ Where the phototransistor receives light from the diode, the O (for open terminal) has been omitted from the symbols.

²⁾ Aging of the light-emitting diode reduces the transfer ratio at a rate proportional to current and operating time. In circuits that operate for long periods, therefore, the duty factor of the couplers should be kept as low as possible. This can often be done with the aid of an inverter.

³⁾ Tested with a 50 Hz a. c. voltage for 1 minute between shorted input leads and shorted output leads.

CHARACTERISTICS (continued)

$T_{amb} = 25\text{ }^{\circ}\text{C}$, unless otherwise specified

Insulation resistance between input and output

$V_{IO} = 1500\text{ V}$

r_{IO} typ. $10^{11}\ \Omega$

Switching times (circuit below)

$I_{Con} = 10\text{ mA}$; $V_{CC} = 10\text{ V}$; $R_E = 100\ \Omega$

Turn-on time

t_{on} typ. $68\ \mu\text{s}$

Turn-off time

t_{off} typ. $37\ \mu\text{s}$

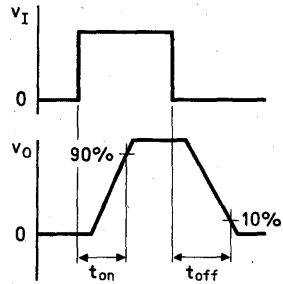
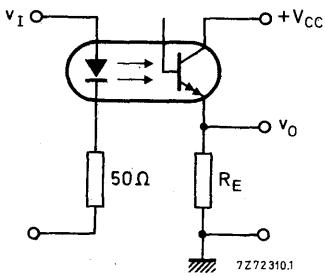

7267238.1

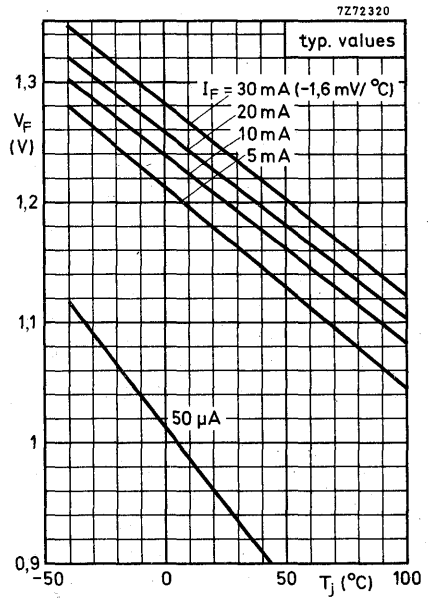
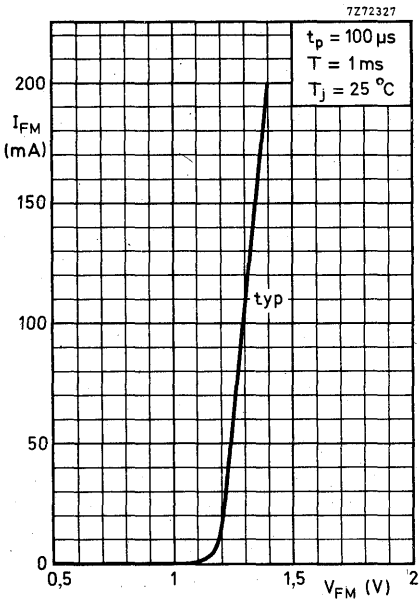
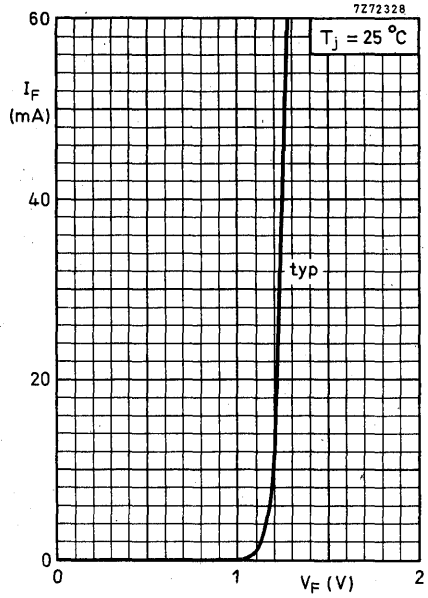
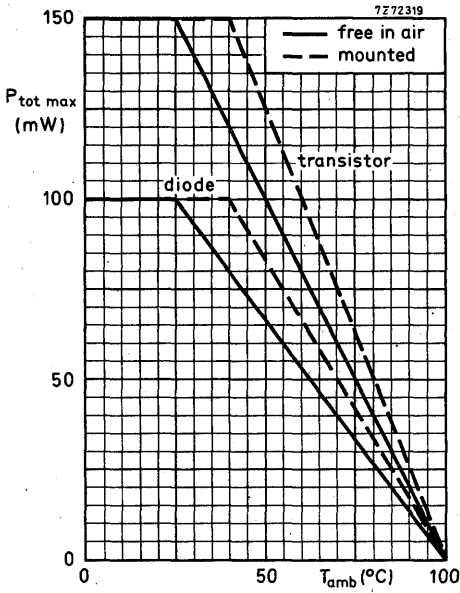

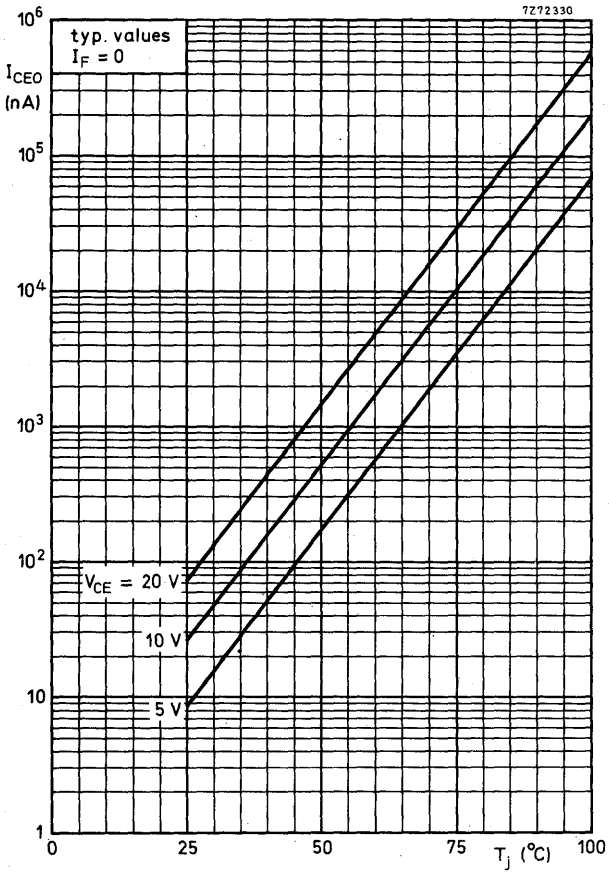

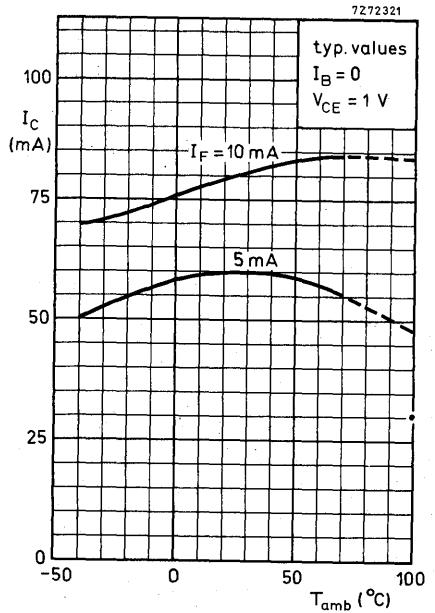
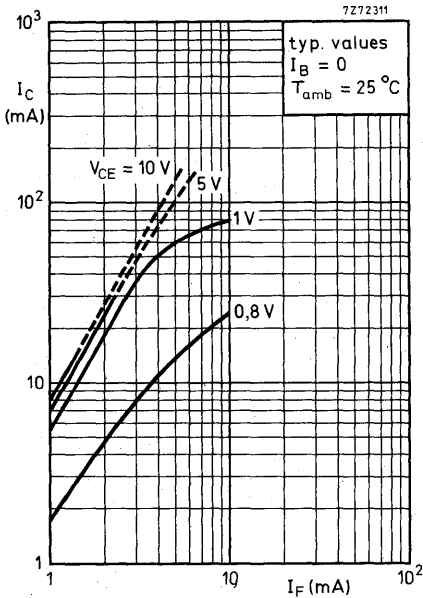
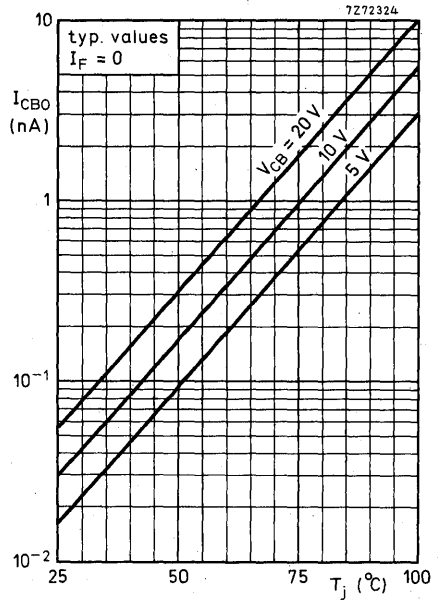
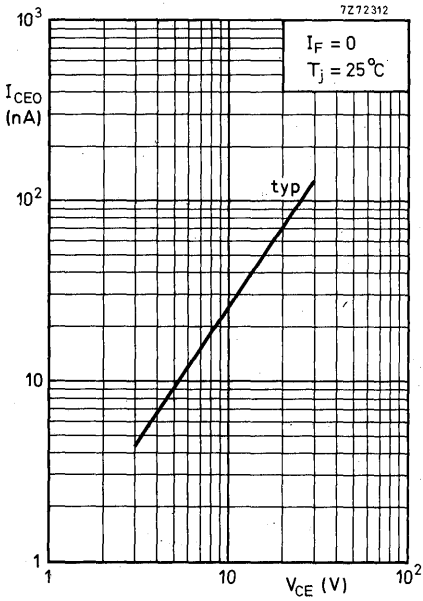

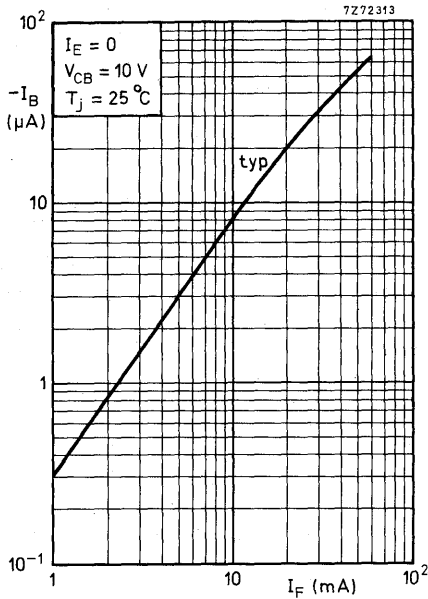
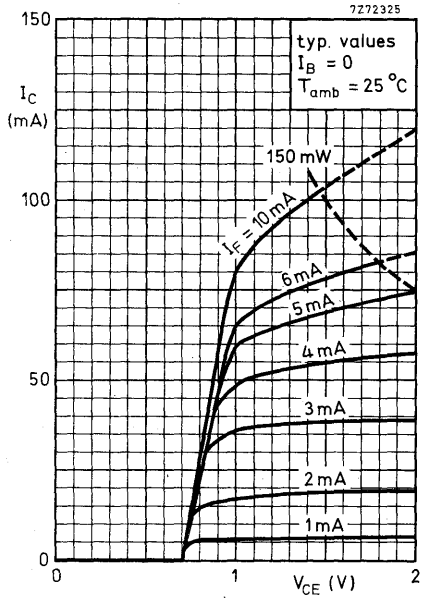
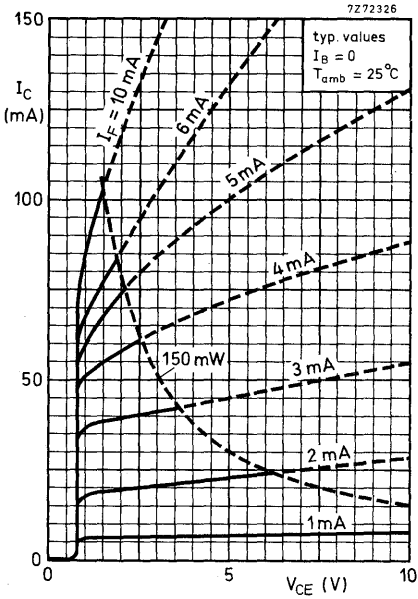

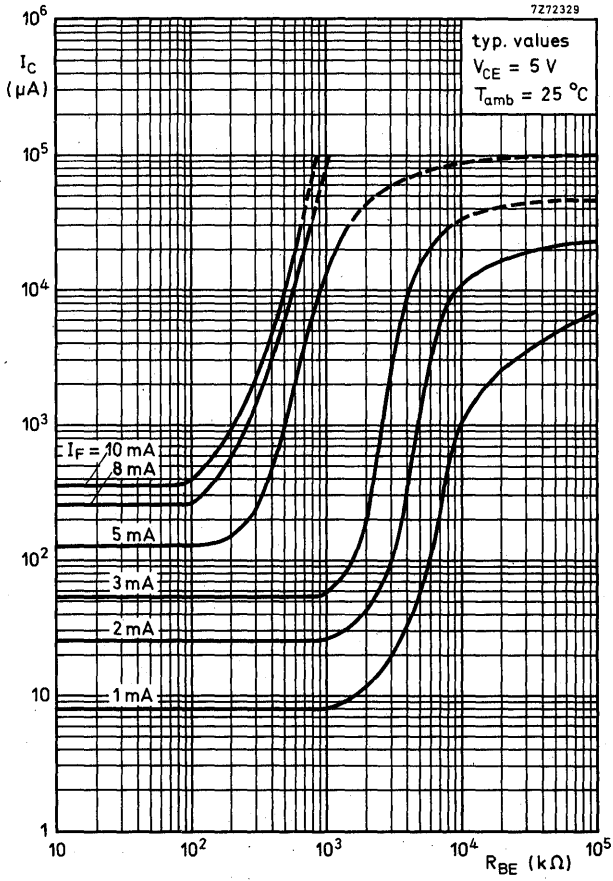

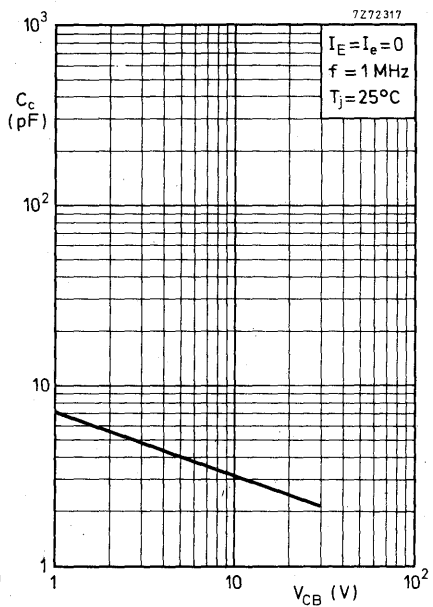
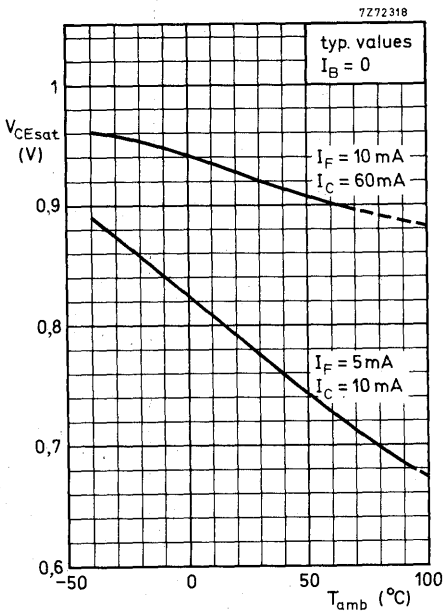
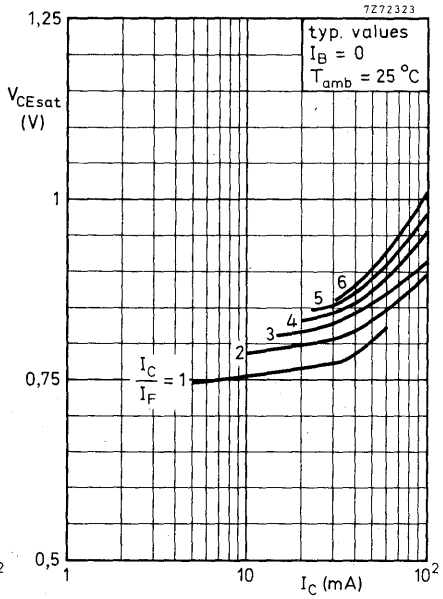
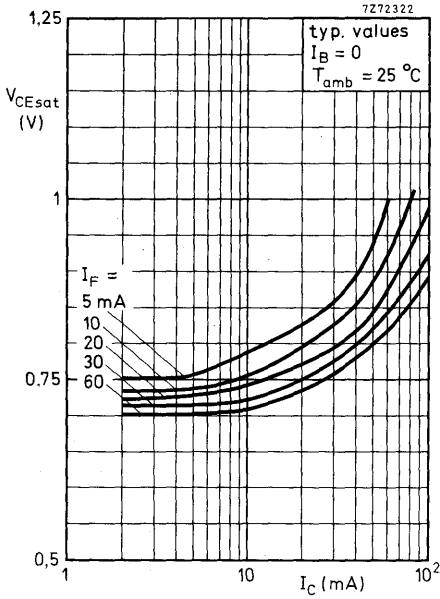

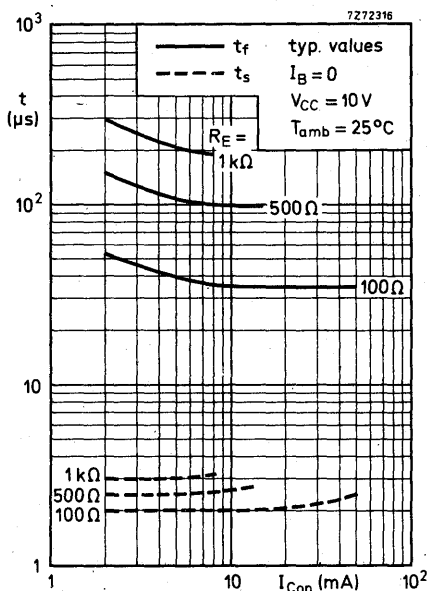
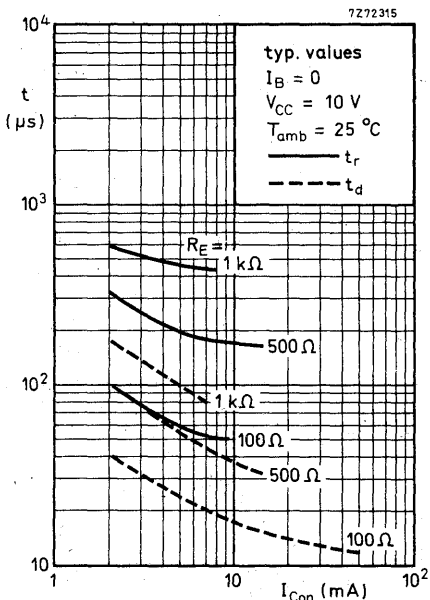
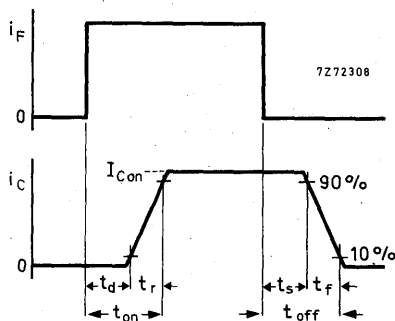
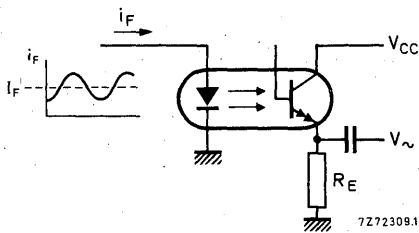
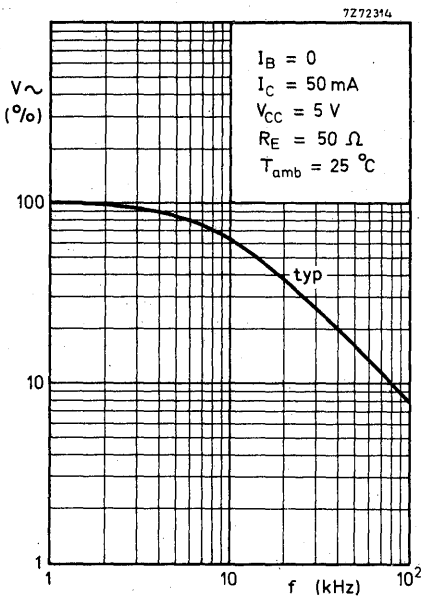

INFRARED SENSITIVE DEVICES



MECHANICAL DATA

Dimensions in mm

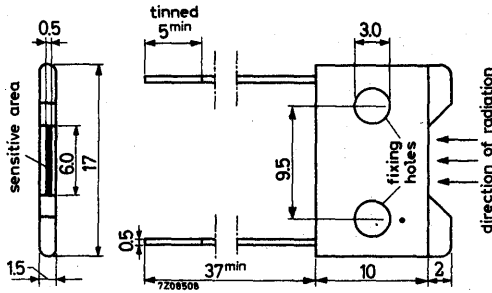

NOTES

1. Measuring conditions.

The detector is attached to a heatsink which is maintained at a temperature of 20 °C and a bias current of 50 mA is applied. A parallel beam of monochromatic radiation of wavelength 4.4 μm, which would produce a steady irradiance of 68 μW/cm² at the sensitive element, is chopped at 800 Hz, giving an actual r.m.s. power at the element which amounts to

$$\frac{68}{2.2} = 31 \mu\text{W}/\text{cm}^2$$

Measurements of the detector output are made with an amplifier tuned to 800 Hz and with a bandwidth of 50 Hz, and are referred to open circuit conditions i.e. correction is made for the shunting effects of the bias supply impedance and the amplifier input impedance. Under these test conditions, the ORP10 will exhibit a minimum signal-to-noise ratio of 45 and typical of 105. The sensitivities quoted at the wavelength of peak response and under black body conditions are calculated from these measurements, assuming the detector to have a typical response curve.

2. D* and N.E.P.

These are figures of merit for the materials of detectors.

D* is defined in the expression:

$$D^* = \frac{\frac{V_s}{V_n} \times \sqrt{A(\Delta f)}}{W}$$

- where: V_s = signal voltage across detector terminals
 V_n = noise voltage across detector terminals
 A = detector area
 (Δf) = bandwidth of measuring amplifier
 W = radiation power incident on detector sensitive element in watts.

NOTES (continued)

The figures in brackets which follow D^* refer to the measuring conditions e.g. D^* (5.3 μm , 800 Hz, 1 Hz) denotes monochromatic radiation incident on the detector of wavelength 5.3 μm , chopping frequency 800 Hz, bandwidth 1 Hz.

The Noise Equivalent Power (N.E.P.) is related to D^* by the expression:

$$\text{N.E.P.} = \frac{\sqrt{A}}{D^*}$$

3. Variation of performance with bias current.

Both signal and noise vary with bias current. Typical curves are shown on page 5. At high currents the noise increases more rapidly than the signal, and therefore the signal-to-noise ratio has a peak value at some optimum current, which will vary slightly from cell to cell. A typical value is 50 mA. In addition the ohmic heating caused by bias currents above 60 mA causes the temperature of the element to become significantly greater than the substrate so that the signal decreases as described in note 4.

4. Variation of performance with element temperature.

As with all semiconductor photocells, the performance depends on the temperature of the sensitive element. In the case of the ORP10 this is influenced by the ambient temperature and ohmic heating caused by the d.c. bias current. To minimise fluctuations, the element is mounted on a copper base from which it is insulated by a layer of aluminium oxide, and can readily be attached to a large heatsink.

A typical variation of performance with temperature is given on page 5. The curve on page 5 shows the decrease in signal caused by the high current raising the temperature of the element.

On cooling, indium antimonide exhibits improved sensitivity and increased resistance. Below 15 °C this is impractical with the ORP10 unless special precautions are taken to prevent condensation and icing on the exposed element.

5. Warning.

The sensitive surface is unprotected and should not be touched. It is stable in normal atmospheres but should not be exposed to high concentrations of the vapours of organic solvents. Care should be taken to avoid strain when attaching cells to heatsinks.

ORP10

Recommended circuit for use with radiation chopped at 800 Hz.

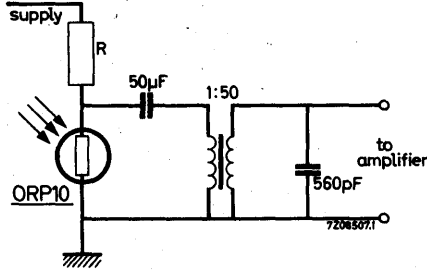

CIRCUIT NOTES

The transformer should be adequately screened to prevent stray pick-up. The resistor R should be wire wound to minimise noise. It must be substantially larger than the cell resistance and its actual value will depend upon the supply voltage and the cell currents required. The 560 pF capacitor tunes the secondary to 800 Hz.

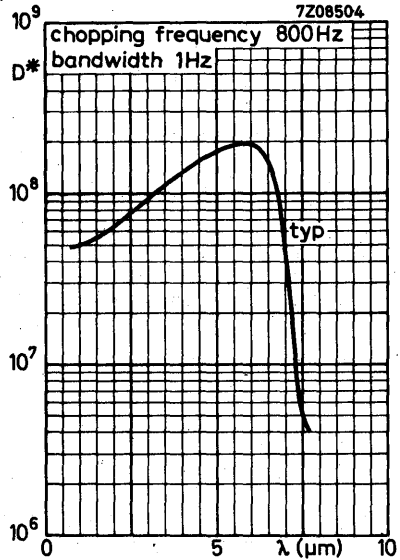
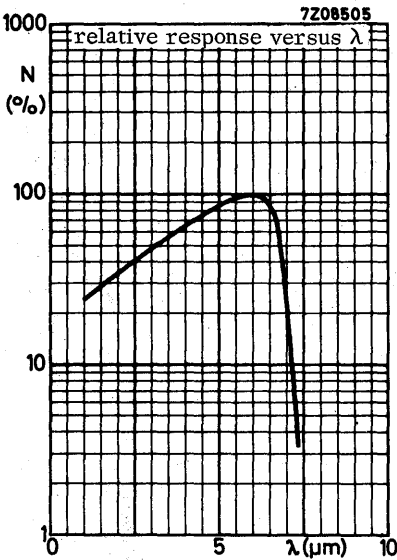

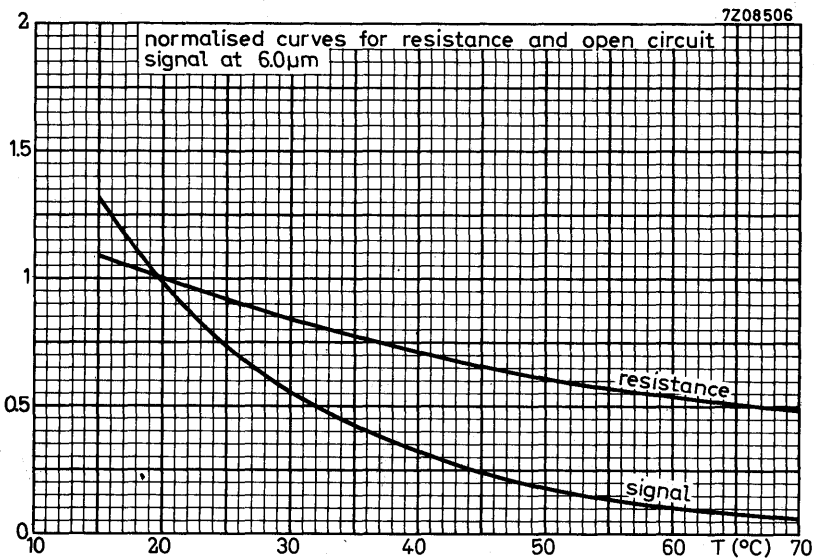
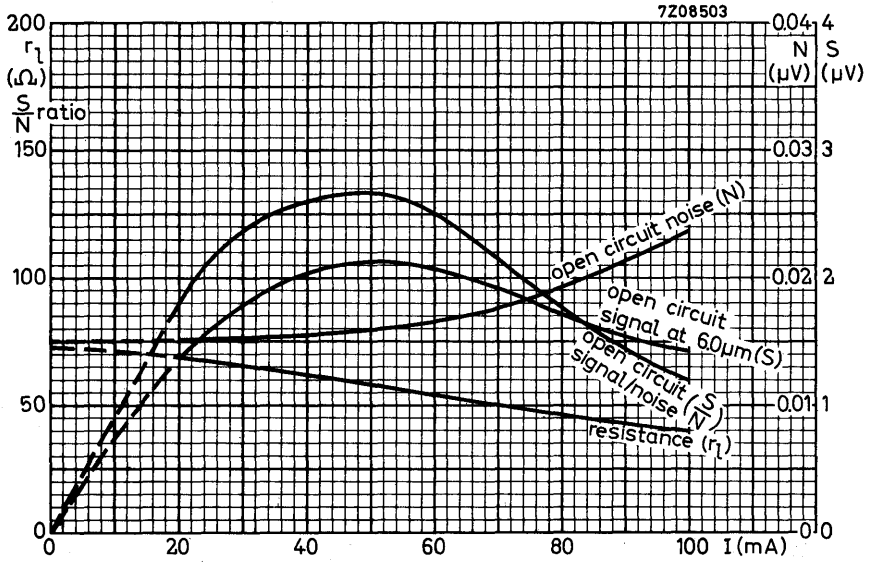

PHOTOCONDUCTIVE CELL

Indium antimonide photoconductive element mounted in a glass dewar vessel and cooled by liquid nitrogen or liquid air. Sensitive to infrared radiation extending to 5.6 μm and intended for use with modulated or pulsed radiation.

QUICK REFERENCE DATA

Peak spectral response	λ_m	5.3 μm
Operating temperature	T	77 K
Responsivity (5.3 μm , 800 Hz)	typ.	35 mV/ μW
D^* (5.3 μm , 800 Hz, 1 Hz)	typ.	5.5×10^{10} cm $\sqrt{\text{Hz}/\text{W}}$
Time constant	typ.	5 μs
Sensitive area		6.0 x 0.5 mm ²

MECHANICAL DATA see page 2



MECHANICAL DATA

Dimensions in mm

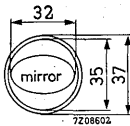
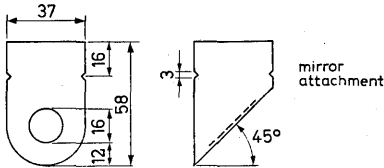
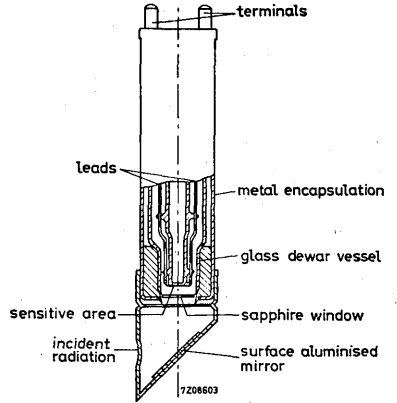
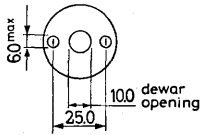
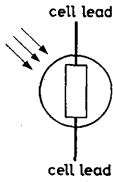
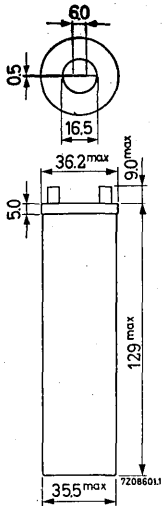

NOTES

1. Test conditions

The detector is cooled to 77K by filling the dewar vessel with liquid nitrogen, or by use of a liquid transfer system. An optimum bias of 250 to 500μA is applied. The sensitive element is situated at a distance of 264mm from a black body source limited by an aperture of 3mm diameter.

The radiation path is interrupted at 800Hz by a chopper blade at ambient temperature. Under these conditions the r. m. s. power at the element (chopping factor 2.2) is 4.5μW/cm².

Measurements of the detector output are made with an amplifier tuned to 800Hz with a bandwidth of 50Hz, and referred to open-circuit conditions, i. e. , correction is made for the shunting effects of the bias supply impedance and the amplifier impedance.

2. D* and N. E. P.

These are figures of merit for the materials of detectors.

The detectivity D* is defined in the expression:

$$D^* = \frac{\frac{V_s}{V_n} \sqrt{A(\Delta f)}}{W}$$

where: V_s = signal voltage across detector terminals

V_n = noise voltage across detector terminals

A = detector area

(Δf) = bandwidth of measuring amplifier

W = radiation power incident on detector sensitive element in r. m. s. watts.

The Noise Equivalent Power (N. E. P.) is related to D* by the expression:

$$N. E. P. = \frac{\sqrt{A}}{D^*}$$

3. Time constant

Detector time constant figures are based on the response to a step function in the incident radiation. Quoted times indicate the interval between the moment the radiation is cut off and the output falling to 63% of its peak value.

4. Variation of performance with bias current

Both signal and noise vary with current in this type of cell. At high currents the noise increases more rapidly than the signal, and therefore the signal-to-noise ratio has a peak value at some optimum current, which will vary slightly from cell to cell.

NOTES (continued)

5. Warnings

a. The resistance of the cell at room temperature is three orders of magnitude less than at the operating temperature (77K). Care should therefore be taken to ensure that the device is not allowed to reach room temperature while still biased, if any form of low impedance biasing is employed.

b. If provision is made for cells to be plugged into the bias current and amplifier, steps must be taken to limit the current available from the amplifier input capacitor. This current can be excessive at the instant of plugging in the cell.

A zener diode can be used to limit the voltage developed across the input capacitor as shown in the diagram.

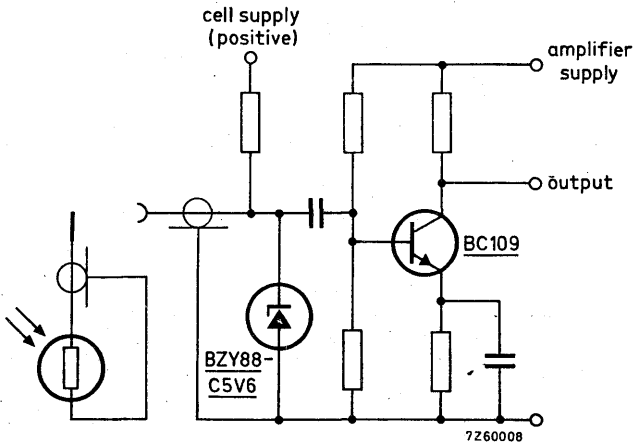

c. The dewar vessel must always be completely dry before being refilled with liquid nitrogen. In humid conditions, water vapour may condense at the top of the dewar. Should this occur, the remaining liquid nitrogen should be allowed to boil off, the ice should be removed carefully and precautions taken to avoid a recurrence. In very humid conditions the window should be purged with a clean dry gas.

6. Low frequency noise

This will be minimised by use of non-absorbent cotton wool placed in the bottom of the dewar. The recommended quantity is 40mg.

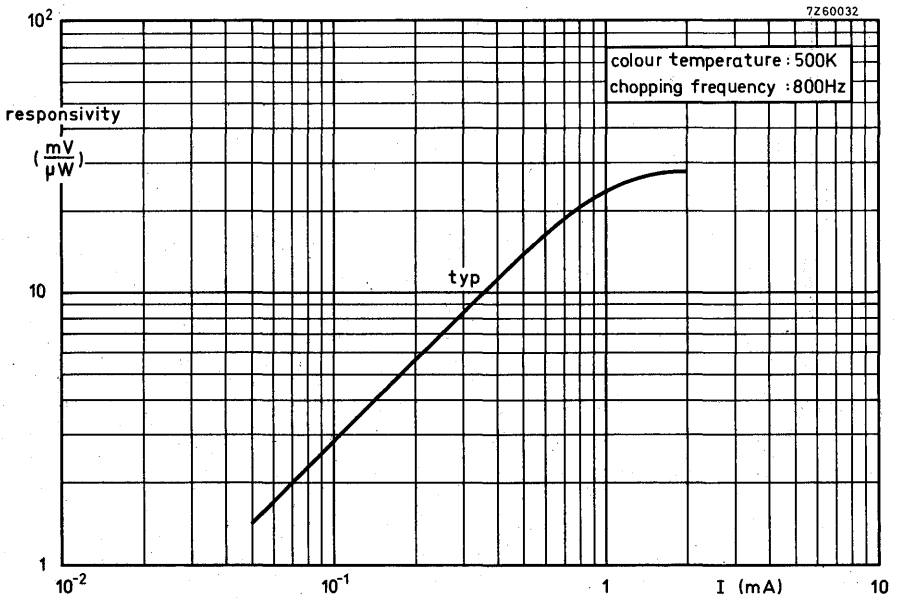
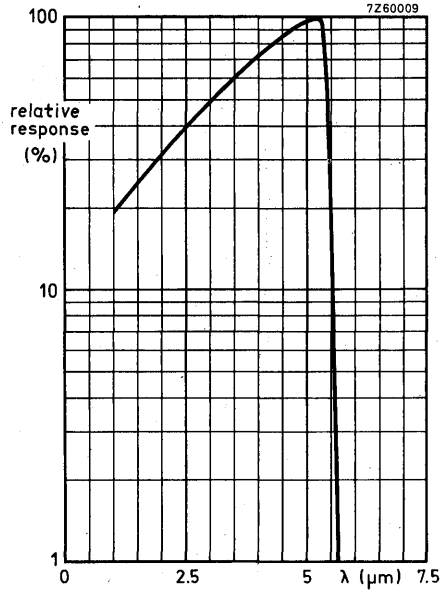

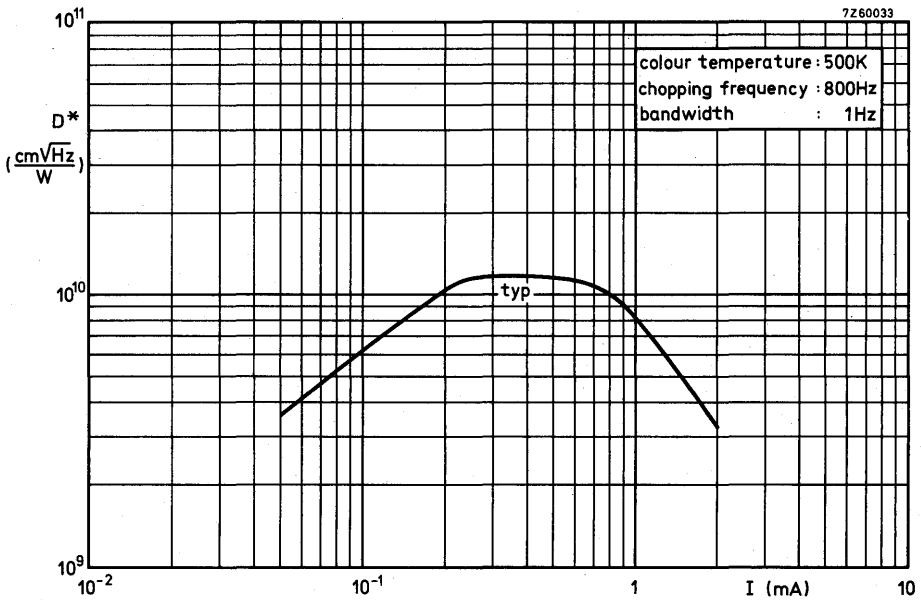
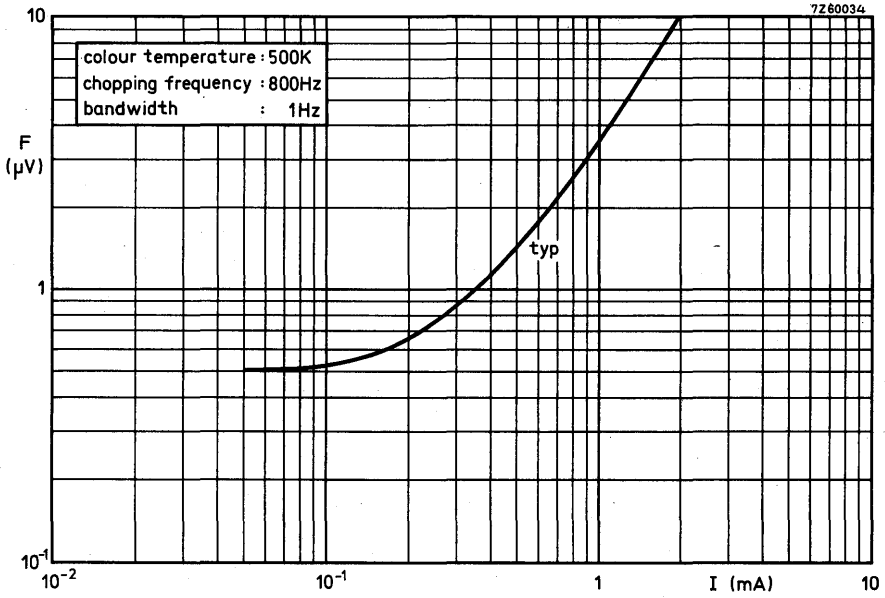

PHOTOCONDUCTIVE CELL

Lead sulphide, chemically deposited, photoconductive cell recommended for room temperature operation.

It is encapsulated in a hermetically sealed TO-5 envelope with an end viewing window. It has a germanium filter to cut off radiation below 1,5 μm and therefore it may be exposed continuously to visible radiation.

QUICK REFERENCE DATA

Peak spectral response	λ_m	typ.	1,9	μm
Spectral response range	λ		1,5 to 3,0	μm
Responsivity (2,0 μm , 800 Hz)		>	200	mA/W
Responsivity (500K, 800 Hz)		>	2,0	mA/W
D^* (500K, 800 Hz, 1 Hz)		>	$1,0 \times 10^8$	$\text{cm}\sqrt{\text{Hz/W}}$
Time constant		typ.	250	μs
Sensitive area			1,0 x 1,0	mm^2

MECHANICAL DATA

Dimensions in mm

Fig. 1 TO-5 (except for window).

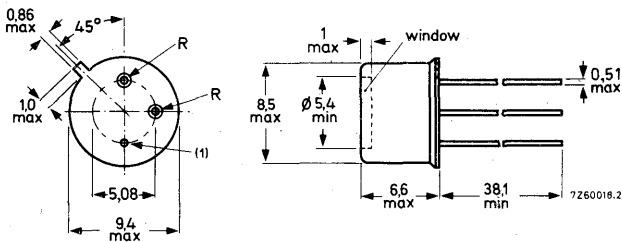

(1) Connected to case

RATINGS Limiting values in accordance with the Absolute Maximum System (IEC 134)

<u>Power dissipation</u>	P	max.	20	mW
<u>Temperatures</u>				
Storage temperature	T _{stg}	-20 to +50	°C	
Operating ambient temperature	T _{amb}	max.	50	°C

CHARACTERISTICS at T_{amb} = 20 °C (see notes on pages 3 and 4)

<u>Peak spectral response</u>	λ_m	typ.	1.9	μm
<u>Spectral response range</u>	λ		1.5 to 3.0	μm
<u>Cell resistance</u>	r_l	>	200	k Ω
		typ.	600	k Ω
<u>Time constant</u>		typ.	250	μs
		<	400	μs

Performance

1. Black body source measurement

colour temperature : 500 K
 chopping frequency : 800 Hz
 bandwidth : 1 Hz

Responsivity	>	2.0	mA/W
D*	>	1.0 x 10 ⁸	cm $\sqrt{\text{Hz/W}}$
N. E. P.	<	1.0	nW

2. Monochromatic source measurement

radiation : 2.0 μm
 chopping frequency : 800 Hz
 bandwidth : 1 Hz

Responsivity	>	200	mA/W
D*	>	1.0 x 10 ¹⁰	cm $\sqrt{\text{Hz/W}}$
N. E. P.	<	10	pW

NOTES

1. Test conditions

The cell is operated at a temperature of 20 °C. The sensitive element is situated at a distance of 264 mm from a black body source limited by an aperture of 3 mm diameter.

The radiation path is interrupted at 800 Hz by a chopper blade at ambient temperature. Under these conditions the r. m. s. power at the element (chopping factor 2, 2) is 4,5 μW/cm².

A bias voltage of 24 V is applied to the cell. Measurements of the detector output are made using a low value resistive load, followed by a current pre-amplifier, as shown below. The output is fed into an amplifier tuned to 800 Hz with a bandwidth of 50 Hz.

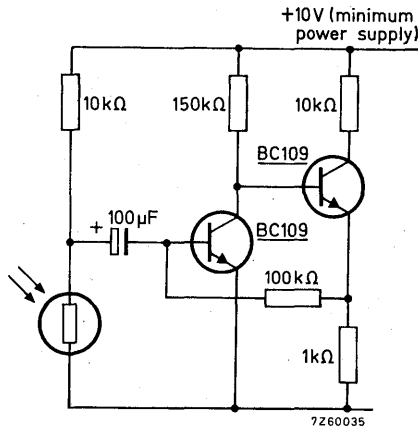

2. D* and N.E.P.

These are figures of merit for the materials of detectors. The detectivity D* is defined in the expression:

$$D^* = \frac{V_s}{V_n} \frac{\sqrt{A(\Delta f)}}{W}$$

- where: V_s = signal voltage across detector terminals
- V_n = noise voltage across detector terminals
- A = detector area
- (Δf) = bandwidth of measuring amplifier
- W = radiation power incident on detector sensitive element in r. m. s. watts.

The Noise Equivalent Power (N.E.P.) is related to D* by the expression:

$$N.E.P. = \frac{\sqrt{A}}{D^*}$$

NOTES (continued)

3. Time constant

Detector time constant figures are based on the response to a step function in the incident radiation. Quoted times indicate the interval between the moment the radiation is cut off and the output falling to 63% of its peak value.

4. a. Variation of performance with bias

Both signal and noise vary with bias in this type of cell. At bias levels at which the cell dissipation is less than 2.5 mW the maximum level of D^* is maintained. At higher levels the noise increases more rapidly than the signal so that although the responsivity increases, D^* falls. The maximum responsivity typically occurs at a dissipation level of 10 mW, beyond which heating occurs with a consequent reduction in responsivity.

b. Variation of performance with temperature/life

Resistance, responsivity and D^* are dependent on the previous temperature/life history of the cell. The quoted values are the minimum which may be expected after storage or operation up to 35 °C. These values may decrease by 50% after storage or operation at temperatures up to the absolute maximum temperature of 50 °C.

5. Recommended operating conditions

In order to minimise the effects of parameter variations with temperature and life it is recommended that a constant voltage bias is used. A suitable circuit is shown on page 3. With this mode of operation the signal is the short-circuit current, which is related to the open-circuit cell voltage by the expression:

$$V_{oc} = I_{sc} \times r_l$$

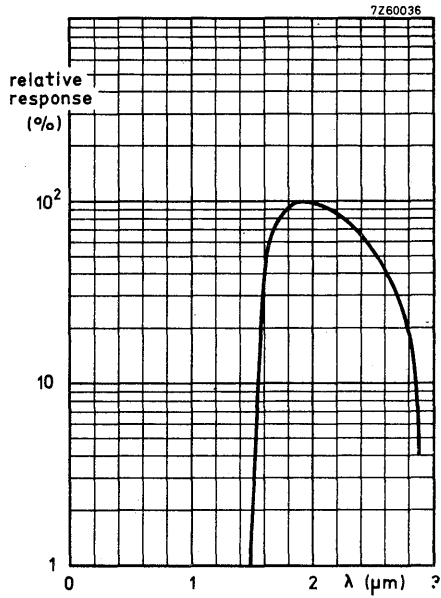

PYROELECTRIC INFRARED DETECTORS

This is an infrared sensitive device, combined with a pre-amplifier which is stabilized to overcome d.c.drift due to thermal changes. It is hermetically sealed with a choice of window in a low-profile TO-5 can.

QUICK REFERENCE DATA

	RPY86	RPY87	
Spectral response	6.5 to 14	1.0 to 15	μm
Responsivity,	(10 μm , 10)	(6 μm , 10)	
typ.	640	500	VW ⁻¹
Noise Equivalent Power (N. E. P.),	(10 μm , 10, 1)	(6 μm , 10, 1)	
typ.	1.3×10^{-9}	1.7×10^{-9}	WHZ ^{-1/2}
Element dimensions	2 x 1		mm
Field of view (to centre of element)			
typ.	145		degrees
Operating voltage	9		V
Operating frequency	0.01 to 1000		Hz

MECHANICAL DATA

Dimensions in mm

SOT-49D

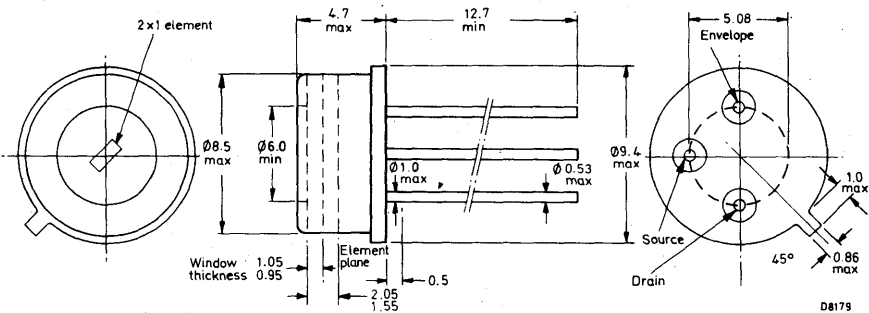

Soldering

1. When making soldered connections to the leads, a thermal shunt must be used.
2. It is essential that any mains operated soldering iron used should be both screened and earthed. Failure to observe these precautions could lead to the introduction of line voltage and possible damage to the device.

RATINGS Limiting values in accordance with the Absolute Maximum System (IEC134)

Operating voltage at 100 °C	max.	30	V
Temperature, operating	max.	+100	°C
	min.	-20	°C
Temperature, storage	max.	+100	°C
	min.	-20	°C

CHARACTERISTICS (at 25 ± 3°C and with recommended test circuit)

<u>RPY86</u>	min.	typ.	max.	
N.E.P. (500 K, 10, 1)		2.0×10^{-9}		WHz ^{-½}
N.E.P. (10 μm, 10, 1) 1)		1.3×10^{-9}	3×10^{-9}	WHz ^{-½}
Responsivity (500 K, 10)		430		VW-1
Responsivity (10 μm, 10) 1)		640		VW-1
Spectral response	6.5 ± 0.5		>14	μm
Field of view (from centre of element)	135	145	155	degrees
Operating voltage 2)	8	9	10	V

RPY87

N.E.P. (500 K, 10, 1) or (6 μm, 10, 1)		1.7×10^{-9}	3×10^{-9}	WHz ^{-½}
Responsivity (500 K, 10) or (6 μm, 10)		500		VW-1
Spectral response	1.0		>15	μm
Field of view (from centre of element)	135	145	155	degrees
Operating voltage 2)	8	9	10	V

1) These characteristics apply throughout the spectral response range.

2) The detector will operate outside the quoted range but may have a degraded performance.

3) For performance as a function of frequency, see pages 6 and 8.

Test circuit

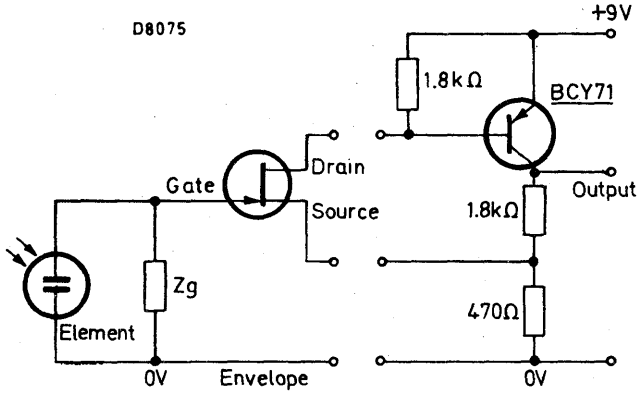

OPERATING NOTES

1. The detector is supplied with a black plastic cap to protect the window. This cap must be removed before operation.
2. The case potential must not be allowed to become positive with respect to the other two terminals.
3. The shape of the electrical output waveform is the integral of the incident radiation waveform.
4. It is inadvisable to operate the detector at mains related frequencies.
5. To avoid the possibility of optical microphony, the detector must be firmly mounted.
6. Use recommended circuit for low noise operation.
7. An increase in temperature of the element will produce a negative going signal at the output.

DEFINITIONS

1. N.E.P. (Noise Equivalent Power), $WHz^{-1/2}$
 This is the r.m.s. value of the incident, chopped, radiant power necessary to produce an r.m.s. signal to r.m.s. noise ratio of unity. The r.m.s. noise refers to the value calculated for unit square root bandwidth $VHz^{-1/2}$
2. Responsivity VW^{-1}
 This is the ratio of the r.m.s. signal in volts to the r.m.s. value of the incident, chopped, radiant power.

APPLICATION INFORMATION

1. Optional additional stage for extra gain.

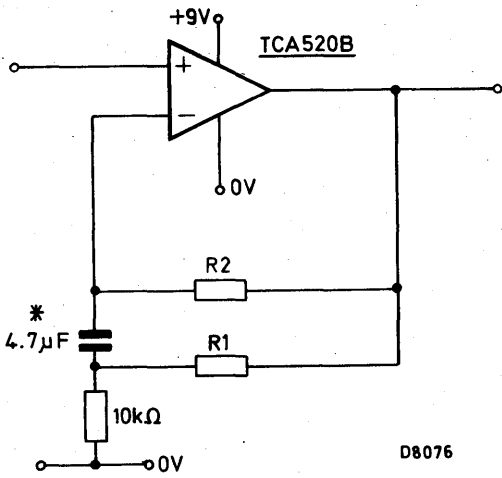

*this capacitor must be a low leakage type e.g. our 344 series

D8076

The following table gives recommended component values for various gains.

Gain	R1	R2
×	kΩ	MΩ
50	560	5.6
20	220	2.2
10	100	1.0

2. The pyroelectric element may be considered as a capacitor whose charge state changes with temperature. It also behaves as a normal capacitor, i.e. its voltage changes with charge. Thus a change of temperature results in a change of charge. It can be seen that, for a given change in amplitude of incident radiation, the resulting change in temperature will decrease as the chopping frequency increases. Thus the voltage change will also decrease with frequency. In addition, there is a 90° phase lag between the thermal and electrical signals. The voltage signal therefore becomes the integral of the radiation signal.

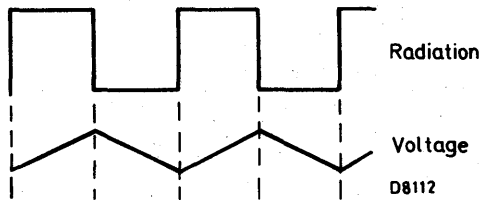

D8112

3. Temperature slew

The FET used with a pyroelectric detector requires a gate leakage resistor to earth in parallel with the element. This stabilizes its working point. The pyroelectric voltage appearing across this resistor is proportional to the rate of change of temperature.

To ensure a low level of noise current from this resistor, its value should be of the order of $3 \times 10^{10} \Omega$. When the temperature slew rate is $1^\circ\text{C}/\text{minute}$, the pyroelectric voltage produced is 1 Volt. In a system which is designed to sense microvolts, this is almost certain to cause overload and any a.c. signal superimposed on this d.c. shift will be lost.

Our detectors incorporate a bleed system which acts progressively on the d.c. shift caused by temperature slew. The law is logarithmic.

Thus a slew rate of $0.1^\circ\text{C}/\text{minute}$ may produce an offset across the sensing element of 200 millivolts, $1^\circ\text{C}/\text{minute}$ 280 millivolts and $10^\circ\text{C}/\text{minute}$ 360 millivolts.



RPY86

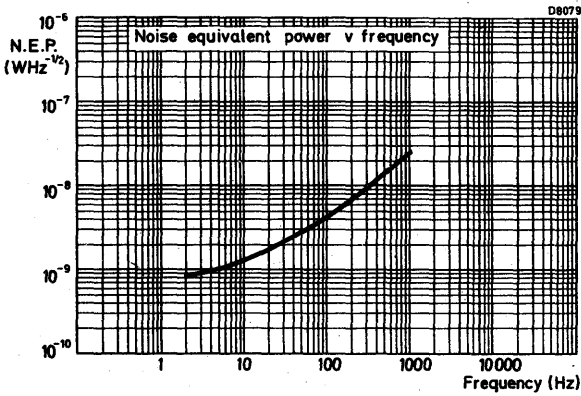
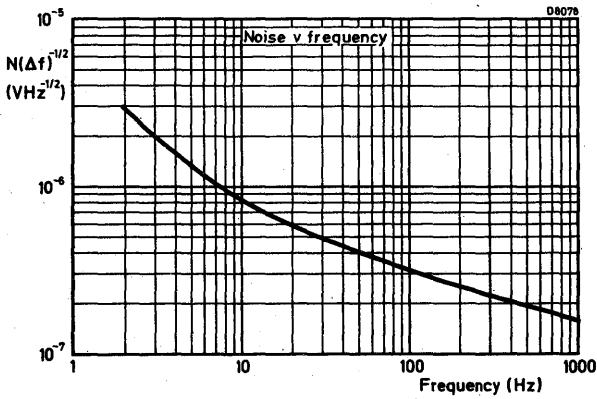
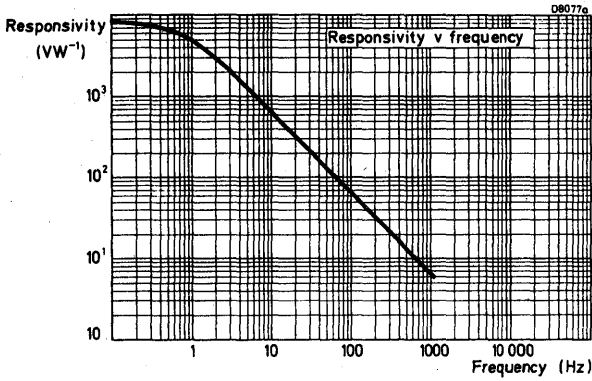

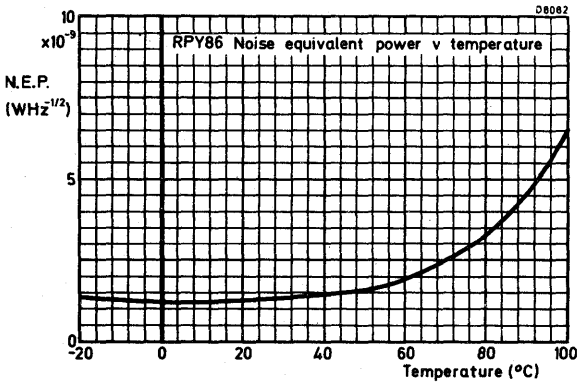
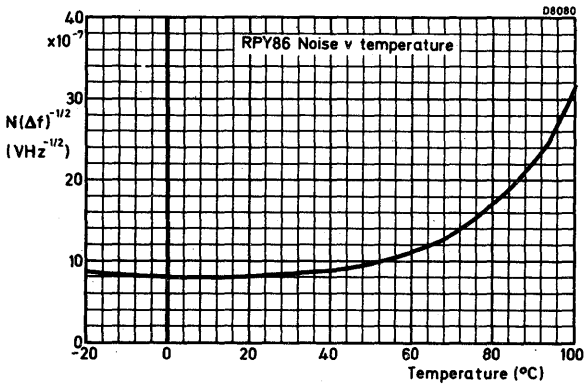
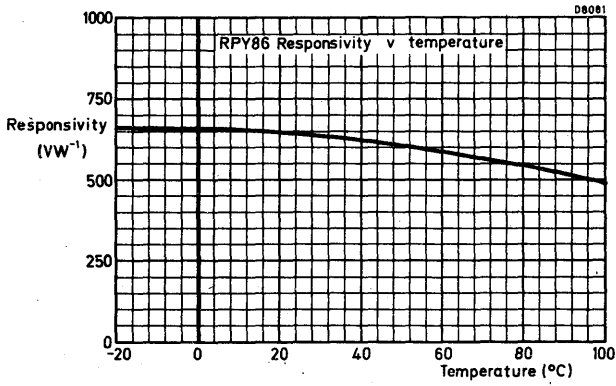

RPY87

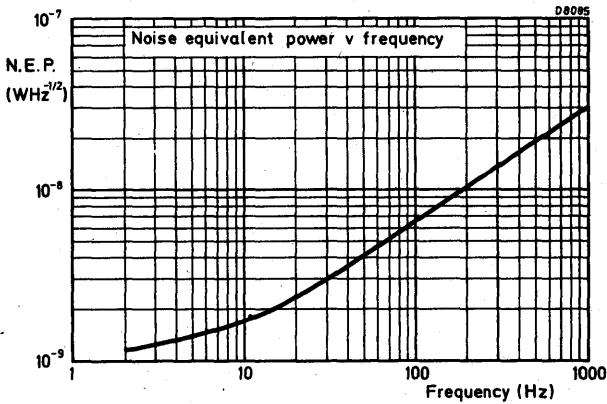
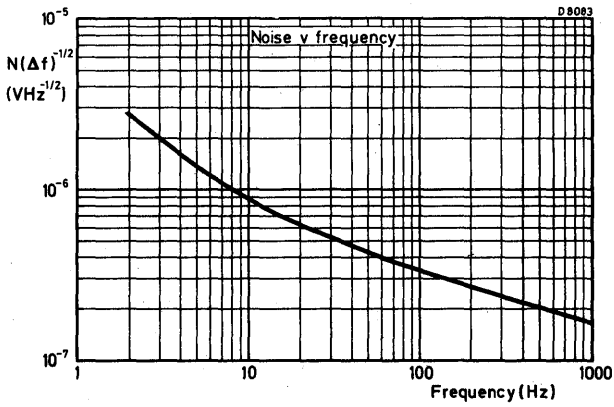
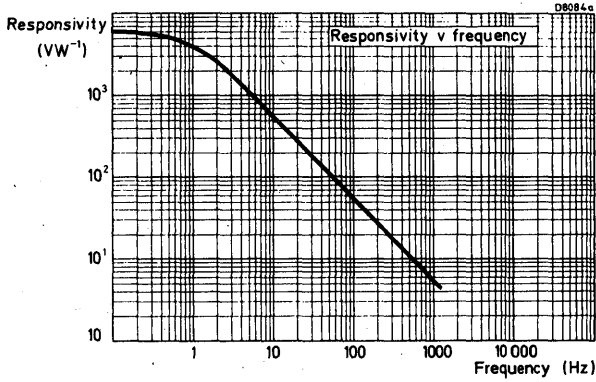

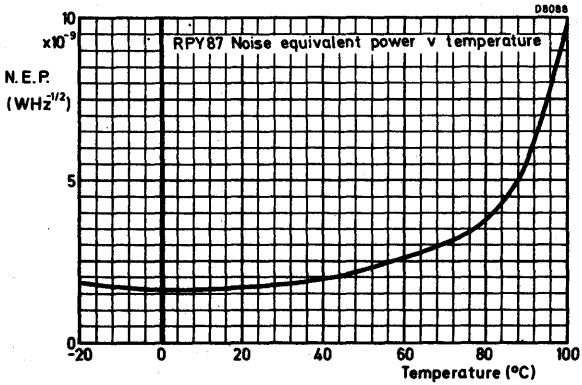
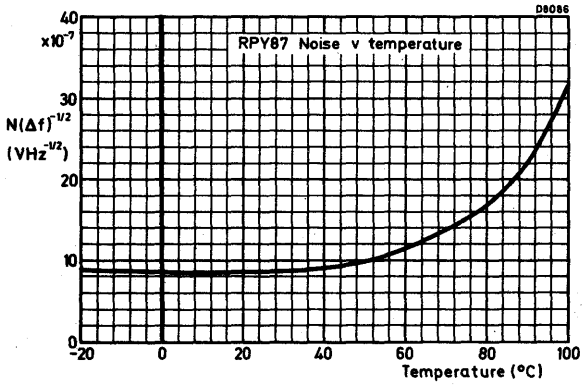
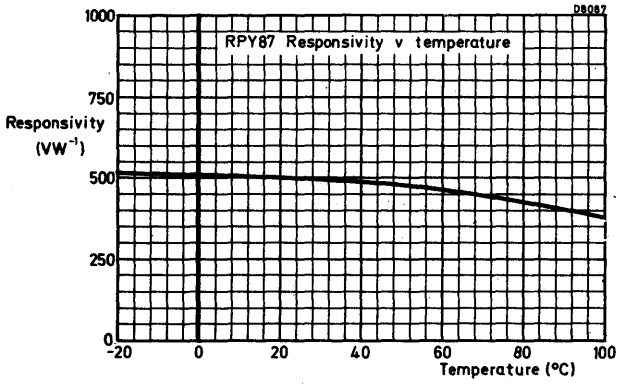

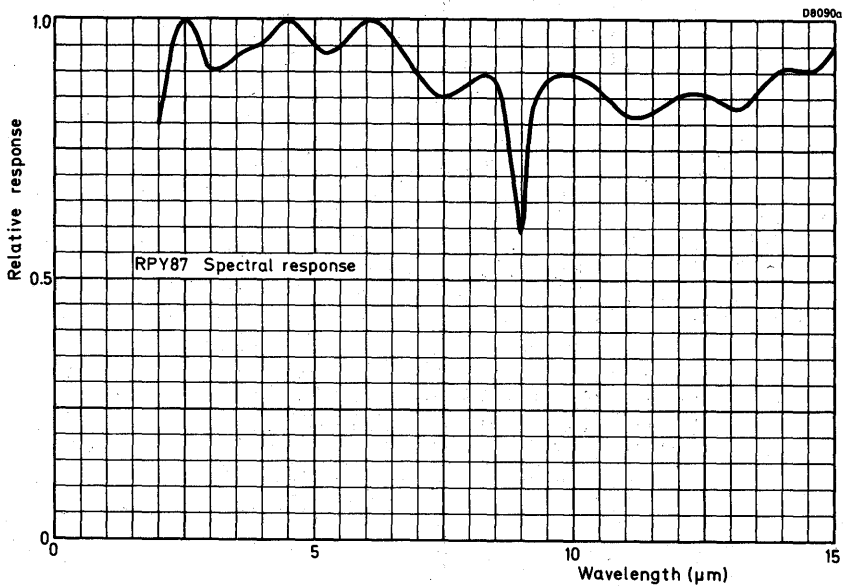
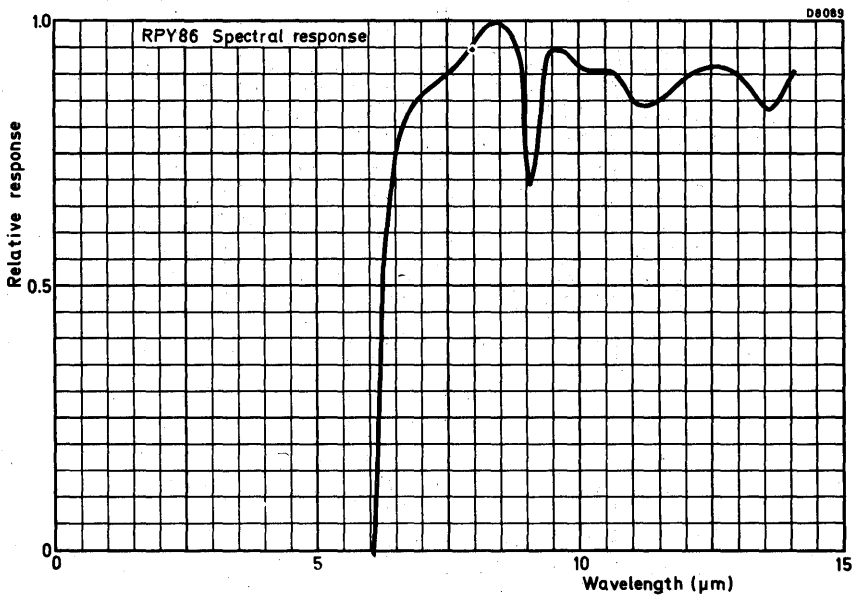

PYROELECTRIC INFRARED DETECTORS

This is an infrared sensitive device, combined with a pre-amplifier which is stabilized to overcome d.c. drift due to thermal changes. It is hermetically sealed with a choice of window in a low-profile TO-5 can.

QUICK REFERENCE DATA

	RPY88	RPY89	
Spectral response	6.5 to 14	1.0 to 15	μm
Responsivity, typ.	(10 μm , 10) 320	(6 μm , 10) 250	VW-1
Noise Equivalent Power (N.E.P.) typ.	(10 μm , 10, 1) 2.0×10^{-9}	(6 μm , 10, 1) 2.5×10^{-9}	WHZ- $\frac{1}{2}$
Element dimensions		2×2	mm
Field of view (to centre of element) typ.		145	degrees
Operating voltage		9	V
Operating frequency		0.01 to 1000	Hz

MECHANICAL DATA

Dimensions in mm

SOT-49D

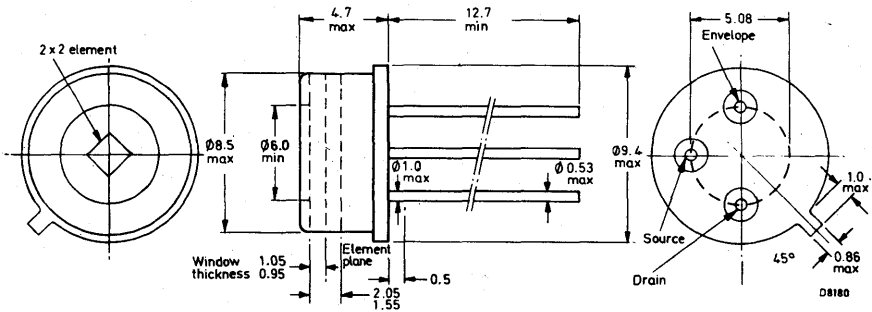

Soldering

1. When making soldered connections to the leads, a thermal shunt must be used.
2. It is essential that any mains operated soldering iron used should be both screened and earthed. Failure to observe these precautions could lead to the introduction of line voltage and possible damage to the device.

RATINGS Limiting values in accordance with the Absolute Maximum System (IEC134)

Operating voltage at 100 °C	max.	30	V
Temperature, operating	max.	+100	°C
	min.	-20	°C
Temperature, storage	max.	+100	°C
	min.	-20	°C

CHARACTERISTICS (at 25 ± 3 °C and with recommended test circuit)

<u>RPY88</u>	min.	typ.	max.	
N.E.P. (500 K, 10, 1)		3.0×10^{-9}		WHz ^{-½}
N.E.P. (10 μm, 10, 1) 1)		2.0×10^{-9}	3×10^{-9}	WHz ^{-½}
Responsivity (500 K, 10)		215		VW ⁻¹
Responsivity (10 μm, 10) 1)		320		VW ⁻¹
Spectral response	6.5 ± 0.5		>14	μm
Field of view (from centre of element)	135	145	155	degrees
Operating voltage 2)	8	9	10	V
<u>RPY89</u>				
N.E.P. (500 K, 10, 1) or (6 μm, 10, 1)		2.5×10^{-9}	3×10^{-9}	WHz ^{-½}
Responsivity (500 K, 10) or (6 μm, 10)		250		VW ⁻¹
Spectral response	1.0		>15	μm
Field of view (from centre of element)	135	145	155	degrees
Operating voltage 2)	8	9	10	V

1) These characteristics apply throughout the spectral response range.

2) The detector will operate outside the quoted range but may have a degraded performance.

3) For performance as a function of frequency, see pages 6 and 8.

Test circuit

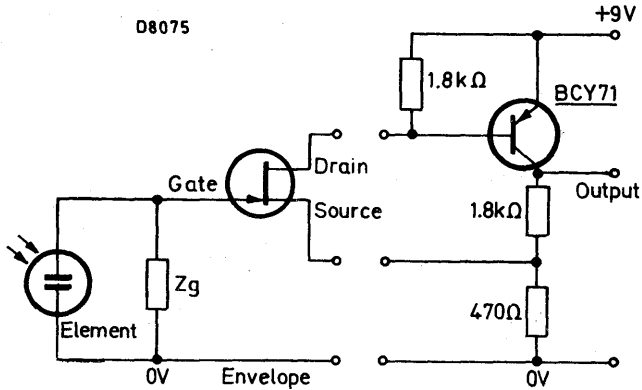

OPERATING NOTES

1. The detector is supplied with a black plastic cap to protect the window. This cap must be removed before operation.
2. The case potential must not be allowed to become positive with respect to the other two terminals.
3. The shape of the electrical output waveform is the integral of the incident radiation waveform.
4. It is inadvisable to operate the detector at mains related frequencies.
5. To avoid the possibility of optical microphony, the detector must be firmly mounted.
6. Use recommended circuit for low noise operation.
7. An increase in temperature of the element will produce a negative going signal at the output.

DEFINITIONS

1. N.E.P. (Noise Equivalent Power), $\text{WHz}^{-1/2}$
This is the r.m.s. value of the incident, chopped, radiant power necessary to produce an r.m.s. signal to r.m.s. noise ratio of unity. The r.m.s. noise refers to the value calculated for unit square root bandwidth $\text{VHz}^{-1/2}$
2. Responsivity VW^{-1}
This is the ratio of the r.m.s. signal in volts to the r.m.s. value of the incident, chopped, radiant power.

APPLICATION INFORMATION

- Optional additional stage for extra gain.

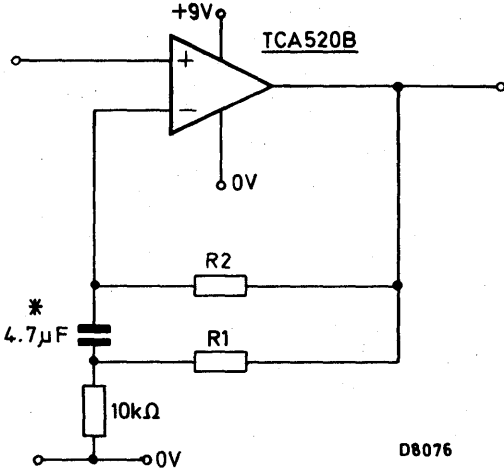

*this capacitor must be a low leakage type e.g. our 344 series

D8076

The following table gives recommended component values for various gains.

Gain	R1	R2
×	kΩ	MΩ
50	560	5.6
20	220	2.2
10	100	1.0

- The pyroelectric element may be considered as a capacitor whose charge state changes with temperature. It also behaves as a normal capacitor, i.e. its voltage changes with charge. Thus a change of temperature results in a change of charge. It can be seen that, for a given change in amplitude of incident radiation, the resulting change in temperature will decrease as the chopping frequency increases. Thus the voltage change will also decrease with frequency. In addition, there is a 90° phase lag between the thermal and electrical signals. The voltage signal therefore becomes the integral of the radiation signal.

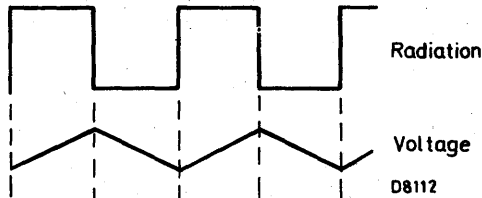

D8112

3. Temperature slew

The FET used with a pyroelectric detector requires a gate leakage resistor to earth in parallel with the element. This stabilizes its working point. The pyroelectric voltage appearing across this resistor is proportional to the rate of change of temperature.

To ensure a low level of noise current from this resistor, its value should be of the order of $3 \times 10^{10} \Omega$. When the temperature slew rate is $1^\circ\text{C}/\text{minute}$, the pyroelectric voltage produced is 1 Volt. In a system which is designed to sense microvolts, this is almost certain to cause overload and any a. c. signal superimposed on this d. c. shift will be lost.

Our detectors incorporate a bleed system which acts progressively on the d. c. shift caused by temperature slew. The law is logarithmic.

Thus a slew rate of $0.1^\circ\text{C}/\text{minute}$ may produce an offset across the sensing element of 200 millivolts, $1^\circ\text{C}/\text{minute}$ 280 millivolts and $10^\circ\text{C}/\text{minute}$ 360 millivolts.



RPY88

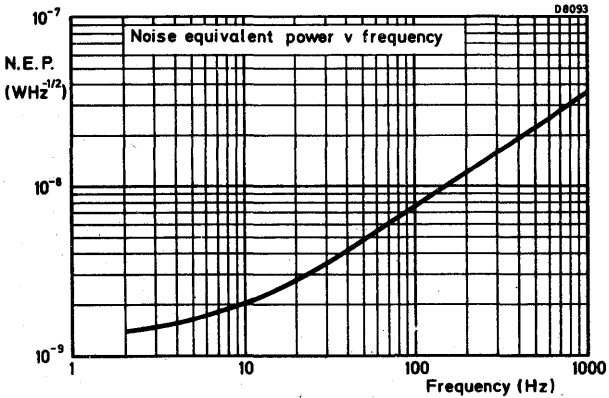
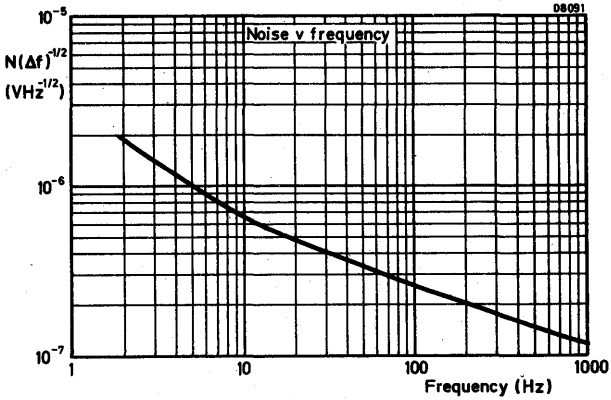
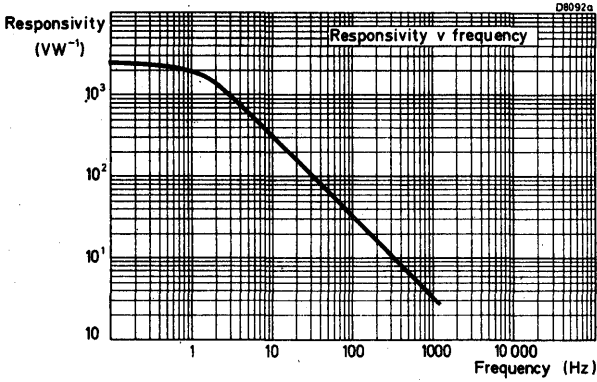

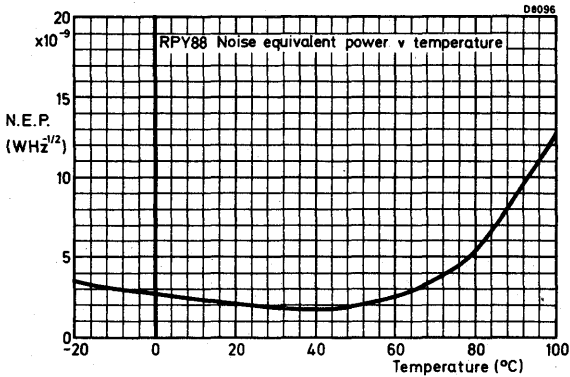
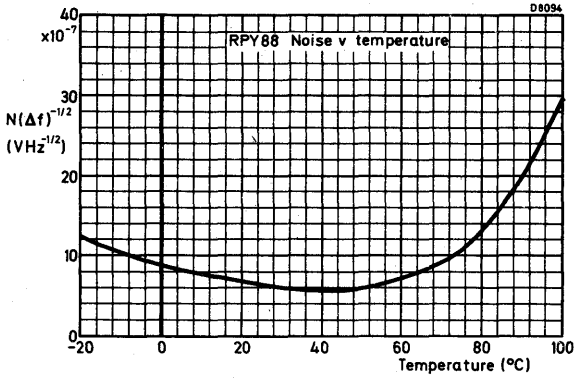
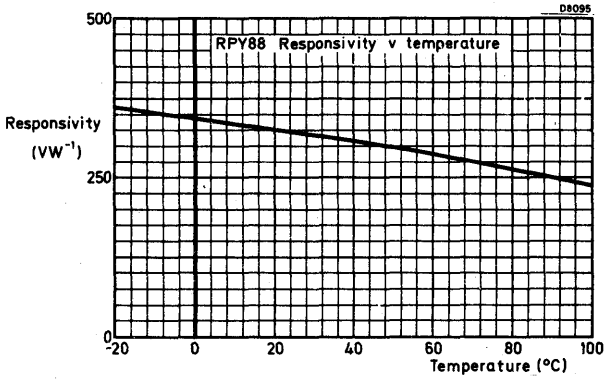

RPY89

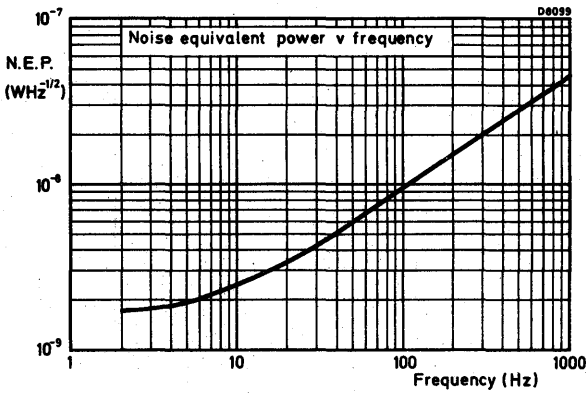
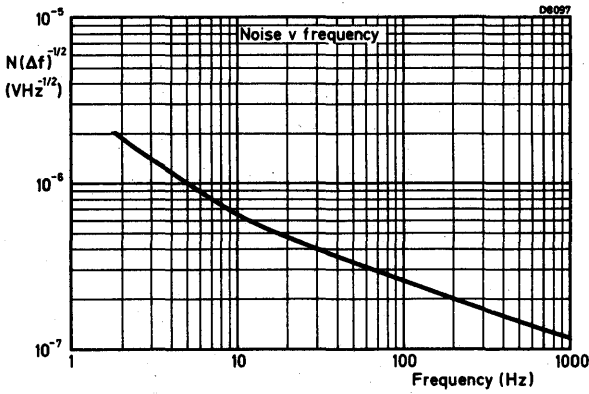
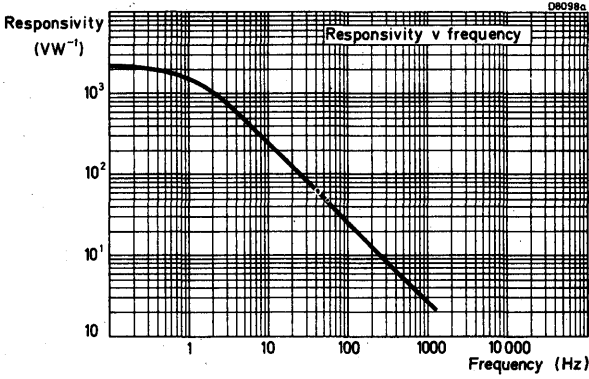

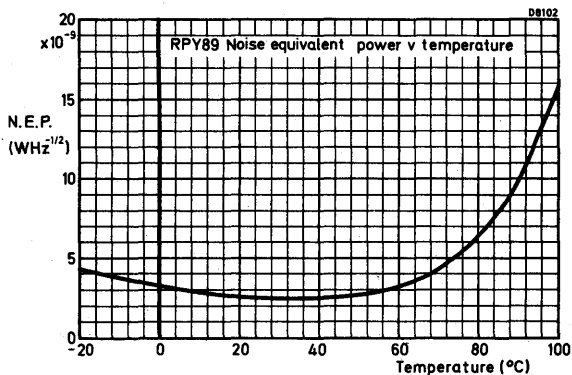
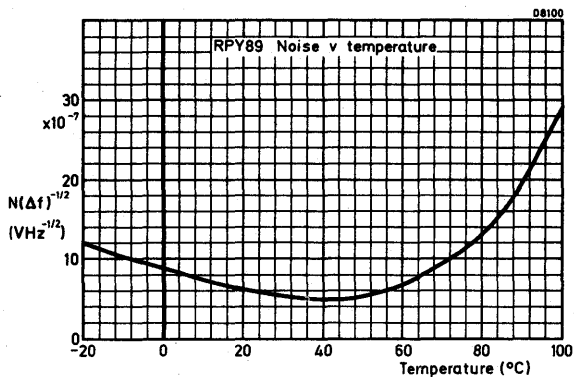
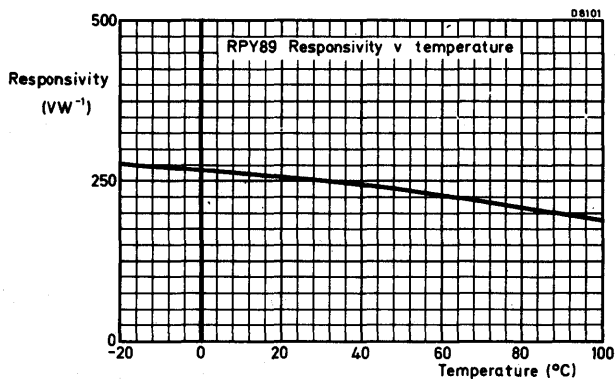

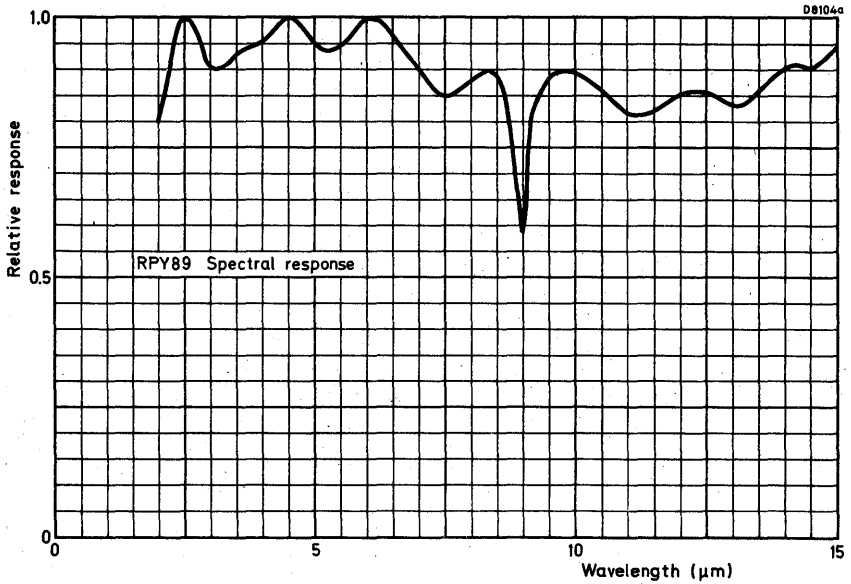
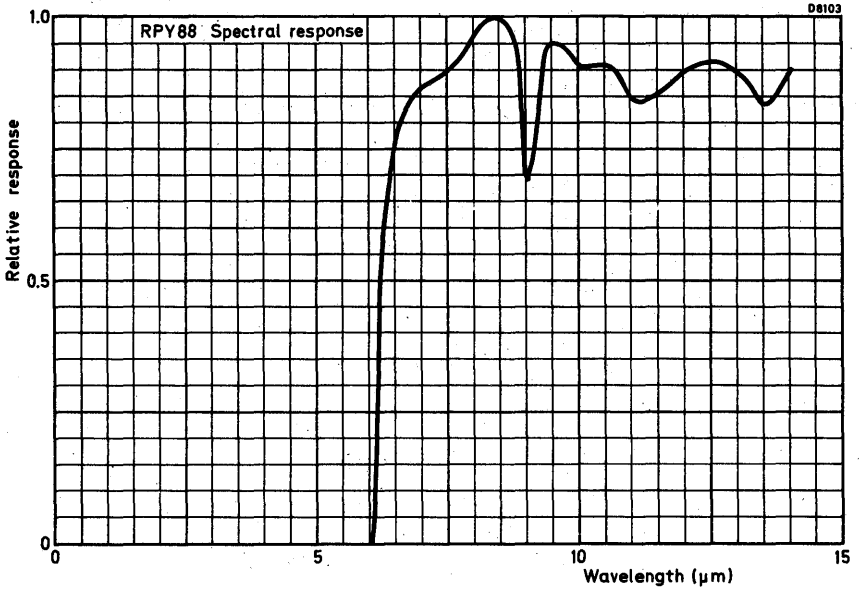

PHOTOCONDUCTIVE CELL

Evaporated lead sulphide photoconductive cell with sensitive element mounted in a glass dewar, encapsulated in an envelope for room temperature operation.

Also available without envelope for cooled operation.

The cells are intended for use with pulsed or modulated radiation.

QUICK REFERENCE DATA

Peak spectral response	λ_m	2,2 μm
Spectral response range	λ	0,3 to 3,5 μm
Internal resistance	r_i	typ. 1,5 $\text{M}\Omega$
Responsivity (radiation 2,0 μm)		typ. 80 $\text{mV}/\mu\text{W}$
D^* (2,0 μm , 800 Hz, 1 Hz)		typ. 4×10^{10} $\text{cm}\sqrt{\text{Hz}/\text{W}}$
Time constant		typ. 100 μs
Sensitive area		6,0 x 6,0 mm^2

MECHANICAL DATA

Dimensions in mm

Fig. 1.

Cooled version

Code No.
9332 401 30

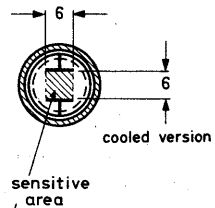
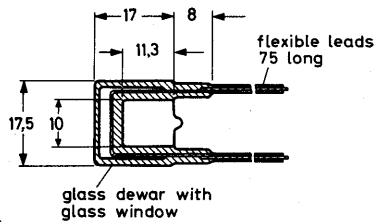

Encapsulated version

Code No.
9330 200 30

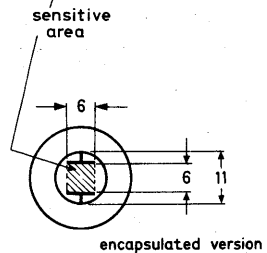
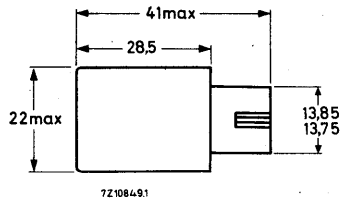

RATINGS Limiting values in accordance with the Absolute Maximum System (IEC 134)

<u>Voltage</u> (bidirectional)	V	max.	250 V
<u>Current</u> (bidirectional)	I	max.	0.5 mA
<u>Temperatures</u>			
Storage temperature	encapsulated version	T_{stg}	-55 to +60 °C
	cooled version	T_{stg}	-80 to +60 °C
Operating ambient temperature	T_{amb}	max.	60 °C

CHARACTERISTICS at $T_{amb} = 20\text{ °C}$ (see note 1 on page 3)

<u>Peak spectral response</u>	λ_m	2.2 μm
<u>Spectral response range</u>	λ	0.3 to 3.5 μm
<u>Internal resistance</u>	r_i	typ. 1.5 $\text{M}\Omega$
		1.0 to 4.0 $\text{M}\Omega$
<u>Time constant</u>	typ.	100 μs
<u>Noise voltage</u>	typ.	8.5 μV
<u>Performance</u>		

1. Black body source

colour temperature : 500 K
 chopping frequency : 800 Hz
 bandwidth : 1 Hz

Responsivity	>	0.2 $\text{mV}/\mu\text{W}$
	typ.	1.3 $\text{mV}/\mu\text{W}$
D^*	>	$2.0 \times 10^8 \text{ cm}\sqrt{\text{Hz}/\text{W}}$
	typ.	$6.5 \times 10^8 \text{ cm}\sqrt{\text{Hz}/\text{W}}$
N.E.P.	typ.	0.92 nW
	<	3.0 nW

2. Monochromatic source

radiation : 2.0 μm
 chopping frequency: 800 Hz
 bandwidth : 1 Hz

Responsivity	typ.	80 $\text{mV}/\mu\text{W}$
D^*	typ.	$4 \times 10^{10} \text{ cm}\sqrt{\text{Hz}/\text{W}}$
N.E.P.	typ.	15 pW

NOTES

1. Test conditions

The characteristics are measured with the cell biased from a 200 V d.c. supply in series with a 1.0 M Ω load resistor. No correction is made for the loading effect of the 1.0 M Ω resistor, i.e. open circuit characteristics are not given.

The sensitive element is situated at a distance of 264 mm a black body source limited by an aperture of 3 mm. The radiation path is interrupted at 800 Hz by a chopper blade at ambient temperature. Under these conditions the r.m.s. power at the element (chopping factor 2.2) is 4.5 μ W/cm².

Measurements of the detector output are made with an amplifier tuned to 800 Hz with a bandwidth of 50 Hz.

2. D* and N.E.P.

These are figures of merit for the materials of detectors.

The detectivity D* is defined in the expression:

$$D^* = \frac{V_S}{V_n} \frac{\sqrt{A(\Delta f)}}{W}$$

where: V_S = signal voltage across detector terminals

V_n = noise voltage across detector terminals

A = detector area

(Δ f) = bandwidth of measuring amplifier

W = radiation power incident on detector sensitive element in r.m.s. watts.

The Noise Equivalent Power (N.E.P.) is related to D* by the expression:

$$\text{N.E.P.} = \frac{\sqrt{A}}{D^*}$$

3. Time constant

Detector time constant figures are based on the response to a step function in the incident radiation. Quoted times indicate the interval between the moment the radiation is cut off and the output falling to 63% of its peak value.

4. Variation of performance with bias current.

Both signal and noise vary with current in this type of cell. At high currents the noise increases more rapidly than the signal, and therefore the signal-to-noise ratio has a peak value at some optimum current, which will vary slightly from cell to cell.

NOTES (continued)**5. Effect of ambient radiation**

Care should be taken to avoid the incidence on the cell of appreciable radiation in the visible range. Such radiation will cause a decrease in the cell resistance and signal as long as the cell is kept cool. Normal daylight can cause this effect if seen for more than a few minutes. Precautions should be taken to prevent visible light reaching the sensitive element via the liquid nitrogen compartment.

6. Warning

Care should be taken to ensure that the device is not allowed to reach room temperature while still biased.

The dewar vessel must always be completely dry before being refilled with liquid nitrogen. In very humid conditions, water vapour may condense at the top of the dewar vessel. Should this occur, the remaining liquid nitrogen should be allowed to boil off, the ice should be removed and precautions taken to avoid a recurrence.

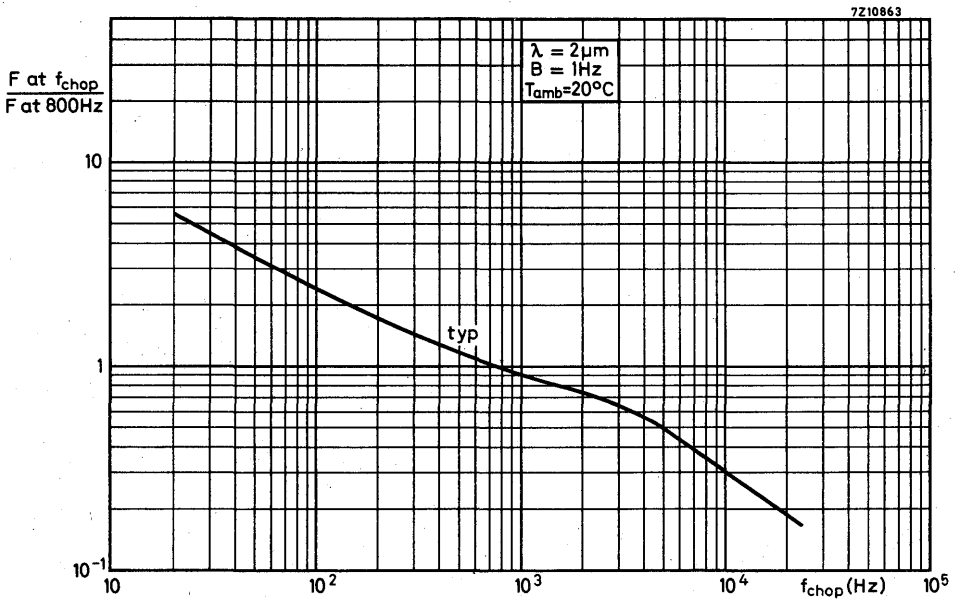
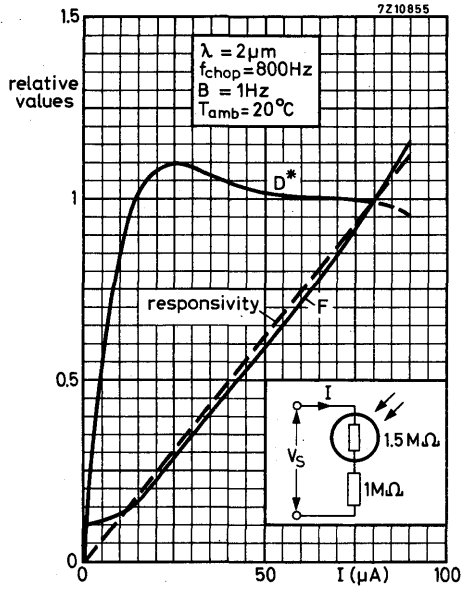
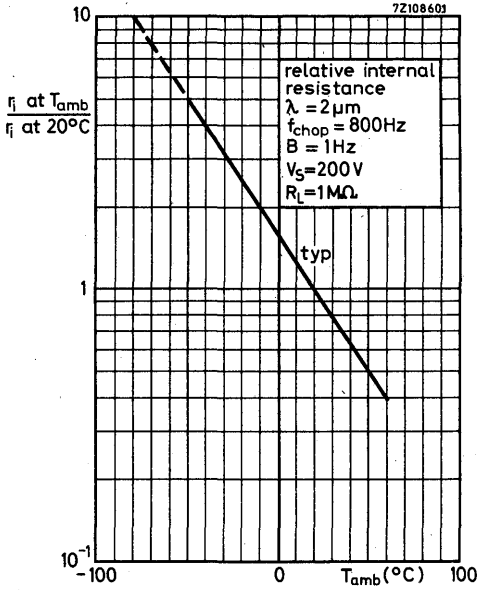

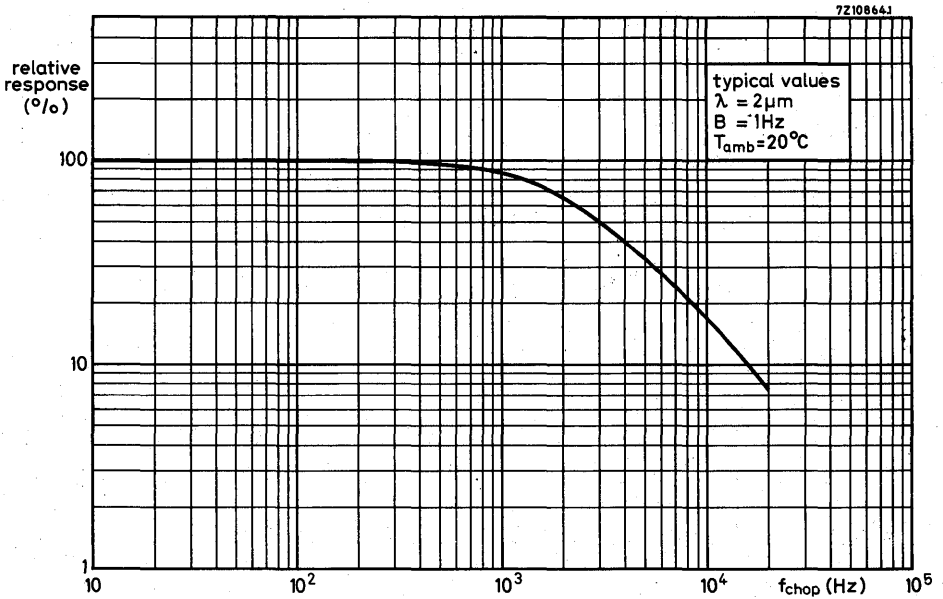
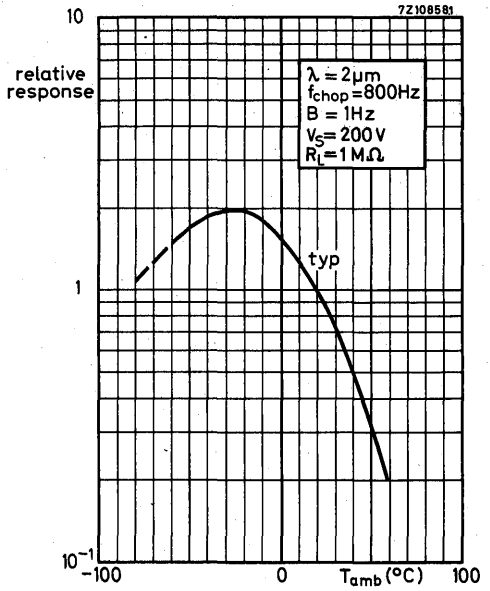
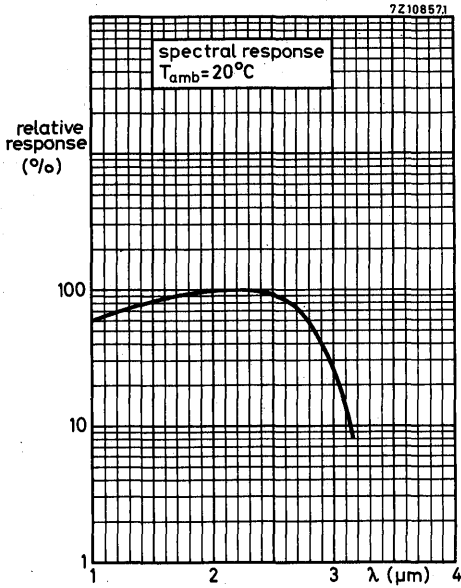

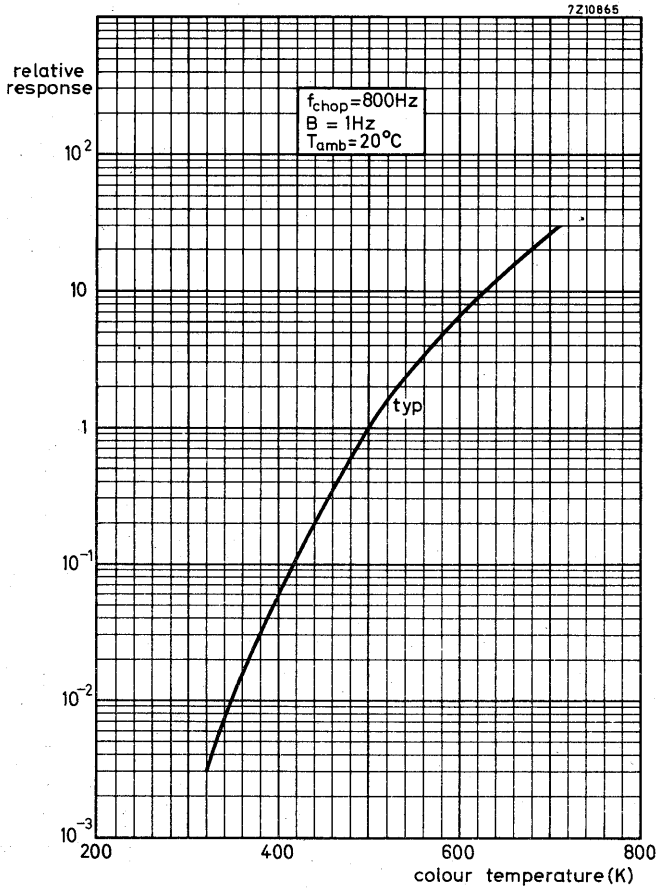

72108561

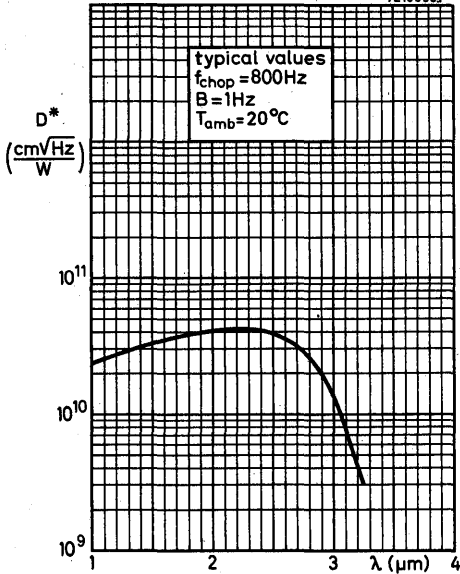

72108591

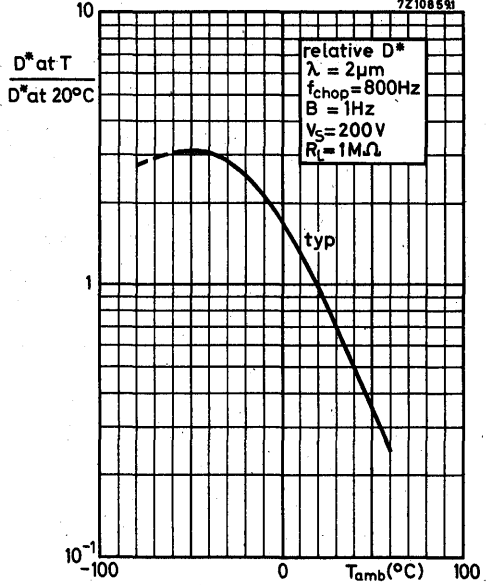

72108611

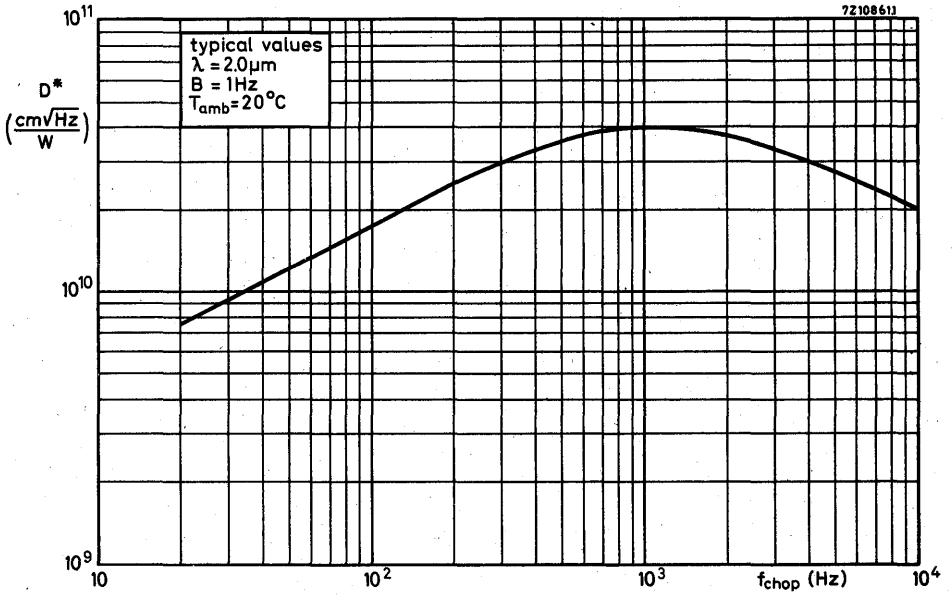

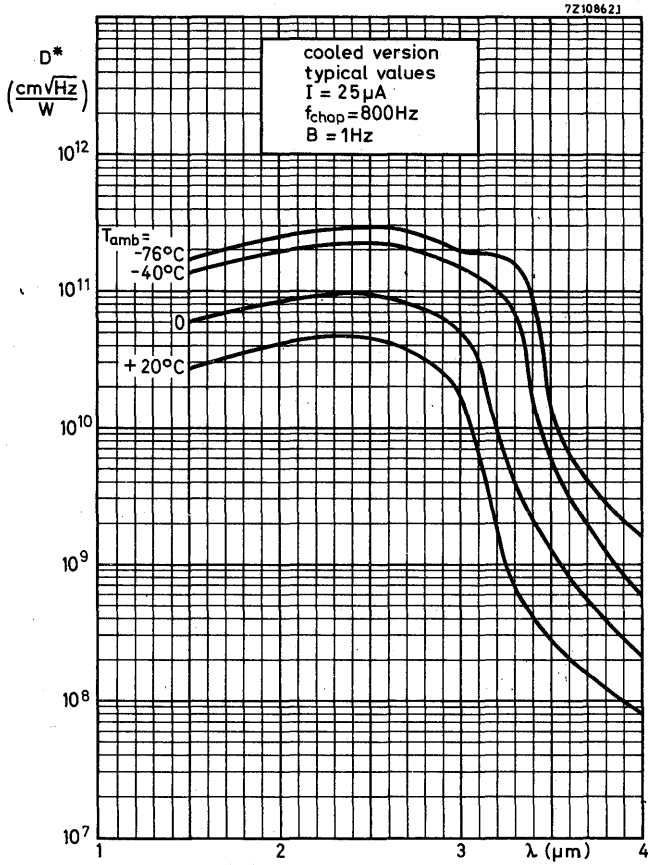



PHOTOCONDUCTIVE DEVICES



LIST OF SYMBOLS

Cell voltage	V
Cell current	I
Illumination current	I_l
Initial illumination current	I_{l0}
Equilibrium illumination current	I_{le}
Dark current	I_d
Initial dark current	I_{d0}
Equilibrium dark current	I_{de}
Illumination resistance	r_l
Initial illumination resistance	r_{l0}
Equilibrium illumination resistance	r_{le}
Dark resistance	r_d
Initial dark resistance	r_{d0}
Equilibrium dark resistance	r_{de}
Current rise time	t_{ri}
Current decay time	t_{fi}
Pulse duration	t_p
Averaging time	t_{av}
Pulse repetition rate	P_{rr}
Illumination sensitivity	N
Illumination response	γ
Voltage response	α
Ambient temperature	T_{amb}
Thermal resistance	R_{th}
Temperature of CdS tablet	T_{tablet}
Colour temperature	$T_c (T_K)$
Dissipation	P
Illumination	E
Initial drift	D_0
Peak value (subscript)	M

GENERAL OPERATIONAL RECOMMENDATIONS PHOTOCONDUCTIVE DEVICES

1. GENERAL

- 1.1 These application directions are valid for all types of photoconductive cells, unless otherwise stated on the individual technical data sheets.
- 1.2 A photoconductive device is a light-sensitive device whose resistance varies with the illumination on the device.
- 1.3 Where the term illumination is used in the following sections it shall be taken to mean the radiant energy which is normally used to excite the device.
- 1.4 Also in the following sections, history is taken to mean the duration of the specified conditions plus a sufficient description of previous conditions.

2. OPERATING CHARACTERISTICS

- 2.1 The data given on the individual technical data sheets are based on the devices being uniformly illuminated.
- 2.2 The illumination resistance is the ratio of the voltage across the device to the current through the device when illumination is applied to the device.
 - 2.2.1 For a particular set of conditions the equilibrium illumination resistance is the illumination resistance after such a time under these conditions that the rate of change of the illumination resistance is less than 1% per 5 minutes.
 - 2.2.2 For a particular set of conditions the initial illumination resistance is the first virtually constant value of the illumination resistance after a period of storage or other operating conditions.
The initial-illumination resistance usually occurs after a few seconds under the specified conditions.
- 2.3 The illumination current is the current which passes when a voltage and illumination are applied to the device.
 - 2.3.1 For a particular set of conditions the equilibrium illumination current is the illumination current after such a time under these conditions that the rate of change of the illumination current is less than 1% per 5 minutes.

- 2.3.2 For a particular set of conditions the initial illumination current is the first virtually constant value of the illumination current after a period of storage or other operating conditions. The initial illumination current usually occurs after a few seconds under the specified conditions.

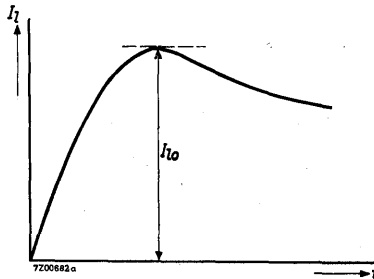

- 2.4 The dark resistance is the resistance of the device in the absence of illumination.
- 2.4.1 For a particular set of conditions the equilibrium dark resistance is the dark resistance after such a time under these conditions that the rate of change of the dark resistance is less than 2% per 5 minutes.
- 2.4.2 For a particular set of conditions the initial dark resistance is the dark resistance after a specified time under these conditions following a specified history.
- 2.5 The dark current is the current which passes when a voltage is applied to the device in the absence of illumination.
- 2.5.1 For a particular set of conditions the equilibrium dark current is the dark current after such a time under these conditions that the rate of change of the dark current is less than 2% per 5 minutes.
- 2.5.2 For a particular set of conditions the initial dark current is the dark current after a specified time under these conditions immediately following a specified history.

- 2.6.1 For a particular set of conditions and history the current rise time is the time taken for the current through the device to rise to 90% to its initial illumination current measured from the instant of starting the illumination.

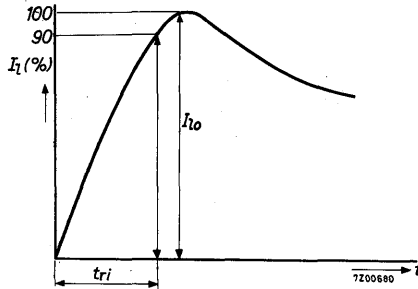

- 2.6.2 For a particular set of conditions and history the current decay time is the time taken for the current through the device to fall to 10% of its value at the instant of stopping the illumination, measured from that instant.

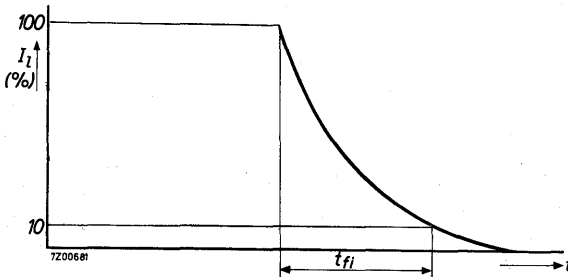

- 2.7 The illumination sensitivity is the quotient of illumination current by the incident illumination.
- 2.8 The illumination resistance (current) temperature response is the relationship between the illumination resistance (current) and the ambient temperature of the device under constant illumination and voltage conditions.
- 2.9 For a particular set of conditions the initial drift is the difference between the equilibrium and initial illumination current, expressed as a percentage of the initial illumination current.
- 2.10 The illumination response is the relationship between the initial illumination resistance and the illumination, defined as $\frac{\Delta \log r_{l0}}{\Delta \log E}$

3. THERMAL DATA

3.1 Ambient temperature. The ambient temperature of a device is the temperature of the surrounding air of that device in its practical situation, which means that other elements in the same space or apparatus must have their normal maximum dissipation and that the same apparatus envelope must be used. This ambient temperature can normally be measured by using a mercury thermometer the mercury container of which has been blackened, placed at a distance of 5 mm from the envelope in the horizontal plane through the centre of the effective area of the CdS tablet.

It shall be exposed to substantially the same radiant energy as that incident on the CdS tablet.

3.2 The thermal resistance of a device is defined as the temperature difference between the hottest point of the device and the dissipating medium, divided by the power dissipated in the device.

4. OPERATIONAL NOTES

4.1 When a photoconductive device is subjected to a change of operating conditions there may be a transient change of current in excess of that due to the difference between the equilibrium illumination currents. This transient change is called overshoot.

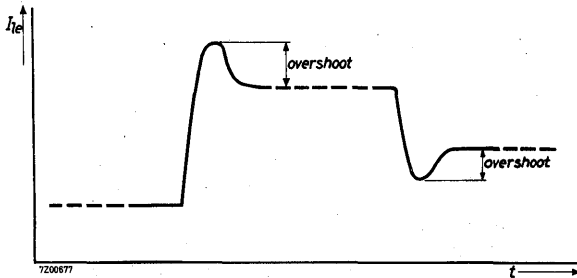

4.2 Direct sunlight irradiation should be avoided.

5. MOUNTING

5.1 If no restrictions are made on the individual published data sheets, the device may be mounted in any position.

5.2 Most of the photoconductive devices may be soldered directly into the circuit, which is indicated on the individual published data sheets. However, the heat conducted to the seal of the device should be kept to a minimum by the use of a thermal shunt. If not otherwise indicated, the device may be dip-soldered at a solder temperature of 240 °C for a maximum of 10 seconds up to a point 5 mm from the seals.

6. STORAGE

It is recommended that the devices be stored in the dark. At any rate direct sunlight irradiation should be avoided.

7. LIMITING VALUES

The limiting values of photoconductive devices are given in the absolute maximum rating system.

8. OUTLINE DIMENSIONS

The outline dimensions are given in mm.

9. MECHANICAL ROBUSTNESS

The conditions for shock and vibration given on the individual data sheets are intended only to give an indication of the mechanical quality of the device. It is not advisable to subject the device to such conditions.

7Z1014L5

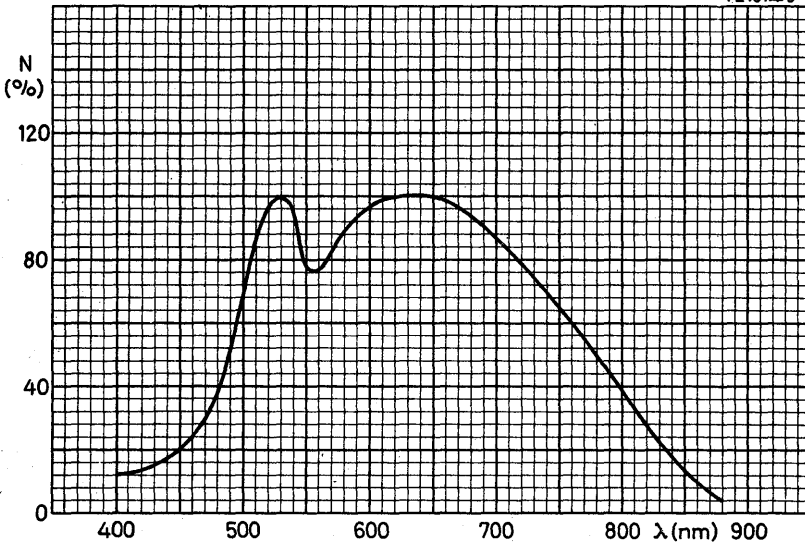

Type D response curve

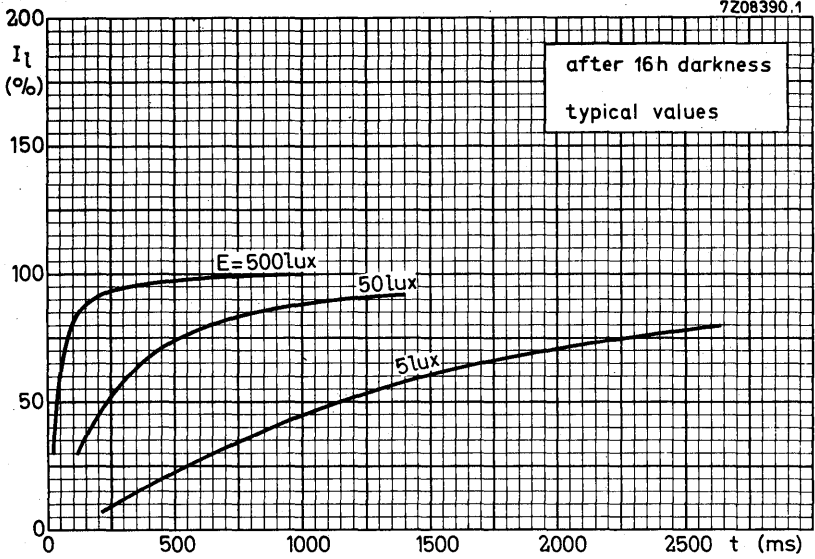

Current rise curves for cells with type D response curve

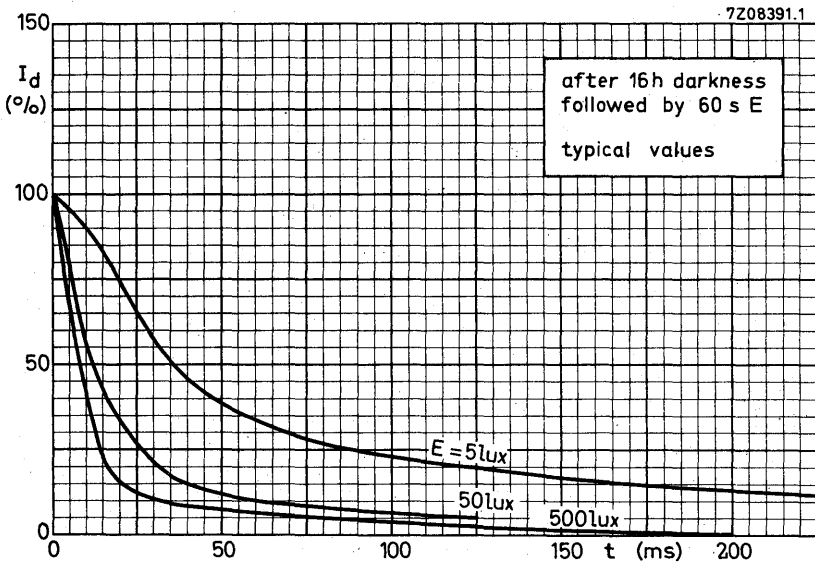

Current decay curves for cells with type D response curve

CADMIUM SULPHIDE PHOTOCONDUCTIVE CELL

Top sensitive cadmium sulphide photoconductive cell in hermetically sealed metal envelope with glass window intended for use in general control circuits such as twilight switches and flame failure circuits.
The cell is shock and vibration resistant.

QUICK REFERENCE DATA

Power dissipation at $T_{amb} = 25\text{ }^{\circ}\text{C}$	P	max.	1	W
Cell voltage, d. c. and repetitive peak	V	max.	400	V
Cell resistance at 50 lx, 2700 K colour temperature	r_{10}	typ.	3.3	$k\Omega$
Spectral response, current rise and decay curves				type D
Outline dimensions		max.	32 dia. x 7,6	mm

MECHANICAL DATA

Dimensions in mm

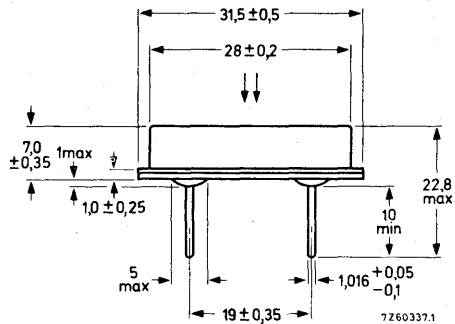
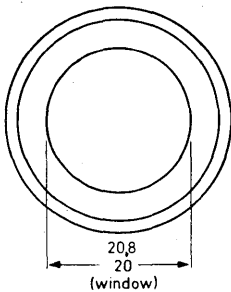

CADMIUM SULPHIDE PHOTOCONDUCTIVE CELL

Top and side sensitive cadmium sulphide photoconductive cell in hermetically sealed all-glass envelope intended for on-off applications such as flame failure circuits. The cell is shock and vibration resistant.

QUICK REFERENCE DATA

Power dissipation at $T_{amb} = 25\text{ }^{\circ}\text{C}$	P	max.	0,4	W
Cell voltage, d.c. and repetitive peak	V	max.	200	V
Cell resistance at 50 lx, 2700 K colour temperature	r_{I_0}	typ.	1200	Ω
Spectral response, current rise and decay curves			type D	
Outline dimensions		max.	15,9 dia. x 44	mm

MECHANICAL DATA

Dimensions in mm

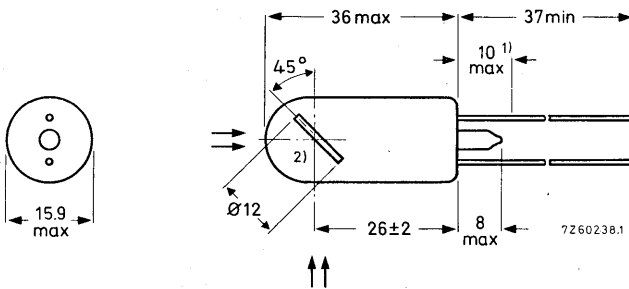

Soldering

The cell may be soldered directly into the circuit but heat conducted to the tablet should be kept to a minimum by the use of a thermal shunt. The cell may be desoldered at a solder temperature of $240\text{ }^{\circ}\text{C}$ for maximum 10 s up to a point 5 mm from the seals.

- 1) Not tinned.
- 2) Centre of sensitive area.

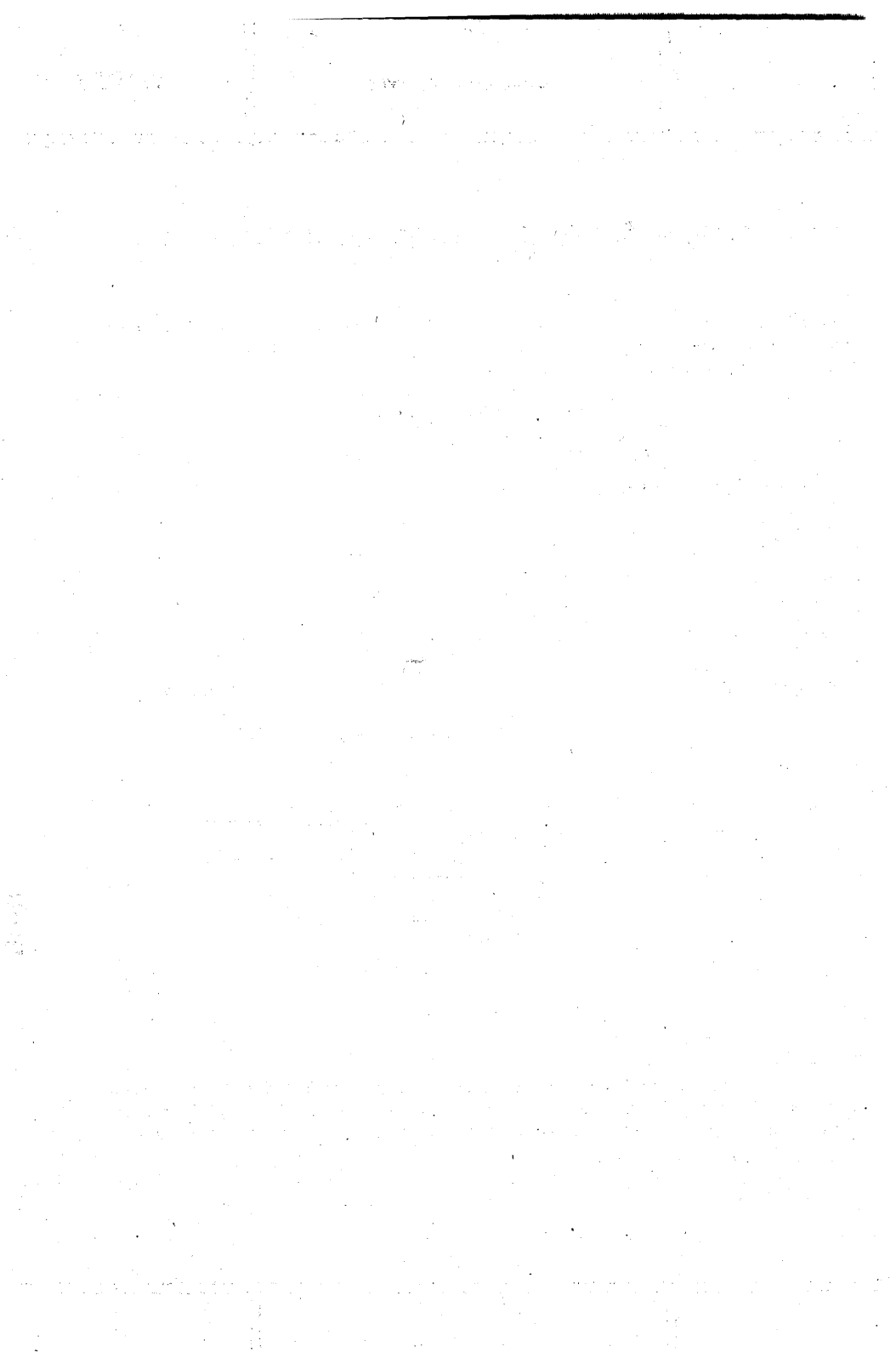

CADMIUM SULPHIDE PHOTOCONDUCTIVE CELLS

Top sensitive cadmium sulphide photoconductive cells in hermetically sealed all-glass envelope intended for on-off applications such as flame failure circuits, and for automatic brightness and contrast control in television receivers.
The cells are shock and vibration resistant.

QUICK REFERENCE DATA		
Power dissipation at $T_{amb} = 25\text{ }^{\circ}\text{C}$	P max.	70 mW
Cell voltage, d.c. and repetitive peak	V max.	350 V
Cell resistance at 50 lx, 2700 K colour temperature, ORP60 ORP66	r_{lo} typ.	60 $k\Omega$
	$r_{lo} <$	55 $k\Omega$
Spectral response, current rise and decay curves		type D
Outline dimensions		max. 6 dia. x 15,5 mm

MECHANICAL DATA

Dimensions in mm

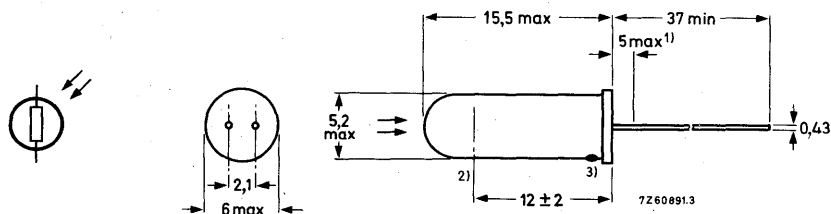

Soldering

The cell may be soldered directly into the circuit but heat conducted to the tablet should be kept to a minimum by the use of a thermal shunt. The cell may be dip-soldered at a solder temperature of $240\text{ }^{\circ}\text{C}$ for maximum 10 s up to a point 5 mm from the seals.

- 1) Not tinned.
- 2) Sensitive surface.
- 3) Blue dot on ORP66.

ELECTRICAL DATA

General

The electrical properties of CdS cells are dependent on many factors such as illumination, colour temperature of the light source, voltage, current, temperature, total time of operation in the circuit and time of operation during the last 24 hours prior to the measurement. The following basic characteristics are therefore only check points of the electrical properties of these devices measured with defined values of the various conditions and at delivery.

Basic characteristics at $T_{amb} = 25^{\circ}C$, illumination with colour temperature of 2700 K and at delivery

		ORP60	ORP66
Initial dark resistance			
measured at 300 V d. c. applied via 1 M Ω , 20 s after switching off the illumination	$r_{do} >$	200	200 M Ω ¹⁾
Initial illumination resistance			
measured at 30 V d. c., illumination = 50 lx, after 16 hrs in darkness ²⁾	$r_{lo} >$ typ. <	37,5 60 150	- k Ω - k Ω 55 k Ω
Equilibrium illumination resistance			
measured at 30 V d. c., illumination = 50 lx, after 15 min under the measuring conditions	$r_{le} >$ typ. <	37,5 75 190	- k Ω - k Ω 90 k Ω
Negative temperature response of illumination resistance	typ. <	0,2 0,5	%/ $^{\circ}C$ %/ $^{\circ}C$
Voltage response	$\frac{r \text{ at } 0,5 \text{ V d. c.}}{r \text{ at } 30 \text{ V d. c.}}$	α typ.	1,5

¹⁾ The spread of the dark resistance is large and values higher than 1000 M Ω are possible for the initial dark resistance.

²⁾ After 16 hours in darkness changes in the CdS material are still occurring but have only insignificant effect on the illumination resistance.

**ORP60
ORP66**

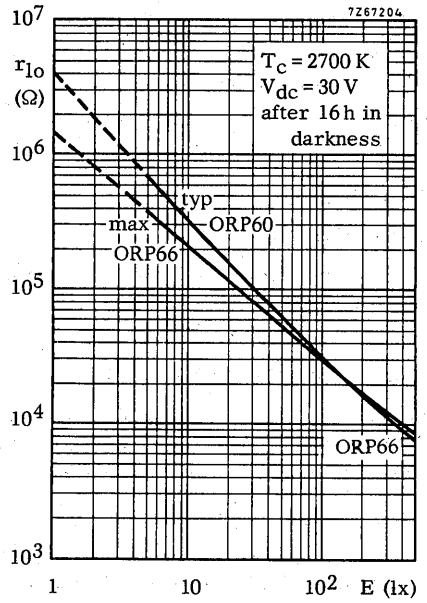
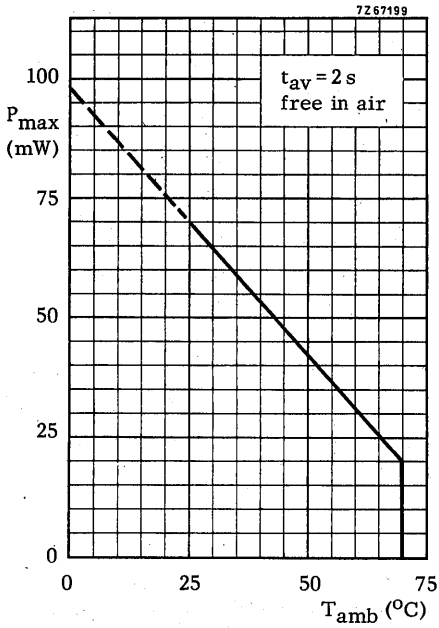

CADMIUM SULPHIDE PHOTOCONDUCTIVE CELLS

Side sensitive cadmium sulphide photoconductive cells in hermetically sealed all-glass envelope intended for on-off applications such as flame failure circuits, and for automatic brightness and contrast control in television receivers. The cells are shock and vibration resistant.

QUICK REFERENCE DATA			
		ORP61	ORP62
Power dissipation at $T_{amb} = 25\text{ }^{\circ}\text{C}$	P	max. 70	100 mW
Cell voltage, d. c. and repetitive peak	V	max. 350	350 V
Cell resistance at 50 lx, 2700 K colour temperature	r_{10}	typ. 60	45 k Ω
Spectral response, current rise and decay curves			type D
Outline dimensions		max. 6 dia. x 15,5 mm	

MECHANICAL DATA

Dimensions in mm

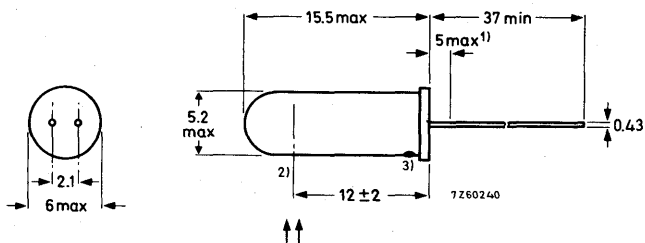

Soldering

The cell may be soldered directly into the circuit but heat conducted to the tablet should be kept to a minimum by the use of a thermal shunt. The cell may be desoldered at a solder temperature of 240 °C for maximum 10 s up to a point 5 mm from the seals.

- 1) Not tinned
- 2) Centre of sensitive area
- 3) ORP61 brown dot; ORP62 red dot.

ELECTRICAL DATA

General

The electrical properties of CdS cells are dependent on many factors such as illumination, colour temperature of the light source, voltage, current, temperature, total time of operation in the circuit and time of operation during the last 24 hours prior to the measurement. The following basic characteristics are therefore only check points of the electrical properties of these devices measured with defined values of the various conditions and at delivery.

Basic characteristics at $T_{amb} = 25\text{ }^{\circ}\text{C}$, illumination with colour temperature of 2700 K and at delivery.

		ORP61	ORP62	
Initial dark resistance				
measured at 300 V d.c. applied via 1 M Ω , 20 s after switching off the illumination	$r_{do} >$	200	150	M Ω 1)
Initial illumination resistance	$>$	37,5	30	k Ω
measured at 30 V d.c., illumination = 50 lx, after 16 hrs in darkness 2)	r_{lo} typ. $<$	60 150	45 100	k Ω k Ω
Equilibrium illumination resistance	$>$	37,5	30	k Ω
measured at 30 V d.c., illumination = 50 lx, after 15 min under the measuring conditions	r_{le} typ. $<$	75 190	60 170	k Ω k Ω
Negative temperature response of illumination resistance	typ. $<$	0,2 0,5	0,2 0,5	%/ $^{\circ}\text{C}$ %/ $^{\circ}\text{C}$
Voltage response	$\frac{r \text{ at } 0,5 \text{ V d.c.}}{r \text{ at } 30 \text{ V d.c.}}$	α typ.	1,5	1,4

- 1) The spread of the dark resistance is large and values higher than 1000 M Ω are possible for the initial dark resistance.
- 2) After 16 hours in darkness changes in the CdS material are still occurring but have only insignificant effect on the illumination resistance.

RATINGS Limiting values in accordance with the Absolute Maximum System (IEC 134)

Cell voltage, d. c. and repetitive peak	V	max.	350 V
Cell voltage, pulse, $t_p \leq 5$ ms; $P_{RR} \leq$ once per minute - ORP61	V_M	max.	500 V
ORP62	V_M	max.	1000 V
Power dissipation ($t_{av} = 2$ s) see graph P_{max}			
Power dissipation, pulse	P_M	max.	$5 \times P_{max}$
Illumination	E	max.	50 000 lx
Temperature CdS tablet, operating	T_{tablet}	max.	85 °C
Ambient temperature, storage and operation	T_{amb}	min.	-40 °C
storage	T_{stg}	max.	50 °C 1)
operating	T_{amb}	max.	70 °C

DESIGN CONSIDERATIONS

Apparatus with CdS cells should be designed so that under rated load, during life, changes in illumination resistance - for ORP61 from -50 % to +100 % (typ. +50 %) and for ORP62 from -30 % to +70 % (typ. +40 %) - do not impair the circuit performance. Direct irradiation by sunlight should be avoided.

MECHANICAL ROBUSTNESS

An indication for the ruggedness of the device is the following:

Samples taken from normal production are submitted to shock and vibration tests mentioned below. More than 95 % of the devices pass these tests without perceptible damage.

Shock

25 g_{peak} , 10 000 shocks in one of the three positions of the cell.

Vibration

2,5 g_{peak} , 50 Hz, during 32 hours in each of the three positions of the cell.

1) Operation of the cell counteracts the deteriorating effect of long periods at high temperature. The maximum operating temperature is therefore higher than the maximum storage temperature.

**ORP61
ORP62**

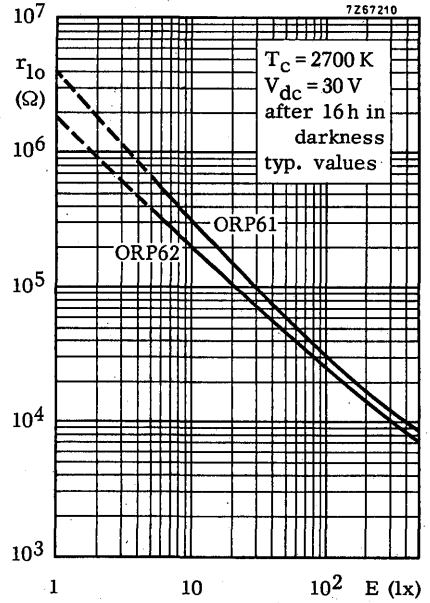
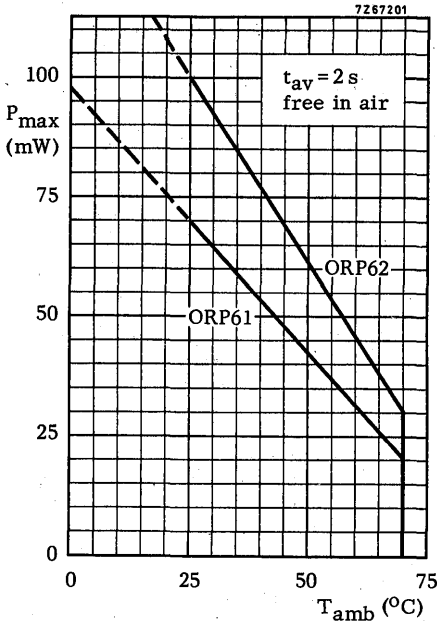

CADMIUM SULPHIDE PHOTOCONDUCTIVE CELL

See data ORP60



CADMIUM SULPHIDE PHOTOCONDUCTIVE CELLS

Top and side sensitive cadmium sulphide photoconductive cells in hermetically sealed all-glass envelope intended for on-off applications such as flame failure circuits, and for automatic brightness and contrast control in television receivers.
The cells are shock and vibration resistant.

QUICK REFERENCE DATA			
Power dissipation at $T_{amb} = 25\text{ }^{\circ}\text{C}$	P	max.	100 mW
Cell voltage, d. c. and repetitive peak	V	max.	350 V
Cell resistance at 50 lx, 2700 K colour temperature, ORP68	r_{10}	typ.	64 $k\Omega$
	ORP69	r_{10} typ.	30 $k\Omega$
Spectral response, current rise and decay curves			type D
Outline dimensions	max.		6 dia. x 15,5 mm

MECHANICAL DATA

Dimensions in mm

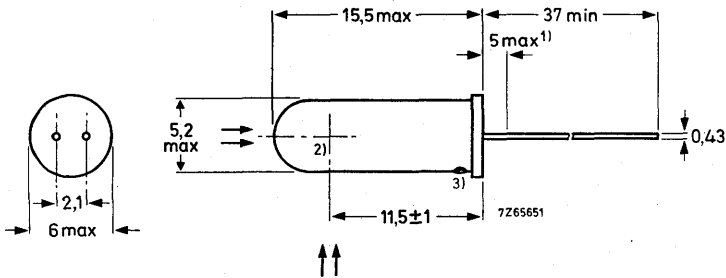

Soldering

The cell may be soldered directly into the circuit but heat conducted to the tablet should be kept to a minimum by the use of a thermal shunt. The cell may be desoldered at a solder temperature of $240\text{ }^{\circ}\text{C}$ for maximum 10 s up to a point 5 mm from the seals.

- 1) Not tinned.
- 2) Centre of sensitive area.
- 3) ORP68: gray dot; ORP69: white dot.



ELECTRICAL DATA

General

The electrical properties of CdS cells are dependent on many factors such as illumination, colour temperature of the light source, voltage, current, temperature, total time of operation in the circuit and the time of operation during the last 24 hours prior to the measurement. The following basic characteristics are therefore only check points of the electrical properties of these devices measured with defined values of the various conditions and at delivery.

Basic characteristics at $T_{amb} = 25\text{ }^{\circ}\text{C}$, illumination with colour temperature of 2700 K and at delivery

		ORP68	ORP69	
Initial dark resistance				
measured with 300 V d.c. applied via 1 M Ω , 20 s after switching off the illumination	r_{do} >	150	100	M Ω 1)
Initial illumination resistance	>	30	20	k Ω
measured at 30 V d.c., illumination = 50 lx, after 16 h in darkness 2) 3)	r_{lo} typ. <	46 100	30 60	k Ω k Ω
Equilibrium illumination resistance	>	30	27	k Ω
measured at 30 V d.c., illumination = 50 lx, after 15 min under the measuring conditions	r_{le} typ. <	60 170	46 115	k Ω k Ω
Negative temperature response of illumination resistance	typ. <	0,2 0,5		%/ $^{\circ}\text{C}$ %/ $^{\circ}\text{C}$
Voltage response $\frac{r}{r}$ at 0,5 V d.c. $\frac{r}{r}$ at 30 V d.c.	typ.	1,4		

- 1) The spread of the dark resistance is large and values higher than 1000 M Ω are possible for the initial dark resistance.
- 2) After 16 hours in darkness changes in the CdS material are still occurring but have only insignificant effect on the illumination resistance.
- 3) Measured at top sensitivity.

RATINGS Limiting values in accordance with the Absolute Maximum System (IEC 134)

Cell voltage, d. c. and repetitive peak	V	max.	350	V
Cell voltage, pulse, $t_p \leq 5$ ms, $P_{TR} \leq$ once per minute - ORP68 ORP69	V_M	max.	1000	V
	V_M	max.	700	V
Power dissipation ($t_{av} = 2$ s) see graph P_{max}				
Power dissipation, pulse	P_M	max.	$5 \times P_{max}$	
Illumination	E	max.	50 000	lx
Temperature of CdS tablet, operating	T_{tablet}	max.	+85	°C
Ambient temperature, storage and operating storage operating	T_{amb}	min.	-40	°C
	T_{stg}	max.	+50	°C 1)
	T_{amb}	max.	+70	°C

DESIGN CONSIDERATIONS

Apparatus with CdS cells should be so designed that changes in illumination resistance of the cells during life under rated load from -30 % to +70 % (typ. +40 %) do not impair the circuit performance. Direct irradiation by sunlight should be avoided.

MECHANICAL ROBUSTNESS

An indication of the ruggedness of the device is the following:

Samples taken from normal production are submitted to shock and vibration tests mentioned below. More than 95 % of the devices pass these tests without perceptible damage.

Shock

25 g_{peak} , 10 000 shocks in one of the three positions of the cell

Vibration

2,5 g_{peak} , 50 Hz, during 32 hours in each of the three positions of the cell.

1) Operation of the cell counteracts the deteriorating effect of long periods at high temperature. The maximum operating temperature is therefore higher than the maximum storage temperature.

**ORP68
ORP69**

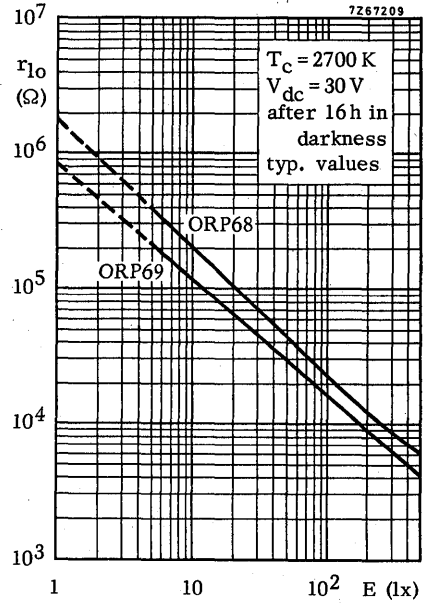
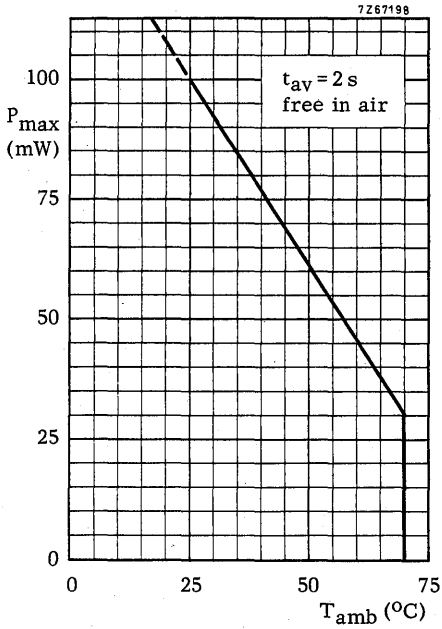

CADMIUM SULPHIDE PHOTOCONDUCTIVE DEVICE

Cadmium sulphide photoconductive device with side sensitivity in plastic encapsulation. The device consists of two cells connected in series and is intended for general applications.

QUICK REFERENCE DATA

Power dissipation at $T_{amb} \leq 25 \text{ }^\circ\text{C}$	P	100	mW
Voltage, d. c. and repetitive peak	V	max. 50	V
Resistance at 50 lux, $T_c = 2700 \text{ }^\circ\text{K}$	r_{l_0}	600	Ω
Wavelengths at 50% sensitivity	λ	500 and 675	nm
Outline dimensions	max.	5,3 x 5,3 x 1,4	mm

MECHANICAL DATA

Dimensions in mm

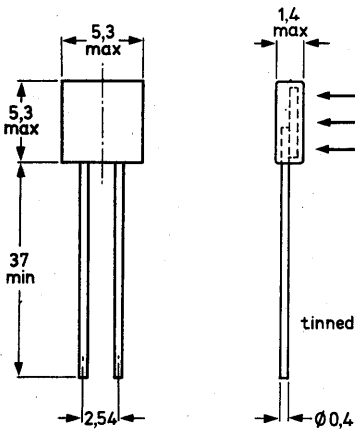

Soldering

The device may be soldered direct into the circuit but heat conducted to the tablet should be kept to a minimum by the use of a thermal shunt.

It may be dip-soldered at a solder temperature of 270 $^\circ\text{C}$ for a maximum of 2 s up to a point 6 mm from the envelope.

RATINGS Limiting values in accordance with the Absolute Maximum System (IEC134)

Cell voltage, d.c. and repetitive peak	V	max.	50	V
Cell voltage, $P_{rr} \leq$ once per minute, $t_p \leq 5$ ms	V_M	max.	100	V
Power dissipation, $t_{av} = 0,5$ s, $T_{amb} \leq 25$ °C	P	max.	100	mW
Cell current, d.c. and repetitive peak	I	max.	25	mA
Ambient temperature, storage and operating storage	T_{amb}	min.	-40	°C
	T_{stg}	max.	+50	°C
Temperature of CdS tablet	T_{tablet}	max.	+70	°C

THERMAL RESISTANCE

Thermal resistance from CdS tablet to ambient	$R_{th\ t-a}$	=	0,45	°C/mW
---	---------------	---	------	-------

CHARACTERISTICS

Initial dark resistance, measured with 50 V d.c. applied via 1 M Ω , 20 s after switching off the illumination	r_{do}	>	200	k Ω
Initial illumination resistance measured at 1 V d.c., illumination 50 lx, $T_c = 2700$ K	r_{10}	typ.	0,6 0,35-1,4	k Ω k Ω
Initial drift	D_o	typ.	0	%
F_{4700} ($= \frac{r_1 \text{ at } 4700 \text{ K}}{r_1 \text{ at } 2856 \text{ K}}$ at constant illumination and using a Davis-Gibson filter)		typ.	1,2	

OPERATING NOTES

- The device consists of two photoconductive cells connected in series. The resistance of the device is mainly governed by the resistance of that cell receiving the lower luminous flux.
If it is required for any application that the device is partly shaded, the shadow line should be perpendicular to the axis of the device.
- For optimum heat dissipation use the shortest permissible lead length.

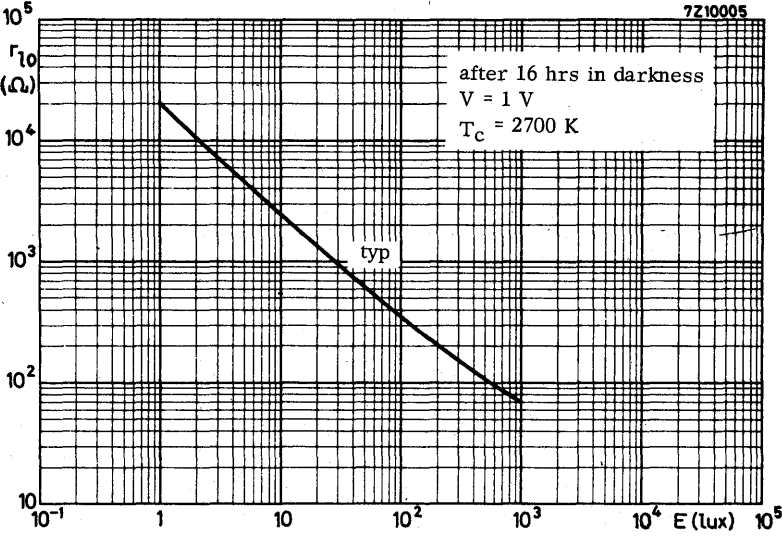

7Z10004

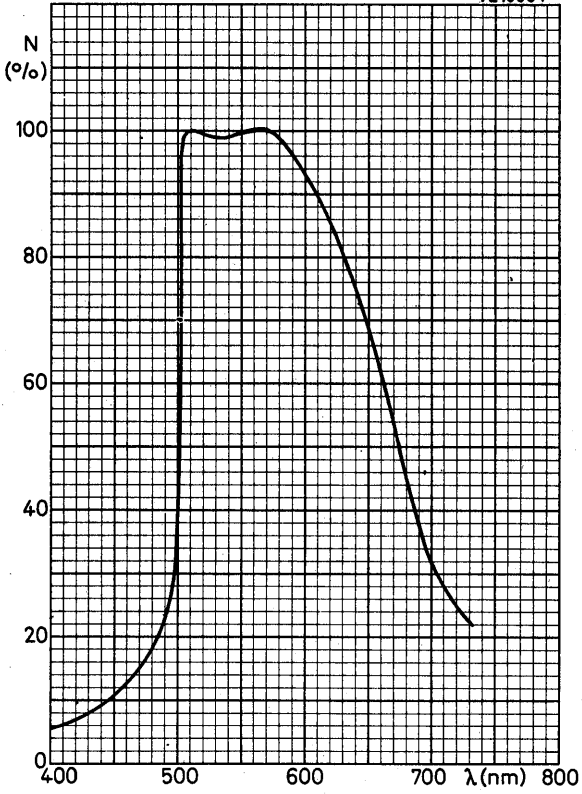

CADMIUM SULPHIDE PHOTOCONDUCTIVE DEVICE

Cadmium sulphide photoconductive cell with side sensitivity in a plastic encapsulation. The device consists of two cells in series and is intended for use in cameras, exposure meters, light control equipment and for general industrial use.

QUICK REFERENCE DATA

Power dissipation	P	max.	50 mW
Cell voltage, d.c. and repetitive peak	V	max.	50 V
Cell resistance at 10 lux, 2700 °K	r_{I0}		3 to 6 k Ω
Outline dimensions			5 mm x 5 mm x 1 mm

MECHANICAL DATA

Dimensions in mm

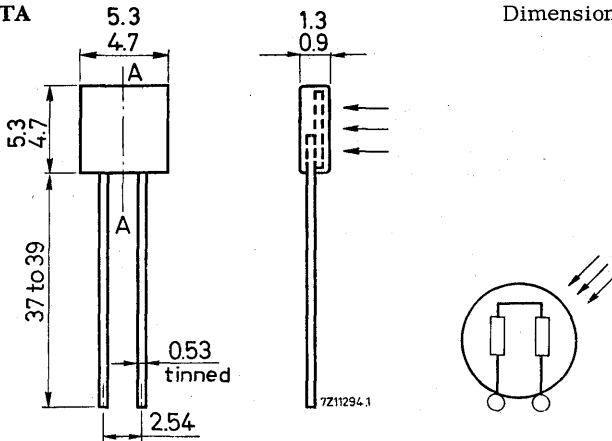

Soldering

The device may be soldered direct into the circuit but heat conducted to the seals should be kept at a minimum by the use of a thermal shunt. Dip soldering at a solder temperature of 270 °C may be employed for a maximum of 2 s up to a point 6 mm from the seals.

ELECTRICAL DATA

Basic characteristics at $T_{amb} = 25\text{ }^{\circ}\text{C}$, illumination with 2700 K c. t.

Pre-conditioning 1 h illumination with 300 lx (fluorescent light)

	symbol	min.	typical	max.	unit
Initial dark resistance measured with 50 V _{d.c.} applied via 1 M Ω , 20 s after stopping the illumination of 10 lx	r_{d0}	0.6			M Ω
Initial illumination resistance measured at $V = 1\text{ V}_{d.c.}$, illumination 10 lx	r_{l0}	2.4		6.0	k Ω
Illumination response 1) measured at 1 V _{d.c.} between 0.1 lx and 10 lx	$\gamma_{0.1 - 10}$	0.94		1.12	
Negative temperature response of illumination resistance between $-10\text{ }^{\circ}\text{C}$ and $+40\text{ }^{\circ}\text{C}$ at 1 lx, $V = 1\text{ V}$	$r_l/\Delta T$			0.5	%/ $^{\circ}\text{C}$
Pre-conditioning factor 2)		0.9		1.1	
Actinism <u>Illumination at 2700 K</u> Illumination at 4700 K (referred to the same cell current)		0.9		1.1	

1) $\gamma = \frac{\log r_1 - \log r_2}{\log E_2 - \log E_1}$ where $E_1 = 0.1\text{ lx}$ and $E_2 = 10\text{ lx}$

2) Pre-conditioning factor = $\frac{\text{Cell current at 1 lx, after 3 days in darkness}}{\text{Cell current at 1 lx, after 1 h pre-conditioning at 300 lx (fluorescent light)}}$
measured when a stable current is reached

LIMITING VALUES (Absolute max. rating system)

Cell voltage, d.c. and repetitive peak	V	max.	50 V
Power dissipation	P	max.	50 mW
Cell current, d.c. and repetitive peak	I	max.	20 mA
Operating ambient temperature	T _{amb}	-40 to +70	°C
Storage temperature	T _{stg}	-40 to +70	°C

OPERATING NOTE

The device consists of two photoconductive cells connected in series. The resistance of the device is mainly governed by the resistance of that cell receiving the lowest luminous flux. If it is essential for the application that the device is partly shaded off, the shadow line should be perpendicular to the axis A-A of the device.

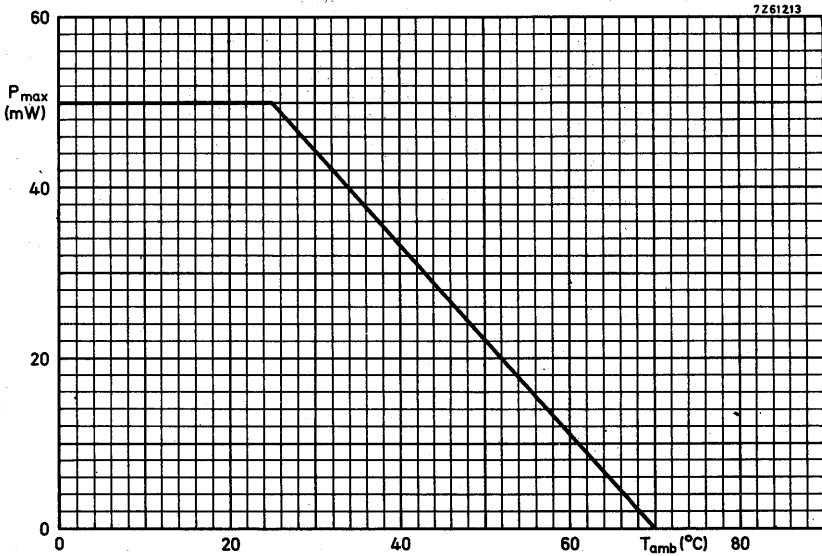

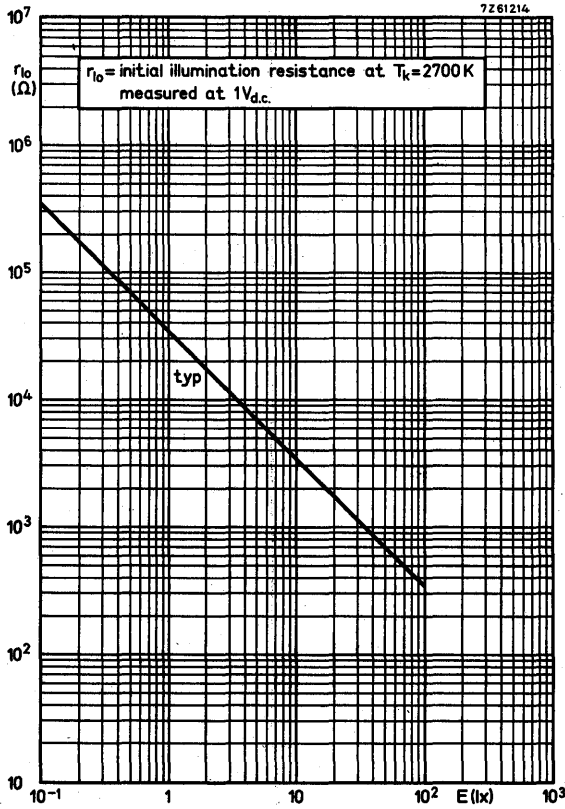

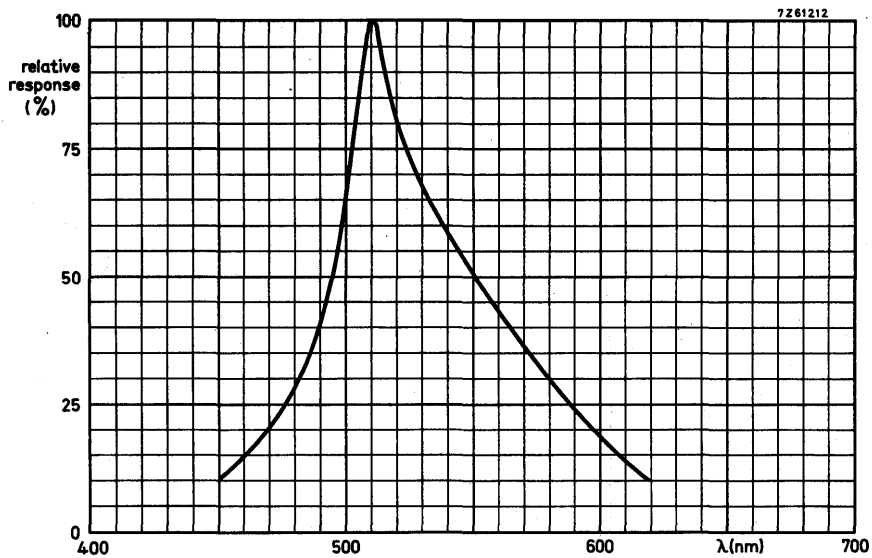



CADMIUM SULPHIDE PHOTOCONDUCTIVE CELL

Side sensitive cadmium sulphide photoconductive cell protected by a lacquer coating. The device withstands the steady state damp heat test of IEC Publication 68-2-3 (test Ca: severity 56 days).

QUICK REFERENCE DATA

Power dissipation at $T_{amb} = 25\text{ }^{\circ}\text{C}$	P	max.	0,30	W
Cell voltage, d.c. and repetitive peak	V	max.	100	V
Cell resistance at 50 lx, 2700 K colour temperature	r_{10}		950	Ω
Spectral response, current rise and decay curves		type D		
Outline dimensions		max.	11,5 x 8,8 x 1,5	mm

MECHANICAL DATA

Dimensions in mm

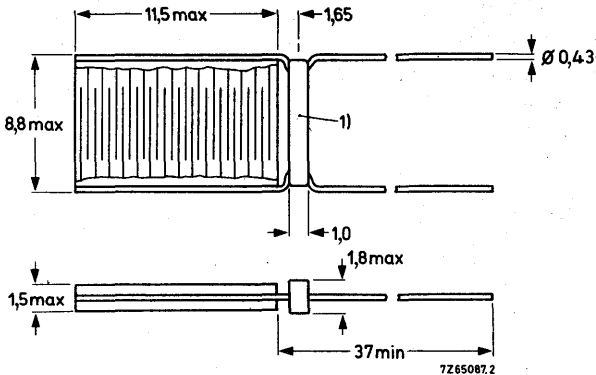

Soldering

The cell may be soldered directly into the circuit but heat conducted to the tablet should be kept to a minimum by the use of a thermal shunt. The cell may be desoldered at a solder temperature of $240\text{ }^{\circ}\text{C}$ for maximum 10 s up to a point 5 mm from the stress relief band.

Mounting

The cell is not insulated electrically and should be mounted accordingly.

Notice

If the cell is to be encapsulated, request manufacturer's instructions.

1) Stress relief band.

ELECTRICAL DATA

General

The electrical properties of CdS cells are dependent on many factors such as illumination, colour temperature of the light source, voltage, current, temperature, total time of operation in the circuit and time of operation during the last 24 hours prior to the measurement. The following basic characteristics are therefore only check points of the electrical properties of these devices measured with defined values of the various conditions and at delivery.

Basic characteristics at $T_{amb} = 25\text{ }^{\circ}\text{C}$, illumination with colour temperature of 2700 K and at delivery

Initial dark resistance measured with 100 V d. c. applied via 1 M Ω , 20 s after switching off the illumination	r_{do}	>	6	M Ω 1)
Equilibrium dark resistance measured with 100 V d. c. applied via 1 M Ω , 30 minutes after switching off the illumination	r_{de}	>	50	M Ω 1)
Initial illumination resistance measured at 10 V d. c., illumination = 50 lx, after 16 hrs in darkness 2)	r_{lo}		560 to 2800 typ. 950	Ω Ω
Equilibrium illumination resistance measured at 10 V d. c., illumination = 50 lx, after 15 min under the measuring conditions	r_{le}		560 to 3800 typ. 1200	Ω Ω
Negative temperature response of illumination resistance		<	0,5 typ. 0,2	%/ $^{\circ}\text{C}$ %/ $^{\circ}\text{C}$
Voltage response $\frac{r \text{ at } 0,5 \text{ V d. c.}}{r \text{ at } 10 \text{ V d. c.}}$	α	typ.	1,05	

- 1) The spread of the dark resistance is large and values higher than 100 M Ω and 1000 M Ω are possible for the initial dark resistance and the equilibrium dark resistance respectively.
- 2) After 16 hours in darkness changes in the CdS material are still occurring but have only insignificant effect on the illumination resistance.

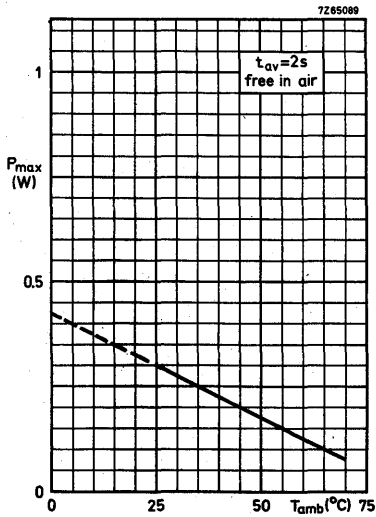
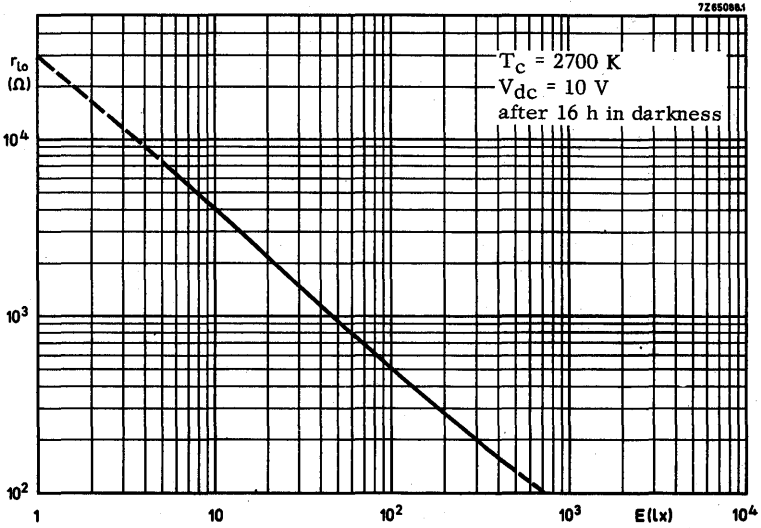

CADMIUM SULPHIDE PHOTOCONDUCTIVE CELL

Side sensitive cadmium sulphide photoconductive cell protected by a lacquer coating. The device withstands the steady state damp heat test of IEC publication 68-2-3 (test Ca: severity 56 days).

QUICK REFERENCE DATA			
Power dissipation at $T_{amb} = 25\text{ }^{\circ}\text{C}$	P	max.	0,75 W
Cell voltage, d. c. and repetitive peak	V	max.	400 V
Cell resistance at 50 lx, 2700 K colour temperature	r_{10}	typ.	1150 Ω
Spectral response, current rise and decay curves		type D	
Outline dimensions		max.	29,5 x 12,6 x 1,5 mm

MECHANICAL DATA

Dimensions in mm

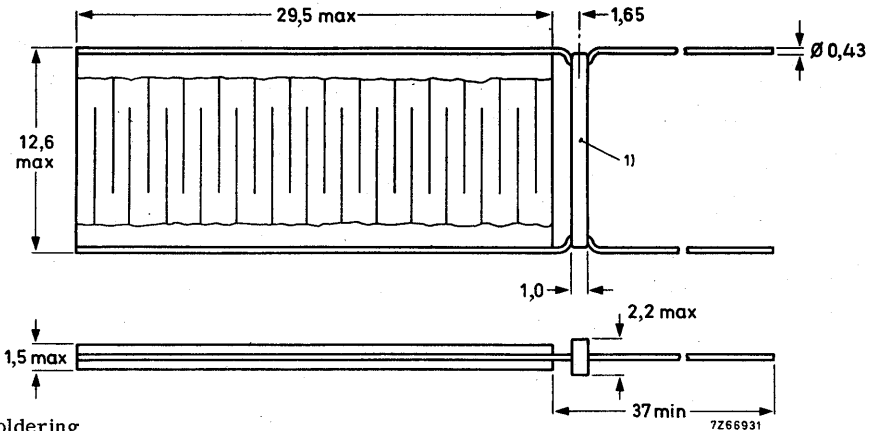

Soldering

The cell may be soldered directly into the circuit but heat conducted to the tablet should be kept to a minimum by the use of a thermal shunt. The cell may be desoldered at a solder temperature of 240 $^{\circ}\text{C}$ for maximum 10 s up to a point 5 mm from the stress relief band.

Mounting

The cell is not insulated electrically and should be mounted accordingly.

Notice

If the cell is to be encapsulated, request manufacturer's instructions.

- 1) Stress relief band.

ELECTRICAL DATA

General

The electrical properties of CdS cells are dependent on many factors such as illumination, colour temperature of the light source, voltage, current, temperature, total time of operation in the circuit and time of operation during the last 24 hours prior to the measurement. The following basic characteristics are therefore only check points of the electrical properties of these devices measured with defined values of the various conditions and at delivery.

Basic characteristics at $T_{amb} = 25\text{ }^{\circ}\text{C}$, illumination with colour temperature of 2700 K and at delivery

Initial dark resistance measured with 400 V d.c. applied via 1 M Ω , 20 s after switching off the illumination	r_{do}	>	9	M Ω 1)
Equilibrium dark resistance measured with 400 V d.c. applied via 1 M Ω , 30 minutes after switching off the illumination	r_{de}	>	200	M Ω 1)
Initial illumination resistance measured at 10 V d.c., illumination = 50 lx, after 16 hrs in darkness 2)	r_{lo}		700 to 3300 typ. 1150	Ω Ω
Equilibrium illumination resistance measured at 10 V d.c., illumination = 50 lx, after 15 min under the measuring conditions	r_{le}		700 to 4100 typ. 1450	Ω Ω
Negative temperature response of illumination resistance		typ. <	0,2 0,5	%/ $^{\circ}\text{C}$ %/ $^{\circ}\text{C}$
Voltage response $\frac{r \text{ at } 0,5 \text{ V d.c.}}{r \text{ at } 10 \text{ V d.c.}}$	α	typ.	1,05	

1) The spread of the dark resistance is large and values higher than 100 M Ω and 1000 M Ω are possible for the initial dark resistance and the equilibrium dark resistance respectively.

2) After 16 hours in darkness changes in the CdS material are still occurring but have only insignificant effect on the illumination resistance.

7268930

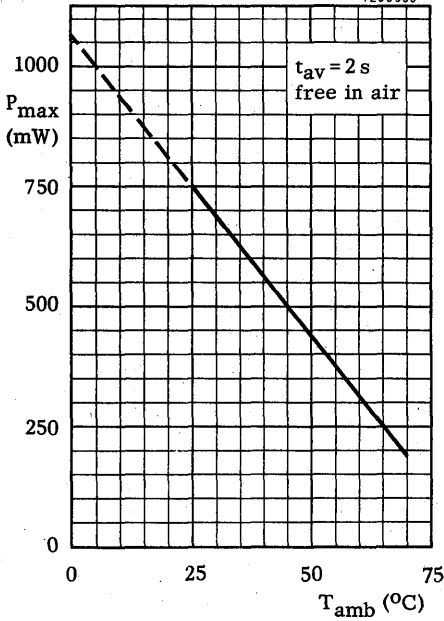

7268929

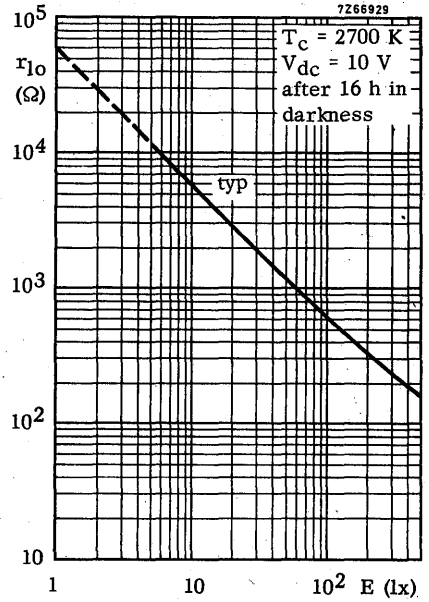

CADMIUM SULPHIDE PHOTOCONDUCTIVE CELL

Side sensitive cadmium sulphide photoconductive cell protected by a lacquer coating. The device withstands the steady state damp heat test of IEC publication 68-2-3 (test Ca: severity 56 days).

QUICK REFERENCE DATA

Power dissipation at $T_{amb} = 25\text{ }^{\circ}\text{C}$	P	max.	0,500	W
Cell voltage, d.c. and repetitive peak	V	max.	200	V
Cell resistance at 50 lx, 2700 K colour temperature	r_{l0}	typ.	1150	Ω
Spectral response, current rise and decay curves		type D		
Outline dimensions		max.	15 x 12,6 x 1,5	mm

MECHANICAL DATA

Dimensions in mm

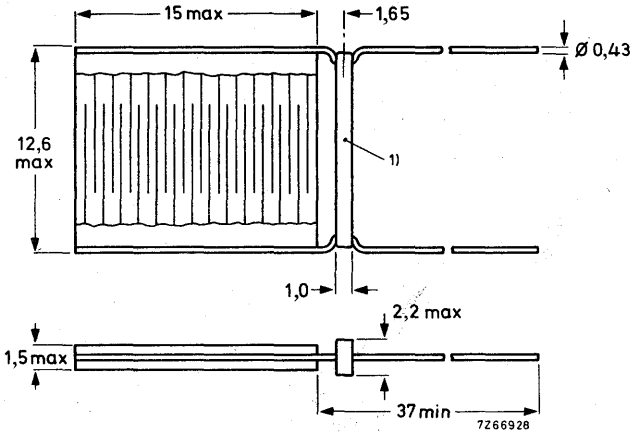

Soldering

The cell may be soldered directly into the circuit but heat conducted to the tablet should be kept to a minimum by the use of a thermal shunt. The cell may be desoldered at a solder temperature of 240 °C for maximum 10 s up to a point 5 mm from the stress relief band.

Mounting

The cell is not insulated electrically and should be mounted accordingly.

Notice

If the cell is to be encapsulated, request manufacturer's instructions.

1) Stress relief band.

ELECTRICAL DATA

General

The electrical properties of CdS cells are dependent on many factors such as illumination, colour temperature of the light source, voltage, current, temperature, total time of operation in the circuit and time of operation during the last 24 hours prior to the measurement. The following basic characteristics are therefore only check points of the electrical properties of these devices measured with defined values of the various conditions and at delivery.

Basic characteristics at $T_{amb} = 25\text{ }^{\circ}\text{C}$, illumination with colour temperature of 2700 K and at delivery

Initial dark resistance measured with 200 V d.c. applied via 1 M Ω , 20 s after switching off the illumination	r_{do}	>	9	M Ω 1)
Equilibrium dark resistance measured with 200 V d.c. applied via 1 M Ω , 30 minutes after switching off the illumination	r_{de}	>	100	M Ω 1)
Initial illumination resistance measured at 10 V d.c., illumination = 50 lx, after 16 hrs in darkness 2)	r_{lo}		700 to 3300 typ. 1150	Ω Ω
Equilibrium illumination resistance measured at 10 V d.c., illumination = 50 lx, after 15 min under the measuring conditions	r_{le}		700 to 4100 typ. 1450	Ω Ω
Negative temperature response of illumination resistance		<	0,5 typ. 0,2	%/ $^{\circ}\text{C}$ %/ $^{\circ}\text{C}$
Voltage response	$\frac{r \text{ at } 0,5 \text{ V d.c.}}{r \text{ at } 10 \text{ V d.c.}}$	α	typ. 1,05	

- 1) The spread of the dark resistance is large and values higher than 100 M Ω and 1000 M Ω are possible for the initial dark resistance and the equilibrium dark resistance respectively.
- 2) After 16 hours in darkness changes in the CdS material are still occurring but have only insignificant effect on the illumination resistance.

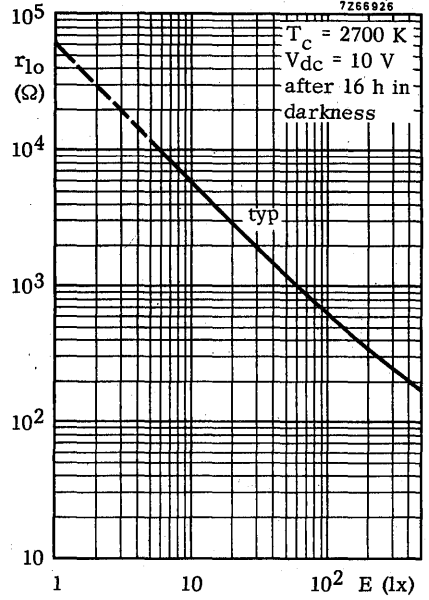
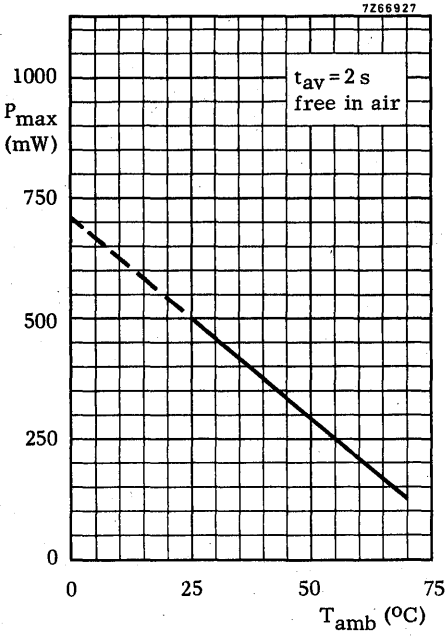





GENERAL

PHOTOSENSITIVE DIODES AND TRANSISTORS

LIGHT EMITTING DIODES

PHOTOCOUPPLERS

INFRARED SENSITIVE DEVICES

PHOTOCONDUCTIVE DEVICES



Argentina: FAPESA I y C., Av. Crovara 2550, Tablada, Prov. de BUENOS AIRES, Tel. 652-7438/7478.

Austria: PHILIPS INDUSTRIES HOLDINGS LTD., Elcoma Division, 67 Mars Road, LANE COVE, 2066, N.S.W., Tel. 427 08 88.

Austria: ÖSTERREICHISCHE PHILIPS BAUELEMENTE Industrie G.m.b.H., Triester Str. 64, A-1101 WIEN, Tel. 62 91 11.

Belgium: M.B.L.E., 80, rue des Deux Gares, B-1070 BRUXELLES, Tel 523 00 00.

Brazil: IBRAPE, Caixa Postal 7383, Av. Paulista 2073-S/Loja, SAO PAULO, SP, Tel. 284-4511.

Canada: PHILIPS ELECTRONICS LTD., Electron Devices Div., 601 Milner Ave., SCARBOROUGH, Ontario, M1B 1M8, Tel. 292-5161.

Chile: PHILIPS CHILENA S.A., Av. Santa Maria 0760, SANTIAGO, Tel. 39-40 01.

Colombia: SADAPE S.A., P.O. Box 9805, Calle 13, No. 51 + 39, BOGOTA D.E. 1., Tel. 600 600.

Denmark: MINIWATT A/S, Emdrupvej 115A, DK-2400 KØBENHAVN NV., Tel. (01) 69 16 22.

Finland: OY PHILIPS AB, Elcoma Division, Kaivokatu 8, SF-00100 HELSINKI 10, Tel. 1 72 71.

France: R.T.C. LA RADIOTECHNIQUE-COMPELEC, 130 Avenue Ledru Rollin, F-75540 PARIS 11, Tel. 355-44-99.

Germany: VALVO, UB Bauelemente der Philips G.m.b.H., Valvo Haus, Burchardstrasse 19, D-2 HAMBURG 1, Tel. (040) 3296-1.

Greece: PHILIPS S.A. HELLENIQUE, Elcoma Division, 52, Av. Syngrou, ATHENS, Tel. 915 311.

Hong Kong: PHILIPS HONG KONG LTD., Comp. Dept., Philips Ind. Bldg., Kung Yip St., K.C.T.L. 289, KWAI CHUNG, N.T. Tel. 12-24 51 21.

India: PHILIPS INDIA LTD., Elcoma Div., Band Box House, 254-D, Dr. Annie Besant Rd., Prabhadevi, BOMBAY-25-DD, Tel. 457 311-5.

Indonesia: P.T. PHILIPS-RALIN ELECTRONICS, Elcoma Division, 'Timah' Building, Jl. Jen. Gatot Subroto, JAKARTA, Tel. 44 163.

Ireland: PHILIPS ELECTRICAL (IRELAND) LTD., Newstead, Clonskeagh, DUBLIN 14, Tel. 69 33 55.

Italy: PHILIPS S.p.A., Sezione Elcoma, Piazza IV Novembre 3, I-20124 MILANO, Tel. 2-6994.

Japan: NIHON PHILIPS CORP., Shuwa Shinagawa Bldg., 26-33 Takanawa 3-chome, Minato-ku, TOKYO (108), Tel. 448-5611.
(IC Products) SIGNETICS JAPAN, LTD., TOKYO, Tel. (03) 230-1521.

Korea: PHILIPS ELECTRONICS (KOREA) LTD., Elcoma Division, Philips House, 260-199 Itaewon-dong, Yongsan-ku, SEOUL, Tel. 794-4202.

Mexico: ELECTRONICA S.A. de C.V., Varsovia No. 36, MEXICO 6, D.F., Tel. 533-11-80.

Netherlands: PHILIPS NEDERLAND B.V., Afd. Elonco, Boschdijk 525, NL 5600 PD EINDHOVEN, Tel. (040) 79 33 33.

New Zealand: PHILIPS Electrical Ind. Ltd., Elcoma Division, 2 Wagener Place, St. Lukes, AUCKLAND, Tel. 867 119.

Norway: NORSK A/S PHILIPS, Electronica Dept., Vitaminveien 11, Grefsen, OSLO 4, Tel. (02) 15 05 90.

Peru: CADESA, Rocca de Vergallo 247, LIMA 17, Tel. 62 85 99.

Philippines: ELDAC, Philips Industrial Dev. Inc., 2246 Pasong Tamo, MAKATI-RIZAL, Tel. 86-89-51 to 59.

Portugal: PHILIPS PORTUGUESA S.A.R.L., Av. Eng. Duharte Pacheco 6, LISBOA 1, Tel. 68 31 21.

Singapore: PHILIPS SINGAPORE PTE LTD., Elcoma Div., P.O.B. 340, Toa Payoh CPO, Lorong 1, Toa Payoh, SINGAPORE 12, Tel. 53 88 11.

South Africa: EDAC (Pty.) Ltd., South Park Lane, New Doornfontein, JOHANNESBURG 2001, Tel. 24/6701.

Spain: COPRESA S.A., Balmes 22, BARCELONA 7, Tel. 301 63 12.

Sweden: A.B. ELCOMA, Lidingövägen 50, S-10250 STOCKHOLM 27, Tel. 08/67 97 80.

Switzerland: PHILIPS A.G., Elcoma Dept., Edenstrasse 20, CH-8027 ZÜRICH, Tel. 01/44 22 11.

Taiwan: PHILIPS TAIWAN LTD., 3rd Fl., San Min Building, 57-1, Chung Shan N. Rd, Section 2, P.O. Box 22978, TAIPEI, Tel. 5513101-5.

Turkey: TÜRK PHILIPS TICARET A.S., EMET Department, Inonu Cad. No. 78-80, ISTANBUL, Tel. 43 59 10.

United Kingdom: MULLARD LTD., Mullard House, Torrington Place, LONDON WC1E 7HD, Tel. 01-580 6633.

United States: (Active devices & Materials) AMPEREX SALES CORP., Providence Pike, SLATERSVILLE, R.I. 02876, Tel. (401) 762-9000.
(Passive devices) MEPCO/ELECTRA INC., Columbia Rd., MORRISTOWN, N.J. 07960, Tel. (201) 539-2000.
(IC Products) SIGNETICS CORPORATION, 811 East Argues Avenue, SUNNYVALE, California 94086, Tel. (408) 739-7700.

Uruguay: LUZILETRON S.A., Rondeau 1567, piso 5, MONTEVIDEO, Tel. 9 43 21.

Venezuela: IND. VENEZOLANAS PHILIPS S.A., Elcoma Dept., A. Ppal de los Ruices, Edif. Centro Colgate, CARACAS, Tel. 36 05 11.