



Package: QFN, 20-pin,  
4.0mm x 4.0mm x 0.9mm

# RFPA5522

WiFi Integrated PA Module  
4.9GHz to 5.925GHz

The RFPA5522 is a three-stage power amplifier (PA) designed for 802.11a/n/ac applications. The integrated input and output 50Ω match greatly reduces the layout area, bill of materials and manufacturability cost in the customer application. The RFPA5522 is manufactured on an advanced InGaP heterojunction bipolar transistor (HBT) process and is capable of achieving linear powers up to 23dBm with an EVM <1.8% while maintaining excellent power added efficiency. The device is provided in a 4.0mm x 4.0mm x 0.9mm laminate package that meets or exceeds the power requirements of IEEE802.11a/n/ac WiFi RF systems.

## Features

- P<sub>OUT</sub> = 23dBm, 5V, 11ac, 80MHz MCS9 @ 1.8% EVM
- P<sub>OUT</sub> = 25dBm, 5V, 11n, 20/40 MHz, MCS7 @ 3% EVM
- Typical Gain = 33dB
- 3.3v Functionality
- High PAE
- Integrated Regulator
- Input and Output Matched to 50Ω
- Integrated Power Detector, Harmonic filter, and notch filter

## Applications

- Customer Premise Equipment (CPE)
- Wireless Access Points, Gateways
- Routers
- Set-Top Box Applications
- Picocell/Femtocell

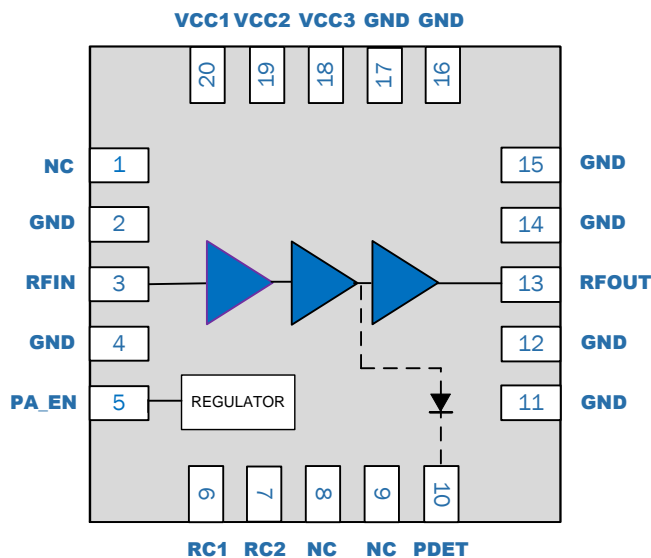

Functional Block Diagram

## Ordering Information

RFPA5522SB	Standard 5-piece Sample Bag
RFPA5522SQ	Standard 25-piece Sample Bag
RFPA5522SR	Standard 100-piece Reel
RFPA5522TR13	Standard 2500-piece Reel
RFPA5522PCK-410	Fully Assembled Evaluation Board w/5-piece bag

# RFPA5522

## Absolute Maximum Ratings

Parameter	Rating	Unit
DC Supply Voltage	-0.5 to +6	V <sub>DC</sub>
DC Supply Current	1000	mA
Operating Temperature Range	-40 to +85	°C
Storage Temperature	-40 to +150	°C
Maximum TX Input Power into 50Ω for 11a/n/ac (No Damage). *R1=0Ω	+10	dBm
Maximum TX Input Power 10:1 VSWR for 11a/n/ac (No Damage). *R1=15Ω	+15	dBm
Junction Temperature	+160	C
Moisture Sensitivity Level (260°C JEDEC J-STD-020)	MSL2	

\*Note: For R1 placement please refer to the applications schematic



Caution! ESD sensitive device.



RFMD Green: RoHS status based on EU Directive 2011/65/EU (at time of this document revision), halogen free per IEC 61249-2-21, < 1000ppm each of antimony trioxide in polymeric materials and red phosphorus as a flame retardant, and <2% antimony in solder.

Exceeding any one or a combination of the Absolute Maximum Rating conditions may cause permanent damage to the device. Extended application of Absolute Maximum Rating conditions to the device may reduce device reliability. Specified typical performance or functional operation of the device under Absolute Maximum Rating conditions is not implied. This is an InGaP PA designed for high duty cycle applications with T<sub>j</sub>>100°C

## Nominal Operating Parameters

Parameter	Specification			Unit	Condition
	Min	Typ	Max		
<b>Compliance</b>					<b>802.11a/n/ac</b>
Operating Frequency	5.180		5.925	GHz	
Extended Operating Frequency	4.900		5.180	GHz	
Power Supply V <sub>CC</sub>	3.0	5.00	5.25	V	
PA Enable - High	1.7	3.0	3.3	V	
PA Enable - Low	0		0.5	V	
<b>5V Transmit Performance</b>					<b>T= +25°C, V<sub>CC</sub>=5.0V, V<sub>PAEN</sub> = 3.0V, Unless otherwise noted</b>
11ac 80MHz Output Power	22	23		dBm	MCS9 256QAM
11ac 80MHz EVM		1.5	1.8	%	
		-36.5	-35	dB	
11ac 160MHz Output Power		22		dBm	MCS9 256QAM
11ac 160MHz EVM			1.8	%	
			-35	dB	
11n 20/40MHz Output Power	23.5	25		dBm	MCS7 64QAM
11n 40MHz EVM			3	%	
			-30.5	dB	
11a Output Power	23.5	25		dBm	54Mbps 64QAM
11a DEVM		3	4	%	
		-30.5	-28	dB	
Gain	31	33		dB	
Gain Variation	-2		2.5	dB	Over operating temp; over 100MHz BW
Margin to Spectral Mask		5		dBm	P <sub>OUT</sub> =23dBm; MCS0 160MHz
		5		dBm	P <sub>OUT</sub> =25dBm; MCS0 80MHz
		5		dBm	P <sub>OUT</sub> =26dBm; MCS0 40MHz;
		5		dBm	P <sub>OUT</sub> =27dBm; MCS0 20MHz;
Operating Current		285	330	mA	P <sub>OUT</sub> =23dBm
		385	430		P <sub>OUT</sub> =27dBm

# RFPA5522

RFMD + TriQuint = Qorvo

Parameter	Specification			Unit	Condition
	Min	Typ	Max		
<b>5V Transmit Performance (continued)</b>					<b>T= +25°C, V<sub>CC</sub>=5.0V, V<sub>PAEN</sub> = 3.0V, Unless otherwise noted</b>
Quiescent Current		150		mA	
PA Enable Current		4	20	uA	PA_EN High
Leakage Current		1	5	uA	RF OFF; V <sub>PAEN</sub> = 0V
Second Harmonic		-45	-40	dBm/MHz	P <sub>OUT</sub> = 27dBm; OFDM 6Mbps
Third Harmonic		-50	-45	dBm/MHz	
OOB Gain		-5		dB	3.3 – 3.8GHz
		7		dB	7.0 GHz
Input Return Loss		12		dB	
Output Return Loss		12		dB	
Power Detector Range		0.25		V	P <sub>OUT</sub> = 0dBm
		0.65			P <sub>OUT</sub> = 23dBm
		0.88		V	P <sub>OUT</sub> = 27dBm
<b>3.3V Transmit Performance</b>					<b>T= +25°C, V<sub>CC</sub>=3.3V, V<sub>PAEN</sub> = 3.0V, Unless otherwise noted</b>
11ac 80MHz Output Power	18	19		dBm	MCS9 256QAM
11ac 80MHz EVM		1.5	1.8	%	
		-36.5	-35	dB	
11n 20/40MHz Output Power	19	20		dBm	MCS7 64QAM
11n 40MHz EVM			3	%	
			-30	dB	
11ac 160MHz Output Power		18		dBm	MCS9 256QAM
11ac 160MHz EVM		1.5	1.8	%	
		-36.5	-35	dB	
Gain	31	33		dB	
Gain Variation	-2.5		+3.0	dB	Over temp; over 100MHz BW
Margin to Spectral Mask		5		dBm	P <sub>OUT</sub> =21dBm; MCS0 80MHz
		5		dBm	P <sub>OUT</sub> =19dBm; MCS0 160MHz
		5		dBm	P <sub>OUT</sub> =22dBm; MCS0 40MHz
		5		dBm	P <sub>OUT</sub> =23dBm; MCS0 20MHz
Operating Current		210	235	mA	P <sub>OUT</sub> =19dBm
		275	300		P <sub>OUT</sub> =23dBm
Quiescent Current		150		mA	
PA Enable Current		375	500	uA	PA_EN High
Leakage Current		1	5	uA	RF OFF; V <sub>PAEN</sub> = 0V
Second Harmonic		-50	-45	dBm/MHz	P <sub>OUT</sub> = 23dBm; OFDM 6Mbps
Third Harmonic		-50	-45	dBm/MHz	
Input Return Loss		12		dB	
Output Return Loss		12		dB	
Power Detector Range		0.25		V	P <sub>OUT</sub> = 0dBm
		0.5		V	P <sub>OUT</sub> = 18dBm
		0.7		V	P <sub>OUT</sub> = 23dBm

## RFPA5522

Parameter	Specification			Unit	Condition
	Min	Typ	Max		
<b>General Specifications</b>					
Stability	VSWR 4:1; Output Power 0 to 27dBm				CW signal. No spurious above -41.25dBm/MHz for non-harmonic related signals.
Output P1dB		33		dBm	CW signal; 5V
		29		dBm	CW signal; 3.3V
Ramp ON/OFF time		200		nS	10-90% / 90-10% of gain
<b>General Specifications</b>					
Thermal Resistance*		32		°C/W	At Pout=27dBm
ESD HBM	500			V	EIA/JESD22-114A; All pins
ESD CDM	500			V	JESD22-C101C; All pins

# RFPA5522

## Timing Diagram

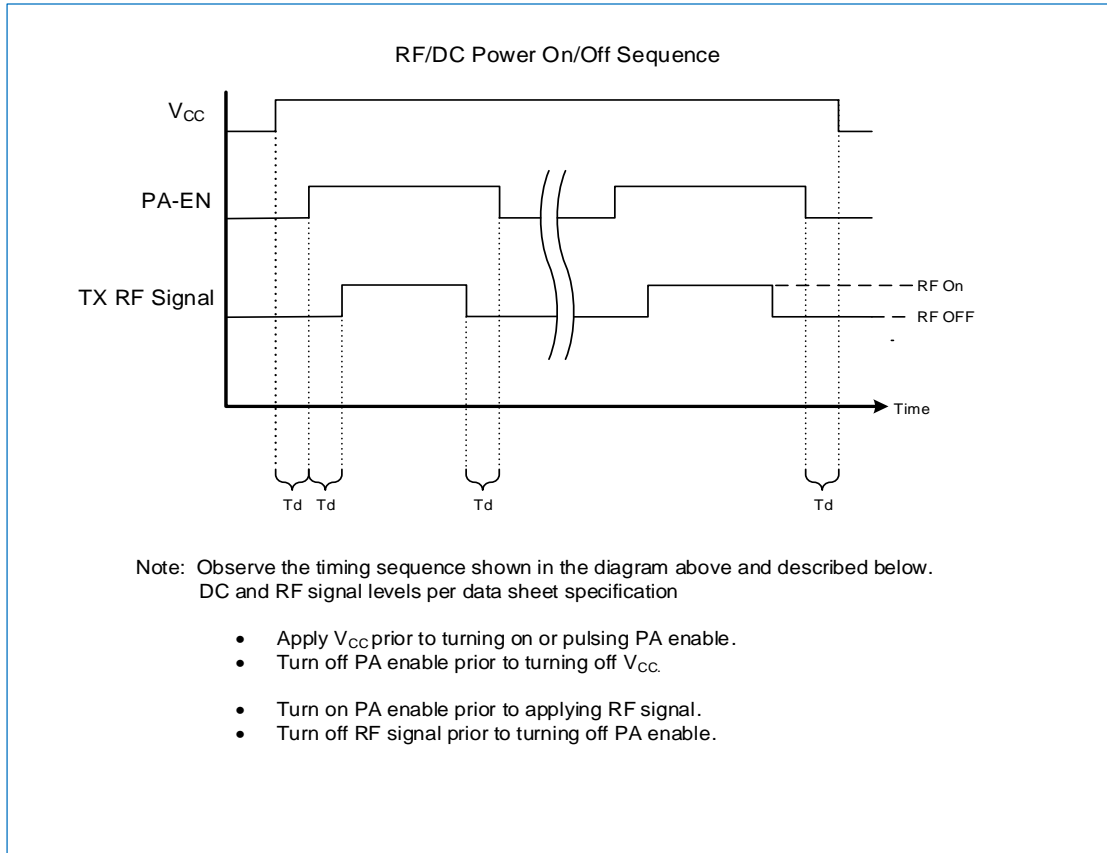

RFPA5522

RFPA5522 5V Applications Schematic

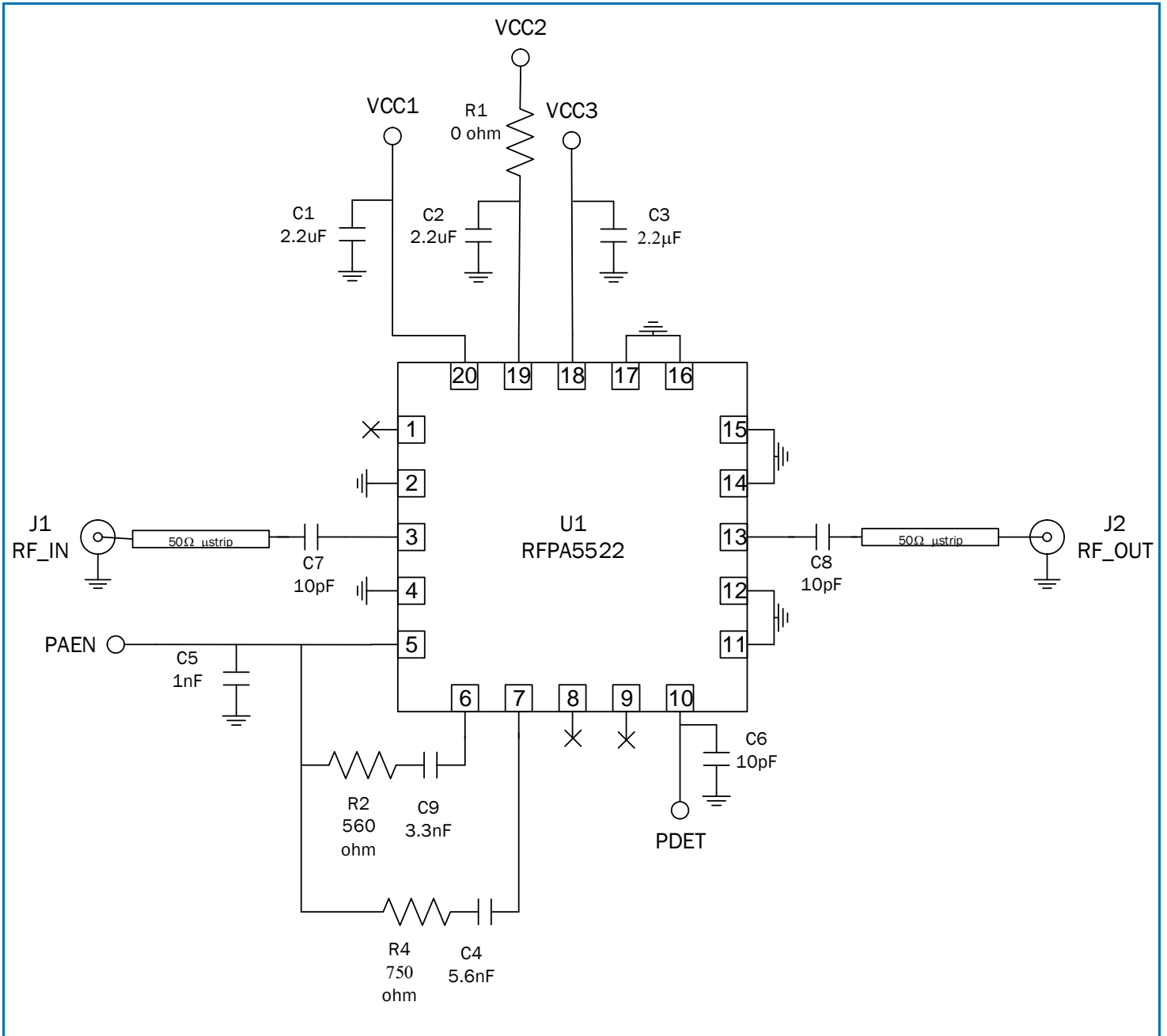

\*0402 component size required

# RFPA5522

## RFPA5522 3.3V Applications Schematic

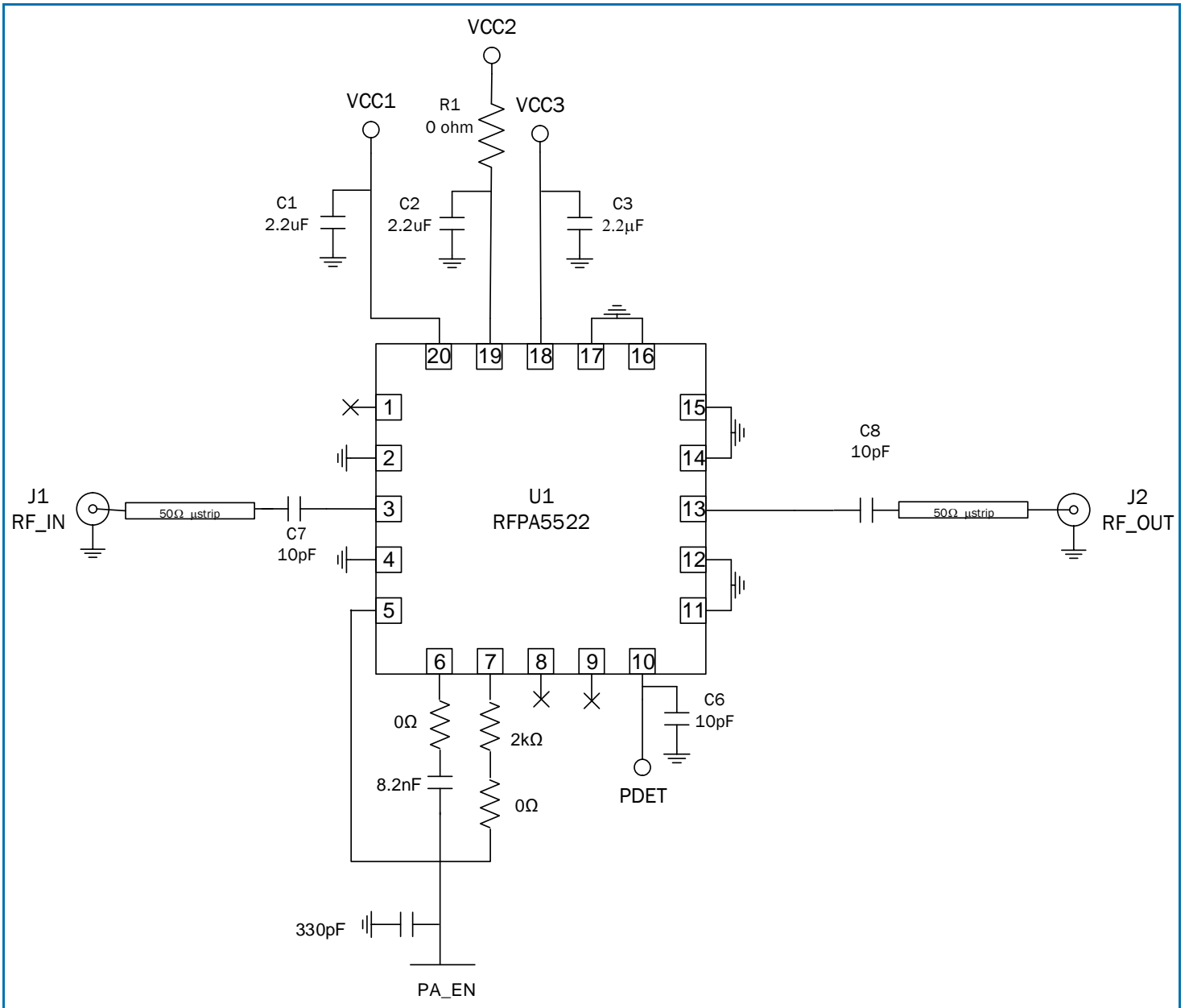

\*0402 component size required

RFPA5522

Pin Out

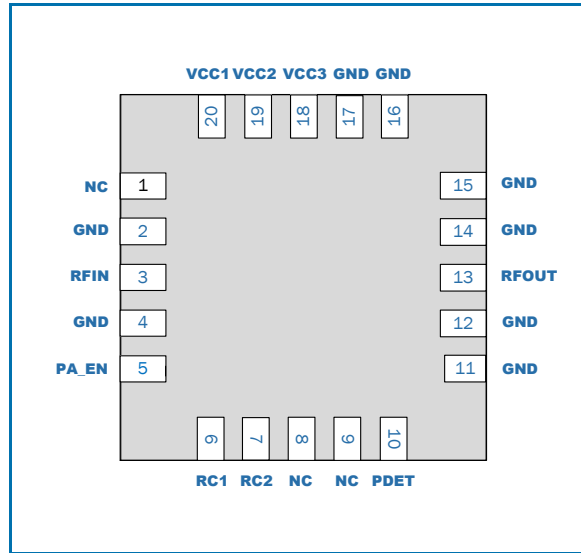

Package Drawing

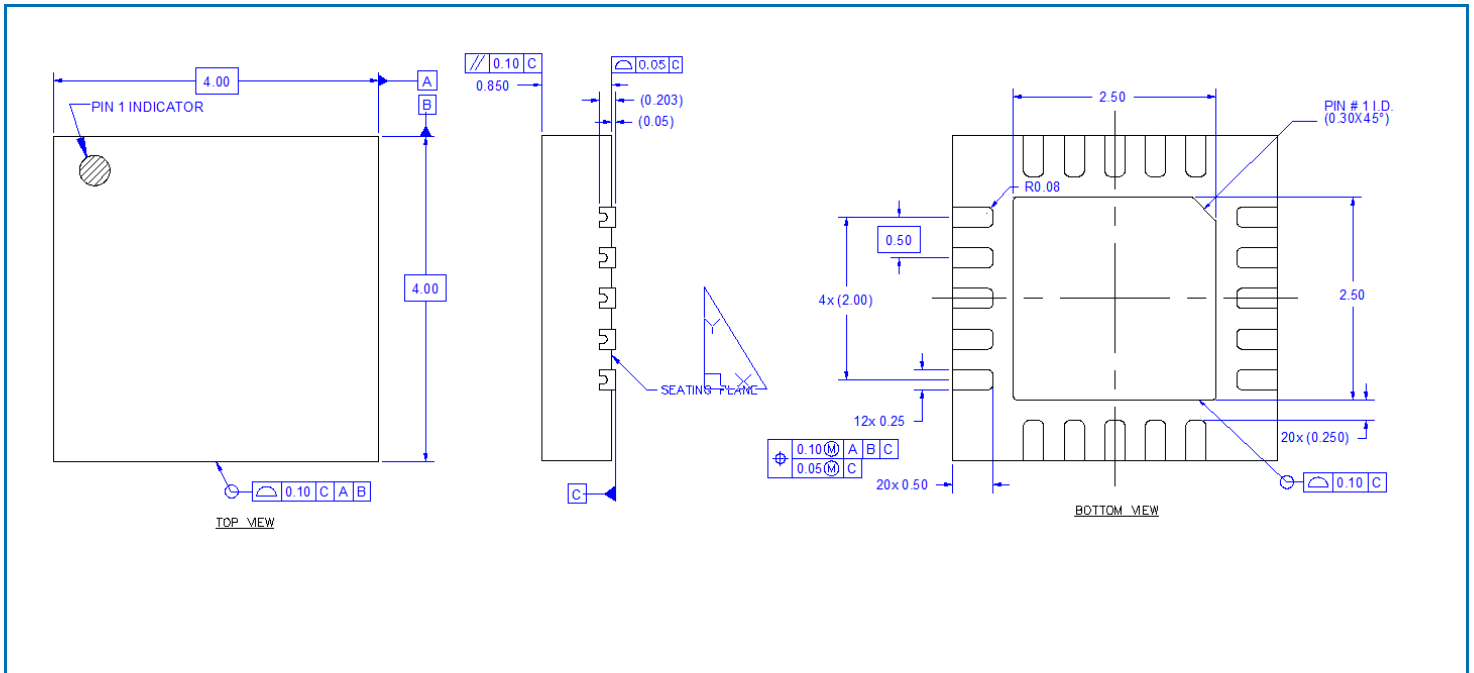



RFPA5522

PCB Patterns

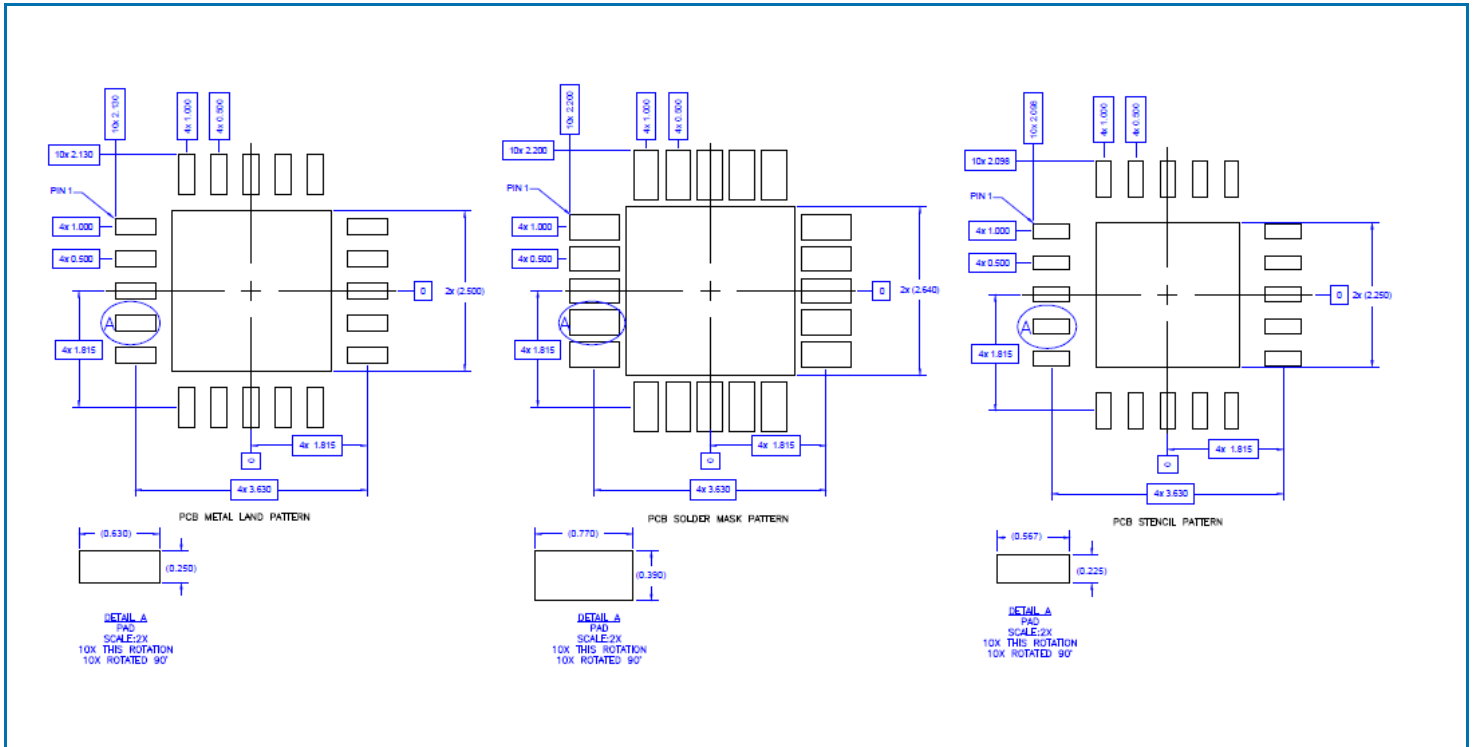

# RFPA5522

## Pin Names and Descriptions

Pin	Name	Description
1	NC	Not connected internally. It may be left floating or connected to ground.
2	GND	Ground connection. This pin is not connected internally and can be left floating or connected to ground.
3	RFIN	RF input, internally matched to 50Ω and DC shorted. External DC blocking capacitor required.
4	GND	Ground connection. This pin is not connected internally and can be left floating or connected to ground.
5	PA_EN	PA Enable pin. Apply <math><0.4V_{DC}</math>. Apply 1.5V <sub>DC</sub> to V <sub>CC</sub> to enable PA.
6	RC1	Tuning RC pin 1. See EVB schematic for details.
7	RC2	Tuning RC pin 2. See EVB schematic for details.
8	NC	Not connected internally. It may be left floating or connected to ground.
9	NC	Not connected internally. It may be left floating or connected to ground.
10	PDET	Power detector. Provides an output voltage proportional to the RF output power level.
11	GND	Ground connection. This pin is not connected internally and can be left floating or connected to ground.
12	GND	Ground connection. This pin is not connected internally and can be left floating or connected to ground.
13	RFOUT	RF output, internally matched to 50Ω and DC shorted. External DC blocking capacitor required.
14	GND	Ground connection. This pin is not connected internally and can be left floating or connected to ground.
15	GND	Ground connection. This pin is not connected internally and can be left floating or connected to ground.
16	GND	Ground connection. This pin is not connected internally and can be left floating or connected to ground.
17	GND	Ground connection. This pin is not connected internally and can be left floating or connected to ground.
18	VCC3	Third stage supply voltage
19	VCC2	Second stage supply voltage.
20	VCC1	First stage supply voltage.
Pkg Base	GND	Ground connection. The back side of the package should be connected to the ground plan though as short of a connection as possible. PCB vias under the device are recommended.

# Mouser Electronics

Authorized Distributor

Click to View Pricing, Inventory, Delivery & Lifecycle Information:

Qorvo:

[RFPA5522TR13](#) [RFPA5522SR](#)