



3-TERMINALS 1A POSITIVE VOLTAGE REGULATOR

DESCRIPTION

The AMS **78MXX** family is monolithic fixed voltage regulator integrated circuit. They are suitable for applications that required supply current up to 1 A.

FEATURE

- * Output Current Up To 1 A
- * Fixed Output Voltage Of 5V, 6V, 8V, 9V, 12V, 15V and 18V Available
- * Thermal Overload Shutdown Protection
- * Short Circuit Current Limiting
- * Output Transistor SOA Protection

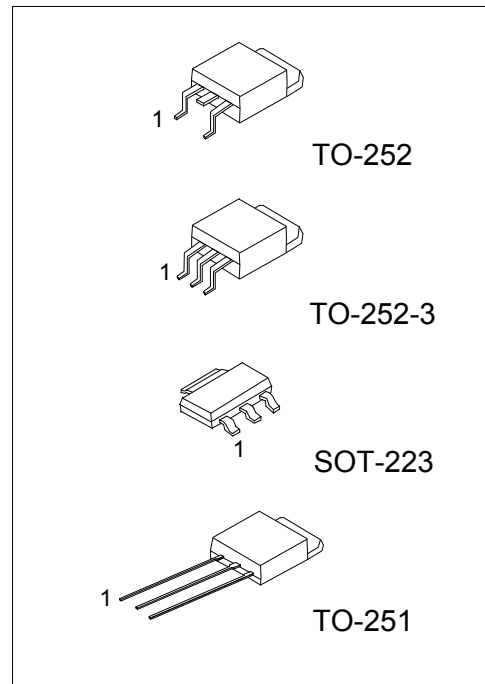

ORDERING INFORMATION

Ordering Number		Package	Pin Assignment			Packing
Lead Free	Halogen Free		1	2	3	
78MxxL-AA3-R	78MxxG-AA3-R	SOT-223	I	G	O	Tape Reel
78MxxL-TM3-T	78MxxG-TM3-T	TO-251	I	G	O	Tube
78MxxL-TN3-R	78MxxG-TN3-R	TO-252	I	G	O	Tape Reel
78MxxL-TNA-R	78MxxG-TNA-R	TO-252-3	I	G	O	Tape Reel

Note: 1. xx: Output Voltage, refer to Marking Information
 2. Pin Code: I: Input G: GND O: Output

<p>78MxxL-AA3-R</p> <p>(1)Packing Type (2)Package Type (3)Lead Free (4)Output Voltage Code</p>	<p>(1) R: Tape Reel, T: Tube (2) AA3: SOT-223, TM3: TO-251, TN3: TO-252, TNA: TO-252-3 (3) G: Halogen Free, L: Lead Free (4) xx: refer to Marking Information</p>
---	--

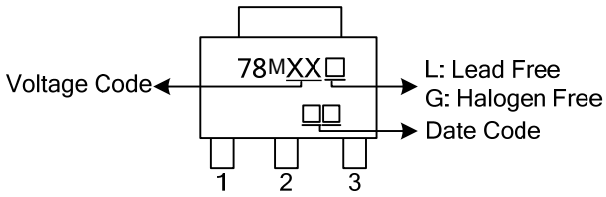
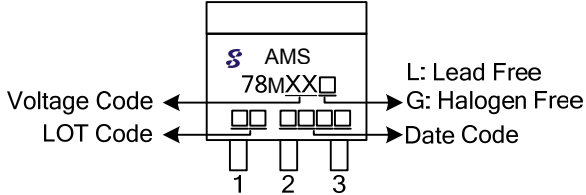

MARKING INFORMATION

PACKAGE	VOLTAGE CODE	MARKING
SOT-223	05: 5V 06: 6V 08: 8V 09: 9V	
TO-251 TO-252 TO-252-3	12: 12V 15: 15V 18: 18V	



■ BLOCK DIAGRAM

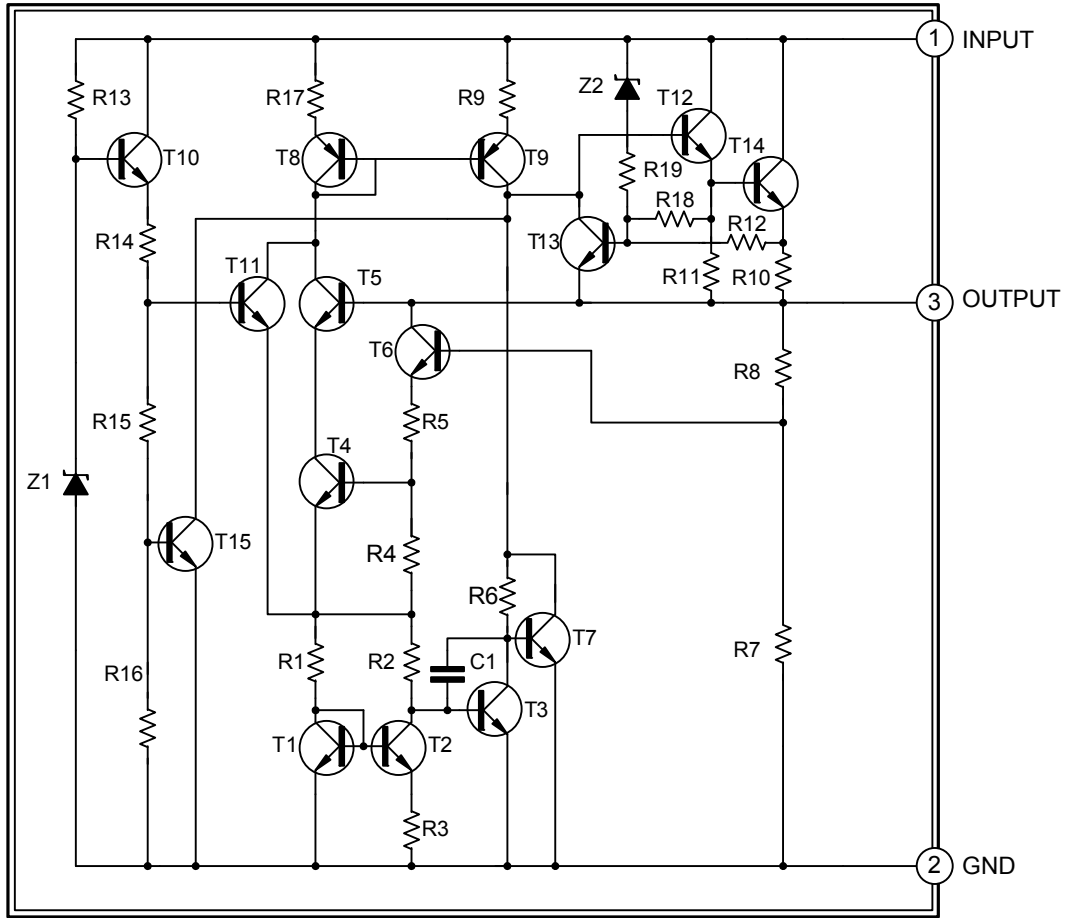

■ TYPICAL APPLICATION CIRCUIT

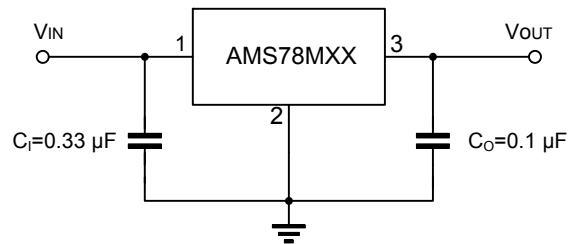

Note: Bypass capacitors are recommended for optimum stability and transient response and should be located as close as possible to the regulators.



■ ABSOLUTE MAXIMUM RATINGS ($T_J=25^\circ\text{C}$, unless otherwise specified)

PARAMETER	SYMBOL	RATINGS	UNIT
Input Voltage	V_{IN}	35	V
Output Current	I_{OUT}	1	A
Power Dissipation ($T_C=25^\circ\text{C}$)	SOT-223	8.5	W
	TO-251 / TO-252	10	
Operating Junction Temperature	T_J	-20 ~ +150	$^\circ\text{C}$
Storage Temperature	T_{STG}	-65 ~ +150	$^\circ\text{C}$

Notes: Absolute maximum ratings are those values beyond which the device could be permanently damaged.
Absolute maximum ratings are stress ratings only and functional device operation is not implied.

■ THERMAL DATA

PARAMETER	SYMBOL	RATINGS	UNIT
Junction to Case	SOT-223	15	$^\circ\text{C/W}$
	TO-251 / TO-252	12.5	

■ ELECTRICAL CHARACTERISTICS

($T_J=25^\circ\text{C}$, $C_I=0.33\mu\text{F}$, $C_O=0.1\mu\text{F}$, $P_D\leq 7\text{W}$, unless otherwise specified)

For 78M05 ($V_{IN}=10\text{V}$, $I_{OUT}=1\text{A}$)

PARAMETER	SYMBOL	TEST CONDITIONS	MIN	TYP	MAX	UNIT
Output Voltage	V_{OUT}	$I_{OUT}=5\text{mA}\sim 1\text{A}$	4.8	5	5.2	V
		$V_{IN}=7.5\sim 20\text{V}$, $I_{OUT}=5\text{mA}\sim 1\text{A}$	4.75		5.25	V
Load Regulation	ΔV_{OUT}	$I_{OUT}=5\text{mA}\sim 1\text{A}$			100	mV
		$I_{OUT}=5\text{mA}\sim 200\text{mA}$			50	mV
Line Regulation	ΔV_{OUT}	$V_{IN}=7\text{V}\sim 25\text{V}$			100	mV
		$V_{IN}=7.5\sim 20\text{V}$, $I_{OUT}=1\text{A}$			50	mV
Quiescent Current	I_Q	$I_{OUT}=1\text{A}$			8	mA
Quiescent Current Change	ΔI_Q	$V_{UT}=7.5\sim 20\text{V}$			1	mA
		$I_{OUT}=5\text{mA}\sim 1\text{A}$			1	mA
Output Noise Voltage	eN	$10\text{Hz}\leq f\leq 100\text{kHz}$		40		μV
Temperature coefficient of V_{OUT}	$\Delta V_{OUT}/\Delta T$	$I_{OUT}=5\text{mA}$		-0.6		$\text{mV}/^\circ\text{C}$
Ripple Rejection	RR	$V_{IN}=8\sim 18\text{V}$, $f=120\text{Hz}$	62	80		dB
Peak Output Current	I_{PEAK}			1.8		A
Short-Circuit Current	I_{SC}	$V_{IN}=35\text{V}$		250		mA
Dropout Voltage	V_D			2		V

For 78M06 ($V_{IN}=11\text{V}$, $I_{OUT}=1\text{A}$)

PARAMETER	SYMBOL	TEST CONDITIONS	MIN	TYP	MAX	UNIT
Output Voltage	V_{OUT}	$I_{OUT}=5\text{mA}\sim 1\text{A}$	5.76	6	6.24	V
		$V_{IN}=8.5\sim 21\text{V}$, $I_{OUT}=5\text{mA}\sim 1\text{A}$	5.7		6.3	V
Load Regulation	ΔV_{OUT}	$I_{OUT}=5\text{mA}\sim 1\text{A}$			60	mV
		$I_{OUT}=5\text{mA}\sim 200\text{mA}$			30	mV
Line Regulation	ΔV_{OUT}	$V_{IN}=8\sim 25\text{V}$			60	mV
		$V_{IN}=8.5\sim 21\text{V}$, $I_{OUT}=1\text{A}$			60	mV
Quiescent Current	I_Q	$I_{OUT}=1\text{A}$			8	mA
Quiescent Current Change	ΔI_Q	$V_{IN}=8.5\sim 21\text{V}$			1	mA
		$I_{OUT}=5\text{mA}\sim 1\text{A}$			1	mA
Output Noise Voltage	eN	$10\text{Hz}\leq f\leq 100\text{kHz}$		45		μV
Temperature coefficient of V_{OUT}	$\Delta V_{OUT}/\Delta T$	$I_{OUT}=5\text{mA}$		-0.7		$\text{mV}/^\circ\text{C}$
Ripple Rejection	RR	$V_{IN}=9\sim 19\text{V}$, $f=120\text{Hz}$	59	75		dB
Peak Output Current	I_{PEAK}			1.8		A
Short-Circuit Current	I_{SC}	$V_{IN}=35\text{V}$		250		mA
Dropout Voltage	V_D			2		V



■ ELECTRICAL CHARACTERISTICS (Cont.)

For 78M08 ($V_{IN}=14V$, $I_{OUT}=1A$)

PARAMETER	SYMBOL	TEST CONDITIONS	MIN	TYP	MAX	UNIT
Output Voltage	V_{OUT}	$I_{OUT}=5mA\sim 1A$	7.68	8	8.32	V
		$V_{IN}=10.5\sim 23V$, $I_{OUT}=5mA\sim 1A$	7.6		8.4	V
Load Regulation	ΔV_{OUT}	$I_{OUT}=5mA\sim 1A$			80	mV
		$I_{OUT}=5mA\sim 200mA$			40	mV
Line Regulation	ΔV_{OUT}	$V_{IN}=10.5\sim 25V$			80	mV
		$V_{IN}=10.5\sim 23V$, $I_{OUT}=1A$			80	mV
Quiescent Current	I_Q	$I_{OUT}=1A$			8	mA
Quiescent Current Change	ΔI_Q	$V_{IN}=10.5\sim 23V$			1	mA
		$I_{OUT}=5mA\sim 1A$			0.5	mA
Output Noise Voltage	eN	$10Hz \leq f \leq 100kHz$		58		μV
Temperature coefficient of V_{OUT}	$\Delta V_{OUT}/\Delta T$	$I_{OUT}=5mA$		-0.9		$mV/^\circ C$
Ripple Rejection	RR	$V_{IN}=11.5\sim 21.5V$, $f=120Hz$	56	72		dB
Peak Output Current	I_{PEAK}			1.8		A
Short-Circuit Current	I_{SC}	$V_{IN}=35V$		250		mA
Dropout Voltage	V_D			2		V

For 78M09 ($V_{IN}=15V$, $I_{OUT}=1A$)

PARAMETER	SYMBOL	TEST CONDITIONS	MIN	TYP	MAX	UNIT
Output Voltage	V_{OUT}	$I_{OUT}=5mA\sim 1A$	8.64	9	9.36	V
		$V_{IN}=11.5\sim 24V$, $I_{OUT}=5mA\sim 1A$	8.55		9.45	V
Load Regulation	ΔV_{OUT}	$I_{OUT}=5mA\sim 1A$			90	mV
		$I_{OUT}=5mA\sim 200mA$			45	mV
Line Regulation	ΔV_{OUT}	$V_{IN}=11.5\sim 25V$			90	mV
		$V_{IN}=11.5\sim 24V$, $I_{OUT}=1A$			90	mV
Quiescent Current	I_Q	$I_{OUT}=1A$			8	mA
Quiescent Current Change	ΔI_Q	$V_{IN}=11.5\sim 24V$			1	mA
		$I_{OUT}=5mA\sim 1A$			0.5	mA
Output Noise Voltage	eN	$10Hz \leq f \leq 100kHz$		58		μV
Temperature coefficient of V_{OUT}	$\Delta V_{OUT}/\Delta T$	$I_{OUT}=5mA$		-1.1		$mV/^\circ C$
Ripple Rejection	RR	$V_{IN}=12.5\sim 22.5V$, $f=120Hz$	56	72		dB
Peak Output Current	I_{PEAK}			1.8		A
Short-Circuit Current	I_{SC}	$V_{IN}=35V$		250		mA
Dropout Voltage	V_D			2		V

For 78M12 ($V_{IN}=19V$, $I_{OUT}=1A$)

PARAMETER	SYMBOL	TEST CONDITIONS	MIN	TYP	MAX	UNIT
Output Voltage	V_{OUT}	$I_{OUT}=5mA\sim 1A$	11.52	12	12.48	V
		$V_{IN}=14.5\sim 27V$, $I_{OUT}=5mA\sim 1A$	11.4		12.6	V
Load Regulation	ΔV_{OUT}	$I_{OUT}=5mA\sim 1A$			120	mV
		$I_{OUT}=5mA\sim 200mA$			60	mV
Line Regulation	ΔV_{OUT}	$V_{IN}=14.5\sim 30V$			120	mV
		$V_{IN}=14.6\sim 27V$, $I_{OUT}=1A$			120	mV
Quiescent Current	I_Q	$I_{OUT}=1A$			8	mA
Quiescent Current Change	ΔI_Q	$V_{IN}=14.5\sim 30V$			1	mA
		$I_{OUT}=5mA\sim 1A$			0.5	mA
Output Noise Voltage	eN	$10Hz \leq f \leq 100kHz$		75		μV
Temperature coefficient of V_{OUT}	$\Delta V_{OUT}/\Delta T$	$I_{OUT}=5mA$		-1.5		$mV/^\circ C$
Ripple Rejection	RR	$V_{IN}=15\sim 25V$, $f=120Hz$	55	72		dB
Peak Output Current	I_{PEAK}			1.8		A
Short-Circuit Current	I_{SC}	$V_{IN}=35V$		250		mA
Dropout Voltage	V_D			2		V



■ ELECTRICAL CHARACTERISTICS(Cont.)

For 78M15 ($V_{IN}=23V$, $I_{OUT}=1A$, $C_I=0.33\mu F$, $C_O=0.1\mu F$),

PARAMETER	SYMBOL	TEST CONDITIONS	MIN	TYP	MAX	UNIT
Output Voltage	V_{OUT}	$I_{OUT}=5mA\sim 1A$	14.4	15	15.6	V
		$V_{IN}=17.5\sim 30V$, $I_{OUT}=5mA\sim 1A$	14.25		15.75	V
Load Regulation	ΔV_{OUT}	$I_{OUT}=5mA\sim 1A$			150	mV
		$I_{OUT}=5mA\sim 200mA$			75	mV
Line Regulation	ΔV_{OUT}	$V_{IN}=18.5\sim 30V$			150	mV
		$V_{IN}=17.5\sim 30V$, $I_{OUT}=1A$			150	mV
Quiescent Current	I_Q	$I_{OUT}=1A$			8	mA
Quiescent Current Change	ΔI_Q	$V_{IN}=17.5\sim 30V$			1	mA
		$I_{OUT}=5mA\sim 1A$			0.5	mA
Output Noise Voltage	eN	$10Hz \leq f \leq 100kHz$		90		μV
Temperature coefficient of V_{OUT}	$\Delta V_{OUT}/\Delta T$	$I_{OUT}=5mA$		-1.8		$mV/^\circ C$
Ripple Rejection	RR	$V_{IN}=18.5\sim 28.5V$, $f=120Hz$	54	70		dB
Peak Output Current	I_{PEAK}			1.8		A
Short-Circuit Current	I_{SC}	$V_{IN}=35V$		250		mA
Dropout Voltage	V_D			2		V

For 78M18 ($V_{IN}=27V$, $I_{OUT}=1A$)

PARAMETER	SYMBOL	TEST CONDITIONS	MIN	TYP	MAX	UNIT
Output Voltage	V_{OUT}	$I_{OUT}=5mA\sim 1A$	17.28	18	18.72	V
		$V_{IN}=21\sim 33V$, $I_{OUT}=5mA\sim 1A$	17.1		18.9	V
Load Regulation	ΔV_{OUT}	$I_{OUT}=5mA\sim 1A$			180	mV
		$I_{OUT}=5mA\sim 200mA$			90	mV
Line Regulation	ΔV_{OUT}	$V_{IN}=21\sim 33V$			180	mV
		$V_{IN}=21\sim 33V$, $I_{OUT}=1A$			180	mV
Quiescent Current	I_Q	$I_{OUT}=1A$			8	mA
Quiescent Current Change	ΔI_Q	$V_{IN}=21.5\sim 33V$			1	mA
		$I_{OUT}=5mA\sim 1A$			0.5	mA
Output Noise Voltage	eN	$10Hz \leq f \leq 100kHz$		110		μV
Temperature coefficient of V_{OUT}	$\Delta V_{OUT}/\Delta T$	$I_{OUT}=5mA$		-2.2		$mV/^\circ C$
Ripple Rejection	RR	$V_{IN}=22\sim 32V$, $f=120Hz$	53	69		dB
Peak Output Current	I_{PEAK}			1.8		A
Short-Circuit Current	I_{SC}	$V_{IN}=35V$		250		mA
Dropout Voltage	V_D			2		V



■ TYPICAL CHARACTERISTICS

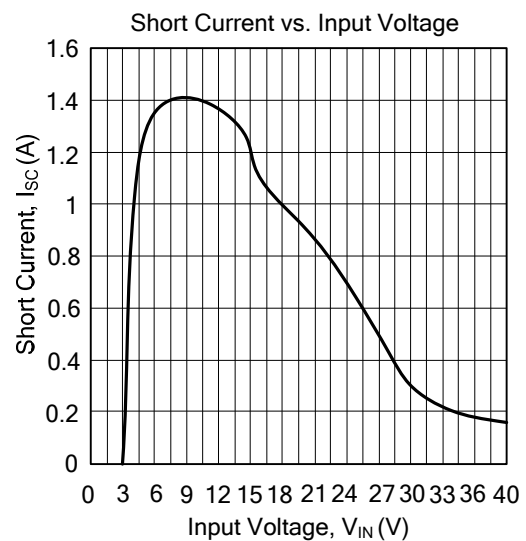
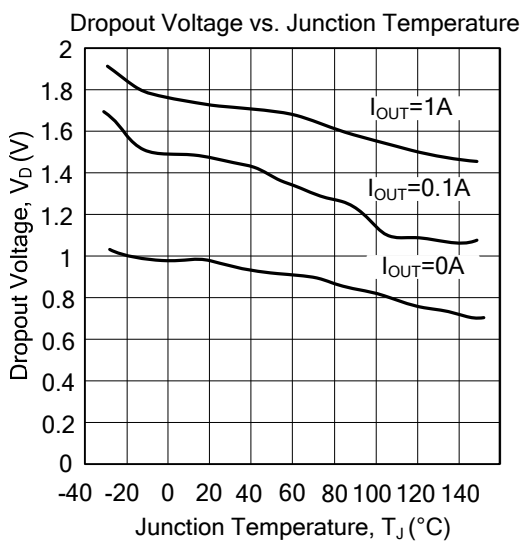
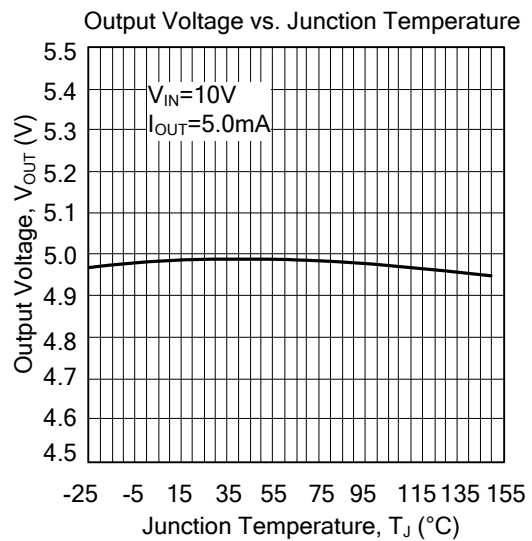
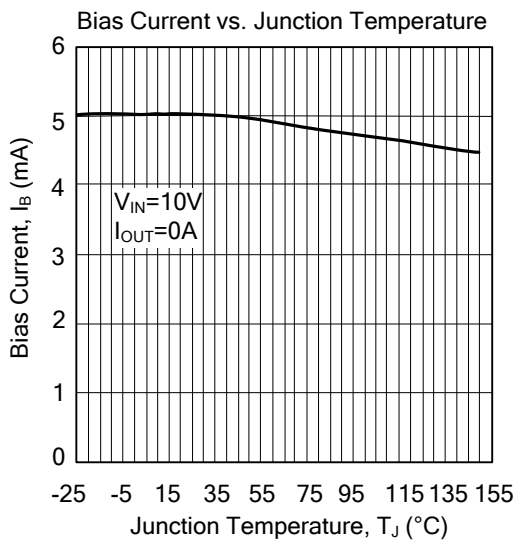
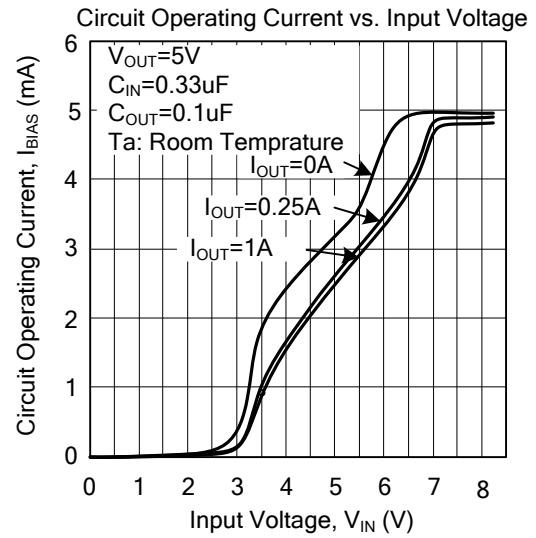
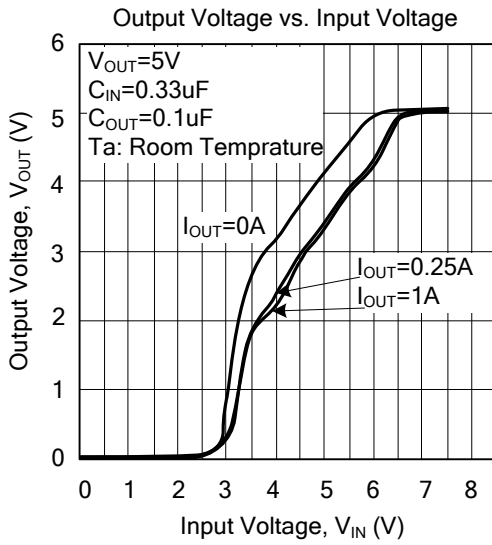



■ TYPICAL CHARACTERISTICS (Cont.)

